

FAHRZEUGTEILE & ZUBEHÖR
SPARE PARTS & ACCESSORIES



MGA

1500 – 1600 – 1622 – Twin Cam

► **Bitte bei allen Bestellungen Kunden- und Artikel-Nummer angeben !**

PS: Die Preise für unsere Produkte finden Sie in der separaten Preisliste ganz leicht mit Hilfe der Artikelnummer. Bestellen können Sie per Telefon oder Fax, per Post oder ganz bequem per eMail.

Hilfreiche Hinweise für eine schnelle Bearbeitung Ihrer Bestellung finden Sie ebenfalls in der Preisliste.

► **Note: when ordering please ensure article and client number !**

PS : A few advices for your order: The pricing for our products are listed in the separate price list. Here you can get the pricing with the reference number easily. You can order per Post, Telephone, Telefax or very comfortable via E-Mail. Shipment will be made on the cheapest way without extra charge for packing. You will be charged only the delivery costs. Find more details to shipment and handling in the separate price list.

Hinweise / Notes



Fahrtrichtung /
Sense of direction

- Linke oder rechte (Fahrzeug) Seite
= in Fahrtrichtung gesehen

Left or right side (of the car)
= in sense of direction

- AT-Teile = Austauschteile
Exch.. = parts for exchange

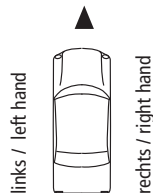

- Anzahl/Qty. = benötigte Anzahl / quantity required
A/R = Anzahl auf Anfrage / quantity at request
1/1 = Bsp.: 1 Artikel pro Seite / 1 piece per side

- ACHTUNG: Elektroteile und Literatur sind vom Umtausch ausgeschlossen!
ATTENTION: electrical parts and literature are not returnable!

MGA

		Seite / Page
Motorteile / Zylinderkopf	Engine / Cylinder Head	4
Ansaugbrücke / Luftfilter / Edelstahl Auspuffanlagen	Manifold / Air Filter / Stainless Exhaust Systems	19
Vergaser	Carburettor	22
Rennsport & Motortuning	Race & Motor Tuning	25
Kühlanlage	Cooling System	30
Zusatzkühlung / Heizung	Electrical Fan / Heater	32
Benzinpumpe / Tankanlage	Petrol Pump / Tank	34
Kupplung	Clutch	36
Getriebe	Gearbox	38
Austausch-, Altteile	Exchange parts	41
Kardanwelle / Blattfeder	Drive Shaft / Plate Spring	42
Hinterachse / Differential	Rear Axle / Differential	44
Vorderachse	Front Suspension	46
Lenkung	Steering	50
Lenkräder	Steering Wheels	52
Felgen / Accessoires	Rims / Accessories	54
Bremsanlage	Brake System	56
Gummistopfen / Kabeltüllen	Rubber Plugs / Cable Spouts	64
Zündung / Verteiler	Ignition / Distributor	64
Kabelbaum / Sicherungen / Relais	Wiring Loom / Fuses / Relais	66
Schalter Instrumente	Switches Instruments	68
Zusatzinstrumente	Instruments	70
Anlasser / Lichtmaschine	Starter Motor / Generator	71
Beleuchtung	Lights	72
Scheibenwaschanlage	Wiper & Washer System	74
Scheiben- / Gummiteile	Screen- / Rubber parts	75
Tür-Mechanismus / Scheiben	Door- Handling / Screens	76
Karosserieteile	Body Panels	78
Karosserieteile / Rahmen	Body Panels / Chassis	82
Verdeck / Verdeckabdeckung	Hood / Tonneau Cover	84
Innenausstattung	Upholstery	86
Chromteile / Stoßstange / Gummiteile	Chrome Parts / Bumper / Rubber Parts	92
Accessoires /	Accessories /	98
Team Bastuck Collection	Team Bastuck Collection	
Literatur	Literature	100
Werkzeug & Hilfsmittel	Tools & Externals	102
Pflege- und Schmiermittel	Care Products / Lubricants	103
Zollschrauben / -muttern	Screws / Nuts	104
Fahrzeugidentifikation	Car Specification	105
Technische Informationen	Technical Data	106
Verkaufs- u. Lieferbedingungen	Terms & Conditions	107

No.	Bezeichnung	Description	Anzahl/Qty.
ZK01MGA-08	Austauschzylinderkopf 1500/1600	Exchange cylinder head 1500/1600	1
ZK02MGA-08	Austauschzylinderkopf 1600 MK2	Exchange cylinder head 1600 MK2	1
K4SPT	Wasserthermostat 74 C.	Water thermostat 74 C.	1
K4ASPT	Wasserthermostat 82 C.	Water thermostat 82 C.	1
EM05MGA-50	MG-Zeichen Metall	Plate rocker cover „MG“	1
ZK05MGA-08	Krümmer-Stehbolzen „kurz“ außen	Manifold stud outer „short“	2
ZK06MGA-08	Krümmer-Stehbolzen „lang“ innen	Manifold stud inner „long“	4
EM06MGA-50	Westlake Patent-Zeichen Metall	Plate rocker cover „Westlake patent“	1
ZK07MGA-08	Aluminium-Ventildeckel poliert	Alloy rocker cover polished	1
ZK08MGA-08	Öleinfülldeckel	Oil filler cap	1
ZK08AMGA-08	Öleinfülldeckel verchromt (zu ZK07MGA-08)	Oil filler cap „chrome“ (for no. ZK07MGA-08)	1
ZK09MGA-08	Ventildeckel-Dichtung	Rocker cover gasket	1
ZK11MGA-08	Hutmutter Ventildeckel „verchromt“	Dome nut rocker cover „chrome“	2
ZK12MGA-08	Unterlegscheibe Ventildeckelmutter	Washer rocker cover nut	2
ZK14MGA-08	Distanzhülse Ventildeckelmutter	Rock cover spacer	2
ZK16MGA-08	Gummidichtring Ventildeckelmutter	Rubber washer rocker cover	2
ZK17MGA-08	Verschlussstopfen	Brass plug	1
ZK19MGA-08	Thermostat-Dichtung	Thermostat gasket	1
K21MGA-15	Deckel Thermostat-Gehäuse	Cover thermostat housing	1
ZK24MGA-08	Stehbolzen Thermostat-Gehäuse	Stud thermostat housing	3
K25MGA-32	Dichtung Heizungsventil	Heater valve gasket	1
ZK26MGA-08	Abdeckplatte Heizungskanal	Plate, blanking	1
ZK30MGA-08	Befestigungsniete	Pivot rivet	4
ZK31MGA-08	Stehbolzen Kipphebelbock „lang“	Stud rocker cover „long“	2
ZK32MGA-08	Stehbolzen Kipphebelbock „kurz“	Stud rocker cover „short“	2
ZK33MGA-08	Kipphebelwelle	Rocker shaft	1
ZK36MGA-08	Kipphebel	Rocker	8
ZK37MGA-08	Kipphebelbüchse	Rocker bush	8
ZK38MGA-08	Auspuffkrümmer-Dichtung	Manifold gasket	1
ZK39MGA-08	Zylinderkopfdichtung	Cylinder head gasket	1
ZK65SPT	Zylinderkopfmutter	Cylinder head nut	11
ZK65SPTR	Zylinderkopfmutter, hochfest	Cylinder head nut, competition	11
ZK66SPTR	Unterlegscheibe Zylinderkopfmutter, spez. hart	Plain washer under cylinder head nuts, hardened	11
MÖ	Motoröl 20W50, pro Liter	Motor oil 20W50, per liter	A/R
MÖRACE	Motoröl 20W50 Racing für Sportzwecke, je Liter	Motor oil 20W50 Racing, per liter	A/R

Hinweis**Note:**

Abb./Fig.MGB

Motorenüberholung in unserer eigenen Werkstatt!
Auf unsere Austausch-Motore und AT-Zylinderköpfe
gewähren wir **2 Jahre Garantie**. (Überholung des
eigenen Motors möglich - bitte fragen Sie nach)
Beachten Sie auch unsere Hinweise auf Seite 41!

Engines will be refurbished and remounted in our own
workshop! For our rebuild engines & cylinder heads
we **guarantee for 2 years**.
(Rebuilding of your existing engine possible
- please feel free to ask for)
Please refer to our notes on page 41 !

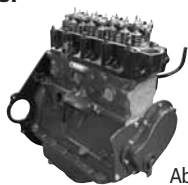
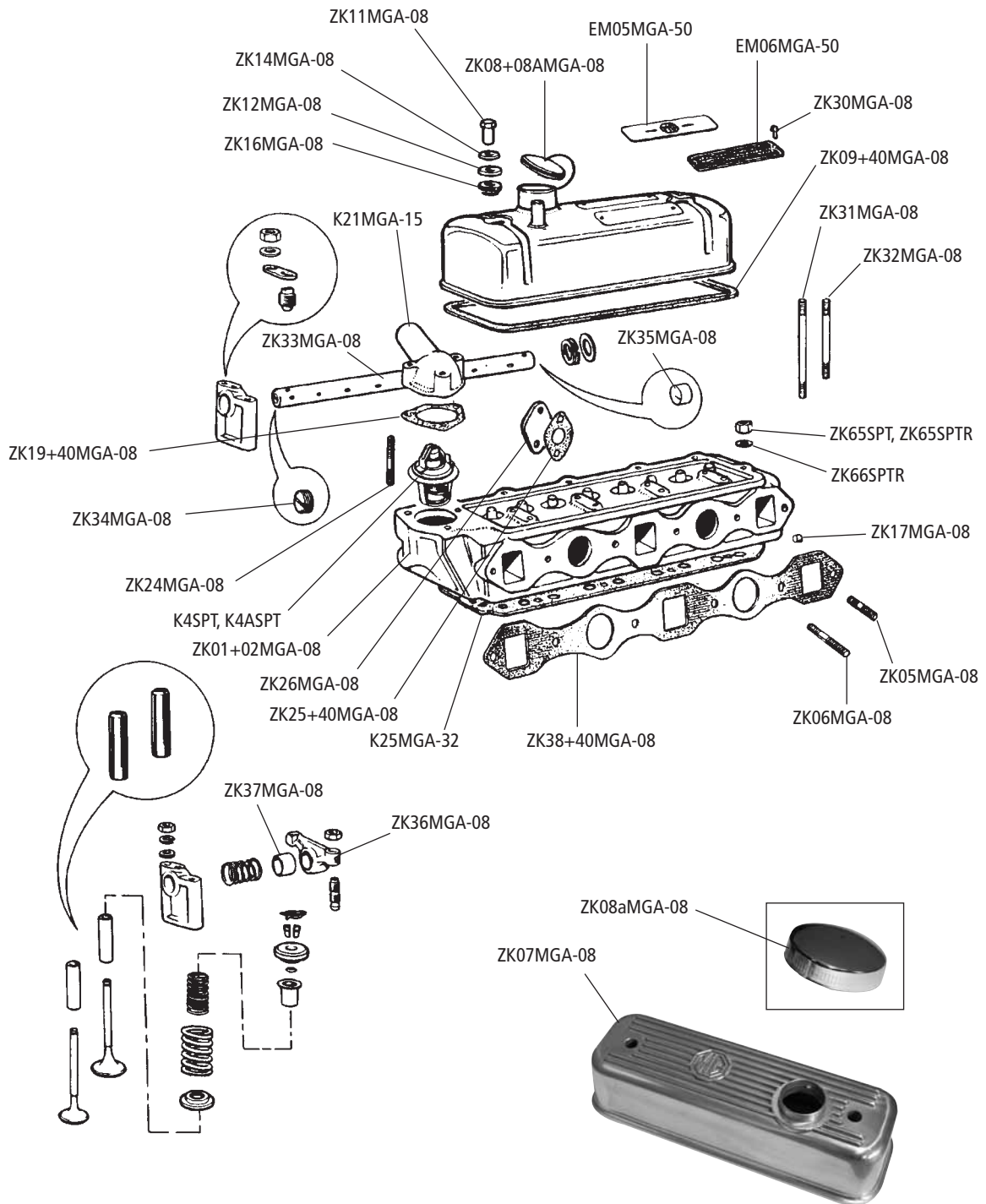

Hinweis 
Note:

Austauschteile können grundsätzlich erst nach Eingang des Altteiles versandt werden. Diese sind immer vorab in komplettem und gereinigtem Zustand anzuliefern!

As a matter of principle, parts which are available in exchange can only be dispatched after receipt of the old/used unit. Please supply us exchange parts complete and cleaned.

No.	Bezeichnung	Description	Anzahl/Qty.
ZK01MGA-09	Ventileinstellschraube	Screw adjusting rocker	8
ZK04MGA-09	Druckscheibe	Washer	2
ZK05MGA-09	Kipphebel-Distanzfeder	Spring rocker spacing	3
ZK06MGA-09	Lagerbock Kipphebel (mit Ölkanalöffnung)	Pedestal rocker shaft screwed	1
ZK07MGA-09	Lagerbock Kipphebel	Pedestal rocker shaft plain	3
ZK08MGA-09	Feststellschraube Kipphebelwelle	Screw locating rocker shaft	1
ZK09MGA-09	Halteplatte	Plate locking	1
M5/16"	Mutter Stehbolzen Lagerbock Kipphebelwelle	Nut on stud rocker pedestal	1
ZK11MGA-09	Ventilkeil	valve cotter - early	16
ZK13MGA-09	Ventilschaft-O-Ring	O-ring valve shaft	8
ZK14MGA-09	Ventilteller	Valve cup upper	8
ZK15MGA-09	Ölführung Innere Ventilfeeder	Oil deflector	8
ZK16MGA-09	Satz Ventilfeeder (16 tlg)	Valve spring set (16 pcs)	1
ZK17MGA-09	Satz Ventilfeeder „verstärkt“ (16 tlg)	Valve spring set uprated (16 pcs)	1
ZK18MGA-09	Unterlage Ventilfeeder	Collar valve spring	8
ZK19MGA-09	Einlaßventil 1500/1600	Inlet valve 1500/1600	4
ZK20MGA-09	Einlaßventil 1600 MK2	Inlet valve 1600 MK2	4
ZK21MGA-09	Auslaßventil 1500/1600 MK2	Exhaust valve 1500/1600 MK2	4
ZK23MGA-09	Einlaß-Ventilführung	Inlet valve guide	4
ZK24MGA-09	Einlaß-Ventilführung (Competition/Bronze)	Inlet valve guide (competition/bronze)	4
ZK25MGA-09	Auslaß-Ventilführung	Exhaust valve guide	4
ZK26MGA-09	Auslaß-Ventilführung (Competition/Bronze)	Exhaust valve guide (competition/bronze)	4
ZK27MGA-09	Satz Ventilführungen (Competition/Bronze) (8 tlg)	Valve guides set (competition/bronze) (8 pcs)	1
ZK40MGA-12	Oberer Motordichtsatz	Gasket set top	1
ZK51MGA-09	Klammer Ventilkeile	Clip valve collets	8
ZK85SPT	Mutter Ventileinstellschraube	Nut adjusting rocker screw	8
F5/16"	Federring	Washer spring	1

Hinweis
Note:



Anmerkung zu Nr. ZK24/26/27MGA-09: „Bronze“-
Ventilführungen – weniger Reibung, größere Zuverlässigkeit.
Für Motorsportzwecke.

Note to no ZK24/26/27MGA-09: Bronze-valve guides- extra
reliability and less friction wear especially when used under
duress. For competition use only.

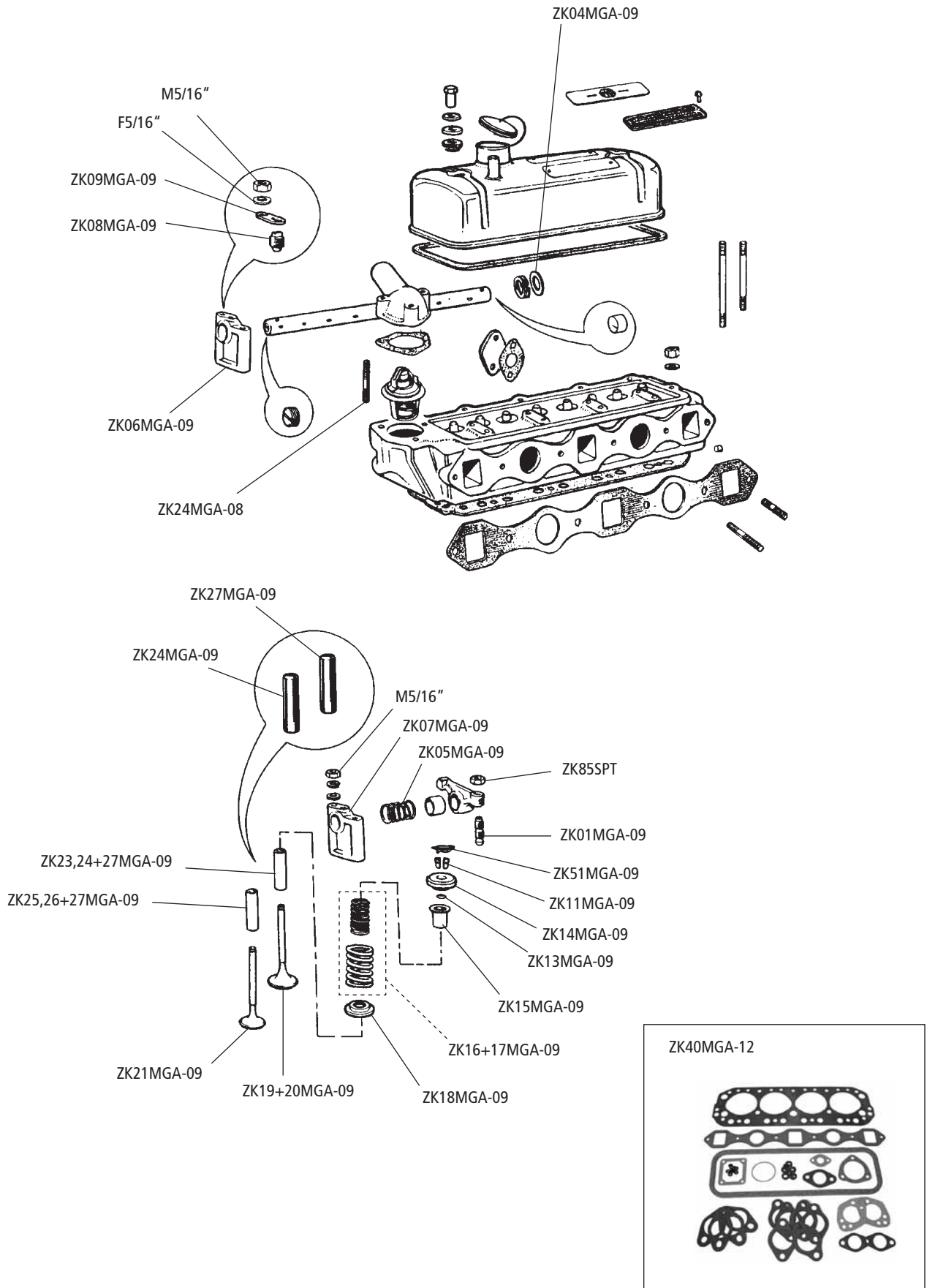

No.	Bezeichnung	Description	Anzahl/Qty.
M03MGA-10	Buchse Kurbelwelle	Crankshaft bush	1
M04MGA-10	Kettenrad Kurbelwelle	Crankshaft gear „duplex“	1
M05MGA-10	Sicherungskeil	Crankshaft key	2
M05MGA-12	Halteblech Nockenwelle	Camshaft retaining plate	1
M5TR4	Ausgleichsscheibe „0.006“	Shim washer „0.006“	A/R
M08MGA-10	Satz Hauptlager 1500/1600 (*)	Main bearings set 1500/1600 (*)	1
M13MGA-10	Satz Hauptlager 1600 MK2 (*)	Main bearings set 1600 MK2 (*)	1
M19MGA-10	Satz Pleuellager (*)	Big end bearings set (*)	1
M26MGA-10	Satz Anlaufscheiben (*)	Set thrust washers (*)	1
M31MGA-10	Sicherungsblech Pleuelschraube	Tab washer connecting rod bolt	4
M32MGA-10	Pleuelschraube	Connecting rod bolt	8
M34MGA-10	Hauptlager-Mutter	Nyloc nut connecting rod	6
M34MGA-12	Sicherungsblech Keilriemenscheibe	Lock plate crank pulley	1
M35MGA-10	Stehbolzen Hauptlagerbock	Stud main bearing cap	6
M37MGA-10	Satz Sicherungsbleche (10 tlg)	Lock tab set (10 pcs)	1
M38MGA-10	Schwungscheibe	Flywheel	1
M39MGA-10	Starterkranz auf Schwungscheibe	Starter gear ring on flywheel	1
M40MGA-10	Sichungsblech Schwungscheibe	Lock plate flywheel	3
M41MGA-10	Befestigungsschraube Schwungscheibe	Bolt flywheel/crankshaft	6
M3/8“	Mutter Schwungscheiben-Schraube	Nut flywheel bolt	6
M43MGA-10	Paßstift Kupplungsscheibe	Dowel clutch to flywheel	2
M44MGA-10	Klemmschraube Kolbenbolzen 1500/1600	Bolt clamping con rod small end 1500/1600	4
M45MGA-10	Klemmschraube Kolbenbolzen 1600 MK2	Bolt clamping con rod small end 1600 MK2	4
M01MGA-11	Satz (4) Kolben 1500 (*)	Piston set (4 pcs) 1500 (*)	1
M08MGA-11	Satz (4) Kolben 1600 (*)	Piston set (4 pcs) 1600 (*)	1
M14MGA-11	Satz (4) Kolben 1622 (*)	Piston set (4 pcs) 1622 (*)	1
M19MGA-11	Laufbuchse	Cylinder liner	4
M20MGA-11	Satz Kolbenringe (4 Kolben/je 4 Ringe) 1500 (*)	Piston ring set 1500 (4 pistons/ 4-rings each) (*)	1
M25MGA-11	Satz Kolbenringe (4 Kolben/je 4 Ringe) 1600 (*)	Piston ring set 1600 (4 pistons/ 4-rings each) (*)	1
M30MGA-11	Satz Kolbenringe (4 Kolben/je 4 Ringe) 1622 (*)	Piston ring set 1622 (4 pistons/ 4-rings each) (*)	1
M25MGA-13	Umrüstsatz Einweg-Ölfilterpatrone	Spin on throw-away oil filter kit	1
K33TR	Einweg-Ölfilterpatrone für M25MGA-13	Spin on throw-away oil filter (to use with M25MGA-13)	1
M35MGA-11	Ölpumpe	Oil pump	1
M36MGA-11	Dichtung Ölpumpe/Filter	Gasket pump to strainer	1
M37MGA-11	Ölpumpen-Sieb	Oil strainer	1
M38MGA-11	Dichtung Ölpumpe/Motorblock	Gasket pump to engine block	1
M39MGA-11	Ölpumpen-Antriebsritzel	Spindle oil pump driving	1
M40MGA-11	Dichtung Kettenspanner	Tensioner gasket	1
M41MGA-11	Kettenspanner	Timing chain tensioner	1
M42MGA-11	Sicherungsblech Kettenspanner	Chain tensioner lock tap	1
M45MGA-11	Steuerkette	Timing chain	1
M46MGA-11	Kettenrad Nockenwelle	Camshaft gear	1
M47MGA-11	Sicherungsblech	Lock washer	1
M48MGA-11	Mutter Kettenrad Nockenwelle	Retaining nut camshaft gear	1
M05MGA-12	Halteplatte Nockenwelle	Camshaft retaining plate	1
M50MGA-11	Ölfilter-Einsatz	Oil filter paper element	1
M51MGA-11	Stehbolzen Ölpumpe	Stud oil pump	2/3
M74MGB-02	Ölschleuderblech	Oil thrower	1
MÖ	Motoröl 20W50, pro Liter	Motor oil 20W50, per liter	A/R
MÖRACE	Motoröl 20W50 Racing für Sportzwecke, pro Liter	Motor oil 20W50 Racing for competition use, per liter	A/R

(*) Bitte Größe angeben

(*) Please refer dimension

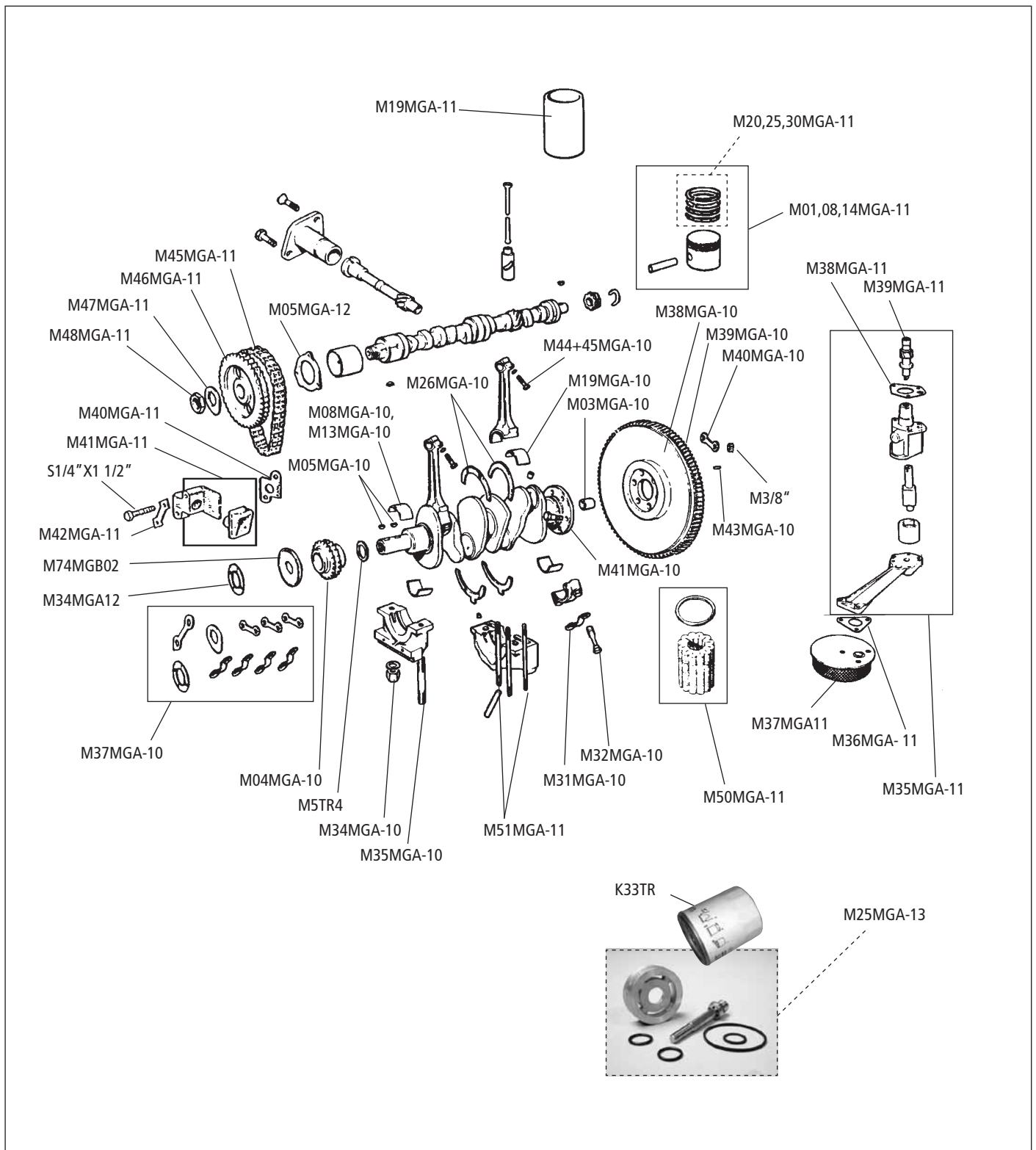

Hinweis 
Note:

Anmerkung zu M25MGA-13:
 Dieser Umrüstsatz auf eine Einweg-Ölfilterpatrone macht den regelmäßigen Ölwechsel zu einer sauberen, einfachen Angelegenheit.

Note to no. M25MGA-13:
 The use of a „Spin-on“-oil filter will make routine oil changing much cleaner and easier operation.

No.	Bezeichnung	Description	Anzahl/Qty.
M1MGA-1500	AT-Motor 1500cc *	Engine 1500cc, exchange *	1
M1MGA-1600	AT-Motor 1600cc *	Engine 1600cc, exchange *	1
M1MGA-1622	AT-Motor 1622cc *	Engine 1622cc, exchange *	1
M01MGA-12	Nockenwelle (neu)	Camshaft	1
M02MGA-12	Austausch-Nockenwelle	Exchange camshaft	1
M03MGA-12	Satz Nockenwellenlager	Set camshaft bearing	1
M04MGA-12	Sicherungskeil Nockenwelle	Camshaft woodruff key	1
M05MGA-12	Halteblech Nockenwelle	Camshaft retaining plate	1
M06MGA-12	Antriebsritzel Drehzahlmesser	Gear tachometer driving	1
M07MGA-12	Sicherungsring	Camshaft circlip	1
M09MGA-12	Stösseltasse	Cam follower	8
M10MGA-12	Stößelstange	Push rod	8
M15MGA-12	Verteilerantriebswelle	Distributor driving spindle	1
M16MGA-12	Ölwanne	Oil sump	1
M17MGA-12	Ölwannendichtung	Gasket oil sump	1
M18MGA-12	Dichtung Motorplatte hinten	Gasket mounting plate to block	1
M19MGA-12	Korkdichtung Hauptlagerschalen	Cork gasket front + rear bearing cap	2
M20MGA-12	Dichtung Stirndeckel 1500 bis Gb258	Timing chain cover gasket 1500 up to Gb258	1
M21MGA-12	Dichtung Stirndeckel 1500 ab Gb259/1600/1622	Timing chain cover gasket 1500 from Gb259/1600/1622	1
M22MGA-12	Filz-Dichtring 1500/1600/1622 bis Gc82621	Felt seal timing cover 1500/1600/1622 up to Gc8262	1
M23MGA-12	Neopren-Simmerring 1622 ab Gc8263	Neoprene seal timing cover 1622 from Gc8263	1
M24MGA-12	Dichtung Motorplatte vorne	Front engine plate gasket	1
M25MGA-12	Öl-Ablafschraube	Oil drain plug	1
M27MGA-12	Wasser-Ablasshahn	Water drain tap	1
M28MGA-12	Fiberscheibe	Fibre washer	1
M29MGA-12	Adapter Öldruckleitung	Union oil pressure gauge pipe	1
M31MGA-08	Zylinderkopf-Stehbolzen (lang)	Cylinder head stud „long“	4
M32MGA-08	Zylinderkopf-Stehbolzen (kurz)	Cylinder head stud „short“	7
E33MGA-35	Öldruckschlauch	Gauge pipe flexible	1
M34MGA-12	Sicherungsblech Keilriemenscheibe	Lock plate crank pulley	1
M35MGA-12	Kurbelwellen-Mutter	Starter dog	1
M36MGA-12	Mutter Öldruckventil	Cap nut oil pressure valve	1
M37MGA-12	Kupferdichtring Öldruckventil	Copper washer	1
M38MGA-12	Feder Öldruckventil	Spring oil pressure valve	1
M39MGA-12	Öl-Überdruckventil	Oil pressure relief valve	1
M40MGA-12	Motordichtsatz unten	Bottom gasket set	1
M41MGA-12	Korkdichtung Seitendeckel Motor	Side cover gasket (cork)	2
FSF42	Froststopfen	Core plug engine	4
M42MGA-12	Abdeckplatte Motor hinten	Cover tappet inspection rear	1
M43MGA-12	Flache Scheibe (lang)	Flat washer plate (long)	5
M44MGA-12	Flache Scheibe (kurz)	Flat washer plate (short)	4
M45MGA-12	Abdeckplatte Loch Benzinpumpe	Blanking plate petrol pump	1
SR64	Dichtring Ölablafschraube/Wasser-Ablasshahn	Washer oil/water drain plug	1/2
M114MGA	Froststopfen Satz	Core plug engine, set	1
M200MGA	Motor-Nummer Schild	Plate, engine no.	1
M200aMGA	Niete	Rivet	2
G207SPT	Sicherungskeil Nockenwelle	Key camshaft	1
MD17SPT	Dauerplast. Universaldichtung "Marston" 80ml	Universal jointing compound "Marston" 80ml	A/R
MD17aSPT	Hochwertige Silikondichtmasse - schwarz "Hylosil" 200ml	Silicone sealant - black "Hylosil" 200ml	A/R

* nur im Austausch mit dem eigenen Motor

* only exchange of your existing engine possible!

Hinweis
Note:

Abb./Fig.MGB

Motorenüberholung in unserer eigenen Werkstatt!
Auf unsere Austausch-Motore und AT-Zylinderköpfe
gewähren wir **2 Jahre Garantie**. (Überholung des
eigenen Motors möglich - bitte fragen Sie nach)
Beachten Sie auch unsere Hinweise auf Seite 41!

Engines will be refurbished and remounted in our own
workshop! For our rebuild engines & cylinder heads
we **guarantee for 2 years** .
(Rebuilding of your existing engine possible
- please feel free to ask for)
Please refer to our notes on page 41 !

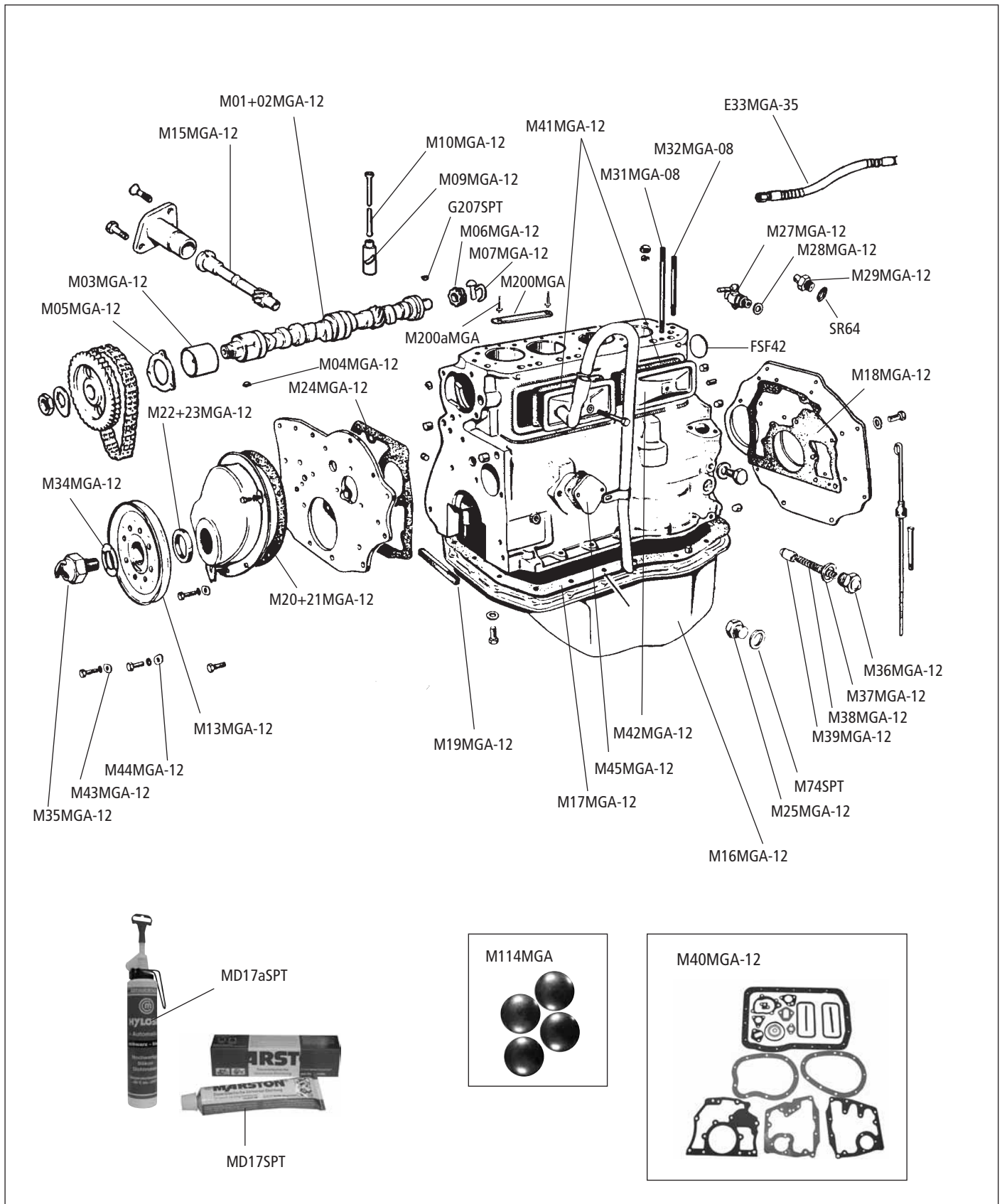

Hinweis 
Note:

Austauschteile können grundsätzlich erst nach Eingang des Altteiles versandt werden. Diese sind immer vorab in komplettem und gereinigtem Zustand anzuliefern!

As a matter of principle, parts which are available in exchange can only be dispatched after receipt of the old/used unit. Please supply us exchange parts complete and cleaned.

No.	Bezeichnung	Description	Anzahl/Qty.
M01MGA-13	Ölmeßstab „gerade“ 1500/1600 bis 16Ga/H9648	Oil dip stick „straight“ 1500/1600 up to 16Ga/H9648	1
M02MGA-13	Ölmeßstab „gebogen“ 1600/1622 ab 16Ga/H9649	Oil dip stick „curved“ 1600/1622 from 16Ga/H9649	1
M03MGA-13	Führungsrohr Ölmeßstab	Dip stick tube	1
M04MGA-13	Gummikappe Ölmeßstab	Dip stick tube gaiter	1
M07MGA-13	Froststopfen	Core plug engine	4
M08MGA-13	Motoraufhängung 1500/1600/1622 rechts	Engine mounting 1500/1600/1622 right hand	1
M09MGA-13	Motoraufhängung 1600 MK2 De Luxe + Twin Cam rechts	Engine mounting 1600 MK2 de Luxe + Twin Cam right hand	1
M10MGA-13	Motoraufhängung links, alle Modelle	Engine mounting left hand, all models	1
M11MGA-13	Halteblech Motoraufhängung rechts	Engine mounting bracket right hand	1
M12MGA-13	Halteblech Motoraufhängung links	Engine mounting bracket left hand	1
M13MGA-12	Keilriemenscheibe Kurbelwelle	Crank pulley	1
K14MGA	Ölkühlerschlauch stahlummantelt	Oil cooler hose steel reinforced	2
M15MGA-13	Lichtmaschinenhalter	Dynamo mounting bracket	1
M16MGA-13	Sockelschraube Lichtmaschine	Dynamo mounting pillar	1
M17MGA-13	Einstellhebel Lichtmaschine	Dynamo adjusting link	1
M18MGA-13	Entlüftungsleitung	Breather pipe	1
E24MGA-33	Erdungskabel Motor/Chassis	Earth strap engine/chassis	1
G63MGA-19	Getriebeaufhängung hinten	Gearbox mounting	1
K17SPT	Ölkühler 13-reihig	Oil cooler radiator 13 row	1
K30TR	Ölkühler 16-reihig	Oil cooler radiator 16 row	1
M24MGA-13	Dichtung Ölkühler/Frontblech	Seating gasket oil cooler	1
M27MGA-13	Gehäuse Drehzahlmesserantrieb	Housing rev. counter drive	1
M28MGA-13	Dichtung Drehzahlmesserantrieb an Motorblock	Gasket rev. counter drive / engine block	1
M29MGA-13	Ablaßstopfen	Plug drain block	1
M30MGA-13	Stopfen	Plug	1
M74SPT	Dichtscheibe Ablaßstopfen	Washer plug drain block	1

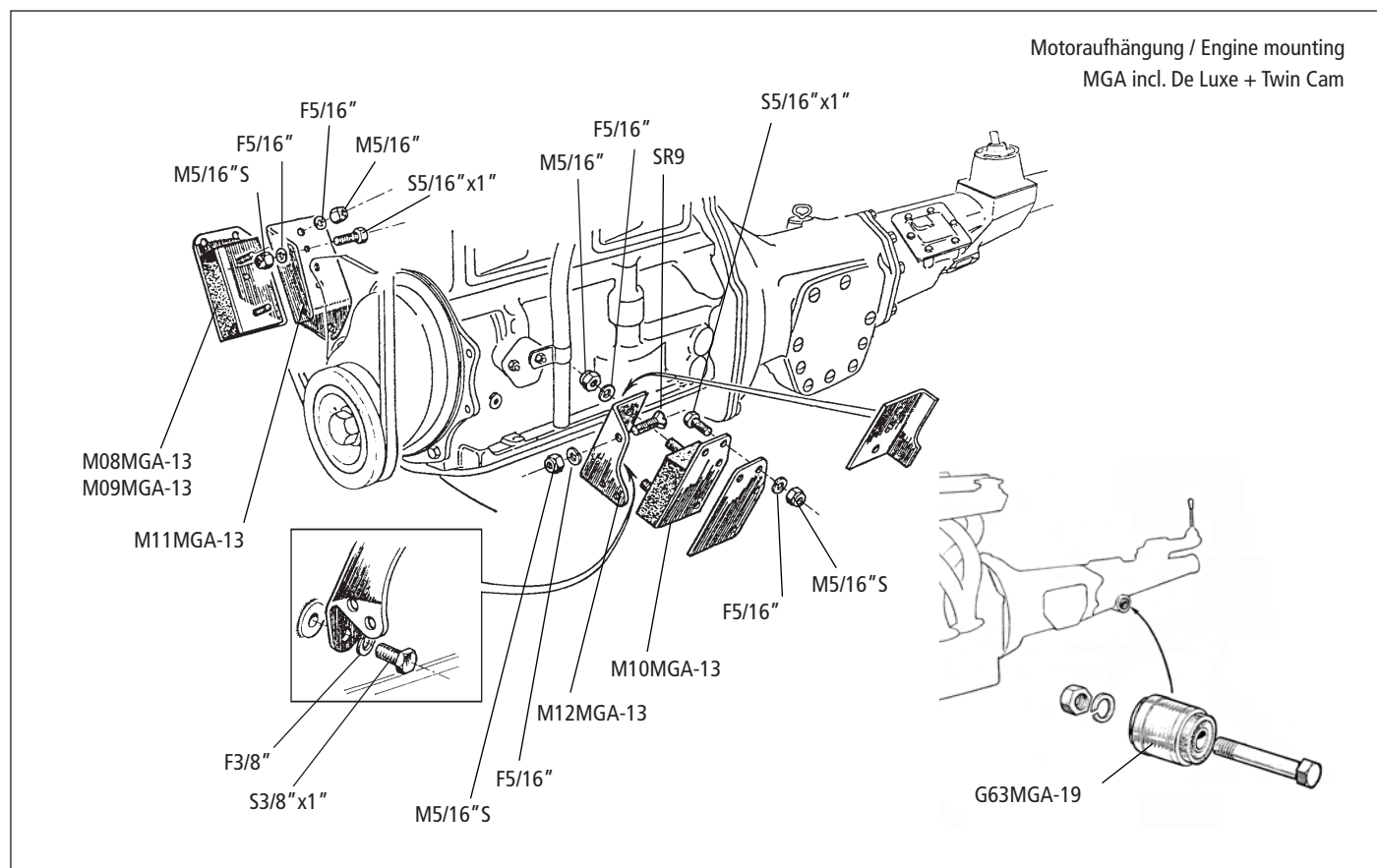

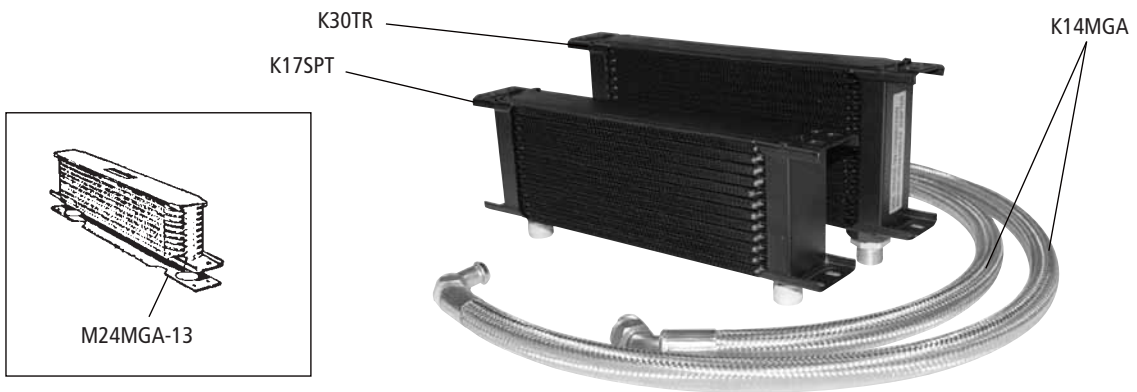
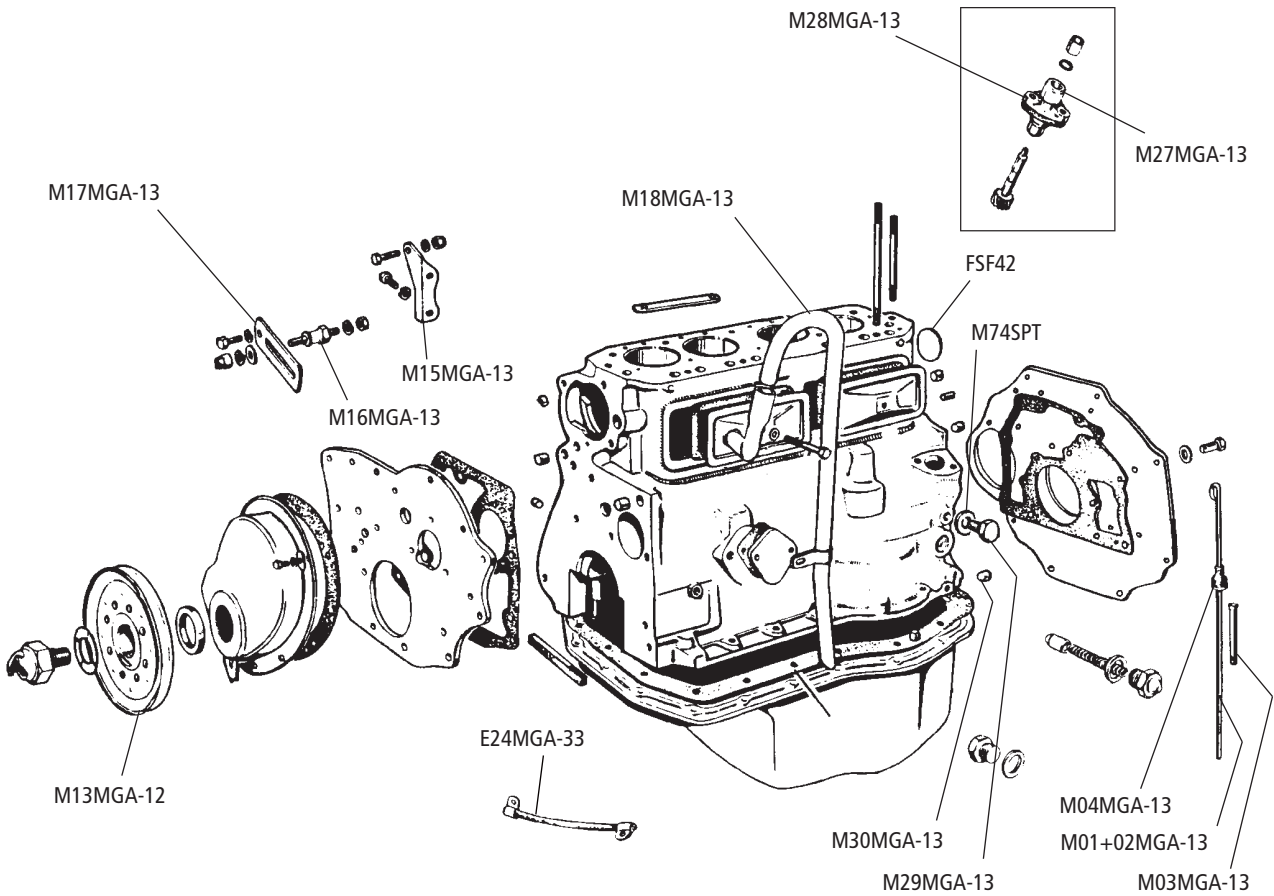

No.	Bezeichnung	Description	Anzahl/Qty.
M0MGA/TC	AT-Motor Twin Cam (Überholung nur des eigenen Motors möglich)	Engine Twin Cam, exchange (Only reconditioning of your existing engine possible!)	1
obere Abb.		top illustration	
M03MGA-12	Nockenwelle-Lager-Satz	Cam bearing set	1
M19MGA-11	Laufbuchse	Liner	4
M19MGA-12	Korkdichtung Hauptlagerschalen	Gasket main bearing cap	2
M20MGA/TC	Kolbensatz	Piston set	1
M21MGA/TC...	Satz Kolbenringe - bitte Größe angeben	Piston ring set - please refer dimension	1
M27MGA-12	Wasser-Ablasshahn	Drain tap eng block	1
M28MGA-13	Dichtung Drehzahlmesserantrieb	Gasket tacho drive	1
M34MGA-10	Hauptlager-Mutter	Nut main cap	6
M35MGA-10	Stehbolzen Hauptlagerbock	Stud - main end	6
M38MGA/TC	Stehbolzen Zylinderkopf MGA Twin Cam	Stud cylinder head Twin Cam	10
FSF42	Froststopfen Motorblock (42 mm)	Core plug engine block (42mm)	4
M43MGA/TC	Stehbolzen 5/16x3/8" UNC	Stud 5/16x3/8" UNC	2
M47MGA/TC	Abdeckblech für Anschluß Benzinpumpe	Blanking plate	1
M48MGA/TC	Dichtung	Gasket	1
M52MGA/TC	Passstift Motorplatte unten hinten	Dowel engine mounting plate, bottom rear	2
M74SPT	Kupferdichtring für Ölablaßschraube	Copper washer	1
mittlere Abb.		centre illustration	
M01MGA/TC	Dichtung Motorplatte hinten	Gasket engine mounting plate, rear	1
M04MGA-12	Klemmkeil Nockenwelle	Key camshaft	1
M05MGA-10	Sicherungskeil	Key camshaft	1
M07MGA-12	Sicherungsring	Lock circlip	1
M13MGA/TC	Hitzeschild	Heatshield	1
M18MGA/TC	Entlüftungsrrohr	Vent pipe	1
M19MGA-10...	Satz Pleullager - bitte Größe angeben	Con rod bearing set - please refer dimension	1
M31MGA-10	Sicherungsblech Pleuelschraube MGA/MGB	Tab washer connecting rod bolt	4
M32MGA-10	Pleuelschraube	Con rod bolt	8
M35MGA-12	Kurbelwellen-Mutter	Nut crankshaft	1
M41MGA-12	Dichtung Seitendeckel Motor	Gasket engine side cover	2
M42MGB-12	Motor-Seitendeckel hinten	Engine side cover rear	1
M48TR4	Pleuelbüchse	Bush	1
G207SPT	Keil Nocke Overdrive	Key woodruff overdrive	1
M230MGA/TC	Halteblech Nockenwelle	Plate retaining camshaft	1
M234MGA/TC	Antriebsritzel	Tacho drive gear	1
untere Abb.		bottom illustration	
M03MGA-10	Buchse Kurbelwelle	Bush crankshaft spigot	1
M13MGA-10/...	Satz Hauptlager - bitte Größe angeben (STD, 0,010", 0,020", 0,030" oder 0,040")	Main bearings set - please refer dimension (STD, 0,010", 0,020", 0,030" or 0,040")	1
M26MGA-10/..	Satz Anlaufscheiben - bitte Größe angeben (STD, 0,003", 0,005", 0,030" oder 0,010")	Thrust washer set - please refer dimension (STD, 0,003", 0,005", 0,030" oder 0,010")	1
M39MGA-10	Anlasser-Zahnkranz Schwungscheibe MGA/MGB bis 67/GB Motor	Starter ring gear on flywheel MGA/MGB to 67/GB engine	1
M40MGA-10	Sicherungsblech Schwungscheibe	Washer lock flywheel	3
M41MGA-10	Befestigungsbolzen Schwungscheibe	Bolt pulley crankshaft/flywheel	6
M203MGA/TC	Simmerring Motor hinten	Crankshaft oil seal rear	1

Hinweis 
Note:



Abb./Fig.MGB

Motorenüberholung in unserer eigenen Werkstatt!
 Auf unsere Austausch-Motore und AT-Zylinderköpfe
 gewähren wir **2 Jahre Garantie**. (Überholung des
 eigenen Motors möglich - bitte fragen Sie nach)
 Beachten Sie auch unsere Hinweise auf Seite 41!

**Austauschteile können grundsätzlich erst
 nach Eingang des Altteiles versandt werden.
 Diese sind immer vorab in komplettem und
 gereinigtem Zustand anzuliefern!**

Engines will be refurbished and remounted in our own
 workshop! For our rebuild engines & cylinder heads
 we **guarantee for 2 years**. (Rebuilding of your existing
 engine possible - please feel free to ask for)
 Please refer to our notes on page 41 !

**As a matter of principle, parts which are available
 in exchange can only be dispatched after receipt of
 the old/used unit. Please supply us exchange parts
 complete and cleaned.**

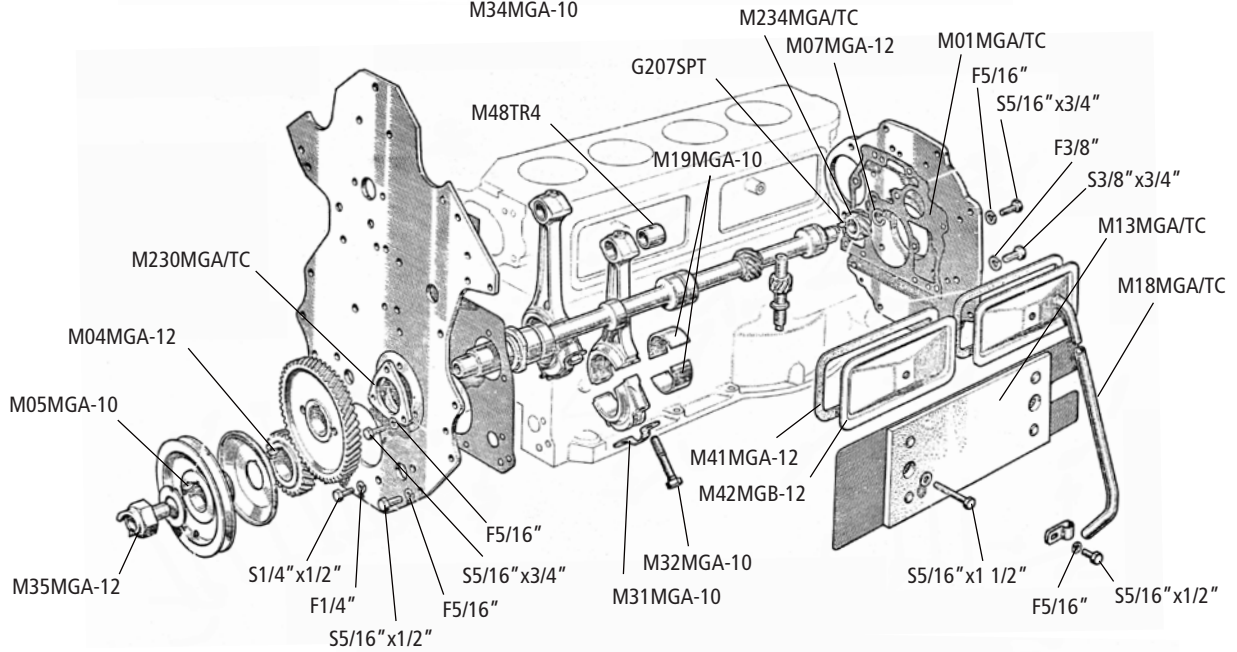
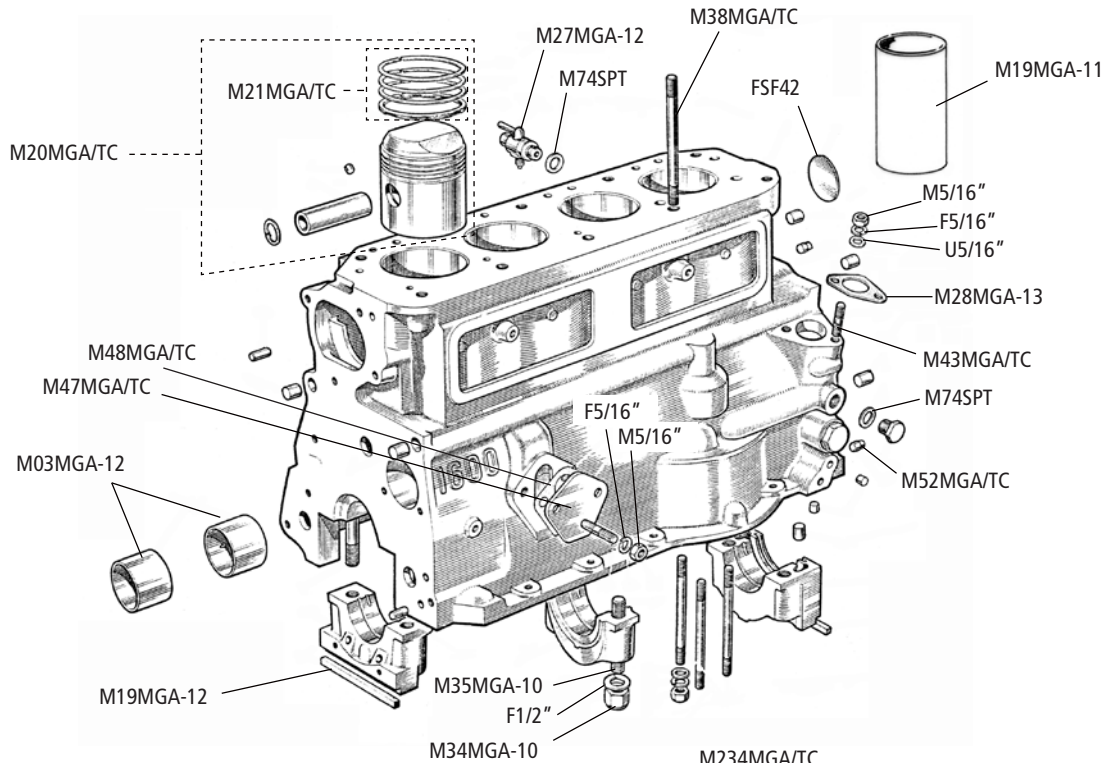
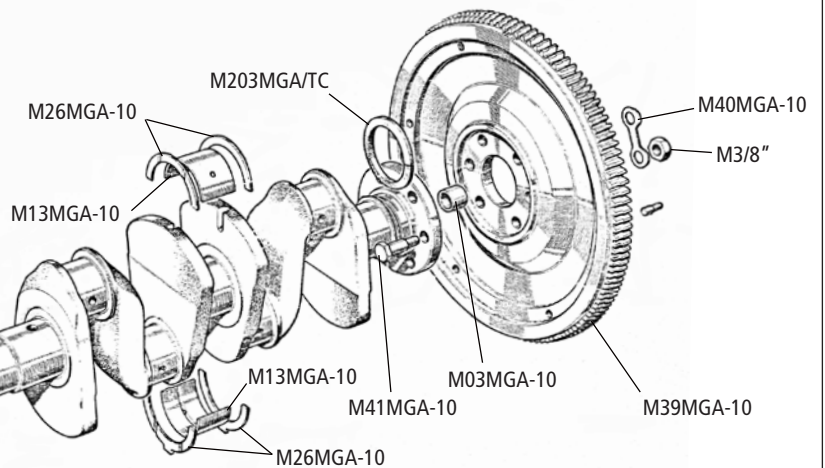
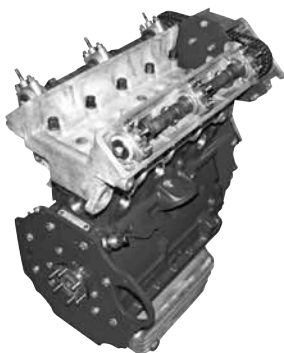
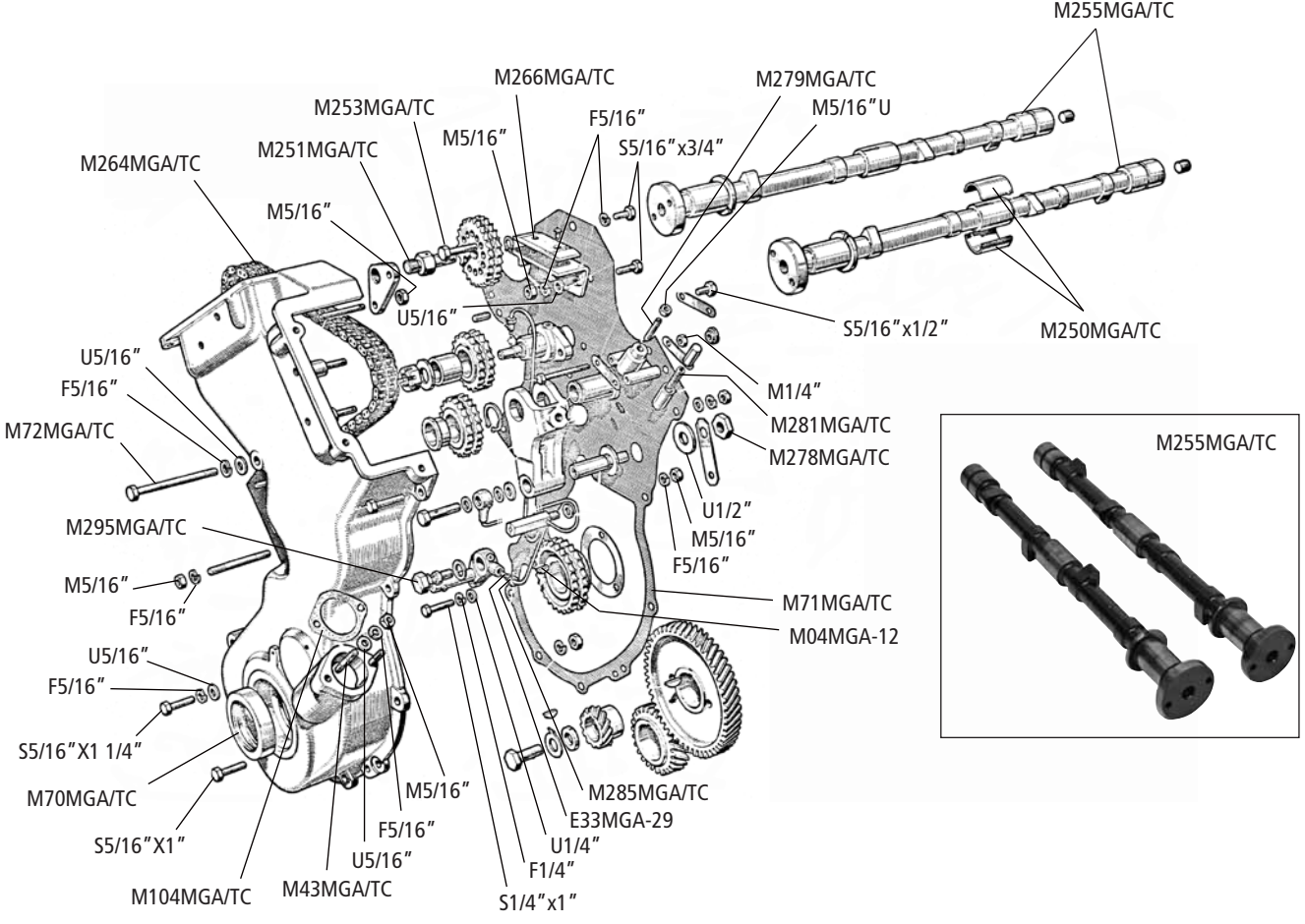
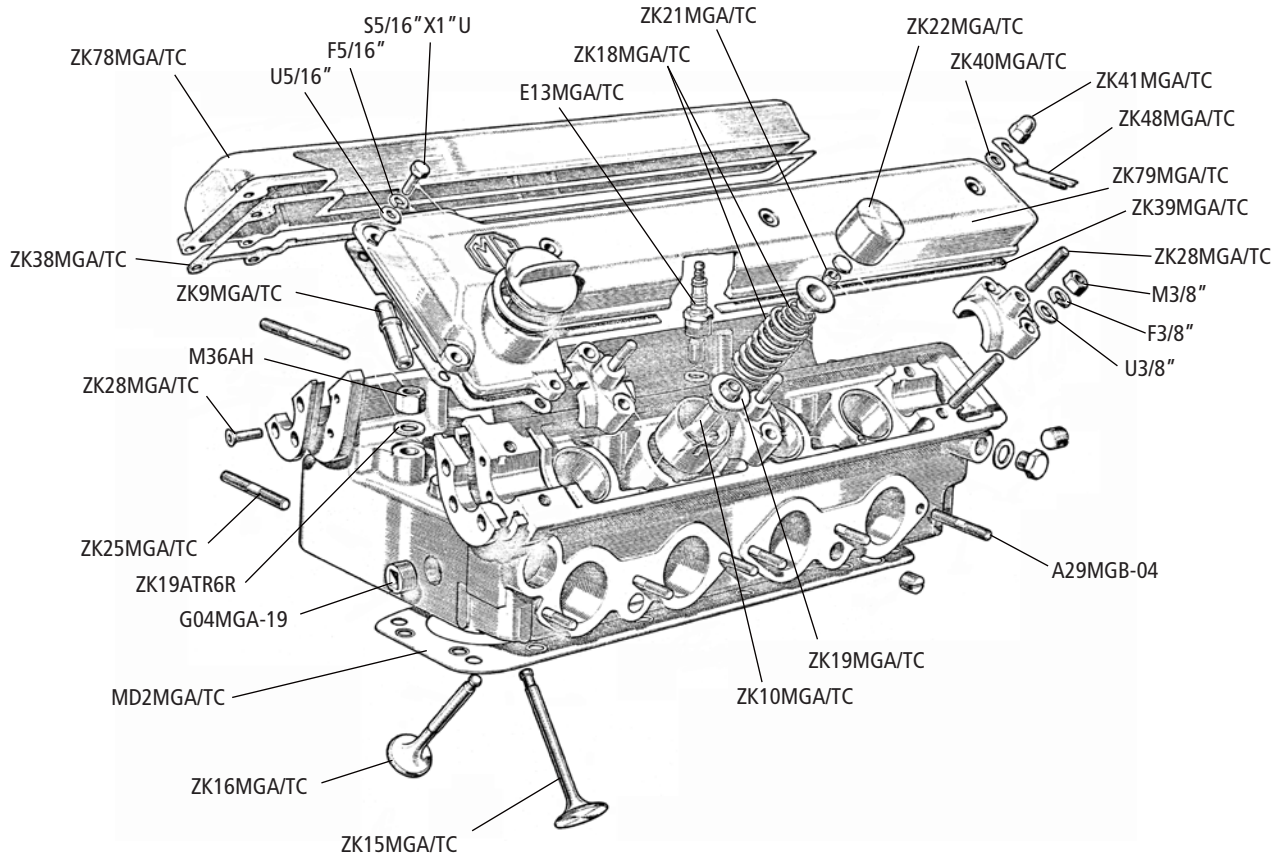

Fig.: AT-Motor / Exch. Engine
MGA Twin Cam



No.	Bezeichnung	Description	Anzahl/Qty.
	obere Abb.	top illustration	
MD2MGA/TC	Zylinderkopfdichtung MGA Twin Cam	Gasket cylinder head Twin Cam	1
G04MGA-19	Ölverschluss-Schraube	Drain plug	5
ZK8MGA/TC	Stehbolzen 5/16x1/2" UNC	Stud 5/16x1/2" UNC	6
ZK9MGA/TC	Ventilführung Einlaß MGA Twin Cam (4 Stück benötigt)	Valve guide inlet MGA Twin Cam (4 pc. needed)	4
ZK10MGA/TC	Ventilführung Auslaß MGA Twin Cam (4 Stück benötigt)	Valve guide exhaust MGA Twin Cam (4 pc. needed)	4
E13MGA/TC	Zündkerze	Spark plug	4
ZK15MGA/TC	Einlaßventil MGA Twin Cam (4 Stück benötigt)	Inlet valve MGA Twin Cam (4 pc. needed)	4
ZK16MGA/TC	Auslaßventil MGA Twin Cam (4 Stück benötigt)	Exhaust valve MGA Twin Cam (4 pc. needed)	4
ZK18MGA/TC	Satz Ventildfedern (16 Stück im Set)	Valve spring set (set: 16 pc.)	1
ZK19ATR6R	U-Scheibe spezial hart 7/16"	Washer hard 7/16"	10
ZK19MGA/TC	Unterlegscheibe für Feder (unten)	Collar valve spring lower	8
ZK21MGA/TC	Ventilkeil	Half collet (cam follower)	A/R
ZK22MGA/TC	Ventilheber	Tappet bucket	8
ZK25MGA/TC	Stehbolzen 3/8" x 1 5/8" UNC	Stud 3/8 x1 5/8" UNC	5
ZK28MGA/TC	Senkkopschraube	Contersunk screw	6
A29MGB-04	Stehbolzen Abgaskrümmer	Manifold stud	6
M36AH	Mutter Zylinderkopf	Nut cylinder head	10
ZK38MGA/TC	Ventildeckeldichtung Einlaß-Seite	Gasket camcover inlet	1
ZK39MGA/TC	Ventildeckeldichtung Auslaß-Seite	Gasket camcover exhaust	1
ZK40MGA/TC	Dichtscheibe	Washer sealing	6
ZK41MGA/TC	Hutmutter	Cap nut	6
ZK48MGA/TC	Halter Ölmesstab	Bracket dipstick	1
ZK78MGA/TC	Ventildeckel Einlaß-Seite	Cam cover inlet	1
ZK79MGA/TC	Ventildeckel Auslaß-Seite	Cam cover exhaust	1
	untere Abb.	bottom illustration	
M04MGA-12	Klemmkeil	Half collet	1
E33MGA-29	Anschluss Schraube für Leitung	Nut male carb vacuum	2
M43MGA/TC	Stehbolzen	Stud	2
M70MGA/TC	Simmerring Motor vorne	Oil seal engine front	1
M71MGA/TC	Stirndeckeldichtung	Gasket, timing cover to front plate	1
M72MGA/TC	Schraube	Bolt	1
M104MGA/TC	Verteilerdichtung	Gasket	1
M250MGA/TC	Satz Nockenwellenlager	Camshaft bearing set	1
M251MGA/TC	Gewindebolzen Nockenwellenrad	Sprocket spindle	2
M253MGA/TC	Schraube Nockenwellenrad	Bolt sprocket	4
M255MGA/TC	Nockenwellenpaar	Camshaft, pair	1
M264MGA/TC	Steuerkette	Timing chain	1
M266MGA/TC	Führungsschiene Steuerkette	Damper camshaft gear	2
M278MGA/TC	Mutter	Nut	1
M279MGA/TC	Schraube	Adjuster screw	1
M281MGA/TC	Feder	Spring	1
M285MGA/TC	Dichtolive	Olive vacuum pipe	2
M295MGA/TC	Anschluss Schraube	Banjo bolt	1
MÖ	Motoröl 20W50, pro Liter	Motor oil 20W50, per liter	A/R
MÖRACE	Motoröl 20W50 Racing für Sportzwecke, pro Liter	Motor oil 20W50 Racing for competition use, per liter	A/R



No.	Bezeichnung	Description	Anzahl/Qty.
MD1MGA/TC	Oberer Motordichtsatz	Gasket set top	1
MD3MGA/TC	Unterer Motordichtsatz	Gasket set bottom	1
M17MGA-12	Ölwannen-Dichtung	Oil sump gasket	1
M25MGA-13	Umrüstsatz Einweg-Ölfilterpatrone	Spin on throw-away oil filter kit	1
K33TR	Einweg-Ölfilterpatrone für M25MGA-13	Spin on throw-away oil filter (to use with M25MGA-13)	1
M35MGA-11	Ölpumpe	Oil pump	1
M36MGA-11	Dichtung Filter/Ölpumpe	Gasket strainer to pump	1
M36MGA-12	Hutmutter Öldruckventil	Cap nut oil pressure valve	1
M37MGA-11	Sieb Ölpumpe	Strainer oil pump	1
M37MGA-12	Kupferdichtring	Copper washer	2
M38MGA-12	Feder Öldruckventil	Spring, oil pressure valve	1
M39MGA-11	Dichtung Ölpumpe/Gehäuse	Gasket oil pump/crank case	1
M39MGA-12	Öldruckventil Öldruck	Oil pressure relief valve	1
M50MGA-11	Ölfiltereinsatz	Oil filter paper element	1
M90MGA/TC	Ölablaßschraube	Drain plug	1
M96MGA/TC	Führungsrohr Öl-Messstab	Tube dipstick	1
M97MGA/TC	Öl-Messstab	Dipstick	1
M98MGA/TC	Gummikappe Ölmesstab	Washer dipstick tube	1
MD17SPT	Dauerplast. Universaldichtung "Marston" 80ml	Universal jointing compound "Marston" 80ml	A/R
MD17aSPT	Hochwertige Silikondichtmasse - schwarz "Hylosil" 200ml	Silicone sealant - black "Hylosil" 200ml	A/R

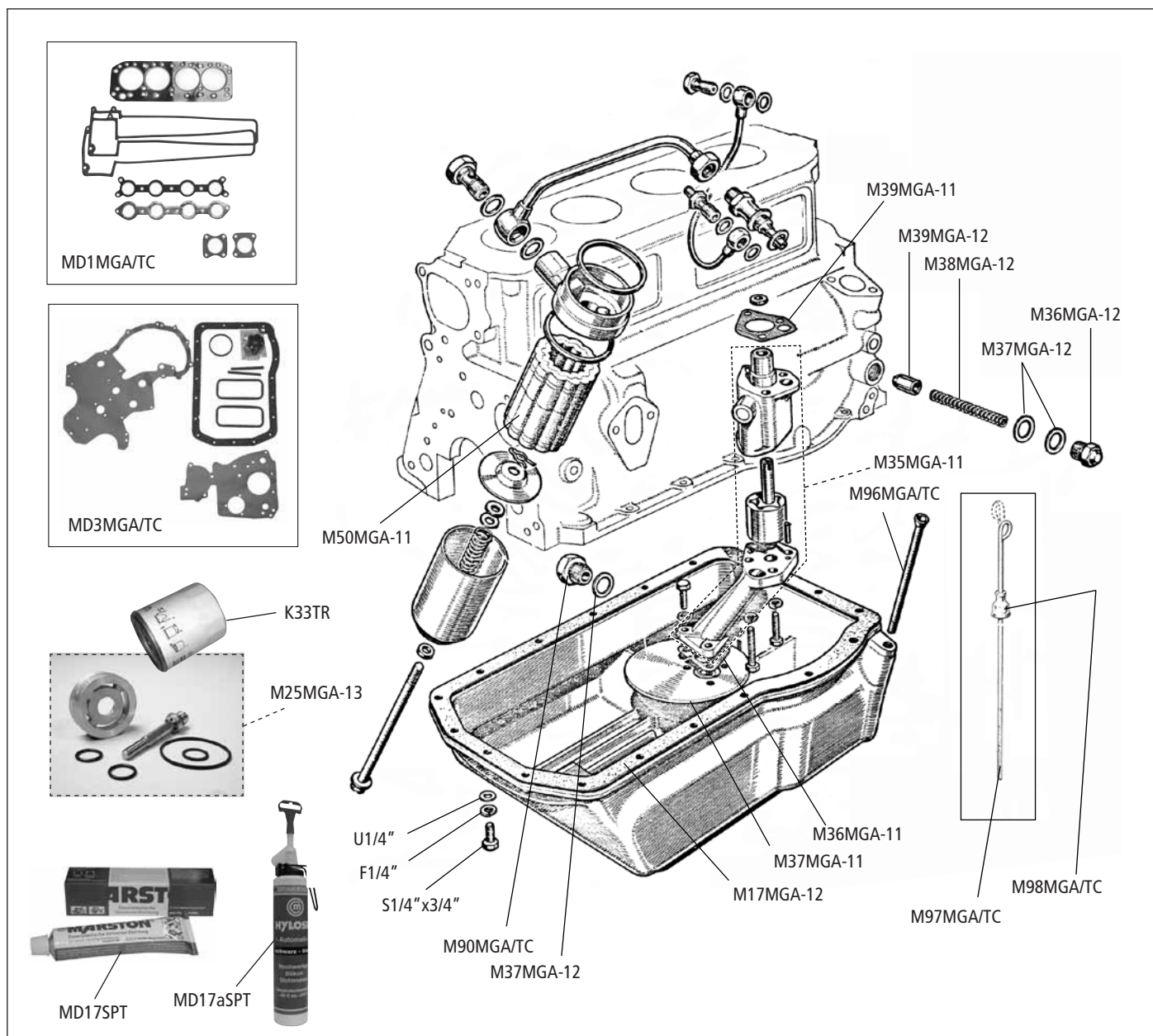

No.	Bezeichnung	Description	Anzahl/Qty.
V01MGA-14	Frischluftschlauch (Vergaser)	Fresh air hose carburettor intake	1
V02MGA-14	Halteklammer Frischluftschlauch	Clip retaining air hose	1
A25MGA-14	Mutter Auspuff Krümmer	Nut exhaust manifold	6
A29MGA-14	Dichtring Apuffrohr	Packing ring exhaust pipe	2
A30MGA-14	Stehbolzen Auspuff-Krümmer	Stud exhaust manifold to pipe	6
A32MGA-14	Mutter UNF 3/8" UNF Messing „	Nut 3/8" UNF brass	6
ZK59MGA/TC	Ansaugkrümmerdichtung	Gasket	1
ZK72MGA/TC	Krümmerdichtung	Gasket exhaust manifold	1
V75KNHS6	K+N Sportluftfilter	Sport air filter "KN"	2
V84MGA/TC	Original-Luftfilter	Original air filter	2
V84ATRH6	Chromluftfilter	Air filter, chrome	2
V83TRH6	Dichtung Ansaugkrümmer SU	Gasket 4 stud carburettor	2
V92TRH6	Luftfilterdichtung	Gasket, air filter to carburettor	4

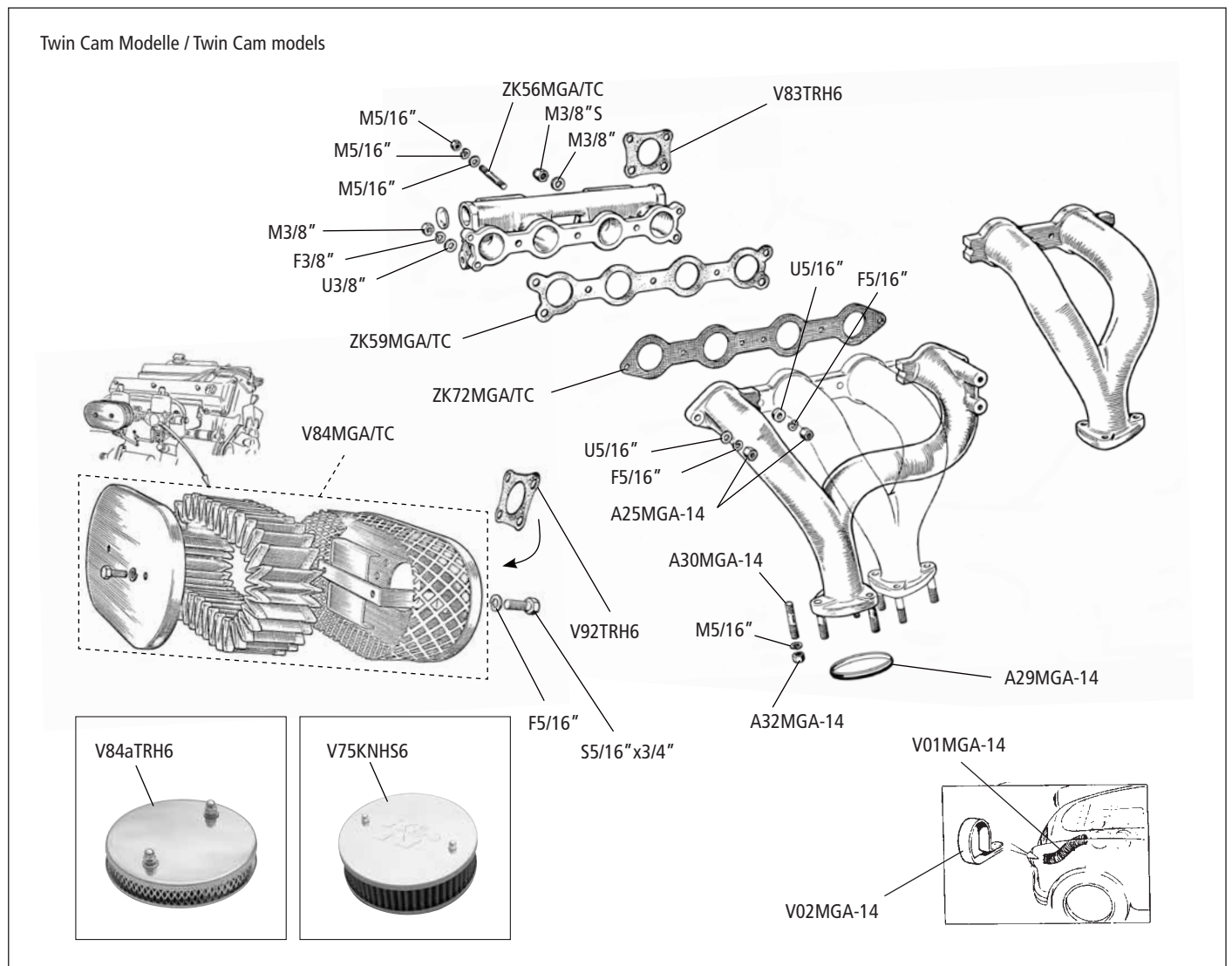

Hinweis 

Note:

Anmerkung zu M25MGA-13:
Dieser Umrüstsatz auf eine Einweg-Ölfilterpatrone macht den regelmäßigen Ölwechsel zu einer sauberen, einfachen Angelegenheit.

Note to no. M25MGA-13:
The use of a „Spin-on“-oil filter will make routine oil changing amuch cleaner and easier operation.

No.	Bezeichnung	Description	Anzahl/Qty.
	Luftfilter	Air Filter	
V01MGA-14	Frischlufschlauch (Vergaser)	Fresh air hose carburettor intake	1
V02MGA-14	Halteklammer Frischlufschlauch	Clip retaining air hose	1
V03MGA-14	Original-Luftfilter vorne	Original air filter front	1
V04MGA-14	Original-Luftfilter hinten	Original air filter rear	1
V06MGA-16	Dichtung Einlaßkrümmer/Vergaser	Gasket inlet manifold/carburettor	6
V10MGA-14	Hitzeschild	Heatshield	1
V13MGA-14	Entlüftungsschlauch	Breather hose	1
V14MGA-14	Halter Gaszugfeder	Bracket throttle spring	1
V15MGA-14	Stehbolzen Halter Gaszug	Stud inlet manifold	1
V51MGA-14	Satz Filzunterlagen	Felt pad set air filter	1
V73HS4	Dichtung Luftfilter	Gasket air filter	2
V75KNHS4	K+N-Sportluftfilter	K+N sport filter	2
V75AHS4	Chrom Sportluftfilter	Chrome air filter	2
V82GT6	Distanzblock Vergaser/Einlaßkrümmer	Insulating block carburettor/inlet manifold	2
S5/16"X3/4"	Befestigungsschraube Luftfilter/Vergaser	Setscrew air filter/carburettor	4

	Auspuffanlagen	Stainless Steel Exhaust Systems	
ZK06MGA-08	Stehbolzen Auspuffkrümmer „lang“ innen	Stud exhaust manifold inner „long“	4
ZK05MGA-08	Stehbolzen Auspuffkrümmer „kurz“ außen	Stud exhaust manifold outer „short“	2
EM07MGA-50	Schild Zündfolge Ansaugstutzen 1500	Plate brass firing order 1500	1
EM08MGA-50	Schild Zündfolge Ansaugstutzen 1600 + 1600 MK2	Plate brass firing order 1600 + 1600 MK2	1
A19MGA-14	Stehbolzen	Stud carburettor/inlet manifold	4
A21MGA-14	Unterlegscheibe	Manifold yoke	4
A25MGA-14	Mutter Auspuffkrümmer	Nut exhaust manifold	6
A27MGA-14	Auspuffkrümmer	Exhaust manifold	1
A29MGA-14	Dichtring Auspuffrohr	Packing ring exhaust pipe	1
A30MGA-14	Stehbolzen	Stud exhaust manifold to pipe	3
M3/8"	Mutter Auspuffkrümmer/Rohr	Nut exhaust manifold	3
A32MGA-14	Messingmutter Auspuffkrümmer/Rohr	Brass nut exhaust manifold	3
A34MGA	Hosenrohr	Front pipe	1
A35MGA	Mittleres Rohr	Coupling pipe	1
A36MGA	Endschalldämpfer	Rear Silencer	1
A37MGA-14	Befestigungs-Satz Mitte	Intermediate exhaust mounting kit	1
ZK38MGA-08	Auspuffkrümmer-Dichtung	Exhaust manifold gasket	1
A38MGA-14	Auspuffhalter Mitte	Intermediate exhaust mounting	1
S5/16"X23/4"	Bolzen Auspuffhalter Mitte	Bolt exhaust mounting	1
A41MGA-14	Befestigungsgummi hinten	Exhaust mounting rubber rear	1
S1/4x2 3/4" UNF	Bolzen	Bolt	1
A45MGA-14	Auspuffschelle (Original, ohne Bolzen)	Exhaust manifold clamp (original type)	1
A50MGA	Hosenrohr (Twin Cam)	Front pipe (Twin Cam)	1
A51MGA	Mittleres Rohr (Twin Cam)	Coupling pipe (Twin Cam)	1
A52MGA	Endschalldämpfer (Twin Cam)	Rear Silencer (Twin Cam)	1
A53MGA-14	Satz Buchse/Gehäuse mittlere Auspuffhalterung (A54MGA-14 + 2x A56MGA-14)	Bush/housing kit exhaust mounting intermediate (A54MGA-14 + 2x A56MGA-14)	1 1
A54MGA-14	Gehäuse mittlere Auspuffhalterung	Housing bracket exhaust mounting intermediate	1
A55MGA-14	Befestigungs-Streifen „lang“	Exhaust strap „long“	2
A56MGA-14	Buchse Auspuffaufhängung	Bush exhaust mounting	1
A57MGA-14	Befestigungs-Streifen „kurz“	Exhaust strap „short“	1
A58MGA	Edelstahl Fächerkrümmer außen und innen *)	Stainless exhaust manifold outer and inner *)	1
A59MGA	Sportauspuffanlage ab Fächerkrümmer/Hosenrohr	Sports exhaust behind manifold/front pipe	1
A514	Auspuffschelle 48 mm	Exhaust u-bolt 48 mm	A/R

*) ohne Abb.

*) w/o illustration

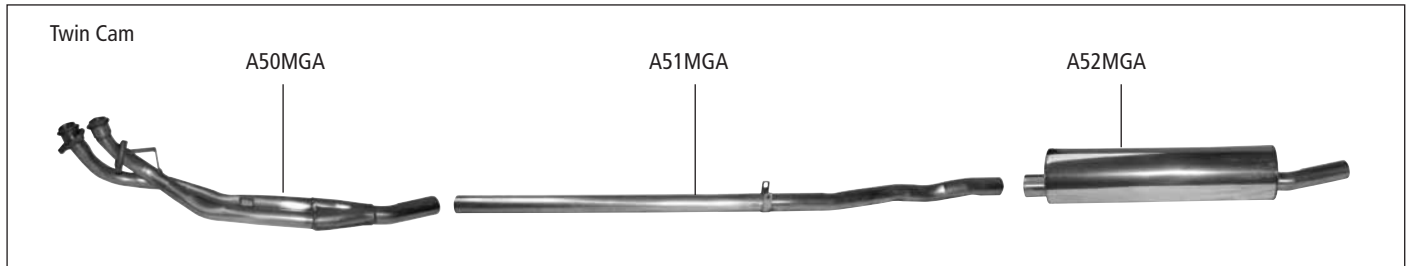
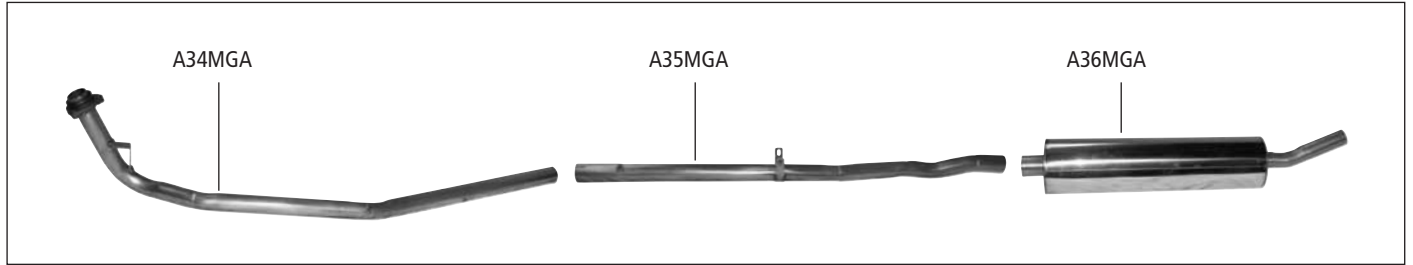
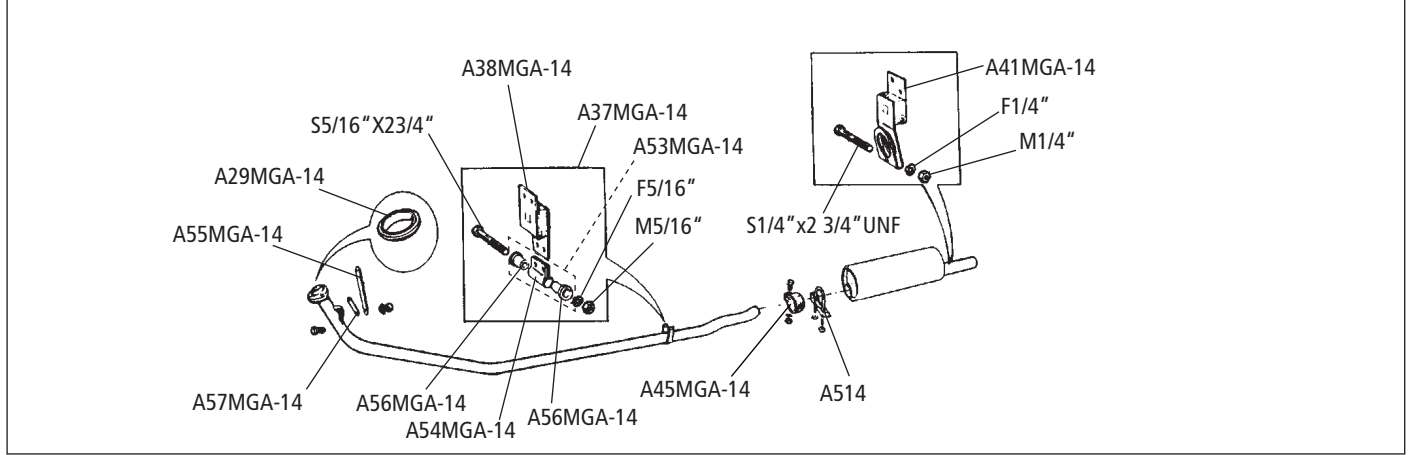
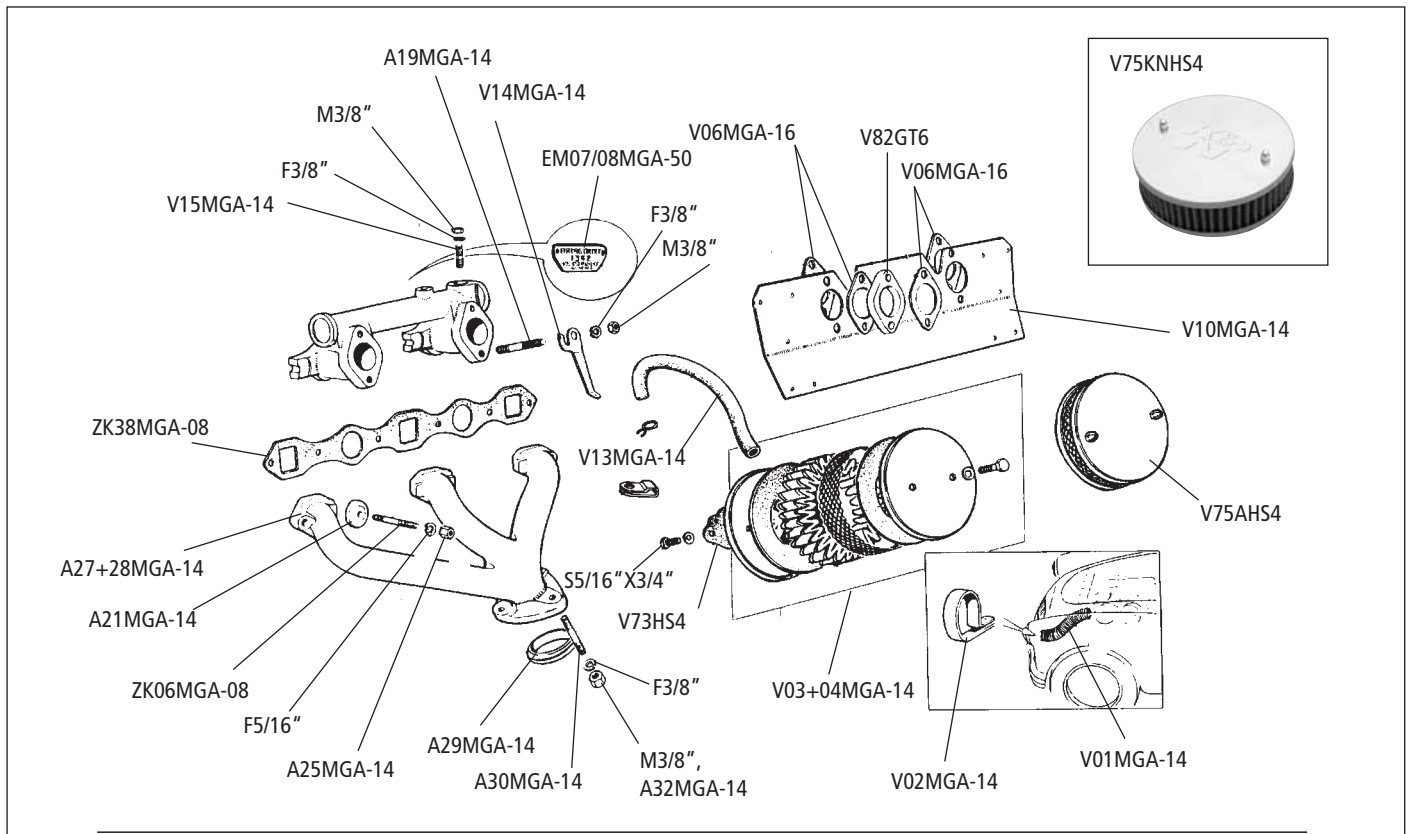

No.	Bezeichnung	Description	Anzahl/Qty.
V1MGA-H4	AT-Vergaseranlage H4 (2 Stück)	Carburettor H4, exchange (2 pieces)	1
V1MGA-H6	AT-Vergaseranlage H6 Twin Cam (2 Stück)	Carburettor H6, exchange, Twin Cam (2 pieces)	1
V01MGA-16	Vergaserüberholsatz 1500 (1 Vergaser)	Carburettor repair kit 1500 (1 carburettor)	1
V02MGA-16	Vergaserüberholsatz 1600 (2 Vergaser)	Carburettor repair kit 1600 (2 carburettor)	1
V1HS	Schraube	Screw	6
M2BA	Mutter	Nut	2
V3TRH4	Drosselklappenwelle	Throttle spindle	2
V04MGA-16	Lagersatz + Dichtungen Düsenstock	Jet bearing/gasket kit	2
V5TRHS6	Schraube Drosselklappe	Screw butterfly	4
V06MGA-16	Dichtung Einlaßkrümmer/Vergaser	Gasket inlet manifold/carburettor	6
V6HS	Schwimmernadelventil	Needle + seat	2
V6TR	Anschlußkupplung Vergaserwelle	Throttle spindle coupling	2
V09MGA-16	Lagergummi Schwimmerkammer	Grommet float chamber	4
V10TR	Madenschraube Düsennadel	Screw, needle locking	2
V12MGA	Betätigungshebel Schwimmer	Float lever	2
V15MGA-16	Dichtscheibe Schwimmerdeckel-/Überlaufleitung	Fibre washer float chamber lid/overflow pipe	2
WZ16MGA-53	Gemisch-Einstellschlüssel	Mixture adjusting tool	1
V22MGA-16	Rückholfeder Chokebetätigungshebel	Choke return spring	2
V27MGA-16	Chokebetätigungshebel vorne	Choke lever front	1
V28MGA-16	Chokebetätigungshebel hinten	Choke lever rear	1
V28TRH6	Vergaser-Dämpferkolben 1500 (Messing)	Carburettor damper 1500 (brass)	2
V29HS	Vergaser-Dämpferkolben 1600 + MK2 (Plastik)	Carburettor damper 1600 + MK2 (plastic)	2
V29MGA-16	Vergaserhebel gerade	Throttle lever straight	1
V29aMGA-16	Vergaserhebel abgewinkelt	Throttle lever angled	1
V30TRH6	Vergaserdämpfer-Feder (rot)	Carburettor piston spring (red)	2
V32MGA-16	Gaszug - o. Abb.	Throttle cable - w/o illustr.	1
V33MGA-16	Sockel Gaszug - o. Abb.	Guide throttle cable - w/o illustr.	1
V34MGA-16	Rückholfeder Gaspedal - o. Abb.	Throttle return spring - w/o illustr.	1
V35MGA-16	Rückholfeder Drosselklappe - o. Abb.	Return spring, throttle disc - w/o illustr.	1
V36MGA-16	Halter Rückholfeder	Spring tag	1
V37MGA-16	Befestigung Gaszug	Throttle link pin	2
V38MGA-16	Halter Gaszug/Chokezug auf Ansaugbrücke	Bracket throttle cable/choke cable on inlet manifold	1
V38ATR	Büchse Drosselklappenwelle	Bush, carburettor spindle	4
V39TRH4	Düsenstock	Carburettor jet	2
V40HS4	Drosselklappe	Throttle disc	2
V42MGA-16	Gaszug-Führung an V38MGA-16	Throttle cable trunnion on part no. V38MGA-16	1
V43MGA-16	Chokezug-Führung an V38MGA-16	Choke cable trunnion on part no. V38MGA-16	1
V45MGA-16	Hebestiftsatz Kolben	Lifting pin kit	2
V47MGA-16	Hohlschraube und Befestigungssatz	Pillar union and fitting kit	2
V48MGA-16	Scheibe Aluminium	Washer aluminium on centre nut	2
V48TRH6	Schwimmer	Float	2
V49MGA-16	Halteschraube Deckel Schwimmerkammer	Centre nut float chamber lid	2
E49MGA-35	Chokezug Linkslenker	Choke cable lhd	1
E50MGA-35	Chokezug Rechtslenker	Choke cable rhd	1
V50MGA-16	Feder Gemischeinstellmutter	Spring mixture screw	2
V51MGA-16	Dichtscheibe Aluminium	Washer aluminium	2
V52MGA-16	Lagerstift Schwimmer	Pivot pin float	2
V53MGA-16	Feder Düse	Spring jet	2
V54MGA-16	Hohlschraube Schwimmerkammer	Banjo bolt float chamber	2
V54TRH6	Dichtung Schwimmerkammer/Betätigungshebel	Gasket float chamber/lid	2
V55MGA-16	Scheibe	Washer	2
V56MGA-16	Korkscheibe	Cork seal	2
V57MGA-16	Messingscheibe	Brass washer	4
V58MGA-16	Kork Dichtring	Cork gland washer	4
V59MGA-16	Einstellmutter Gemisch	Mixture adjusting nut	2
V60MGA-16	Kupferscheibe Düsenstock oben	Copper washer top jet	2
V61MGA-16	Lagerstift	Clevis pin	6
V62MGA-16	Schraube	Screw	2
V63MGA-16	Lager Düsenstock oben	Jet bearing upper	2
V64MGA-16	Lager Düsenstock unten	Jet bearing lower	2
V65MGA-16	Bolzen	Bolt	1
V66MGA-16	Anschluß Unterdruckleitung	Union vacuum connection	1
V67MGA-16	Rückholfeder Gasgestänge vorne	Spring throttle return front	1
V68MGA-16	Rückholfeder Gasgestänge hinten	Spring throttle return rear	1
V69MGA-16	Verbindungsbügel	Connecting lever	2

No.	Bezeichnung	Description	Anzahl/Qty.
V70MGA-16	Vergasernadel (bitte Bezeichnung angeben)	Needle (please refer specification of the needle)	2
V73HS4	Dichtung Luftfilter	Air filter gasket	2
V74MGA-16	Stift	Pin locking	2
M75aMGB	Fiberdichtscheibe	Washer (fibre)	2
V75MGA-16	Deckel Schwimmerkammer mit Hebel vorne	Float chamber lid with lever front	1
V76MGA-16	Deckel Schwimmerkammer mit Hebel hinten	Float chamber lid with lever rear	1
V77MGA-16	Mutter Einstellung	Nut adjusting link	2
V79MGA-16	Distanzrohr	Nut	2
V80MGA-16	Anschlag Gaspedal	Accelerator pedal stop	1
V82GT6	Distanzblock Vergaser/Einlaßkrümmer	Insulating block	2
V90TRH6	Vergaser-Dichtsatz (für H4 + H6 Vergaser)	Carburettor gasket pack (for H4 + H6 carburettors)	2
WZ75	Vergaser Synchro-Tester	Carburettor synchronizer	A/R
SU-VÖ	SU-Vergaseröl, 150 ml	Oil, SU carburettors, 150 ml	A/R

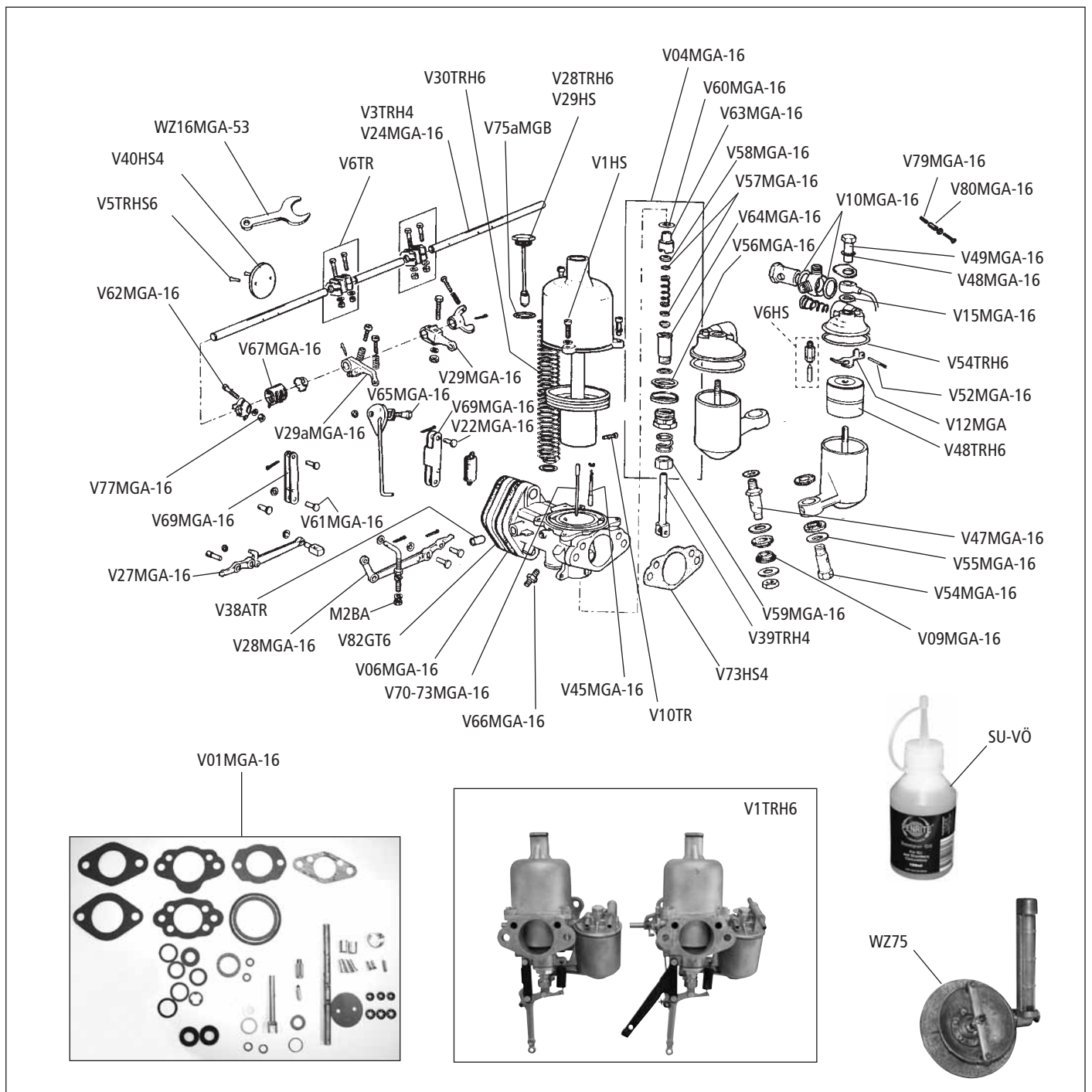

No.	Bezeichnung	Description	Anzahl/Qty.
Weber DCOE 40, DCOE 45			
V3TRW	Weber DCOE40 mit Düsenbestückung	Weber DCOE40 with Needles, Jets	1
V4TRW	Weber DCOE45 mit Düsenbestückung	Weber DCOE45 with Needles, Jets	1
V5TRWMGA40	Umrüstsatz MGA aufWeber DCOE40 - beinhaltet 1 Vergaser DCOE40 und 1x Ansaugstutzen	Conversion Kit MGA to Weber DCOE40 contains 1 carburettor DCOE40 and 1x inlet manifold	1
V5TRWMGA45	Umrüstsatz MGA aufWeber DCOE45 - beinhaltet 1 Vergaser DCOE45 und 1x Ansaugstutzen	Conversion Kit MGA to Weber DCOE45 contains 1 carburettor DCOE45 and 1x inlet manifold	1
V7TRW	K+N Luftfilter Bauhöhe 55 mm (Weber DCOE40)	Air Filter K&N, height 55 mm (Weber DCOE40)	1
V8TRW-...	Luftkorrekturdüse (bitte Größe angeben)	Air correction jet (please refer size)	2
V9ATRW	Luftfilterdichtung	Gasket air filter	1
V10TRW	Chromluftfilter für Weber DOCE40/45	Air Filter , chrome, Weber DCOE40/45	1
V10TRW-...	Mischrohr (bitte Größe angeben)	Emulgation tube (please refer size)	2
V11TRW-...	Leerlaufdüse (bitte Größe angeben)	Idle speed jet (please refer size)	2
V12TRW-...	Hauptdüse (bitte Größe angeben)	Main jet (please refer size)	2
V15TRW	Schwimmer	Float	1
V25TRW-...	Lufttrichter	Funnel pipe	2
V20TRW	Rückholfeder Drosselklappenwelle	Return spring throttle shaft	1
V72TRW-...	Pumpendüse (bitte Größe angeben)	Pump jet (please refer size)	A/R
V90TRW	Vergaserdichtsatz für Weber DCOE	Carburettor gasket set Weber DCOE	1
V91TRW	Vergaserreparatursatz Weber DCOE incl. Schwimmernadelventil	Rebuilt kit Weber DCOE including float needle jet	1
V100MGA	Ansaugstutzen für 1x Weber DCOE (MGA - nicht Twin Cam)	Inlet manifold, 1x Weber DCOE (MGA - not Twin Cam)	1
V115TRW	O- Ring mit Metalleinlage zwischen Weber- Vergaser und Ansaugstutzen	O- ring with metal insert between Weber carburetters and inlet manifold	2

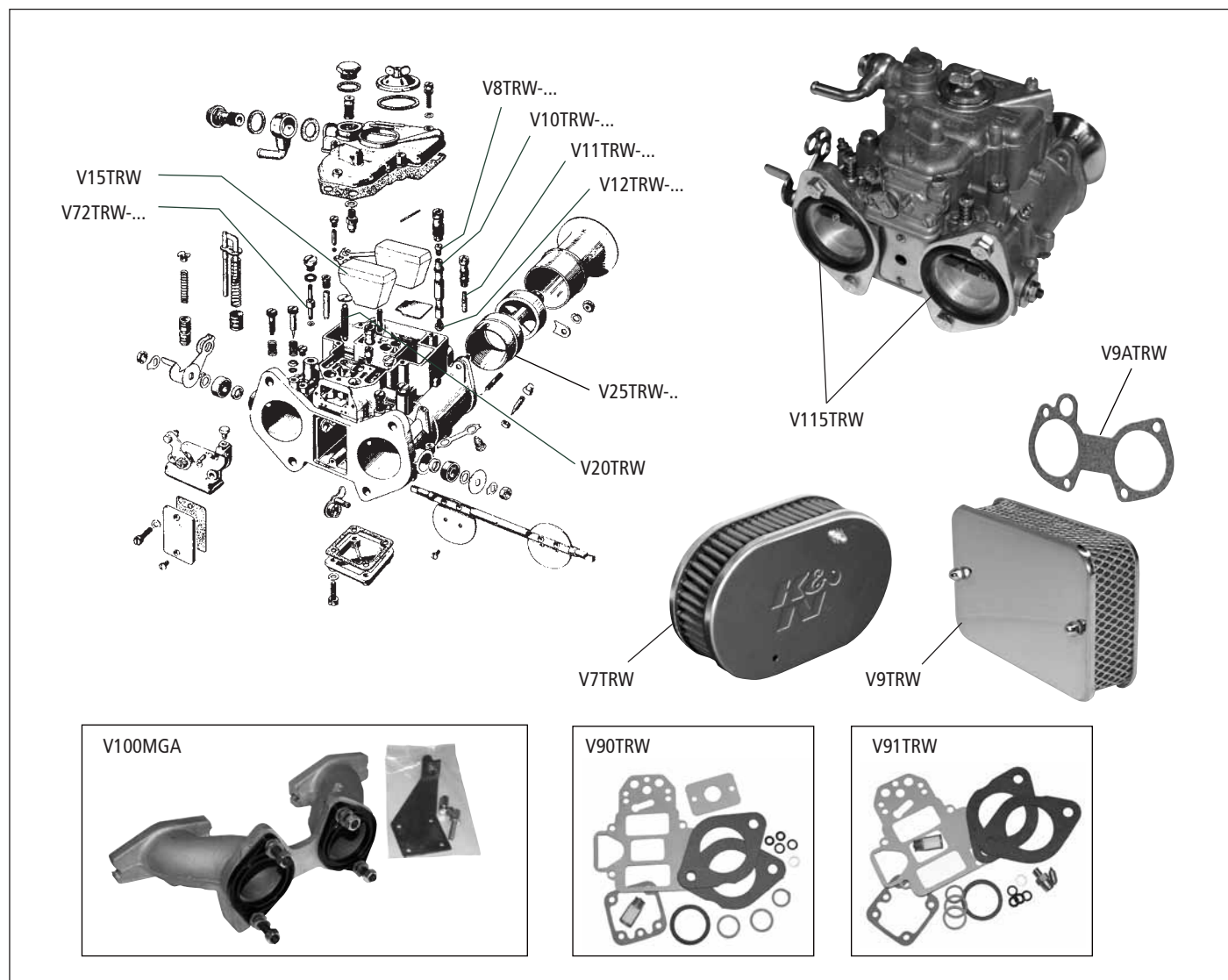

Classic Tuning für Straße, Rallye und Rennsport

Neben unserem umfangreichen Fahrzeugteile-Programm für den "normalen" Straßeneinsatz bieten wir auch Rennsport- und Tuningteile an bis hin zu leistungsgesteigerten Motoren für Wettbewerbszwecke.

Auf den folgenden Seiten finden Sie sportliche Zutaten, die auf 1800ccm-Motore ausgelegt sind. Setzen Sie sich bitte mit uns in Verbindung, wenn Sie die Leistung einer 1500 oder 1600-er Maschine steigern wollen!

Fragen Sie einfach nach – wir beraten Sie gerne!

Classic Tuning for Road, Rally & Racing

Apart from our standard parts for the "everyday"-use we offer a lots of competition parts for road, rally or racing. We can supply a wide range of high performance engine parts but also competition engines ready for your racing weekend.

The following parts are optimised for 1800ccm-engines. Tuning for 1500 and 1600ccm engines on demand – please feel free to contact us - we can help you!

Hinweis 
Note

Überrollbügel und -käfige, auch Sonderanfertigungen auf Anfrage!

Built to order rollcages and -arcs upon request!



Unser Tipp:

News und Termine für Motorsport-Interessierte auf unseren Webseiten:
www.bastuck.com

Our tip:

News and race terms on our websites:
www.bastuck.com



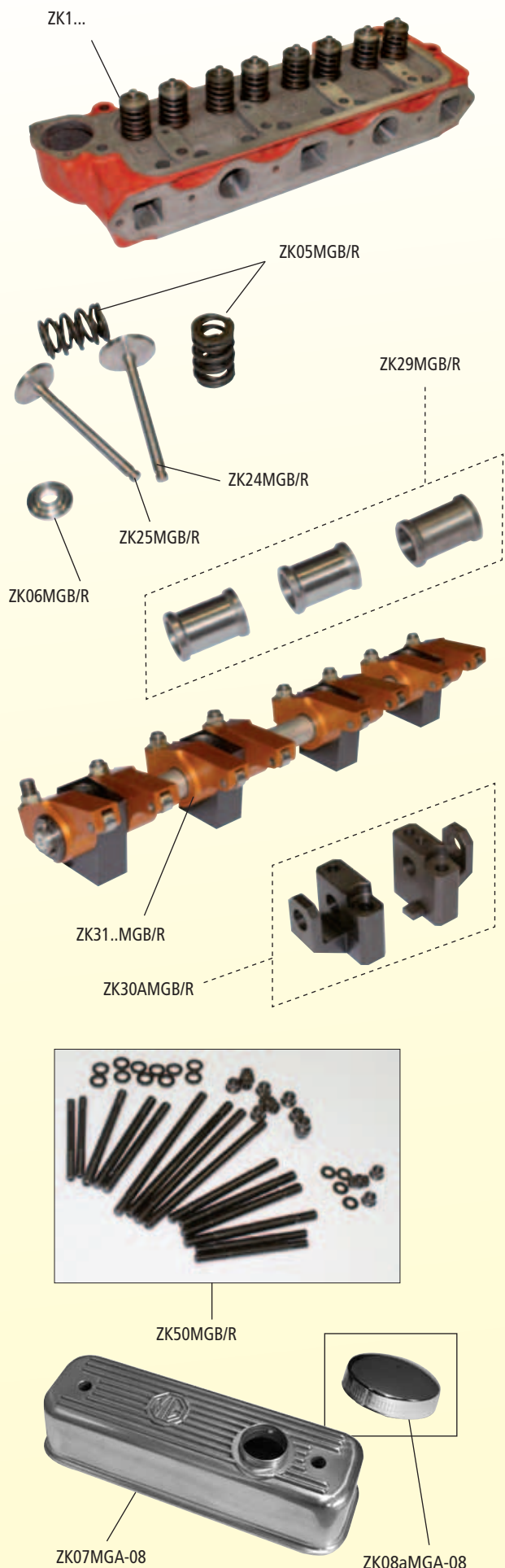

Rennsportzubehör

No.	Bezeichnung
T57...	Aluminium-Pedalaufgabe Satz (verschiedene Farben)
T98...	Textilklebeband (verschiedene Farben)
T120	Handfeuerlöscher OMP Eco Life, AFFF Gewicht 4,9 kg - Inhalt 2,64 kg
T150	Motorhaubenhalteset
T150A	Motorhaubenhalteset Aluminium
T151	Federhalter mit Haken für Kofferraumdeckel
T152	Hauptstromschalter 6-polig
T160B	Facet Benzinpumpe "Blue Top"
T160R	Facet Benzinpumpe "Red Top"
T160S	Facet Benzinpumpe "Silver Top"
T160-1/4	Anschluß 1/4NPT für T160B und T160R
T160-1/8	Anschluß 1/8NPT für T160S
T161	"Filter King" Druckregler incl. Benzinfilter
T845	Hitzeschutzband 50 mm, Rolle ca. 15 m
T847	Hitzeschutzband 25 mm, Rolle ca. 15 m
T4520/58	Fliegertankdeckel abschliessbar, Ø 58 mm, 6 Befestigungslöcher, für 2"-Anschluß
T4520/76	Fliegertankdeckel abschliessbar, Ø 76 mm, 8 Befestigungslöcher, für 2"-Anschluß
T4522	Schraubenset V2A für Tankdeckel T4520/58 und T4520/76 (8 Schrauben)

Zylinderkopf

ZK1MGB/R	AT-Zylinderkopf mit Kipphebelgalerie Ölbohrung in Reihe *)
ZK1AMGB/R	AT-Zylinderkopf mit Kipphebelgalerie Ölbohrung versetzt *)
ZK1MGB/FR	AT-Full Race Zylinderkopf wie ZK1MGB/R, aber für Rennfahrzeuge optimiert
ZK1AMGB/FR	AT-Full Race Zylinderkopf wie ZK1AMGB/R, aber für Rennfahrzeuge optimiert
ZK05MGB/R	Satz doppelte Ventildfedern für Nockenwelle über 7,5 mm Nockenhub
ZK06MGB/R	Passender Ventilteller für ZK05MGB/R-Ventildfedern
ZK07MGA-08	Aluminium Ventideckel
ZK27MGA-09	Satz Bronze Ventildführungen, strömungsgünstig und mit besseren Notlaufeigenschaften
ZK24MGB/R	Strömungsgünstiges Einlaßventil Ø 43 mm (1.70")
ZK25MGB/R	Strömungsgünstiges Auslaßventil Ø 35 mm (1.45")
ZK29MGB/R	Satz Kipphebelstanzhülsen (ersetzt Original Federn)
ZK30MGB/R	Paar verstärkte, äußere Kipphebelböcke (für Zyl.-köpfe mit "in line" befindlicher Ölbohrung) Schema A
ZK30AMGB/R	Paar verstärkte, äußere Kipphebelböcke (für Zyl.-köpfe mit "versetzter" Ölbohrung) Schema B
ZK31MGB/R	Rollengelagerte Kipphebelwelle (Schema A)
ZK31AMGB/R	Rollengelagerte Kipphebelwelle (Schema B)
ZK50MGB/R	Satz hochfeste Zylinderkopf-Stehbolzen + Muttern
ZK65SPTR	Zylinderkopfmutter hochfest
ZK66SPTR	Unterlegscheibe hochfest für ZK65SPTR

Spezial-Dichtungen:

M26MGB/1950	Zylinderkopfdichtung für 1950 ccm-Motoren
ZK38MGA/R	Einlaß/Auslaßdichtung für Zylinderköpfe mit vergrößerten Kanälen

Ölbohrung / Oil feed scheme

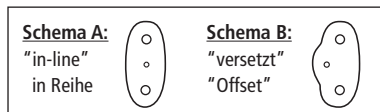

* Tuning für 1500 + 1600-er Motoren - bitte anfragen!
feel free to ask for tuning 1500 + 1600 ccm engines

Racing Accessories

Description	Anzahl/Qty.
Aluminium pedal plates, various colours	1
Textile tape, various colours	A/R
Fire extinguisher OMP Eco Life, AFFF	1
Weight: 4,9 kg - Content: 2,64 kg	
Bonnet holders, set	1
Aluminium bonnet holders, set	1
Luggage boot holders, spring and hook	1
Main current switch, 6-pole	1
Fuel pump "Blue Top"	1
Fuel pump "Red Top"	1
Fuel pump "Silver Top"	1
Connection 1/4NPT for T160B and T160R	2
Connection 1/8NPT for T160S	2
Fuel pressure regulator "Filter King" with fuel filter	1
Heat shield tape 50 mm, Reel ca. 15 m	A/R
Heat shield tape 25 mm, Reel ca. 15 m	A/R
Aviation tank cap, lockable, Ø 58 mm, 6 mounting holes, 2" connector	1
Aviation tank cap, lockable, Ø 76 mm, 8 mounting holes, 2" connector	1
Screw set, inox, for tank caps T4520/58 and T4520/76 (8 screws)	1

Cylinder Head

Exchange cylinder head rocker gallery with In-Line oil feed *)	1
Exchange cylinder head rocker gallery with Offset oil feed *)	1
Exchange cylinder head Full Race - like described in ZK1MGB/R, dedicated for racing	1
Exchange cylinder head Full Race - like described in ZK1AMGB/R, dedicated for racing	1
Fast Road/Sport valve springs set, camshaft with cam lift 7,5 mm and more	1
Collar for valve spring no. ZK05MGB/R	8
Aluminium rocker arm cover	1
Bronze valve guides set	1
Intake valve, air jet optimized, Ø 43 mm (1.70")	4
Exhaust valve, air jet optimized, Ø 35 mm (1.45")	4
Spacer set (replaces original spacer)	1
Uprated outer pedestal (cylinder head with "In-Line" oil feed) SHEME A	1
Uprated outer pedestal (cylinder head with "Offset" oil feed) SHEME B	1
Roller rocket set, "In-Line" oil feed (Scheme A)	1
Roller rocket set, "Offset" oil feed (Scheme B)	1
Uprated engine stud and nut kit	1
Uprated cylinder head nut	11
Uprated washer to no. ZK65SPTR	11
Special Gaskets:	
Gasket cylinder head for 1950 cc	1
Gasket Inlet/Outlet for air flow revised cylinder heads with increased ports	1

*) mit größeren Ventilen, überarbeitetem Brennraum, überarbeiteten Einlaß/Auslaßkanälen, neuen Ventilführungen und verstärkten Ventildfedern

*) equipped with: bigger sized valves, revised ports and chambers, new valve guides and double valve springs

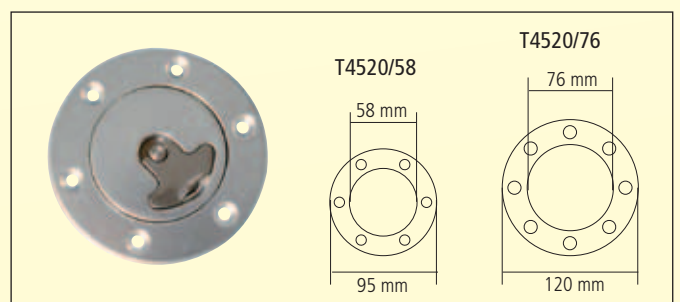
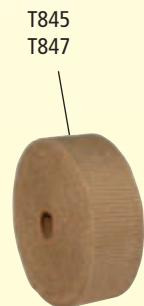
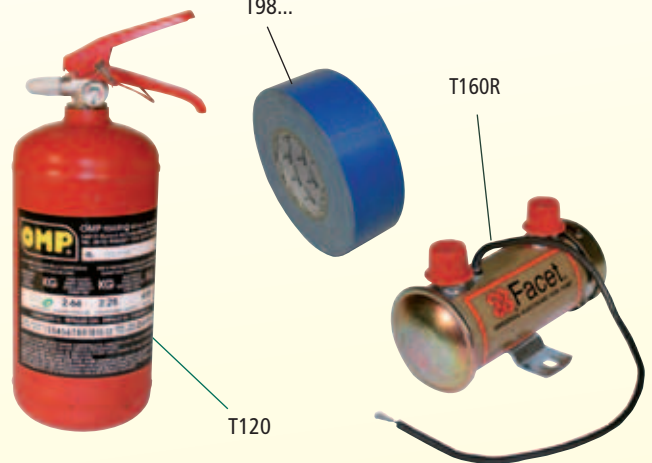
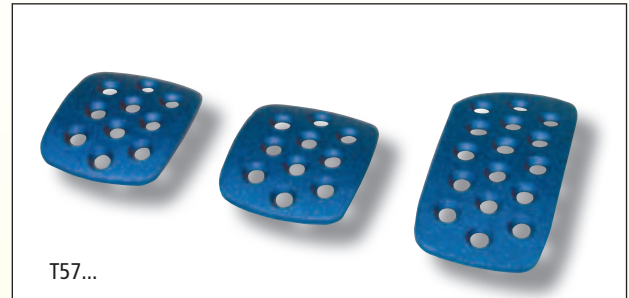

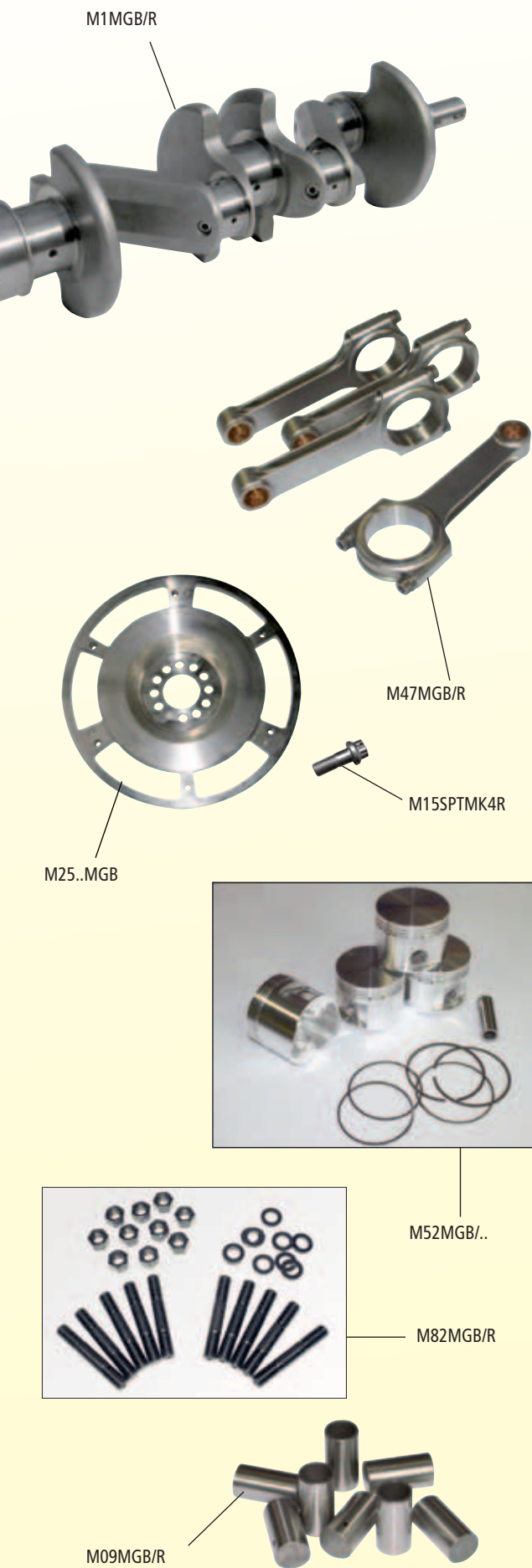

No.	Bezeichnung
M1MGB/R	Stahlkurbelwelle 5x Hauptlager
M09MGB/R	Erleichterter Stößelbecher
M10MGB/R	Leichte Rohrstoßelstange
M15MGA/R	Überarbeiteter Verteiler-Ölpumpenantrieb mit Spezial Bronze-Zahnrad
M15AMGA/R	Bronze Zahnrad separat für M15MGA/R
M15SPTMK4R	Hochfeste Befestigungsschraube für Schwungscheibe
M25aMGB	Leichte Stahlschwungscheibe für Motoren mit 3x Hauptlagern (1962-64)
M25bMGB	Leichte Stahlschwungscheibe für Motoren mit 5x Hauptlagern, 3-Synchro-Getriebe (1964-67)
M25cMGB	Leichte Stahlschwungscheibe für Motoren mit 5x Hauptlagern, 4-Synchro-Getriebe (1967-80)
M46MGA/R	Einstellbares Kettenrad Nockenwelle für doppelte Steuerkette
M47MGB/R	Motorsport-Pleuel, sehr leicht und unverwüchlich
M52MGB/STDR	Satz leichte, geschmiedete Kolben (1800 ccm)
M52MGB/1950R	Satz leichte, geschmiedete Kolben (1950 ccm)
M52MGB/1950	Satz Kolben (1950 ccm)
M82MGB/R	Stehbolzen-Satz Hauptlagerdeckel hochfest
M103	Gradscheibe für Nockenwellen-Einstellung
M100MGB	Aluminium Ölwanne für 5x gelagerte Motoren
M110MGBA	Hintere Motorenplatte Alu für 5x gelagerte Motoren
M110AMGBA	Hintere Motorenplatte Alu für 3x gelagerte Motoren

Nockenwellen

M280MGB/R	280° Sportnockenwelle 37/67 73/27 Steuerzeiten, 7.15 mm Nockenhub. Beste Nockenwelle für die Straße
M290MGB/R	290° Sportnockenwelle 42/68 78/32 Steuerzeiten, 7.84 mm Nockenhub. Geeignet für gut getunte Straßen- und Rallyemotoren
M300MGB/R	300° Sportnockenwelle 47/73 83/37 Steuerzeiten, 8.22 mm Nockenhub. Nockenwelle geeignet für Rundstrecke
M310MGB/R	310° Sportnockenwelle 52/68 88/42 Steuerzeiten, 8.6 mm Nockenhub. Die ultimative Rundstrecken-Nockenwelle

Tilton Sport-Kupplungen

C2SPTRACE	Tilton Kupplungsautomat 7 1/4"
C2ASPTRACE	Anpressring für Tilton Kupplungsautomat einzeln
C2ASPTRACE205	Federsatz für Tilton Kupplungsautomat einzeln
C3Tilton1"x23	Kupplungsscheibe Ø 7 1/4" mit 1" x 23 Zähne Aufnahme für Kupplungsautomat C2SPTRACE
C3MGBRACE	Sport Kupplungsscheibe (ungefedert) mit Carbon-Sintermetallbelag für Serien Kupplungsautomaten

* Tuning für 1500 + 1600-er Motoren - bitte anfragen!
feel free to ask for tuning 1500 + 1600 ccm engines

Description	Anzahl/Qty.
Steel crankshaft 5x bearing	1
Lightened cam follower	8
Lightweight push rod	8
Reconditioned oil pump drive with special bronze gear	1
Bronze gear, separate for oil pump drive no. M15MGA/R	1
Flywheel screw, reinforced	1
Lightweight steel flywheel, 3x bearing engines (1962-64)	1
Lightweight steel flywheel, 5x bearing engines, 3-synchro gearbox (1964-67)	1
Lightweight steel flywheel, 5x bearing engines, 4-synchro gearbox (1967-80)	1
Adjustable camshaft gear, for duplex timing chain	1
Connecting rod competition	4
Piston set, lightweight and forged (1800 cc)	1
Piston set, lightweight and forged (1950 cc)	1
Piston set (1950 cc)	1
Uprated stud main cap, set	1
Cam timing degree disc	1
Alloy oil sump, 5x bearing engine	1
Alloy backplate, 5x bearing engine	1
Alloy backplate, 3x bearing engine	1

Camshaft

280° Sports camshaft, timings: 37/67 73/27, tappet travel 7.15 mm. Best camshaft for road use	1
290° Sports camshaft, timings: 42/68 78/32, tappet travel 7.84 mm. For good optimized road and rallye engines	1
300° Sports camshaft, timings: 47/73 83/37, tappet travel 8.22 mm. Camshaft for round courses	1
310° Sports camshaft, timings: 52/68 88/42, tappet travel 8.6 mm. Ultimate camshaft for round courses	1

Tilton Sport Clutches

Tilton clutch cover 7 1/4"	1
Release bearing for Tilton clutch cover	1
Spring set for Tilton clutch cover	1
Clutch plate Ø 7 1/4" with 1" x 23 spline for fitting clutch cover C2SPTRACE	1
Sport clutch plate sintered for serial clutch cover	1



No.	Bezeichnung	Description	Anzahl/Qty.
K01MGA-15	Wasserkühler	Radiator	1
K4SPT	Wasserthermostat 74 Grad	Water thermostat 74 °C	1
K4ASPT	Wasserthermostat 82 Grad	Water thermostat 82 °C	1
K6TR3	Kühlerdeckel	Radiator cap	1
K06MGA-15	Set Kühler-Unterlagen	Packing set radiator	1
K07MGA-15	Drahtschelle	Wire clip	A/R
K08MGA-15	Kühlerschlauch oben/unten	Radiator hose top/bottom	2
K09MGA-15	Knie-Rohr Kühlerschlauch	Water elbow radiator hoses	1
K9TR6	Kühlerschlauch Bypass	Bypass hose	1
K10MGA-15	Anschlusssteil Heizschlauch	Union (used if heater is fitted)	1
K11MGA-15	Verschlussstopfen (bei fehlender Heizung)	Plug (used if heater is not fitted)	1
K12MGA-15	Dichtscheibe	Sealing washer copper	1
K15MGA-15	Wasserpumpe	Water pump	1
K16MGA-15	Dichtung Wasserpumpe	Gasket water pump	1
K17MGA-15	Keilriemenscheibe Wasserpumpe	Pulley	1
K18MGA-15	Keilriemen	Fan belt	1
K19MGA-15	Lüfterflügel	Fan blades	1
11/4"X3/4"	Schraube Lüfterflügel	Setscrew	4
K21MGA-15	Deckel Thermostatgehäuse	Cover thermostat housing	1
K22MGA-15	Dichtung Thermostatgehäuse	Thermostat gasket housing	1
ZK24MGA-08	Stehbolzen Thermostatgehäuse	tud cover thermostat housing	3
K28MGB-12	Überlaufschlauch Kühler	Radiator overflow hose	1
K40TR4	Wasserablaßhahn	Water tap engine drain	1
SR64	Kupferdichtung Wasserhahn	Copper washer water tap	1

Kühlanlage Twin Cam**Cooling System Twin Cam**

K1MGA/TC	AT-Kühler MGA Twin Cam	Radiator exchange, MGA Twin Cam	1
K4SPT	Wasser-Thermostat 74 °C	Thermostat 74 °C	1
K4ASPT	Wasser-Thermostat 82 °C	Thermostat 82 °C	1
K6TR3	Kühler-Deckel 7 PSI	Radiator cap 7psi	1
K09MGA/TC	Kühlerschlauch unten	Radiator hose, lower	1
K9SPT	Schlauch-Schelle 1/2" - 3/4"	Hoseclip 1/2" - 3/4"	A/R
K10MGA/TC	Kühlerschlauch oben	Radiator hose, upper	1
K10SPT	Schlauchschelle 30-35mm	Wire clip1 30-35mm	A/R
K12MGA/TC	Wasserpumpe	Water pump	1
SR14	Linsenkopfschraube 3/16"x3/4"	Screw 3/16"x3/4"	6
K15MGA/TC	Schlauch zum Behälter	Hose to tank	4
K19MGA-15	Lüfterflügel	Fan blades	1
K21MGA/TC	Behälter Kühlwasser	Header tank	1
M22BTR4R	Keilriemen MGA / Twin Cam	Fan belt MGA / Twin Cam	1
K23MGA/TC	Dichtung Kühlerdeckel	Gasket radiator cap	1
K40TR4	Wasserablasshahn Motor (08051-11)	Water tap engine drain	1
K54MGA/TC	Halter für Behälter Kühlwasser	Header tank bracket	1
SR64	Dichtring	Washer fibre	1
K69MGA/TC	Dichtung Wasserpumpengehäuse	Gasket water pump housing	1
K90MGA/TC	Riemenscheibe Wasserpumpe	Water pump pulley	1
K111MGA/TC	Wasserrohr Eingangsbogen	Inlet elbow	1
K112MGA/TC	Dichtung Wasserrohr	Gasket water pipe	1
K117MGA/TC	Schlauch an Wasserpumpengehäuse	Hose to water pump housing	1
K119MGA/TC	Wasserrohr Ausgang Wasserpumpe	Outlet pipe	1
K122MGA/TC	Thermostatgehäuse	Thermostat housing	1
K123MGA/TC	Deckel Thermostatgehäuse	Cover thermostat housing	1
K124MGA/TC	Thermostatgehäusedichtung	Gasket thermostat housing	1
K130MGA/TC	Schlauch	Hose	1
K138MGA/TC	Bypass Rohr	Bypass pipe	1
K140MGA/TC	Schlauch	Hose	1

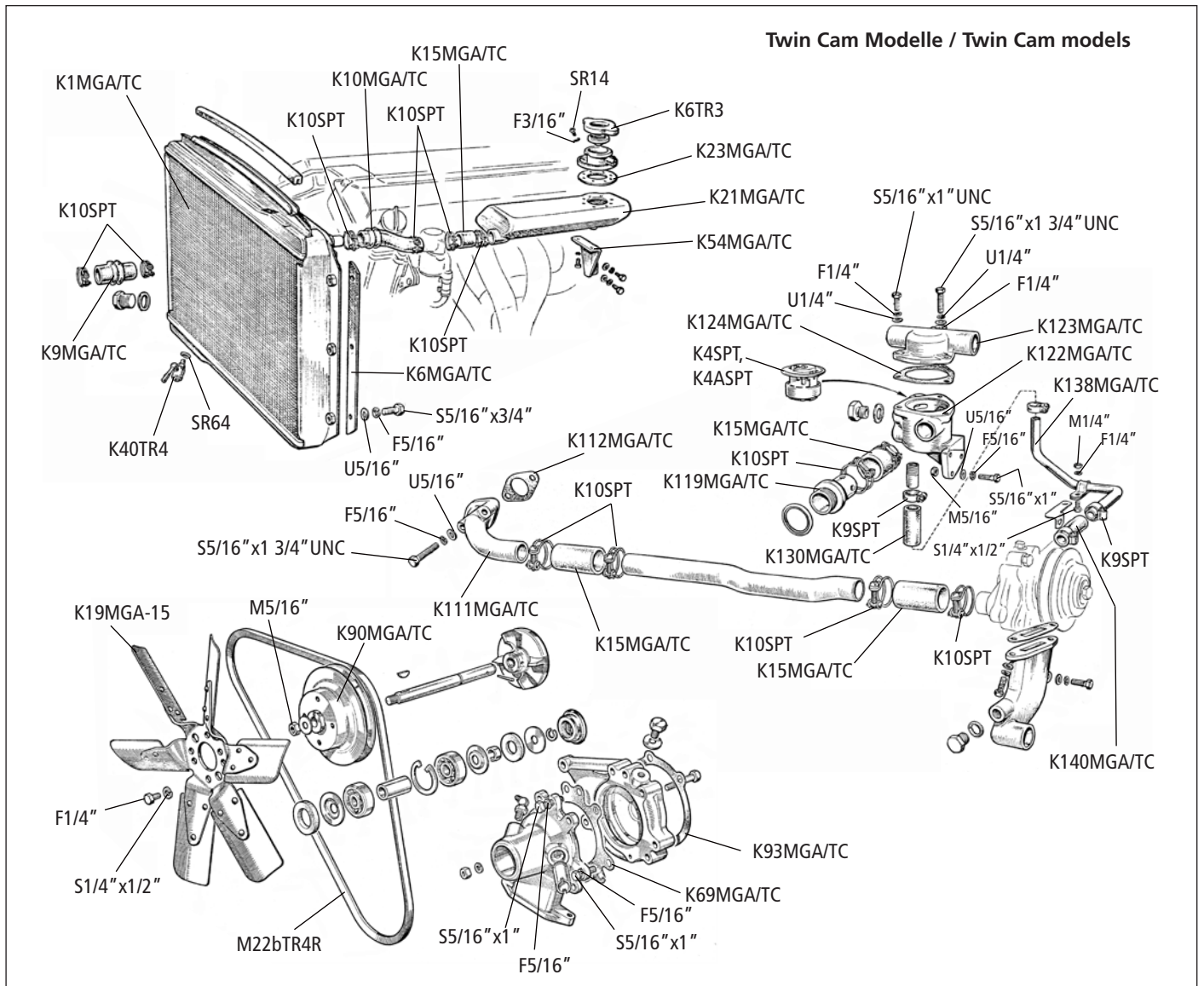
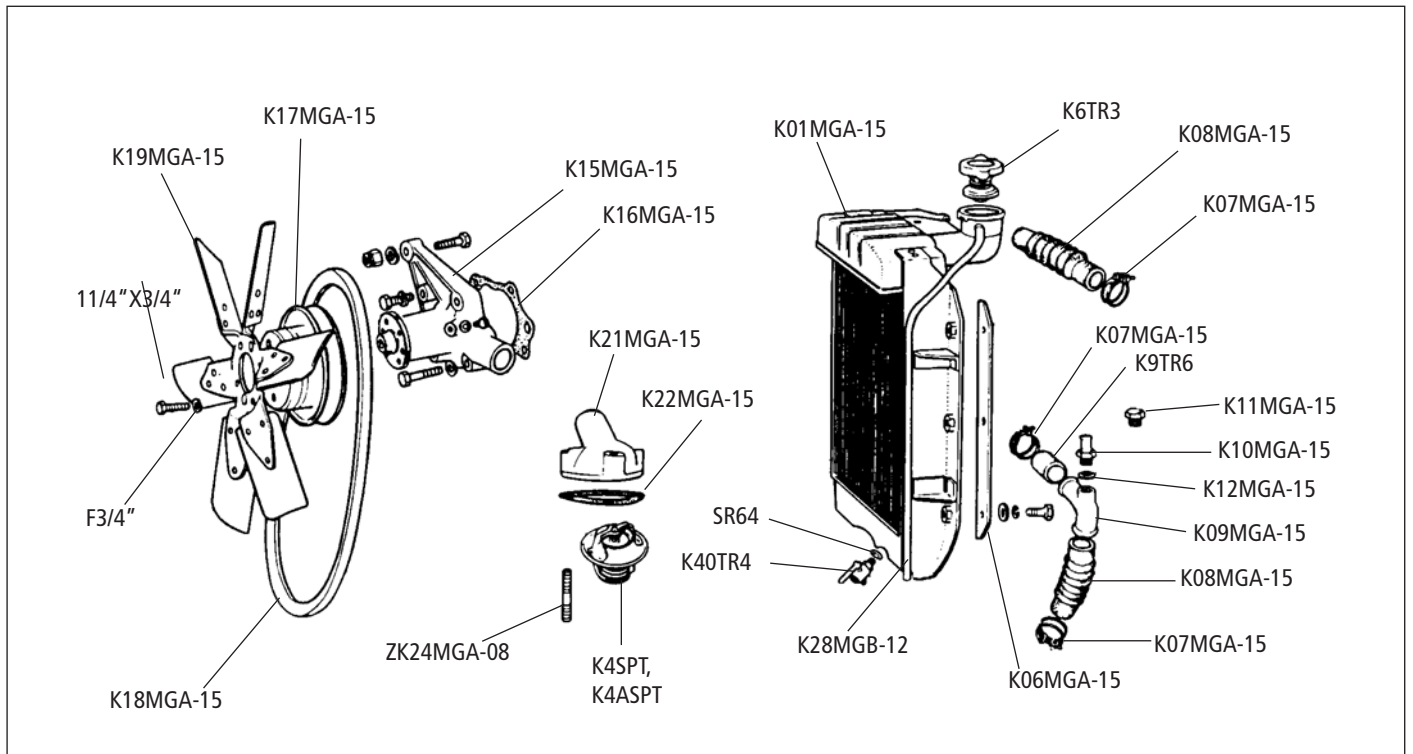

No.	Bezeichnung	Description	Anzahl/Qty.
Zusatzkühlung		Electric fan	
K20SPT	Elektrolüfter	Electric fan	1
K20ASPT	Ventilatorhalter universal (4x erforderlich)	Fan fitting kit, universal (necessary 4x)	4
K21SPT	Thermostat	Thermostat	1
K23MGA	Wasserrohr mit Anschlußgewinde	Water hose with thread	1
K200MGA	Elektrolüfter-Kit bestehend aus: K20SPT, 4x K20ASPT, K21SPT, K23MGA	Electric fan kit, contains: K20SPT, 4x K20ASPT, K21SPT, K23MGA	1
Heizung		Heater	
V01MGA-14	Defrosterschlauch „kurz“	Hose air intake „short“	2
V02MGA-14	Halteklammer	Clip retaining	3
K03MGA-32	Heizgebläse-Motor	Heater motor	1
K04MGA-32	Wärmetauscher	Heater matrix	1
K04AMGA-32	Dichtung Wärmetauscher	Heater radiator foam	1
K05MGA-32	Gummidichtring	Heater pipe seal	1
K06MGA-32	Heizungskasten	Heater box	1
K07MGA-32	Gummidichtung	Rubber seal	1
K08MGA-32	Lüfterflügel Heizungsmotor	Rotor fan heater metal	1
K09MGA-32	Lüftungsschlauch „kurz“	Hose demister „short“	1
K10MGA-32	Lüftungsschlauch „lang“	Hose demister „long“	1
K12MGA-32	Defrosterschlauch „lang“	Hose air intake „long“	1
W15TR4	Luftklappenzug	Cable fresh air control	1
K15MGA-32	Befestigung Zug Luftklappe + Heizungszug	Trunnion heater control cable	4
W16TR4	Zug Luftklappe (ohne Knopf)	Control push air distributor (without knob)	1
K16MGA-32	Umrandung Heizungsschieber	Bezel heater control	1
K17MGA-32	Knopf Luftklappe + Heizungszug	Knob air/heater cable	2
K19MGA-32	Heizungszug	Heater control cable	1
E20MGA-35	Satz Bedienungsknöpfe (5 tlg) - s. Seite 66	Knob set switches (5 pcs) - find more details on page 66	1
K20MGA-32	Zug Frischluftzufuhr (ohne Knopf)	Fresh air control cable (without knob)	1
K21MGA-32	Schieber-, Schaltereinheit Heizung/Gebläse	Heater control unit	1
K22MGA-32	Knopf Schieber-, Schaltereinheit	Knob heater control unit	1
K23MGA-32	Schlauchschele	Hose clip	4
K24MGA-32	Heizungsventil	Heater valve	1
K25MGA-32	Dichtung Heizungsventil	Heater valve gasket	1
K26MGA-32	Schlauch Heizungsrohr zum unteren Kühlerschlauch	Hose water pipe to bottom hose	1
K27MGA-32	Schlauch Heizungsrohr zur Heizung	Hose heater pipe to heater	1
K28MGA-32	Schlauch Heizungsventil zur Heizung	Hose heater valve to heater	1
K29MGA-32	Set Heizungsschläuche (einschl. Nr. K26/27/28MGA-32) (3 tlg)	Water hose set (incl. No. K26/27/28MGA-32) (3 pcs)	1
K30MGA-32	Original Drahtschelle	Wire clip	6
K43MGA-32	Klammer Kabel	Clamp cable	3
K44MGA-32	Bolzen und Buchse	Bolt and spacer	2
K45MGA-32	Klammer Gehäuse Heizung	Clip heater attachment	4
K46MGA-32	Adapterrohr Luftschlauch	Demister adapter tube	2
K47MGA-32	Adapter	Adapter	2
K48MGA-32	Wasserrücklaufleitung	Water return pipe	1

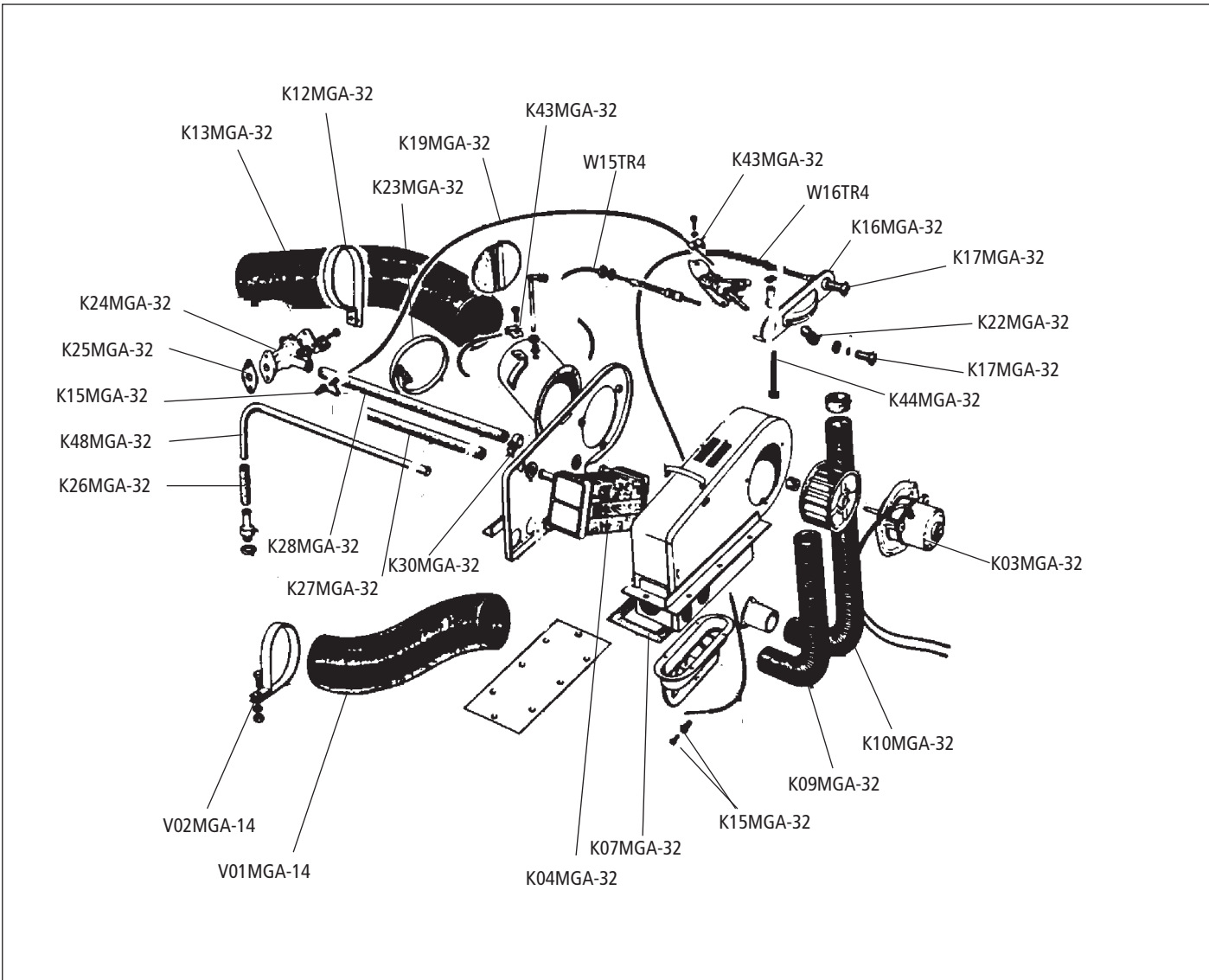
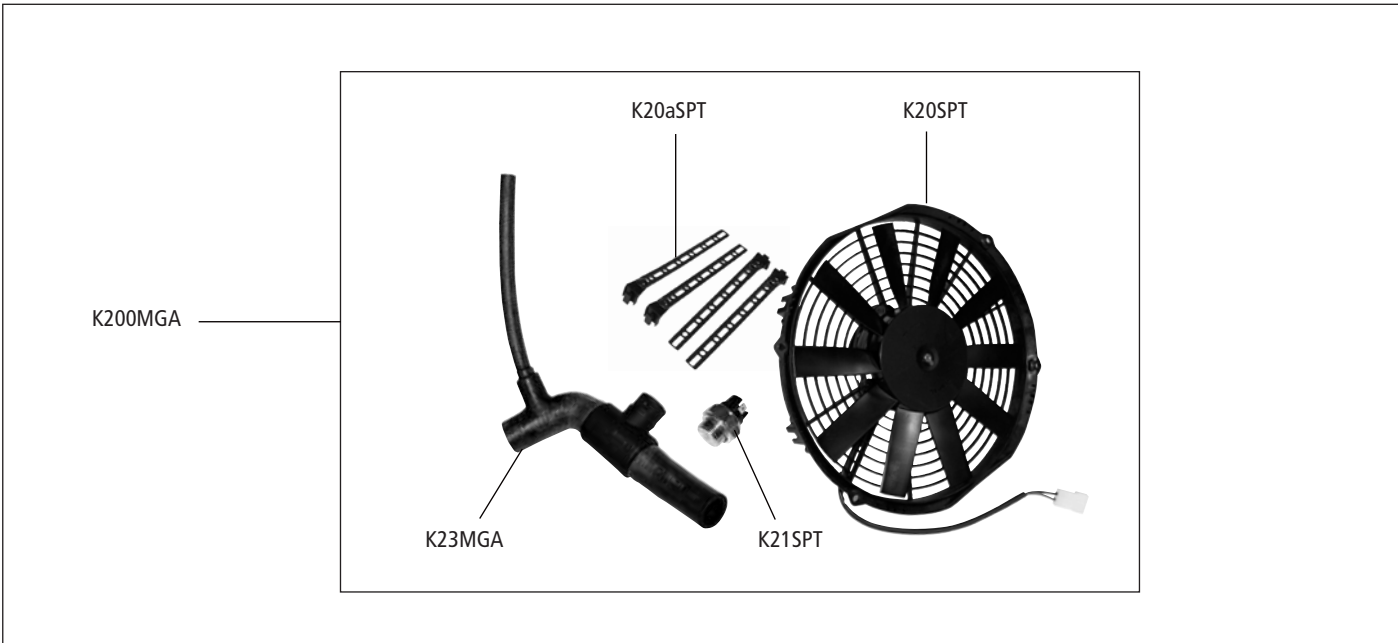

No.	Bezeichnung	Description	Anzahl/Qty.
M66MGB/F	Original-Benzinpumpe	Petrol pump positive earth	1
M66BMGB/F	Repro. –Benzinpumpe	Petrol pump positive earth (repro)	1
V03MGA-17	Kondensator Benzinpumpe	Condenser petrol pump	1
V05MGA-17	Membrane Benzinpumpe (Schaftlänge 60,30 mm)	Petrol pump diaphragm (spindle length 60,30 mm)	1
V06MGA-17	Mutter auf Ellebogenrohr	Nut on elbow pipe	1
K7	Schlauchschele für Benzinschlauch	Hose for fuel pipe	A/R
V10MGA-17	Benzintank	Petrol tank	1
V11MGA-17	Haltestreifen Benzintank	Tank strap	2
V12MGA-17	Unterlagen Haltestreifen Benzintank	Rubber packing petrol tank strap	2
V13MGA-17	Tankgeber	Tank sender unit	1
M25MGA-12	Ablaßschraube	Petrol drain plug	1
S17CSPT	Benzineinfüllschlauch	Filler hose	1
V18MGA-17	Drahtschelle	Wire clip	A/R
V19MGA-17	Benzineinfüllstutzen für Tankdeckel V50MGB	Petrol filler extension for filler cap no. V50MGB	1
V20MGA-17	Gummiring Tank/Kofferraumboden	Ferrule petrol filler extension	1
V21MGA-17	Dichtung Kofferraumboden innen	Rubber seal trunk floor	1
S22MGA-17	Benzin-Einfüllkappe	Petrol filler cap	1
V23MGA-17	Korkdichtung Benzin-Einfülldeckel	Seal petrol cap	1
V25MGA-17	Benzinleitung Tank/Pumpe	Petrol pipe tank/pump	1
V26MGA-17	Benzinleitung Pumpe/Benzinschlauch	Petrol pipe pump/petrol hose	1
V27MGA-17	Verbinder Benzinleitung/Benzinschlauch (V30MGA-17)	Union petrol pipe/main petrol feed (V30MGA-17)	1
V28MGA-17	Benzinleitung Vergaser/Vergaser	Petrol pipe carburettor/carburettor	1
V29MGA-17	Doppel-Hohlschraube	Brass double banjo	1
V30MGA-17	Benzinschlauch (Benzinleitung/Doppel-Hohlschraubenschluß)	Petroflex hose petrol pipe/banjo connection	1
V31MGA-17	Schraube Tankgeber	Screw petrol tank sender unit6	6
V32MGA-17	Winkelteil	Fuel pump elbow and washer	2
V33MGA-17	Klemmkeil Benzinleitung	Sleeve fuel pump tubing	2
V50MGB	Tankdeckel für V19MGA-17	Filler cap for no. V19MGA-17	1
V50aMGB	Tankdeckel abschließbar für V19MGA-17	Filler cap, lockable, for no. V19MGA-17	1
M63MGB	Kontaktesatz Benzinpumpe	Rocker and blade petrol pump	1
M74SPT	Dichtring Ablaßschraube	Washer petrol drain plug	1
V77SPT	Benzinschlauch Ø 6 mm, je Meter	Fuel hose Ø 6 mm, per meter	A/R
V78SPT	Benzinschlauch Ø 8 mm, je Meter	Fuel hose Ø 8 mm, per meter	A/R
V79SPT	T-Stück 8 mm	T-piece for fuel hose 8 mm	A/R
E150ATR3	Dichtscheibe Tankgeber	Gasket tank sender unit	1

No.	Bezeichnung	Description	Anzahl/Qty.
C01MGA-18	Kupplungs-Satz 1500/1600/MK2 bis 3828 (3tlg)	Clutch kit MGA1500/1600/1600 MK2 up to 3828 (3 pcs)	1
C02MGA-18	Kupplungs-Satz 1600 MK2 ab 3829 (3tlg)	Clutch kit MGA1600 MK2 from 3829 (3 pcs)	1
C03MGA-18	Kupplungsscheibe 10 Zähne (incl. Twin Cam)	Clutch plate 10 teeth (incl. Twin Cam)	1
C04MGA-18	Kupplungsscheibe 23 Zähne	Clutch plate 23 teeth	1
B04MGA-20	Hohlschraube 1500 bis 11767	Banjo bolt 1500 up to 11767	1
B05MGA-20	Banjo-Verbindung 1500 bis 1176725	Banjo union 1500 up to 11767	1
C05MGA-18	Kupplungsautomat	Clutch cover	1
C5MGA/TC	Kupplungsgeberzylinder Twin Cam + Deluxe	Clutch master cylinder Twin Cam + De Luxe	1
C06MGA-18	Kupplungsaustrücklager	Clutch release bearing	1
C6SPT	Rep-Satz Kupplungs-Geberzylinder Twin Cam + Deluxe	Repair kit clutch master cylinder Twin Cam + De Luxe	1
S5/16"x7/8"	Befestigungsschraube Kupplungsautomat S5/16"x7/8"	Setscrew clutch cover S5/16"x7/8"	6
C08MGA-18	Klammer Kupplungsaustrücklager	Clutch bearing clip side	2
C09MGA-18	Feder Anlaufplatte Kupplungsautomat	Clip clutch cover thrust plate	3
C10MGA-18	Lagerbuchse Kupplungshebel 1500 bis 4524	Bush clutch release lever 1500 up to 4524	1
C11MGA-18	Lagerbuchse Kupplungshebel 1500 ab 4525/1600 MK2	Bush clutch release lever 1500 from 4525/1600 MK2	1
C12MGA-18	Bolzen Kupplungshebel 1500 bis 4524	Bolt clutch release lever 1500 up to 4524	1
C13MGA-18	Bolzen Kupplungshebel 1500 ab 4525 /1600 MK2	Bolt clutch release lever 1500 from 4525/1600 MK2	1
B14MGA-20	Rückholfeder	Pull-off-spring pedal	1
M3/8"	Mutter für Bolzen C12MGA-18	Nut on bolt no. C12MGA-18	1
C15MGA-18	Mutter für Bolzen C13MGA-18	Nut on bolt no. C13MGA-18	1
B15MGA-20	Lagerbuchse	Bearing bush	1
C16MGA-18	Kupplungs-Nehmerzylinder	Clutch slave cylinder	1
C17MGA-18	Überholersatz Kupplungs-Nehmerzylinder (für C16MGA-18)	Repair kit clutch slave cylinder (to use with C16MGA-18)	1
C18MGA-18	Druckstange Kupplungs-Nehmerzylinder	Push rod clutch slave cylinder	1
C19MGA-18	Verbindungsstift	Clevis pin	1
B19MGA-20	Pedalgummi	Pedal rubber	2
C20MGA-18	Befestigungsbolzen Nehmerzylinder/Getriebe	Bolt clutch slave cylinder/gearbox	2
C21MGA-18	Entlüftungsrippel	Bleed nipple	1
B21MGA-22	Kupferscheibe	Copper washer	1
C22AMGA-18	Kupferscheibe 1500 bis 11767	Washer copper 1500 up to 11767	1
C27MGA/TC	Kupplungsleitung Twin Cam + Deluxe LHD	Pipe clutch master cylinder/clutch hose lhd Twin Cam + De Luxe	1
C27MGA/TC-RHD	Kupplungsleitung Twin Cam + Deluxe RHD	Pipe clutch master cylinder/clutch hose rhd Twin Cam + De Luxe	1
C27MGA-18	Leitung Kupplungs-Geberzylinder/Kupplungsschlauch Lhd	Pipe clutch master cylinder/clutch hose lhd	1
C28MGA-18	Leitung Kupplungs-Geberzylinder/Kupplungsschlauch Rhd	Pipe clutch master cylinder/clutch hose rhd	1
C31AH	Kupplungs-Nehmerzylinder Twin Cam + Deluxe	Push rod clutch slave cylinder Twin Cam + De Luxe	1
C32AH	Reparatursatz Kupplungs-Nehmerzylinder	Clutch slave repair kit	1
C34MGA-18	Zentrierwerkzeug Kupplung (10 Zähne)	Clutch tool (10 teeth)	1
C35MGA-18	Zentrierwerkzeug Kupplung (23 Zähne)	Clutch tool (23 teeth)	1
C36MGA-18	Manschette Kupplungshebel	Gaiter clutch fork	1
SR50	Splint	Split pin	A/R
B56MG	Gummi-Kupplungsschlauch	Clutch slave hose rubber	1
B56MGAQ	Aeroquip-Kupplungsschlauch stahlummantelt, für Sportzwecke	Clutch slave hose aeroquip armoured stainless steel for competition use	1
B58ATR	Kupplungsschlauch Twin Cam + Deluxe	Clutch slave hose steel reinforced Twin Cam + De Luxe	1
B58b	Kontermutter Bremsschlauch/Kupplungsschlauch	Lock nut brake hose/clutch slave hose rubber	1
B58c	Kupferdichtung für Bremsschlauch	Copper washer for brake hose	1
B58d	Zahnscheibe für Bremsschlauch	Star-washer for brake hose	1
B69SPT	Bolzen 5/16"	Clevis pin 5/16"	1
BR05	Kupplungsflüssigkeit 1/2 l	Clutch fluid 1/2 l	A/R
BR-Si05	Silikon Brems/Kupplungsflüssigkeit 1/2 l *	Silicone brake/clutch fluid 1/2 l *	A/R
BR-Si1	Silikon Brems/Kupplungsflüssigkeit 1 l *	Silicone brake/clutch fluid 1 l *	A/R

*** Anmerkungen zu BR-Si05, BR-Si1:**

Silikon Brems/Kupplungsflüssigkeit zieht keine Feuchtigkeit an, wodurch Rostansatz in den Leitungen vermieden und die Flüssigkeit auch nicht mehr jährlich gewechselt werden muß.

Sie weist zudem einen höheren Siedepunkt auf, verträgt sich mit allen Gummimanschetten und greift Lacke/Farben nicht an.



ACHTUNG! Silikon Brems- und Kupplungsflüssigkeit darf nicht mit einer anderen Brems/Kupplungsflüssigkeit vermischt werden!

*** Note to BR-Si05, BR-Si1:**

Silicone brake/clutch fluid does not absorb moisture from air like ordinary brake fluid. As a result, the brake/clutch pipes, the cylinders and hoses will last much longer and you do not have to change the fluid at least once a year. Also silicone brake/clutch fluid has a slightly higher boiling point.



WARNING! It is not possible to mix with other brake/clutch fluid!

Doppelzylinder
s. Seite 63 /
Twin clutch cylinder
on page 63

C5MGA/TC



C6SPT



C32AH

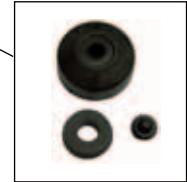

SR50

B69SPT

B15MGA-20

B14MGA-20

B19MGA-20

C27+28MGA-18

B58d

B58b

C16MGA-18
C31AH

B58c

B56MG, B56MGAQ
B58ATR

C22AMGA-18

C18MGA-18

C17MGA-18

B04MGA-20

C19MGA-18

B05MGA-20

C09MGA-18

C07MGA-18

B21MGA-22

C08MGA-18

C21MGA-18

M3/8"

C15MGA-18

C20MGA-18

C10+11MGA-18

C03+04MGA-18

C12+13MGA-18

C06MGA-18

C36MGA-18

C05MGA-18

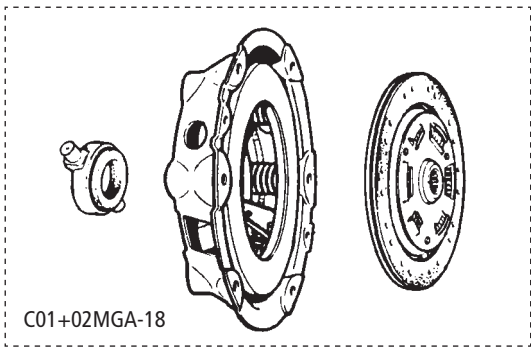

C01+02MGA-18



C34MGA-18,
C35MGA-18



BR05 **

No.	Bezeichnung	Description	Anzahl/Qty.
G1MGA/..	AT-Getriebe - in verschiedenen Ausführungen	Exchange gear boxes - different specifications	1
G01MGA-19	Getriebe-Dichtsatz (ohne Simmerringe)	Gasket set gearbox (without oil seals)	1
G02MGA-19	Simmerring Getriebe vorne	Oil seal gearbox front	1
G04MGA-19	Einfüll-/Ablab-Stopfen	Oil drain/filler plug	1
G05MGA-19	1.-Gangrad	1st gear	1
G05MGA-19/a	1.-Gangrad Außenteil	1st gear (outer part)	1
G06MGA-19	Synchronring 2.-Gang „Messing“	Baulk ring 2nd gear „brass“	1
G07MGA-19	Synchronring 2.-Gang „Stahl“ (nur mit neuem Gangrad Nr. G13MGA-19)	Baulk ring 2nd gear „steel“ (use with new gear no. G13MGA-19)	1
G08MGA-19	Synchronring 3. + 4.Gang „Messing“	Baulk ring 3rd + 4th „brass“	2
G09MGA-19	Buchse 3.-Gang	3rd gear bush	1
G10MGA-19	3.-Gang-Rad	3rd speed gear	1
G11MGA-19	Synchronkörper 3 + 4 Gang	Synchroniser 3rd + 4th gear	1
G12MGA-19	Buchse 2.-Gang	2nd gear bush	1
G13MGA-19	2.-Gang-Rad	2nd speed gear	1
G13SPT	Lager Getriebehals ab 15Gd	Rear extension bearing from 15Gd	1
G14MGA-19	Nadel Nadellager Getriebeeingangswelle	Needle roller	18
G15MGA-19	Lager Getriebeeingangswelle	Bearing gearbox input shaft	1
G16MGA-19	Sicherungsring Lager Eingangswelle	Spring ring input shaft bearing	1
G17MGA-19	Sicherungsscheibe	Lock washer	1
G18MGA-19	Kontermutter Eingangswelle	Nut 1st motion shaft	1
G19MGA-19	Vorgelegewelle	Layshaft	1
G20MGA-19	Vorgelegezahnkranz	Laygear	1
G21MGA-19	Nadellager Vorgelegewelle	Countershaft bearing	3
G22MGA-19	Sprengring Vorgelegewelle	Circlip countershaft	3
G23MGA-19	Anlaufscheibe Vorgelege vorne	Thrust washer countershaft front	1
G24MGA-19	Anlaufscheibe Vorgelege hinten „0.155“	Thrust washer countershaft rear „0.155“	A/R
G24AMGA-19	Anlaufscheibe Vorgelege hinten „0.157“	Thrust washer countershaft rear „0.157“	A/R
G25MGA-19	Anlaufscheibe Vorgelege hinten „0.160“	Thrust washer countershaft rear „0.160“	A/R
G25AMGA-19	Anlaufscheibe Vorgelege hinten „0.163“	Thrust washer countershaft rear „0.163“	A/R
G26MGA-19	Ölmeßstab	Dipstick gearbox	1
G29MGA-19	Simmerring Getriebe hinten ab 15Gd	Rear oil seal gearbox from 15Gd	1
D30MGA-26	Kontermutter	Nut	1
G30MGA-19	Schalthebelmanschette	Gearbox gaiter	1
G31MGA-19	Sicherungsclip Schalthebel	Gear lever circlip	1
G32MGA-19	Federdeckel Schalthebel	Gear lever spring cover	1
G33MGA-19	Feder Schaltknüppel	Change speed lever spring	1
S34MGA-19	Original-Schaltknopf	Original gear lever knob	1
S35MGA-19	Holz- Schaltknopf mit -MG-Emblem (Vollgummi-Einsatz)	Wooden gear knob with -MG- logo (nylon thread insert)	1
S36MGA-19	Leder-Schaltknopf mit -MG-Emblem (Vollgummi-Einsatz)	Leather gear knob with -MG- logo (nylon thread insert)	1
S24MGA-50	Holz-Schaltknopf mit -MG-Emblem (Metall-Innengewinde)	Wooden gear knob with -MG- logo (metal thread insert)	1
G41MGA-19	Rückwärtsgangrad	Reverse gear	1
G42MGA-19	Simmerring (Blechgehäuse mit Filz) (Kardanwelle mit Schiebestück)	Rear oil seal gearbox (metal housing with felt) (Propeller shaft with sliding centre piece)	1
G43MGA-19	Simmerring 1500 bis 15Gb (Kardanwelle mit Schiebestück)	Seal gearbox early 1500 up to 15Gd (Propeller shaft with sliding centre piece)	1
G44MGA-19	Feder Kolben	Spring plunger	1
G45MGA-19	Buchse	Bush	1
G46MGA-19	Stift	Pin	2
G47MGA-19	Schaltknüppel	Gear lever	1
G48MGA-19	Kupferscheibe	Copper washer	1
G49MGA-19	Feder	Spring	2
G50MGA-19	Kolben	Plunger	1
G51MGA-19	Welle Rückwärtsgang	Reverse shaft	1
G53MGA-19	Anlaufscheibe „3.962-3.988“	Thrust washer „3.962-3.988“	A/R
G53AMGA-19	Anlaufscheibe „4.013-4.039“	Thrust washer „4.013-4.039“	A/R
G53BMGA-19	Anlaufscheibe „4.060-4.085“	Thrust washer „4.060-4.085“	A/R
G37MGA-19	Tachowelle (62")(158 cm) Rechtslenker	Speedo cable (62")(158 cm)	1
G39MGA-19	Tachowelle (66")(168 cm) Rechtslenker	Speedo cable (66")(168 cm)	1
W1SPTMK3	Tachowelle (69")(176 cm) Linkslenker	Speedo cable (69")(176 cm)	1

* Fortsetzung nächste Seite

* to be continued on next page

No.	Bezeichnung	Description	Anzahl/Qty.
G54MGA-19	Sicherungsring	Interlocking ring	1
G55MGA-19	Anlaufscheibe hinten	Thrust washer rear	1
G57MGA-19	Lager Hauptwelle	Bearing roller mainshaft	1
G58MGA-19	Feder	Spring	6
G20SPT	Kugel	Ball	A/R
G60MGA-19	Kugel	Ball	6
G61MGA-19	Kugel	Ball	3
G63MGA-19	Getriebeaufhängung hinten	Rear gearbox mounting	1
G70MGA-19	Senkkopfschraube 5/16" UNF bis (g)A8010	Countersunk screw 5/16" UNF bis (g)A8010	3
G70AMGA-19	Senkkopfschraube 5/16" UNC ab (g)A8011	Countersunk screw 5/16" UNC from (g)A8011	3
G71MGA-19	Scheibe	Washer	3
G101VO	Dichtring Antriebsritzel Tacho	Oil seal speedo pinion drive	1
G102MGA	Dichtung Tachoantriebsgehäuse	Oil seal speedo pinion drive housing	1
GE	Hypoid Getriebe/Differentialöl SAE80W90, pro Liter	Hypoid Gearbox/Differential oil SAE80W90, per liter	A/R

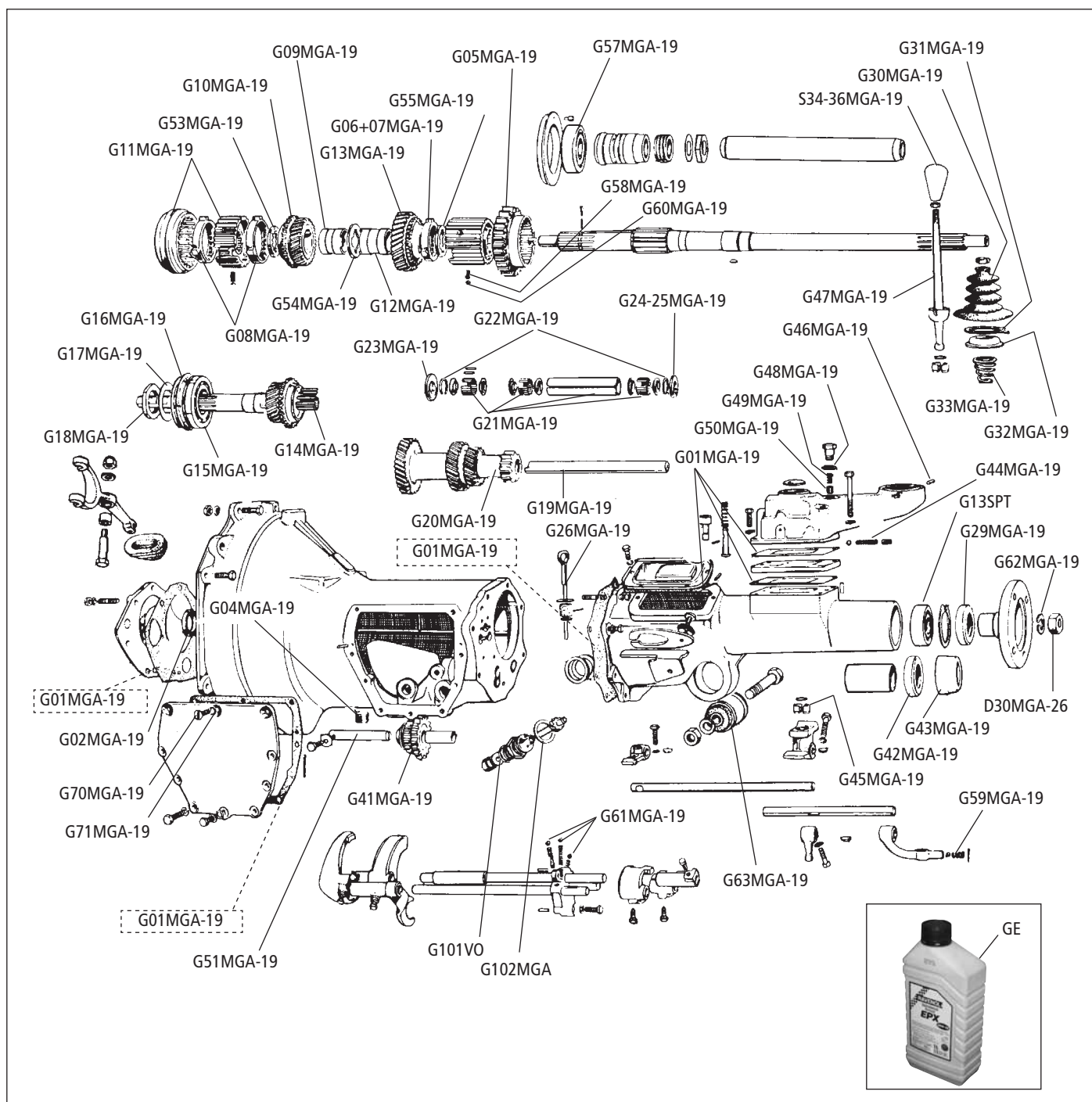

**Hinweis
Note:**zu Motorteile
ab Seite 4.. engine parts
page 4 ff.

Bitte beachten Sie:

Das Altteil 'Motor' ist uns **ohne** folgende Teile anzuliefern:

- Vergaser und Ansaugstutzen
- Einlaß/Auslaßstehbolzen
- Auspuffkrümmer
- Ventildeckel
- Verteilerantrieb
- Wasserpumpe und Wasserpumpengehäuse
- Thermostatgehäuse
- Lichtmaschine mit Halter
- Keilriemenscheibe
- Stehbolzen Verteiler
- Benzinpumpe
- Stehbolzen Benzinpumpe
- Ölfiltergehäuse

Bitte nicht vergessen:

Öl ablassen und Motor vor Anlieferung außen reinigen!

Please obey: The old engines should be sent to us without the following components: :

- carburetter and intake manifold,
- all manifold studs,
- exhaust manifold,
- valve cover,
- distributor and - drive,
- water pump and -housing,
- thermostat housing,
- alternator,
- v-belt disk,
- fuel pump,
- distributor and fuel pump studs

Don't forget:

Remove the oil and to clean the housing before delivery.

**Hinweis
Note:**zu Getriebe
ab Seite 38.. gear box
page 38 ff.Altteile für AT-Getriebe bitte ohne Schalthebel, ohne Ausrückgabel u. -welle, ohne elektr. Schalter und **ohne** Tachoantrieb und in außen gut gereinigtem Zustand anliefern!**Bitte nicht vergessen:** Öl ablassen!Please supply us your gear box exchange parts without shifting lever, shifting fork and -shaft, **w/o** electrical switches and w/o tacho drive**Don't forget:**

Please remove oil and supply exchange parts mounted, complete and cleaned.

**Hinweis
Note:**Differential
ab Seite 44.. differential
page 44 ff.

Altteile für AT-Differential bitte wie rechts abgebildet in komplettem und gut gereinigtem Zustand anliefern!

Bitte nicht vergessen: Öl ablassen!

Please supply us your differential exchange as shown in figure on the right, complete and cleaned.

Don't forget:

Please remove oil and supply exchange parts mounted, complete and cleaned.

Abb.: AT-Motor / Fig. Engine, exchange

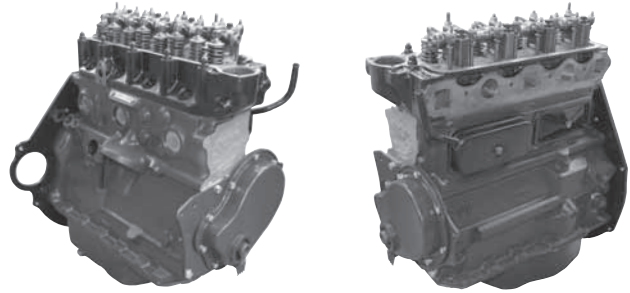

(Abb./Fig. MGB)

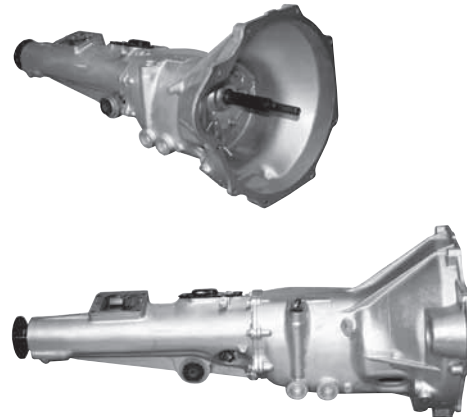
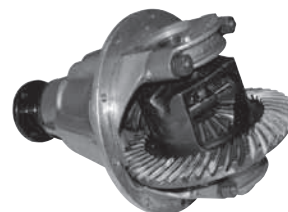
Abb.: AT-Getriebe /
Fig.: Gear box, exchangeAbb.: AT-Differential /
Fig.: Differential, exchange

No.	Bezeichnung	Description	Anzahl/Qty.
HA01MGA-25	Stoßdämpfer rechts	Rear shock absorber right hand	1
HA02MGA-25	Stoßdämpfer links	Rear shock absorber left hand	1
S7/16"X31/2"	Befestigungsschrauben Stoßdämpfer	Bolt rear shock absorber	4
HA06MGB-19	Stoßdämpfer-Verbindungsarm	Shocker link	2
HA08MGA-25	Blattfeder (einschl. HA09MGA-25)	Rear spring (incl. Bush no HA09MGA-25)	2
HA09MGA-25	Lagerbuchse	Bush	2
S7/16"X3"	Bolzen Blattfeder vorne	Bolt rear spring front	2
M7/16"	Mutter	Nut	2
HA12MGA-25	Herz-Bolzen	Bolt spring centre	2
HA13MGA-25	Gummiauflage	Spring pad	4
HA14MGA-25	Federplatte	Spring plate	4
HA15MGA-25R	Halteblech Stoßdämpferarm rechts	Shocker bracket right hand	1
HA15MGA-25L	Halteblech Stoßdämpferarm links	Shocker bracket left hand	1
HA17MGA-25	U-Bolzen Blattfeder	U-bolt rear spring	4
M3/8"	Mutter	Nut	8
HA19MGA-25	Achsfangband	Rebound strap	2
HA20MGA-25	Anschlaggummi	Bump stop	2
HA21MGA-25	Anschlagplatte U-Bolzen	U-bolt top plate	2
HA23MGA-25	Blattfedergehänge mit Bolzen	Shackle plate with pins	2
HA41TR	Gegenplatte Blattfedergehänge	Shackle plate	2
M3/8"	Mutter	Nut	4
HA29MGB	Umrüstsatz auf Teleskop-Stoßdämpfer, hinten - mit TÜV-Gutachten - einfachste Montage, da keinerlei Schweißarbeiten erforderlich; merkliche Verbesserung der Straßenlage durch deutliche Erhöhung der Stoßdämpferwirkung!	Telescopic shock absorber conversion kit, rear - with TÜV approval - easy to fit! No welding needed. Improves the rate of damping!	1
			
HA30MGA-25	Kardanwelle (2 Flansch)	Propshaft (2x flange)	1
HA30aMGA-25	Kardanwelle (Flansch nur auf einer Seite) 1500 früh	Propshaft (only 1 x flange) early 1500	1
HA32MGA-25	Kardanwellenschraube (4/8)	Bolt, prop shaft (4/8)	4/8
HA33MGA-25	Mutter Kardanwellenschraube (4/8)	All metal nut (4/8)	4/8
HA35TR	Lagerbuchse Blattfedergelenk	Shackle plate bush	8
HA35aTR	Nylonbuchse Blattfeder (als Ersatz für HA35TR)	Nylon bush shackle plate (replacing no. HA35TR)	8
HA36MGA-25	Schmiernippel (1600 + MK2)	Grease nipple (1600 + MK2)	1
HA37MGA-25	Schiebehülse (1600 + MK2)	Sleeve (1600 + MK2)	1
HA40MGA-25	Schmiernippel „lang“ Kreuzgelenk	Grease nipple long	1
D54aSPTMK3	Kardanwellen-Flansch (1500 =1x) (1600 =2x)	Flange (1500 =1x) (1600 =2x)	1
D55aSPT	Kreuzgelenk mit Schmiernippel	Universal joint with grease nipple	2
D55SPT	Kreuzgelenk	Universal joint	2
VA80aMGB	Stoßdämpfer Koni für HA29MGB	Koni shock absorber (to use with conversion kit HA80AMGB)	2
HSD	Stoßdämpferöl, pro Liter	Shock absorber oil, per liter	A/R

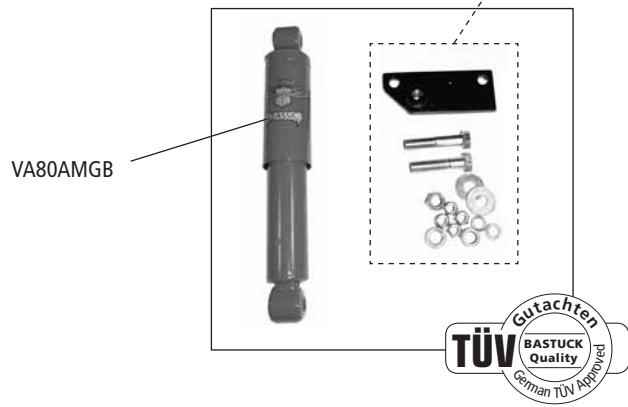
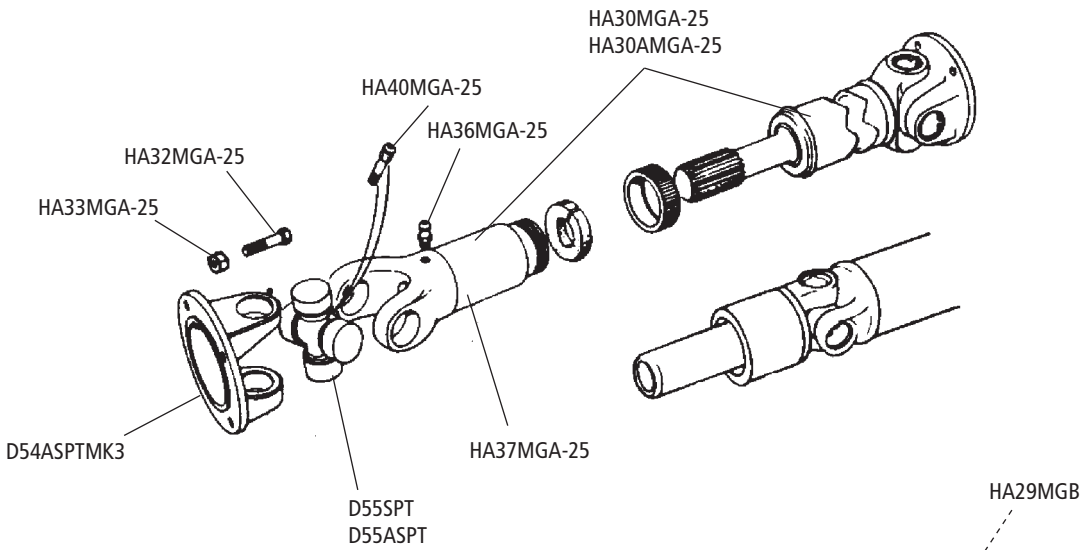
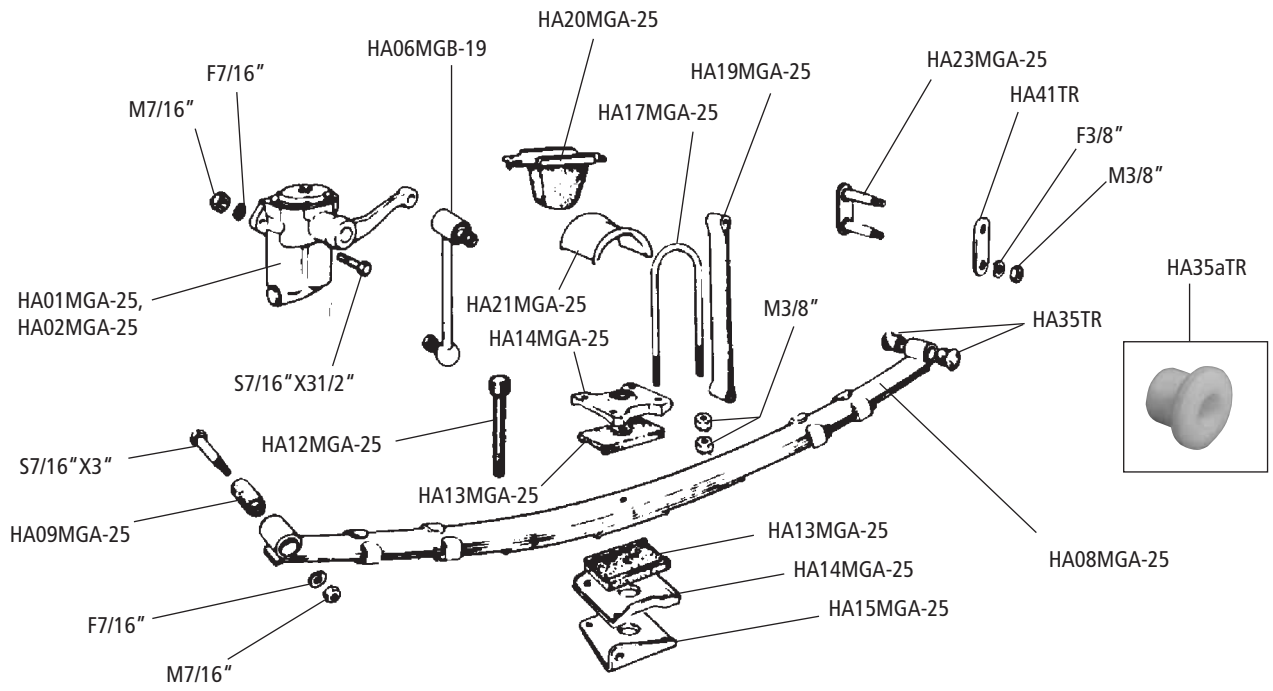

No.	Bezeichnung	Description	Anzahl/Qty.
D01MGA/..	AT-Differential mögliche Übersetzungen: 3.7,3.9,4.1,4.3,4.55	Exchange differential please refer transmission: 3.7,3.9,4.1,4.3,4.55	1
D01MGA-26	Mutter links (Rechtsgewinde)	Nut right hand (right hand thread)	1
D02MGA-26	Mutter rechts (Linksgewinde)	Nut left hand (left hand thread)	1
G04MGA-19	Einfüll-/Ablaß-Stopfen Hinterachse	Oil drain / filler plug differential	2
D04MGA-26	Entlüftungsventil	Breather differential cover	1
D05MGA-26	Differentialdichtung	Gasket differential cover	1
D06MGA-26	Differentialkäfig	Cage differential	
D07MGA-26	Sicherungsring	Lock washer	2
D08MGA-26	Lager Abtriebsseite	Bearing differential side	2
D09MGA-26	Ausgleichsscheibe 0.002"	Shim 0.002"	A/R
D10MGA-26	Ausgleichsscheibe 0.003"	Shim 0.003"	A/R
D11MGA-26	Ausgleichsscheibe 0.006"	Shim 0.006"	A/R
D11MGB-16	Flansch Kegelrad	Flange (pinion)	1
D12MGA-26	Anlaufscheibe Ausgleichsrad Abtriebsseite	Thrust washer differential side	2
D13MGA-26	Anlaufscheibe Ausgleichsrad	Thrust washer differential	2
D14MGA-26	Welle Ausgleichsräder	Pin pinion	1
D15MGA / ...	Teller- und Kegelrad - bitte Übersetzung angeben: 3.7, 3.9, 4.1, 4.3, 4.55	Bevel wheel and ring gear - please refer transmission 3.7, 3.9, 4.1, 4.3, 4.55	1
D15MGA-26	Sicherungsstift	Plug	1
D16MGA-26	Bolzen Tellerrad/Differentialkäfig	Bolt crown wheel/ cage differential	8
D17MGA-26	Sicherungsscheibe Bolzen Tellerrad	Lock washer crown wheel	4
D18MGA/..	Anlaufscheibe Kegelrad - bitte Größe angeben: 0.118",0.120",0.122",0.124",0.126"	Pinion thrust washer - please refer dimension: 004",006",008",010",012",020",030"	A/R
D29TR	Lager Kegelrad innen	Bearing taper roller pinion inner	1
D21MGA-26	Distanzstück	Spacer bearing	1
D22MGA-26	Lager Kegelrad außen	Bearing taper roller pinion outer	1
D23MGA/..	Anlaufscheibe bitte Größe angeben: 004",006",008",010",012",020",030"	Thrust washer - please refer dimension: 004",006",008",010",012",020",030"	A/R
D26MGA-26	Simmerring Hinterachseingang	Oil seal differential pinion	1
D27MGA-26	Staubkappe	Cap differential pinion	1
D29MGA-26	Federring	Spring washer	1
D30MGA-26	Mutter	Nut	1
D31MGA-26	Antriebswelle (Speichenräder) 1500 (10 Zähne)	Halfshaft (wire wheels) 1500 10 splines	2
D32MGA-26	Antriebswelle (Speichenräder) 1600 bis 82748 (26 Zähne)	Halfshaft (wire wheels) 1600 up to 82748 26 splines	2
D33MGA-26	Antriebswelle (Speichenräder) 1600 ab 82749 (25 Zähne)	Halfshaft (wire wheels) 1600 from 82749 25 splines	2
D34MGA-26	Verschlußstopfen (Speichenräder)	Core plug wire wheel hub	2
D35MGA-26	Speichenradnabe rechts	Rear wire wheel hub right hand	1
D36MGA-26	Speichenradnabe links	Rear wire wheel hub left hand	1
D37MGA-26	Antriebswelle (Stahlfelgen) 1500 10 Zähne	Halfshaft (steel wheels) 1500 10 splines	2
D38MGA-26	Antriebswelle (Stahlfelgen) 1600 bis 82692 (26 Zähne)	Halfshaft (steel wheels) 1600 up to 82692 (26 splines)	2
D39MGA-26	Antriebswelle (Stahlfelgen) 1600 ab 82693 (25 Zähne)	Halfshaft (steel wheels) 1600 from 82692 (25 splines)	2
D40MGA-26	Dichtung Radflansch	Hub gasket	2
D40MGA/TC	Dichtung Radflansch (Twin Cam)	Hub gasket (Twin Cam)	2
D41MGA-26	Radbolzen Stahlfelge	Wheel stud steel wheels	8
D42MGA-26	Radbolzen Speichenfelge	Wheel stud wire wheels	8
D43MGA-26	O-Ring	O-ring	2
D44MGA-26	Simmerring	Axle hub oil seal	2
D45MGA-26	Radlager	Rear hub bearing	2
D46MGA-26	Distanzring Stahlfelge	Bearing spacer steel wheels	2
D47MGA-26	Radlagersatz hinten (enthält: je 1 x Nr. D40/43/44/45)	Rear axle hub bearing kit (contents: 1x no. D40/43/44/45)	2
D53MGA-26	Ritzel Planetenrad	Pinion differential	2
F13TR	Radmutter Stahlfelge	Wheel nut steel wheels	8
M7/16"	Mutter Speichenfelge	Nut	8
D300MGA	Schlüssel für Radflanschnutter	Rear hub nut socket	A/R
GE	HYPOID Getriebe/Differentialöl SAE 80W90, pro Liter	Hypoid gearbox/differential oil SAE 80W90, per liter	A/R

Hinweis 
Note:

* Differentialsperre D90MGA auf Anfrage!

Anmerkung: Umrüstung auf Speichenräder, hinten wie vorne, ohne Änderung der Antriebswelle - siehe Seite 55!

* Limited slip differential No. D90MGA - on request!

Note: easy conversion from steel to wire wheel, without changing halfshafts - see page 55!

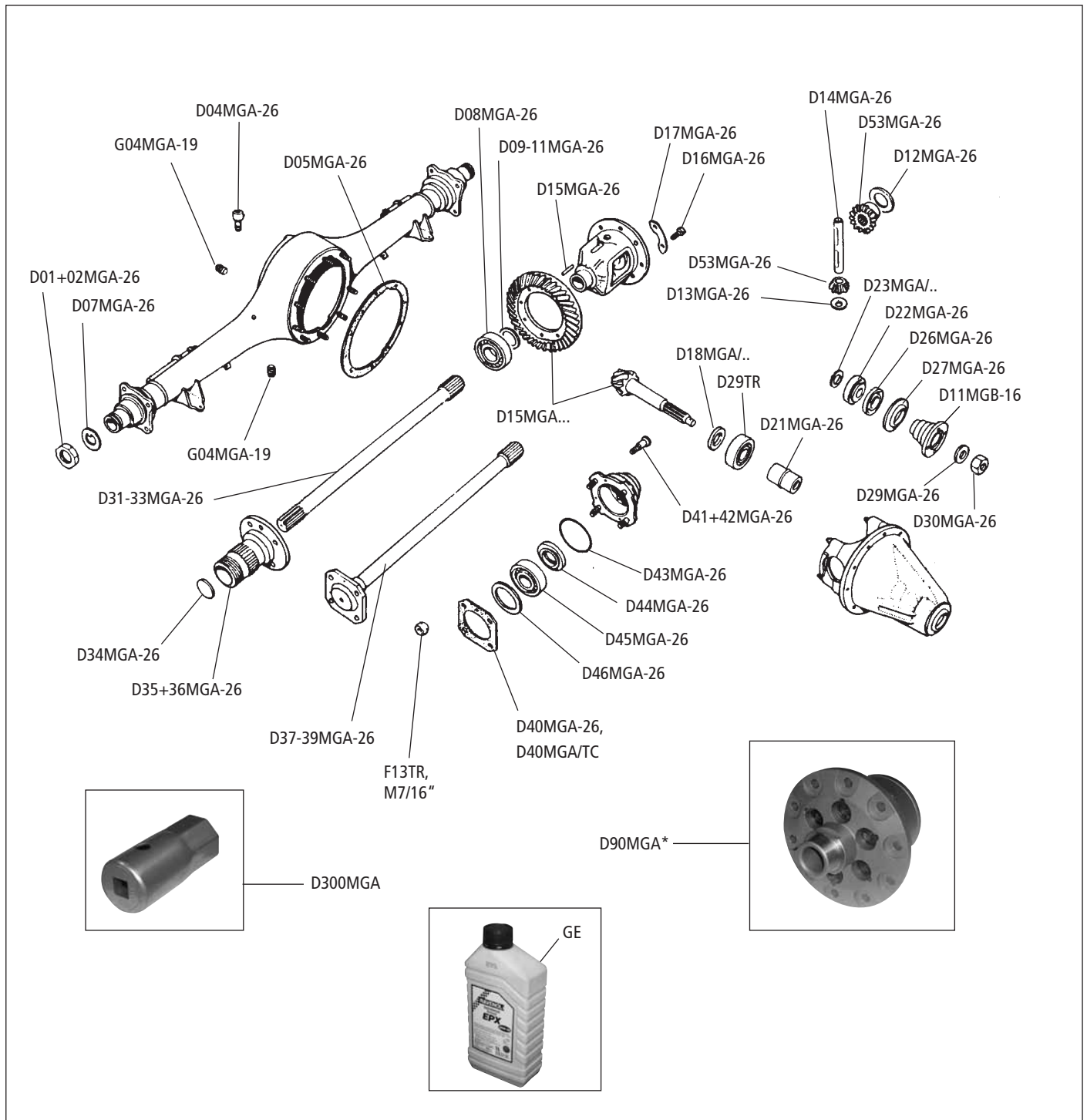

Hinweis 
Note:

Austausch-Differential Banjo-Achse: **3 Jahre Garantie** auf mechanische Teile. Überholung in unserer eigenen Werkstatt ! - Beachten Sie auch unsere Hinweise auf Seite 41!

Exchange differential Banjo-type: **3 years guarantee** on mechanical parts. The differential will be refurbished and remounted in our own workshop ! - Please refer to our notes on page 41 !



No.	Bezeichnung	Description	Anzahl/Qty.
VA01MGA-23	Überholsatz Vorderachse (beidseitig) (enthält: Nr. VA05/06/07/08/09/10/11/12MGA-23)	Major suspension kit (both sides) (Contents: no. VA05/06/07/08/10/11/12MGA-23)	1
VA02MGA-23	Überholsatz Vorderachse (beidseitig) (enthält: siehe Nr. 1, die Querlenkerbuchsen unten jedoch in verstärkter Ausführung (siehe VA13MGA-23))	Major suspension kit uprated (both sides) (Contents: the same as no.1 but item VA13MGA-23 in uprated version)	1
VA03MGA-23	Gummibuchsensatz Vorderachse (enthält: Nr. VA06+12MGA-23) (beidseitig)	Lower suspension rubber kit (Contents: no. VA06+12MGA-23)(both sides)	1
VA05MGA-24	Simmerring Radlager (außer MK2 De Luxe/Twin Cam)	Oil seal front hub outer (except MK2 de Luxe/Twin Cam)	2
VA05MGA-23	Buchse Achsschenkel oben (Bronze)	Bronze bush	4
VA06MGA-23	Dichtung Achsschenkelbolzen	King pin seal	4
VA08MGA-23	Distanzbuchse	Tube distance link	4
VA09MGA-23	Druckscheibe	Thrust washer king pin	8
VA10MGA-23	Trägerscheibe Staubdichtring	Seal support	8
VA11MGA-23	Staubdichtring	King pin dust seal	8
VA12MGA-23	Gummibuchse Querlenker „Standard“	Wishbone arm bush „standard“	8
VA13MGA-23	Gummi/Stahlbuchse Querlenker „verstärkt“ zur „Straffung“ der Vorderachse; Erhöhung der Langlebigkeit	Lower wishbone arm bush „uprated“ heavy duty rubber/steel Highly recommended for improved control and less suspension deviation during braking and cornering	4
F1/2"	Federring	Spring washer	4
VA24SPT	Kronenmutter	Crown nut	2
SR52	Splint	Split pin	8
VA16MGA	Keil	Key	2
VA17MGA-23	Unterlegscheibe	Retaining washer	4
VA18MGA-23	Drehzapfen Querlenker unten	Bottom wishbone pivot	2
VA19MGA-23	Querlenker-Arm (Wagen ohne Stabi)	Wishbone arm (cars without front anti-roll bar)	4
S5/16" X7/8"	Schraube	Setscrew	4
S5/16" X1"	Schraube	Setscrew	4
M5/16"	Mutter	Nut	8
VA23MGA-23	Federteller	Front spring pan	2
VA24MGA-23	Drehgelenk unten rechts	Swivel link right hand	1
VA25MGA-23	Drehgelenk unten links	Swivel link left hand	1
VA26MGA-23	Bolzen Drehgelenk unten	Bolt wishbone to link	2
VA26MGA-24	Schraube	Bolt	8
VA27MGA-24	Stehbolzen	Stud	8
VA27MGA-23	Achsträgerbolzen rechts	King pin right hand	1
VA28MGA-23	Achsträgerbolzen links	King pin left hand	1
VA29MGA-23	Drehgelenk oben rechts	Top swivel link right hand	1
VA30MGA-23	Drehgelenk oben links	Top swivel link left hand	1
VA31MGA-23	Schmiernippel	Grease nipple idler bracket	4
VA32MGA-23	Bolzen Drehgelenk oben	Bolt shock absorber to link	2
VA33MGA-23	Stoßdämpfer	Front shock absorber	2
VA35MGA-23	Anschlaggummi Stoßdämpfer	Rebound rubber	2
VA36MGA-23	Distanzstück Anschlaggummi	Distance piece rebound buffer	2
VA37MGA-23	Spiralfeder 1500 bis 15151	Front spring 1500 up to 15151	2
VA37AMGA-23	Spiralfeder verstärkt + verkürzt, mit TÜV-Gutachten (33,5 cm lang)	Front spring reinforced + short - with TÜV approval (33.5cm length)	2
VA38MGA-23	Spiralfeder 1500 bis 15152 + 1600 + MK2	Front spring 1500 from 15152 + 1600 + MK2	2
VA39MGA-23	Spiralfeder MK2 De Luxe + Twin Cam	Front spring MK2 de Luxe + Twin Cam	2
VA41MGA-23	Querlenker-Arm rechts (Fahrzeug mit Stabi)	Wishbone arm front right hand (cars with front anti-roll bar)	1
VA42MGA-23	Querlenker-Arm links (Fahrzeug mit Stabi)	Wishbone arm front left hand (cars with front anti-roll bar)	1
	Umrüstsatz auf Koni-Stoßdämpfer vorne (ohne Dämpfer), mit TÜV-Gutachten:	Conversion kit for Koni shock absorbers (w/o absorber) - with TÜV approval:	
VA80MGA-T	MGA mit Trommelbremse	MGA with drum brakes	1
VA80MGA-S	MGA mit Scheibenbremse	MGA with disk brakes	1
VA80AMGB	Stoßdämpfer Koni für VA80MGA..	Koni shock absorber for conversion kit VA80MGA..	2



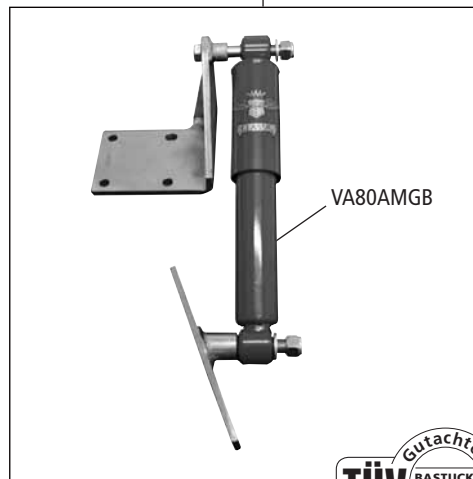
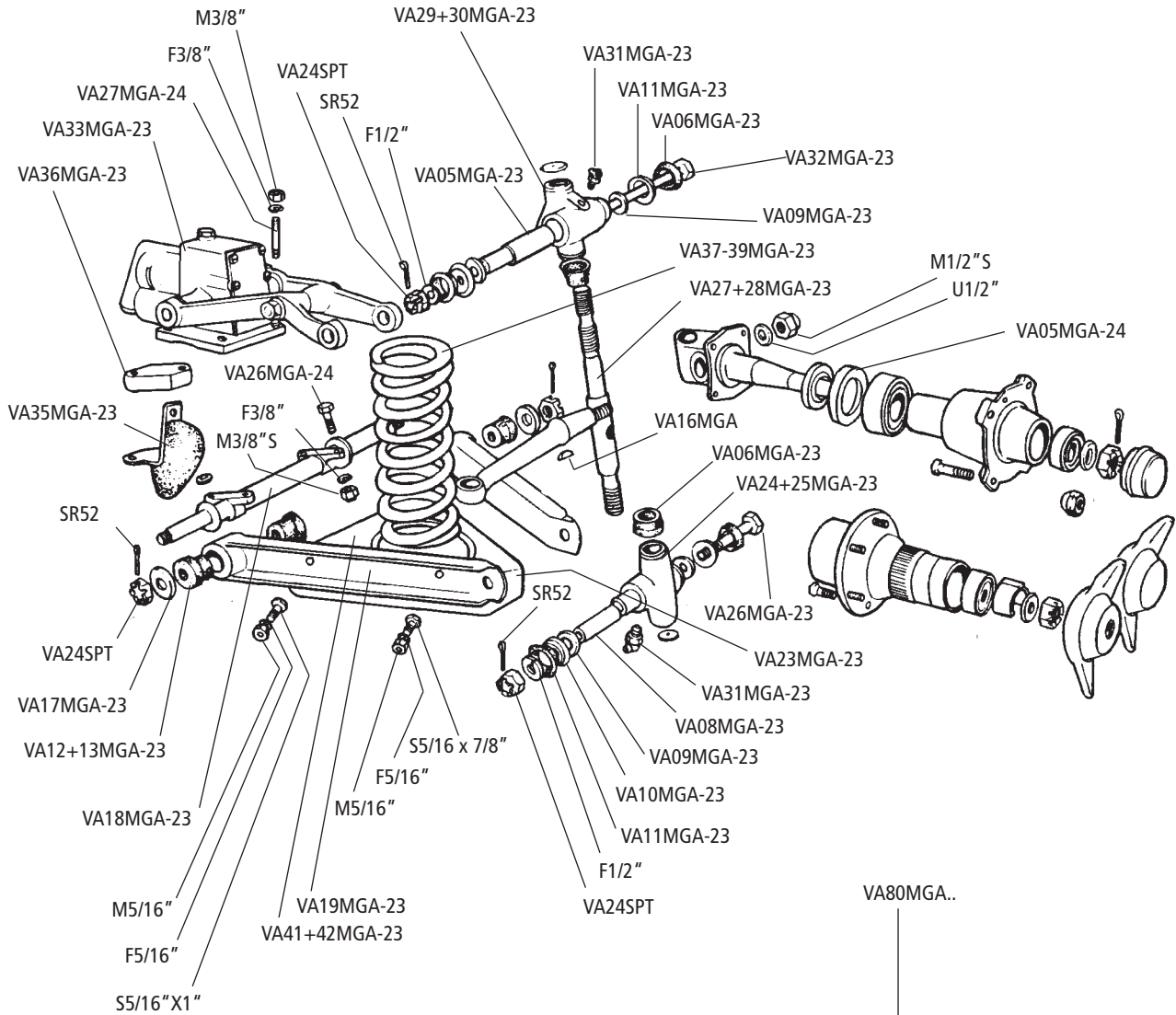

Hinweis 
Note:

Ausführliche Montageanleitungen zum Umrüstsatz VA80MGA im Internet: www.bastuck.com

Fitting instructions for conversion kit VA80MGA: www.bastuck.com

No.	Bezeichnung	Description	Anzahl/Qty.
VA01MGA-24	Radnabe vorne 1500 Stahlfelge/Trommelbremse	Front wheel hub 1500 steel wheel/drum brakes	2
VA02MGA-24	Radnabe vorne 1600 Stahlfelge bis 69504	Front wheel hub 1600 steel wheel up to 69504	2
VA03MGA-24	Radnabe vorne 1600 Stahlfelge ab 69505 + MK2	Front wheel hub 1600 steel wheel from 69505 + MK2	2
VA04MGA-24	Abstandshalter (außer MK2 De Luxe + Twin Cam)	Front wheel hub spacer (except MK2 de Luxe + Twin Cam)	2
VA05MGA-24	Simmerring (außer MK2 De Luxe + Twin Cam)	Oil seal front wheel hub (except MK2 de Luxe + Twin Cam)	2
VA06MGA-24	Radlager innen (außer MK2 De Luxe + Twin Cam)	Inner wheel bearing front hub (except MK2 de Luxe + Twin Cam)	2
VA07MGA-24	Radlager außen (außer MK2 De Luxe + Twin Cam)	Outer wheel bearing front hub (except MK2 de Luxe + Twin Cam)	2
VA08MGA-24	Abstandshalter (außer MK2 De Luxe + Twin Cam)	Front wheel hub spacer (except MK2 de Luxe + Twin Cam)	2
VA09MGA-24	Kronenmutter Rechtsgewinde	Crown nut right hand thread	1
VA10MGA-24	Kronenmutter Linksgewinde	Crown nut left hand thread	1
VA11MGA-24	Fettkappe Radnabe vorne Stahlfelge	Grease retaining cap front hub steel wheel	2
F12MGL	Speichenradnabe (Scheibenbremse) 1600/1622 rechts	Front wire wheel hub 1600/1622 right hand (disc brakes)	1
F12MGR	Speichenradnabe (Scheibenbremse) 1600/1622 links	Front wire wheel hub 1600/1622 left hand (disc brakes)	1
F13TR	Radmutter Stahlfelge	Wheel nut steel wheels	8
VA12MGA-24	Radbolzen Stahlfelge	Front wheel stud steel wheel	8
VA18MGA-24	Speichenradnabe (Trommelbremse) 1500 rechts	Front wire wheel hub 1500 right hand (drum brakes)	1
VA19MGA-24	Speichenradnabe (Trommelbremse) 1500 links	Front wire wheel hub 1500 left hand (drum brakes)	1
VA22MGA-24	Radbolzen 1500	Wheel stud 15001	12
VA23MGA-24	Bolzen Radnabe/Bremsscheibe	Bolt wheel hub/brake disc	8
VA24MGA-24	Fettkappe Speichenradflansch	Grease retaining cap front hub wire wheel	2
VA25MGA-24	Sicherungsscheibe	Lock washer	2
VA26MGA-24	Bolzen	Bolt	8
VA27MGA-24	Stehbolzen	Stud	8
HSD	Stoßdämpferöl, pro Liter	Shock absorber oil, per liter	A/R

Twin Cam + De Luxe

Twin Cam + De Luxe

ZK04MGA-09	Scheibe 5/8"	Washer, plain 5/8"	2
D13SPTMK4	Lager innen	Inner bearing	2
VA37MGB-18	Distanzteil Radlager	Spacer, bearing	2
VA38MGB-18	Satz Ausgleichsscheiben	Shim set	A/R
VA39MGB-18	Sicherungsscheibe Radlager	Washer, retaining	2
VA40MGB-18	Lager-Sicherungsmutter	Bearing lock nut	2
D44MGA-26	Simmerring	Oil seal	2
VA46MGB-18	Fettkappe	Grease retaining cap	2
VA105AH	Lager außen	Outer bearing	2

Hinweis 
Note:Anmerkung zu Nr. F12MGL/R:
nicht für MK2 De Luxe + Twin Cam!Note to no. F12MGL/R:
Except MK2 De Luxe + Twin Cam**Hinweis** 
Note:Anmerkung: Umrüstung auf Speichenräder,
vorne wie hinten, ohne Änderung der Radnaben!
– siehe Seite 55!Note: Converting from steel to wire wheels, front or rear,
without changing the wheel hubs! See page 55!

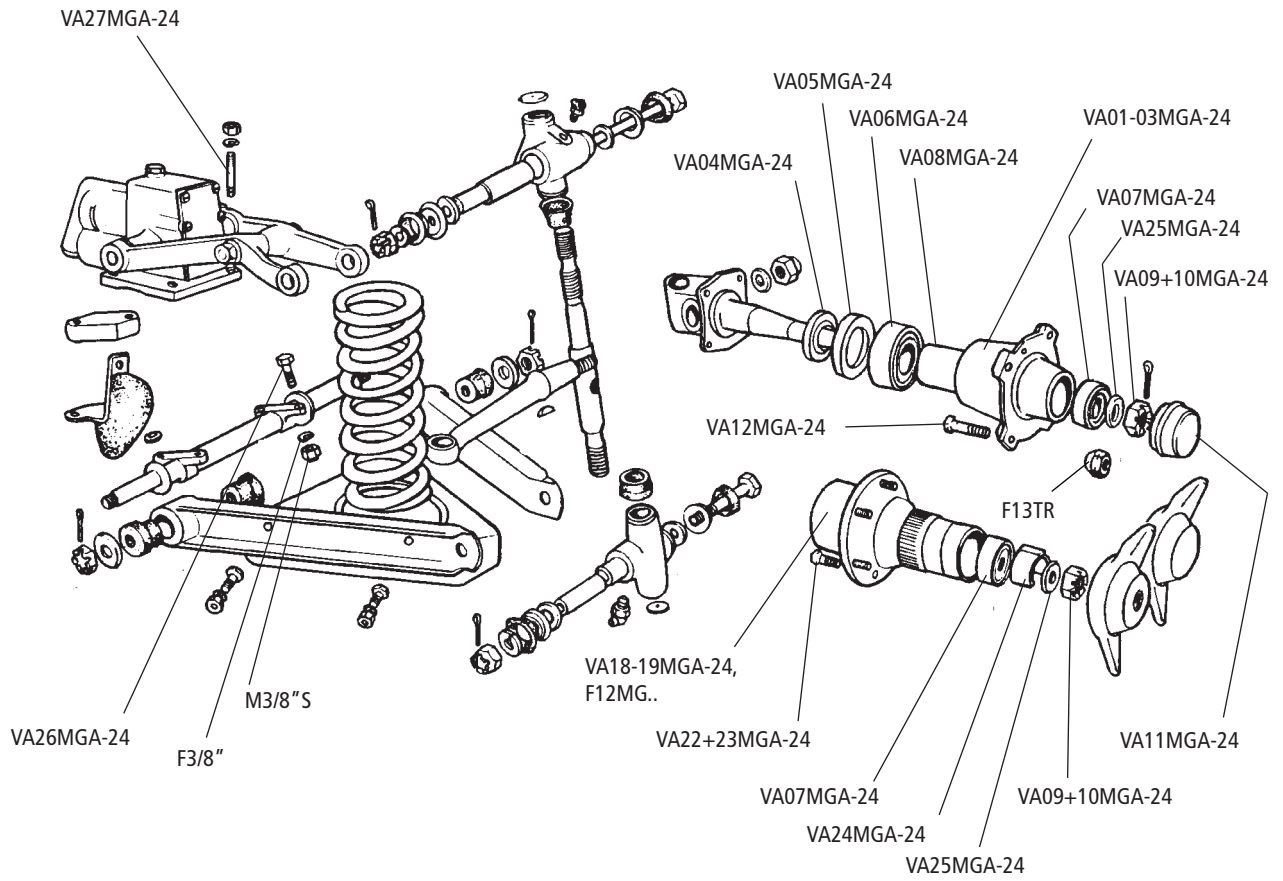

Twin Cam + De Luxe

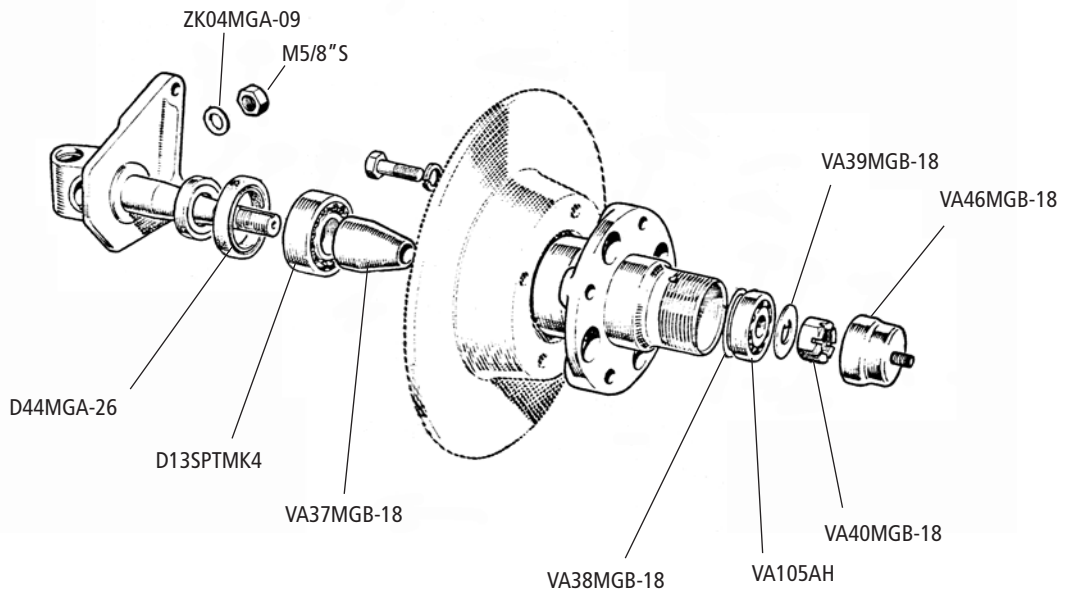

No.	Bezeichnung	Description	Anzahl/Qty.
L01MGA-27	Austauschlenkung Linkslenker	Exchange steering rack lhd	1
L01MGA/TC	Austauschlenkung Twin Cam + De Luxe Linkslenker	Exchange steering rack Twin CAM + De Luxe lhd	1
L02MGA-27	Simmerring Lenkritzel	Pinion oil seal	1
L03MGA-27	Kreuzgelenk Lenkung	Universal joint steering	1
L05MGA-27	Befestigungsbolzen Kreuzgelenk	Bolt universal joint steering	2
M5/16"	Mutter	Nut	2
L07MGA-27	Spurstangenkopf komplett	Track rod end	2
L09MGA-27	Kontermutter Spurstangenkopf/Spurstange	Nut track rod end/track rod	2
L10MGA-27	Ausgleichscheibe 0.003"	Shim 0.003"	A/R
L11MGA-27	Ausgleichscheibe 0.005"	Shim 0.005"	A/R
L12MGA-27	Ausgleichscheibe 0.010"	Shim 0.010"	A/R
L13MGA-27	Lenkmanschette	Rack seal	2
L14MGA-27	Dichtung Lenksäule und Abdichtplatte	Seal steering column and blanking plate	2
L15MGA-27	Filzlager unten	Felt bush, lower	1
L16MGA-27	Filzlager oben verstellbare Lenksäule	Felt bush, upper adjustable steering column	1
L17MGA-27	Filzlager oben nicht verstellbare Lenksäule	Felt bush, upper fixed steering column	1
L18MGA-27	Schelle Lenksäule	Clamp column	2
L19MGA-27	Chrome-Klammer verstellbare Lenksäule	Steering clamp chrome adjustable steering column	1
L20MGA-27	Chrom Spiralfeder verstellbare Lenksäule	Spring, adjustable steering column	1
L21MGA-27	Abdeckkappe Spiralfeder verstellbare Lenksäule	Cap spring, adjustable steering column	1
L22MGA-27	"Original"-Lenkrad	Original steering wheel	1
L23MGA-27	Mittelteil „Original“-Lenkrad	Steering wheel centre	1
L24MGA-27	Holzlenkrad Original Zubehör	Steering wheel, wood, original accessory	1
S13ASPT	Befestigungsklammer Mittelteil Lenkrad	Clip	4
L25MGA-27	Mutter Lenkrad/Lenksäule	Steering wheel nut	1
L26MGA-27	Schelle Klein	Clip small	2
VA31MGA-23	Schmiernippel	Grease nipple	2
L29MGA-27	Sicherungsring Spurstange	Tie rod lock washer	2
L30MGA-27	Schelle	Clip large	2
L31MGA-27	Ausgleichscheibe Lenkung an Halterung	Shim steering rack to mounting brackets	A/R
L35MGA	Welle oben für einstellbare Lenksäule	Shaft for adjustable column	1
L99MGA	Stabilisator-Kit ab Fg.Nr. 66574	Anti roll bar kit, from chassis no. 66574	1

Hinweis
Note:



Anmerkung: „Sport-Lenkräder (Holz oder Leder)
siehe Seite 52!

Note: Sport steering wheels - wooden and leather
see page 52!

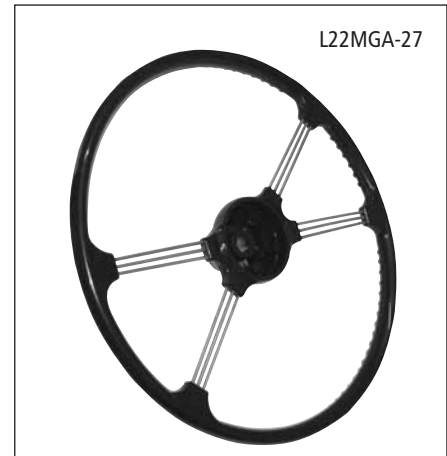
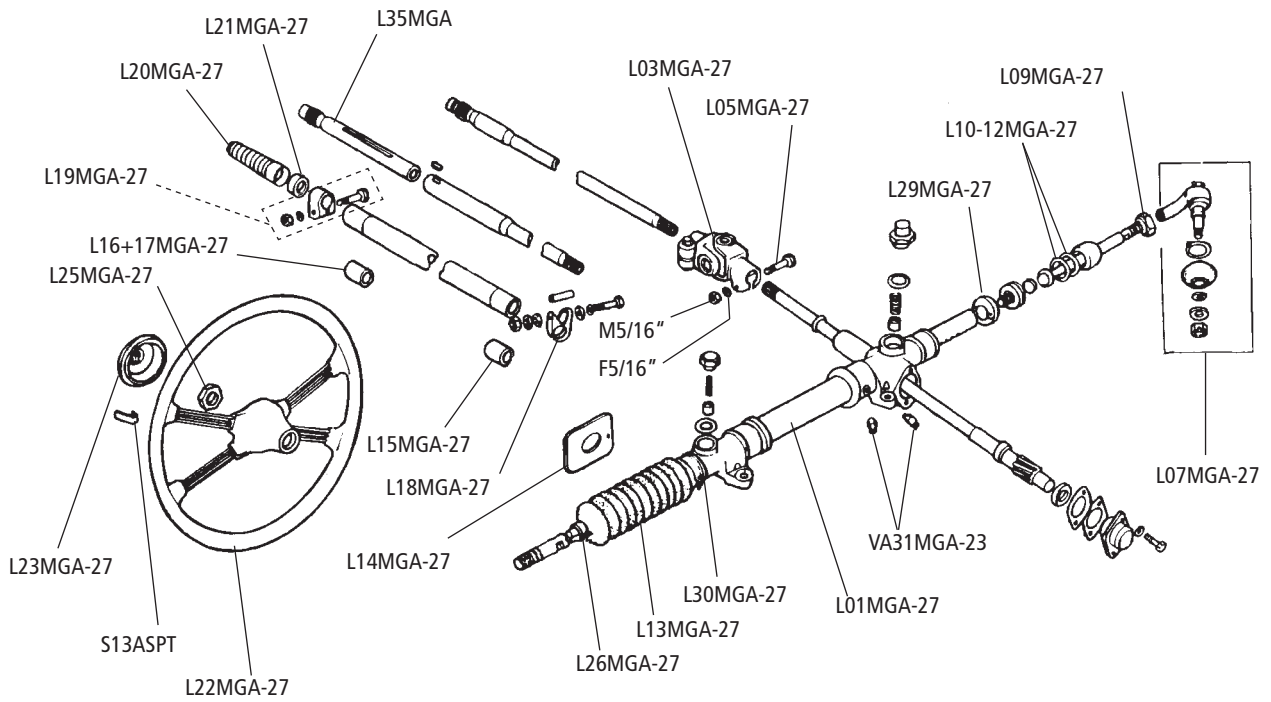

Sportlenkräder ohne ABE

Sport steering wheels w/o homologation

No.	Bezeichnung	Description	Anzahl/Qty.
L100TR	Lenkrad 13" Leder - gelocht, geschüsselt	Steering wheel 13" leather - drilled, bowl form	1
L101TR	Lenkrad 13" Leder - gelocht, flach	Steering wheel 13" leather - drilled, plain	1
L102TR	Lenkrad 13" Leder - gerautet, geschüsselt	Steering wheel 13" leather - riveted, bowl form	1
L103TR	Lenkrad 13" Leder - gerautet, flach	Steering wheel 13" leather - riveted, plain	1
L110TR	Lenkrad 14" Leder - gelocht, geschüsselt	Steering wheel 14" leather - drilled, bowl form	1
L111TR	Lenkrad 14" Leder - gelocht, flach	Steering wheel 14" leather - drilled, plain	1
L112TR	Lenkrad 14" Leder - gerautet, geschüsselt	Steering wheel 14" leather - riveted, bowl form	1
L113TR	Lenkrad 14" Leder - gerautet, flach	Steering wheel 14" leather - riveted, plain	1
L120TR	Lenkrad 15" Leder - gelocht, geschüsselt	Steering wheel 15" leather - drilled, bowl form	1
L121TR	Lenkrad 15" Leder - gelocht, flach	Steering wheel 15" leather - drilled, plain	1
L122TR	Lenkrad 15" Leder - gerautet, geschüsselt	Steering wheel 15" leather - riveted, bowl form	1
L123TR	Lenkrad 15" Leder - gerautet, flach	Steering wheel 15" leather - riveted, plain	1
L130TR	Lenkrad 13" Holz - gelocht, geschüsselt	Steering wheel 13" wood - drilled, bowl form	1
L131TR	Lenkrad 13" Holz - gelocht, flach	Steering wheel 13" wood - drilled, plain	1
L132TR	Lenkrad 13" Holz - gerautet, geschüsselt	Steering wheel 13" wood - riveted, bowl form	1
L133TR	Lenkrad 13" Holz - gerautet, flach	Steering wheel 13" wood - riveted, plain	1
L140TR	Lenkrad 14" Holz - gelocht, geschüsselt	Steering wheel 14" wood - drilled, bowl form	1
L141TR	Lenkrad 14" Holz - gelocht, flach	Steering wheel 14" wood - drilled, plain	1
L142TR	Lenkrad 14" Holz - gerautet, geschüsselt	Steering wheel 14" wood - riveted, bowl form	1
L143TR	Lenkrad 14" Holz - gerautet, flach	Steering wheel 14" wood - riveted, plain	1
L150TR	Lenkrad 15" Holz - gelocht, geschüsselt	Steering wheel 15" wood - drilled, bowl form	1
L151TR	Lenkrad 15" Holz - gelocht, flach	Steering wheel 15" wood - drilled, plain	1
L152TR	Lenkrad 15" Holz - gerautet, geschüsselt	Steering wheel 15" wood - riveted, bowl form	1
L153TR	Lenkrad 15" Holz - gerautet, flach	Steering wheel 15" wood - riveted, plain	1
L160TR	Lenkrad 14" Vollholz, ohne Nieten - Speichen silberfarben, geschüsselt	Steering wheel 14" wood - drilled, without rivets - spokes silver, bowl form	1 1
L170TR	Lenkrad 15" Holz - 4 Speichen, flach	Steering wheel 15" wood - riveted, 4 spokes, plain	1
L80aMGA/H	Adapter für Sportlenkrad	Adaptor for sport steering wheel	1

**Adapter auch für weitere Fahrzeugtypen
lieferbar - bitte fragen Sie nach !**

**Adaptors also available for
other cars - please enquire !**



Schema: Lenkrad flach
Scheme: steering wheel plain

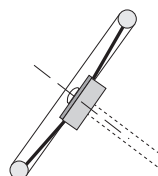

Schema: Lenkrad geschüsselt
Scheme: steering wheel bowl
form

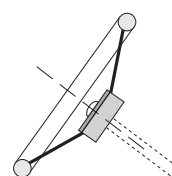



Beispiel: Lenkrad Holz - gelocht
Example: Steering wheel wood - drilled



Beispiel: Lenkrad Leder - gelocht
Example: Steering wheel leather - drilled



Beispiel: Lenkrad Vollholz - gerautet, ohne Nieten
Example: Steering wheel wood - without rivets



Beispiel: Lenkrad Holz - 4 Speichen
Example: Steering wheel wood - 4 spokes

Innenausstattungsteile finden
Sie ab Seite 86.

Interior trim and fittings -
see page 86 ff.



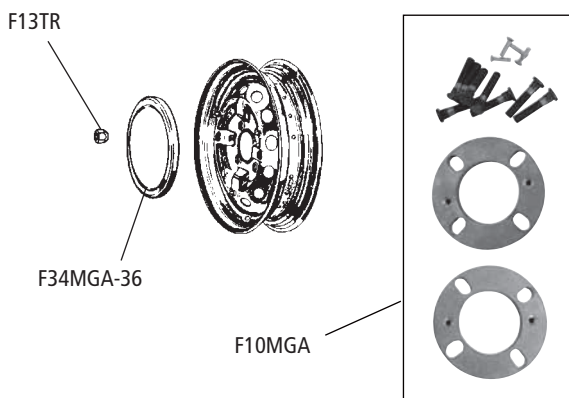

Speichenfelge / Wire Wheel

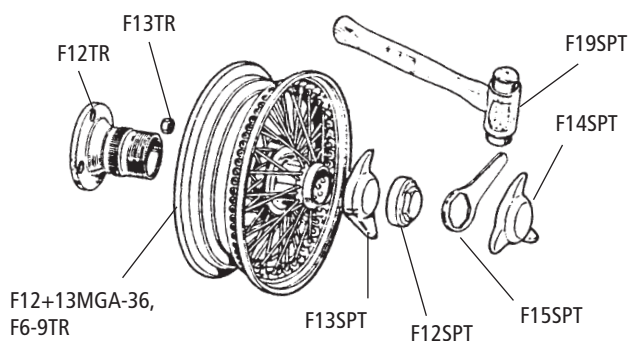

Minilite-Felge / Minilite wheel

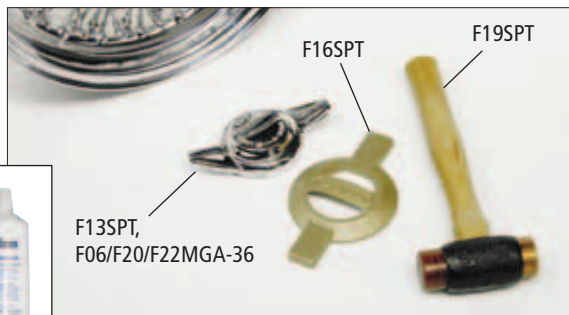
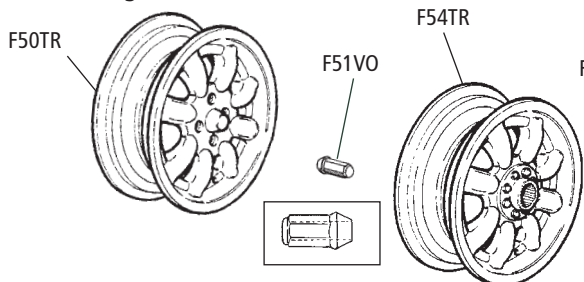

F12SPT, F04aMGA-36, F18MGA-36, F18aMGA-36

F13SPT, F06a(07a)MGA-36, F20(21)MGA-36, F22(23)MGA-36

F14SPT, F24(25)MGA-36



Rüsten Sie Ihren MGA einfach, problemlos und kosten- günstig auf Speichenräder um (ohne Änderung der Radnaben und Steckachsen)!

Convert your MGA from steel wheels to wire wheels, without changing the standard wheel hubs (just a easy bolt on)!

Hinweis  **Note:**

Alle Chromspeichenräder jetzt mit Edelstahl- speichen. Wir gewähren **2 Jahre Garantie** auf alle Speichenräder.

The wire wheels are equipped with stainless steel spokes. All our wire wheels with 2 years-guarantee.

Einzelne Speichen auf Anfrage / Single spokes on demand

No.	Bezeichnung	Description	Anzahl/Qty.
Speichenräder		Wire wheels	
F12MGA-36	Speichenrad 4 x 15" Chrom (48 Speichen)	Wire wheel 4 x 15" chrome (48 spokes)	A/R
F13MGA-36	Speichenrad 4 x 15" Lackiert (48 Speichen)	Wire wheel 4 x 15" painted (48 spokes)	A/R
F6TR	Speichenrad 4 1/2 x 15" Chrom (60 Speichen)	Wire wheel 4 1/2 x 15" chrome (60 spokes)	A/R
F7TR	Speichenrad 4 1/2 x 15" Lackiert (60 Speichen)	Wire wheel 4 1/2 x 15" painted (60 spokes)	A/R
F8TR	Speichenrad 5 1/2 x 15" Chrom (72 Speichen)	Wire wheel 5 1/2 x 15" chrome (72 spokes)	A/R
F9TR	Speichenrad 5 1/2 x 15" Lackiert (72 Speichen)	Wire wheel 5 1/2 x 15" painted (72 spokes)	A/R
Umrüstsätze auf Speichenräder ²⁾		Conversion kit to wire wheels ²⁾	
F1MGA	Umrüstsatz inkl. Felgen 4"x 15" chrom	Conversion kit incl. wire wheels 4"x 15" chrome	1
F2MGA	Umrüstsatz inkl. Felgen 4 1/2"x 15" chrom	Conversion kit incl. wire wheels 4 1/2"x 15" chrome	1
F3MGA	Umrüstsatz inkl. Felgen 5 1/2"x 15" chrom	Conversion kit incl. wire wheels 5 1/2"x 15" chrome	1
F12MGR	Adapter vorne 12tpi ¹⁾	Wire wheel hub front 12tpi ¹⁾	1
F12AMG	Adapter hinten 12tpi ¹⁾	Wire wheel hub rear 12tpi ¹⁾	1
Speichenradzubehör 8tpi *		Wire wheel Accessories 8tpi *	
F10MGA	Adapter-Satz Vorderachse MGA zum Umrüsten von Stahl- auf Speichenräder bei Verwendung von F12TR ³⁾	Wire wheel hub set front suspension MGA to convert from steel to wire wheels when using F12TR.. ³⁾	1
F12TR	Speichenradadapter vorne/hinten 8tpi ^{1) 3)}	Wire wheel hub front/rear ^{1) 3)}	2
F13TR	Adapter-Befestigungsmutter	Extension hub nut	16
F12SPT	Achtkant-Zentralverschluß 8tpi ¹⁾	Octagon wheel nut 8tpi ¹⁾	2
F04AMGA-36	Achtkant-Zentralverschluß 8tpi -MG-Zeichen ¹⁾	Octagon wheel nut 8tpi -MG-logo ¹⁾	2
F13SPT	2-Zackige Flügelmutter 8tpi ¹⁾	2-eared wheel nut 8tpi ¹⁾	2
F06AMGA-36	2-Zackige Flügelmutter 8tpi rechts -MG-Zeichen	2-eared wheel nut 8tpi right hand -MG-logo	2
F07AMGA-36	2-Zackige Flügelmutter 8tpi links -MG-Zeichen	2-eared wheel nut 8tpi left hand -MG-logo	2
F14SPT	3-Zackige Flügelmutter 8tpi ¹⁾	3-eared wheel nut 8tpi ¹⁾	2
Speichenradzubehör 12tpi *		Wire wheel Accessories 12tpi *	
F18MGA-36	Achtkant-Zentralverschluß 12tpi rechts	Octagon wheel nut 12tpi right hand	2
F18AMGA-36	Achtkant-Zentralverschluß 12tpi links	Octagon wheel nut 12tpi left hand	2
F19MGA-36	Achtkant-Zentralverschluß 12tpi rechts -MG-Zeichen	Octagon wheel nut 12tpi right hand -MG-logo	2
F19AMGA-36	Achtkant-Zentralverschluß 12tpi links -MG-Zeichen	Octagon wheel nut 12tpi left hand -MG-logo	2
F20MGA-36	2-Zackige Flügelmutter 12tpi rechts -MG-Zeichen	2-eared wheel nut 12tpi right hand -MG-logo	2
F21MGA-36	2-Zackige Flügelmutter 12tpi links -MG-Zeichen	2-eared wheel nut 12tpi left hand -MG-logo	2
F22MGA-36	2-Zackige Flügelmutter 12tpi rechts	2-eared wheel nut 12tpi right hand	2
F23MGA-36	2-Zackige Flügelmutter 12tpi links	2-eared wheel nut 12tpi left hand	2
F24MGA-36	3-Zackige Flügelmutter 12tpi rechts	3-eared wheel nut 12tpi right hand	2
F25MGA-36	3-Zackige Flügelmutter 12tpi links	3-eared wheel nut 12tpi left hand	2
Minilite-Felgen		Minilite wheel	
F54TR	Minilite-Style-Alu-Felge 5 1/2 X 15" Zentralverschluß	Minilite-style wheel 5 1/2 x 15" centre lock	A/R
F50TR	Minilite-Style-Alu-Felge 5 1/2 X 15"	Minilite-style wheel 5 1/2 x 15"	A/R
F51VO	Minilite-Style-Radmutter (zu Felge F50TR)	Wheel nut „Minilite-style“ (wheel no. F50TR)	16
F13TR	Radmutter Stahlfelge	Wheel nut steel wheels	16
F15SPT	Schlüssel für Achtkant-Zentralverschluß	Octagon wheel nut spanner	1
F17SPT	Steckschlüssel Alu eloxiert für 8-Kant Mtter	Aluminium socket wheel, octagon wheel nut	1
F18SPT	Steckschlüssel für 2-Zack Flügelmutter	Socket wheel, 2-eared spinner	1
F19SPT	Kupfer-, Leder- Hammer	Copper hide hammer	1
F15SPT	Schlüssel für Achtkant-Zentralverschluß	Octagon wheel nut spanner	1
F15AH	Speichenfelge Reinigungsbürste	Wire wheel cleaning brush	1
F16AH	Einstell-Schlüssel Speichenradnippel	Wire wheel spoke wrench	1
F16SPT	Speichenradschlüssel Messing	Octagon wheel nut spanner brass	1
F30SPT	Kupferpaste für Speichenradadapter 90 g	Copper lubrication for splines, 90 g	1
F34MGA-36	Radkappe Stahlfelge	Hub cap steel wheel	4

¹⁾ Bitte Seite angeben (links oder rechts)

²⁾ Umrüstsatz = 4x Felge + 4x Adapter, 4x Acht-Kant-Mutter, 16 x Befestigungsschrauben, 1x Adaptersatz Vorderachse (F10MGA)

³⁾ Fahrzeuge mit Trommelbremse vorne

¹⁾ Please refer side (left or right hand)

²⁾ Conversion kit = 4x wire wheel + 4x hub, 4x continental wheel nut, 16x extension hub nut, 1x wire wheel kit front suspension (no. F10MGA)

³⁾ Cars equipped with front drum brakes

Hinweis 

* 8tpi = Grobgewinde Nachrüstspeichenräder
12tpi = Feingewinde für Fahrzeuge mit serienmäßigen Speichenrädern

* 8tpi = MGA converted to wire wheels
12tpi = all MGA original equipped with wire wheels

Bremsattel- u. schein

Brake callipers & brake discs

No.	Bezeichnung	Description	Anzahl/Qty.
B1CTR2R	Radbremszylinder vorne rechts	Front wheel cylinder right hand	2
B1CTR2L	Radbremszylinder vorne links	Front wheel cylinder left hand	2
B01MGA-21	Bremstrommel hinten (alle) / vorne (1500 Stahlfelgen)	Brake drum rear (all) / front (1500 with steel wheels)	2/4
B3TR2000	Reparatursatz Bremszange	Repair kit front calliper	1
B04MGA-21	Satz Bremsbacken hinten (4 tlg)	Set brake shoes rear (4 pcs)	1/2
M7/16"	Befestigungsmutter hinten 1500/1600 (Speichenfelgen)	Nut rear wire wheel hub 1500/1660 (wire wheels)	8
B06MGA-21	Sicherungsblech	Lock tab wire wheel brake drum	4/8
SR7	Senkkopfschraube Bremstrommel	Countersunk-screw brake drum	4
B09MGA-21	Rückholfeder Bremsbacken „dick“	Spring, brake return „thick“	4
B10SPT	Bolzen Ankerplatte hinten	Lever dust cover handbrake lever	8
B13MGA-21	Gummi Handbremshebel	Bolt backplate rear	2
B14MGA-21	Halter Bremseinsteller	Mask micram adjuster	4
B16MGA-21	Entlüftungsnippel 1500 bis 27898 (Stahlfelgen) bis 28540 (Speichenfelgen)	Bleed nipple 1500 up to 27898 (steel wheels) 1500 up to 28540 (wire wheels)	4
B19MGA-21	Banjo-Schraube 1500 ab 27900 (Stahlfelgen) 1500 ab 28541 (Speichenfelgen)	2-way union 1500 from 27899 (steel wheels) 1500 from 28541 (wire wheels)	4
B20TR2	Haltefeder Bremsbacke	Spring brake shoe steady	4
B20MGA-21	Hohlschraube	Bolt banjo	2
B21MGA-21	Bremstrommel vorne 1500 (Speichenfelgen)	Brake drum front 1500 (wire wheels)	2
B22MGA-21	Sicherungsblech	Tab drum to wire wheel hub	6
B22TR2	Einstellexenter	Micram adjuster wheel cylinder	2
B23MGA-21	Stopfen Bremstrommel 1/2"	Plug rear brake inspection 1/2"	A/R
B24MGA-21	Stopfen Bremstrommel 3/4"	Plug rear brake inspection 3/4"	A/R
B24TR2	Bremsbackenauflegebock	Block abutment	2
B26BTR	Radbremszylinder	Rear wheel cylinder	2
B26CTR	Reparatursatz Radzylinder	Repair kit rear wheel cylinder	2
B27SPT	Entlüftungsnippel 1500 ab 27900 (Stahlfelgen) ab 28541 (Speichenfelgen)	Bleed nipple 1500 from 27899 (steel wheels) 1500 from 28541 (wire wheels)	4
B28MGA-21	Reparatursatz Radbremszylinder	Repair kit front wheel cylinder	4
B30TR2	Banjo-Schraube 1500 bis 27898 (Stahlfelgen) 1500 bis 28540 (Speichenfelgen)	2-way union 1500 up to 27898 (steel wheels) 1500 up to 28540 (wire wheels)	2
B30MGA-21	Bremsscheibe	Brake disc	2
B31MGA-21	Satz Bremsklötze (4 tlg)	Brake pad set (4 pcs)	1
B33MGA-21	Bremszangen-Kolben	Calliper piston	4
B35MGA-21	Bremssattel rechts, neu	Calliper right hand, new	1
B36MGA-21	Bremssattel links, neu	Calliper left hand, new	1
B38MGA-21	Befestigungsbolzen Bremszange	Calliper mounting bolt	4/2
B39MGA-21	Sicherungsblech rechts	Calliper lock plate, right hand	1
B40MGA-21	Sicherungsblech links	Calliper lock plate, left hand	1
B40TR3	Rückholfeder Bremsbacken „dünn“	Spring, abutment end „thin“	2
B41MGA-21	stopfen Bremstrommel 3/4"	Plug front brake inspection 3/4"	A/R
B42MGA-21	Stopfen Bremstrommel 1/2"	Plug front brake inspection 1/2"	A/R
B43MGA-21	Haltestifte Bremsklötze	Locating pin	2
B44MGA-21	Halteklammer Bremsklötze	Clip pad retaining	2
B45MGA-21	Bolzen Ankerplatte vorne	Bolt backplate front	8
B47MGA-21	Hebel Handbremse	Lever handbrake	2
B100MGA1500	Umrüstung auf Scheibenbremse – Radnaben mit Radlager müssen erneuert werden * Radnaben Speichenräder: Art.Nr. F12MGL/R Radnaben Stahlräder: Art.Nr. VA02MGA-24	Conversion kit to front disc brake – wheel hub and wheel bearing have to be renewed * Wheel hub wire wheels: part no. F12MGL/R Wheel hub steel wheels: part no. VA02MGA-24	1
B100aMGA1500	Paar Adapter für MGB Sättel	Adaptors pair for MGB callipers	1
WZ101	Einstellschlüssel für Einstellexzenter Bremse	Tool for wheel cylinder adjuster	1

Hinweis 

Note:

* Radnaben finden Sie auf Seite 48!

* Wheel hubs: please refer page 48!



B100MGA1500



hinten / rear

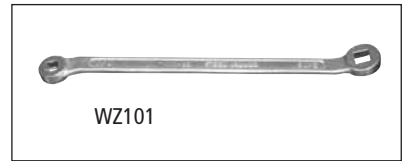
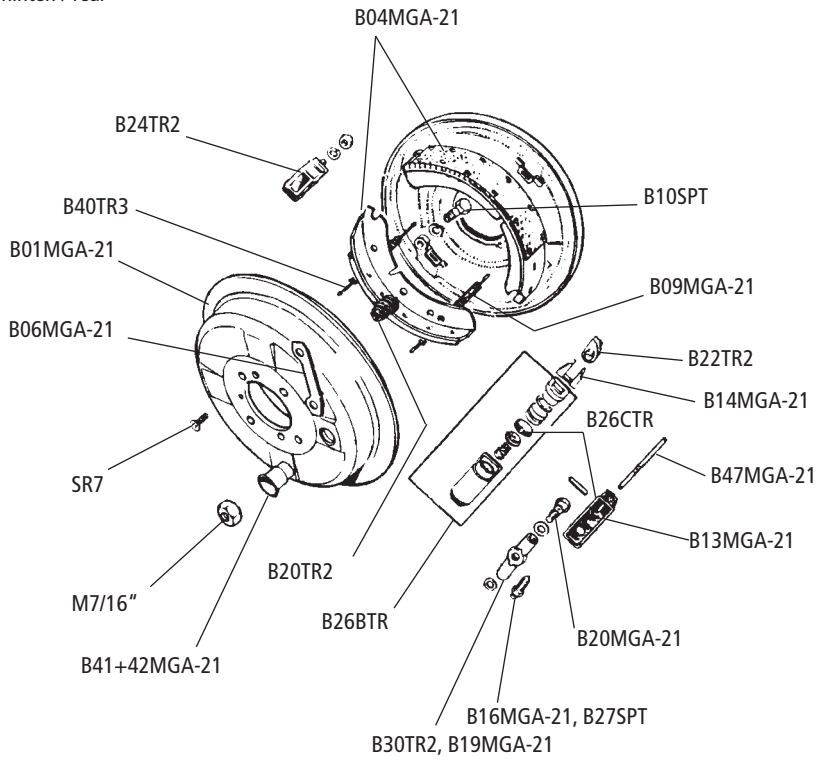

vorne / front 1500

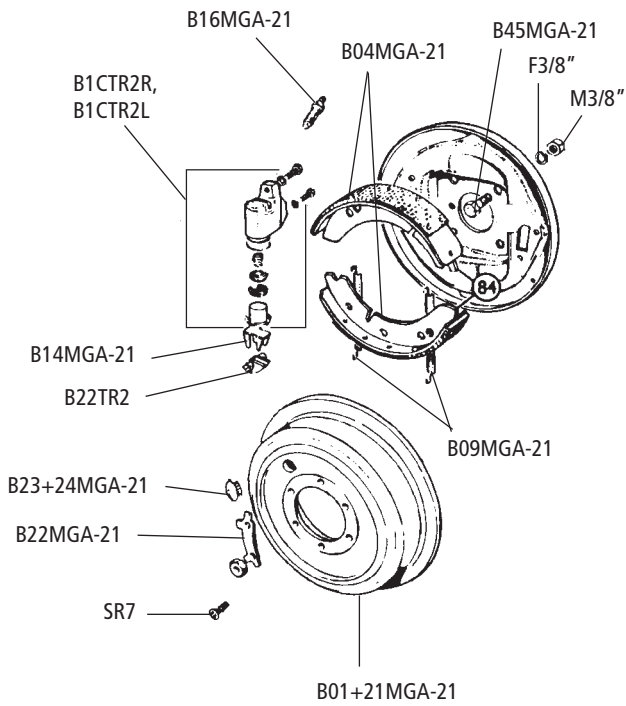

vorne / front 1600 & MK2

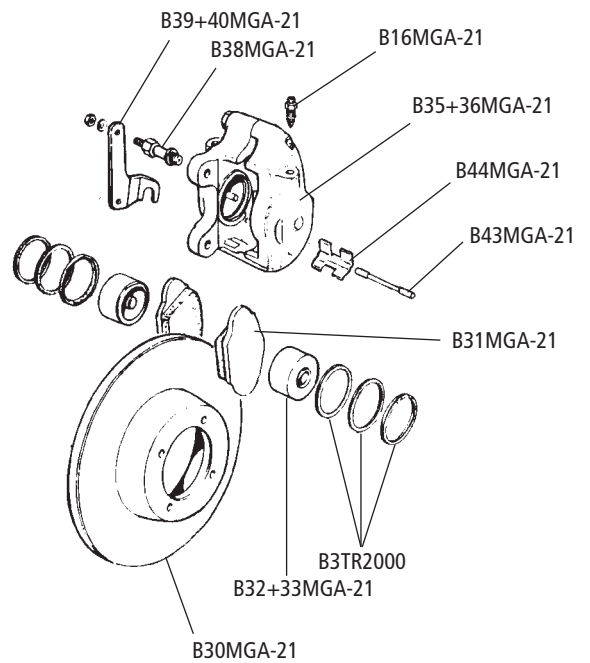

Bremse vorne (Twin Cam & De Luxe)

Front brakes (Twin Cam & De Luxe)

No.	Bezeichnung	Description	Anzahl/Qty.
B01MGA/TCL	AT-Bremssattel vorne links	Exchange caliper front lh	1
B01MGA/TCR	AT-Bremssattel vorne rechts	Exchange caliper front rh	1
B02MGA/TC	Bremsscheibe	Brake disc	2
B2JA/E3.8	Kolben/Zylinder Bremszange vorne	Cylinder and piston front	4
B03MGA/TC	Schraube für Bremsscheibe	Disc bolt	8
B3JA/E	Rep.-Satz Kolben/Zylinder vorne	Seals kit cylinder and piston front	1
B05MGA/TCL	Halter für Bremsschlauch links	Bracket brake hose lh	1
B05MGA/TCR	Halter für Bremsschlauch rechts	Bracket brake hose rh	1
B5JA/E	Satz Bremsbeläge	Pad set	1
B6AJA/E	Halteplatte Bremsbeläge	Keep plate	4
B6BJA/E	Halteplatte Bremsbeläge	Keep plate	4
B9JA/E	Entlüftungsschraube und Kugel	Brake bleed	2
B11JA/E3.8	Schraube Bremssattel	Bolt caliper	16
B30MGA/TC	Bremsleitung	Brake pipe	1
B31MGA/TC	Schraube Bremssattel	Bolt caliper	4

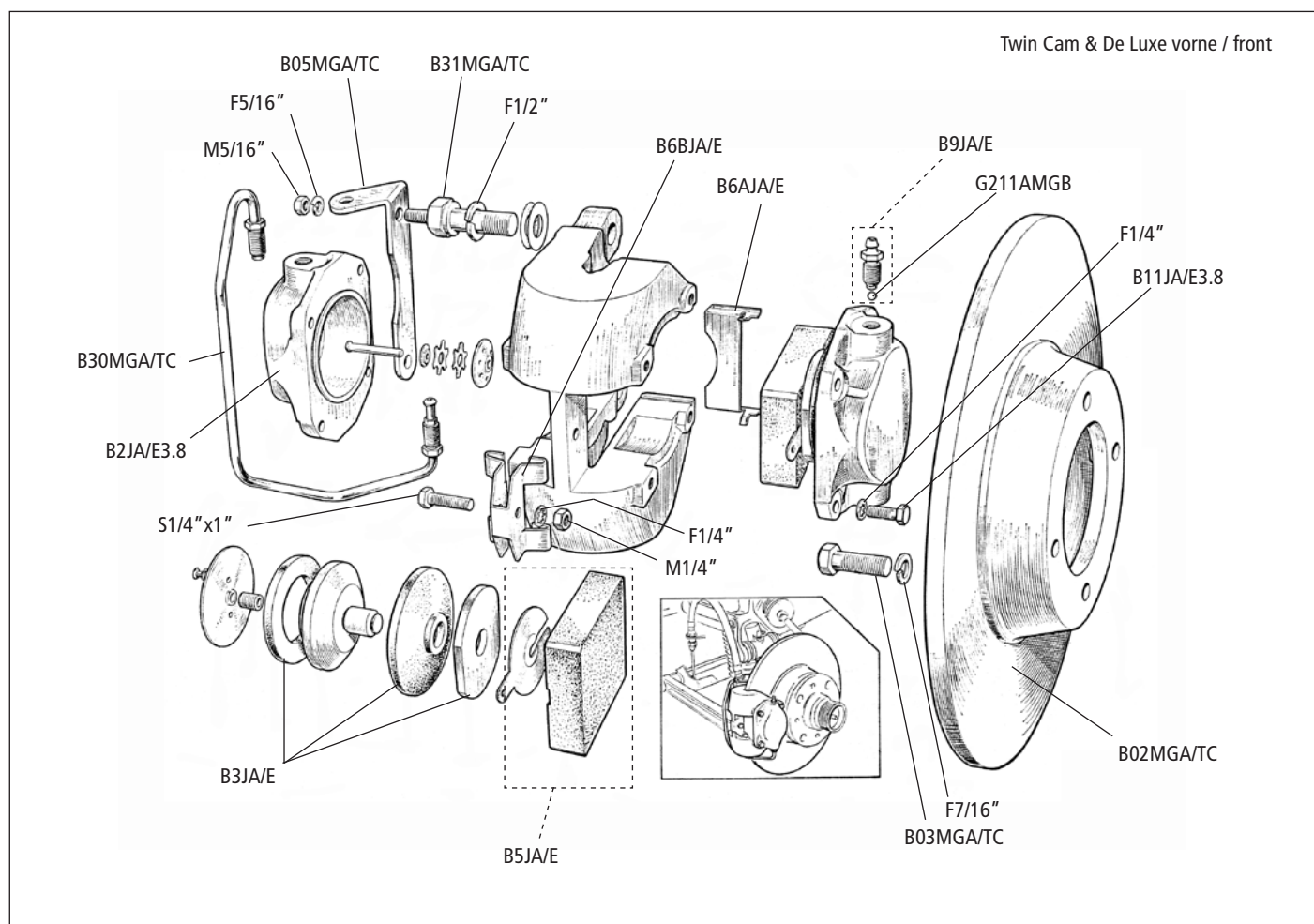

Bremse hinten (Twin Cam & De Luxe)

Rear brakes (Twin Cam & De Luxe)

No.	Bezeichnung	Description	Anzahl/Qty.
B40MGA/TCL	AT-Bremssattel hinten links	Exchange caliper rear lh	1
B40MGA/TCR	AT-Bremssattel hinten rechts	Exchange caliper rear rh	1
B03MGA/TC	Schraube für Bremsscheibe	Disc bolt	8
B5JA/E	Satz Bremsbeläge	Pad set	1
B6BJA/E	Halteplatte Bremsbeläge	Keep plate	4
B6AJA/E	Halteplatte Bremsbeläge	Keep plate	2
B9JA/E	Entlüftungsschraube und Kugel	Brake bleed	2
B11JA/E/3.8	Schraube Bremssattel	Bolt caliper	16
B22JA/MK2	Kolben/Zylinder Bremszange hinten	Piston & cylinder rear	4
B22AJA/MK2	Reparatursatz.-Satz Kolben/Zylinder	Seals kit cylinder and piston rear	1
B30MGA/TC	Bremsleitung	Brake pipe	1
HA33MGA-25	Mutter UNF 5/16"	Nut 5/16" UNF	2
B41MGA/TC	Bremsscheibe hinten	Brake disc rear	2
B42MGA/TC	Mutter 3/8"	Nut 3/8"	8
B45JA/E	Bolzen Handbremsattel-Befestigung	Pivot handbrake pad	4
B62MGA/TC	Sicherungsblech	Lock plate	2
B66MGA/TC	Befestigungssatz Handbremse	Assembly kit handbrake	1
B69MGA/TC	Einstellschraube	Bolt	2
B70SPT	Bolzen	Clevis pin	2
G211AMGB	Kugel 3/16"	Ballbearing 3/16"	2
B131JA/XK150	Sicherungsbolzen Handbremsattel	Locktab brake	2

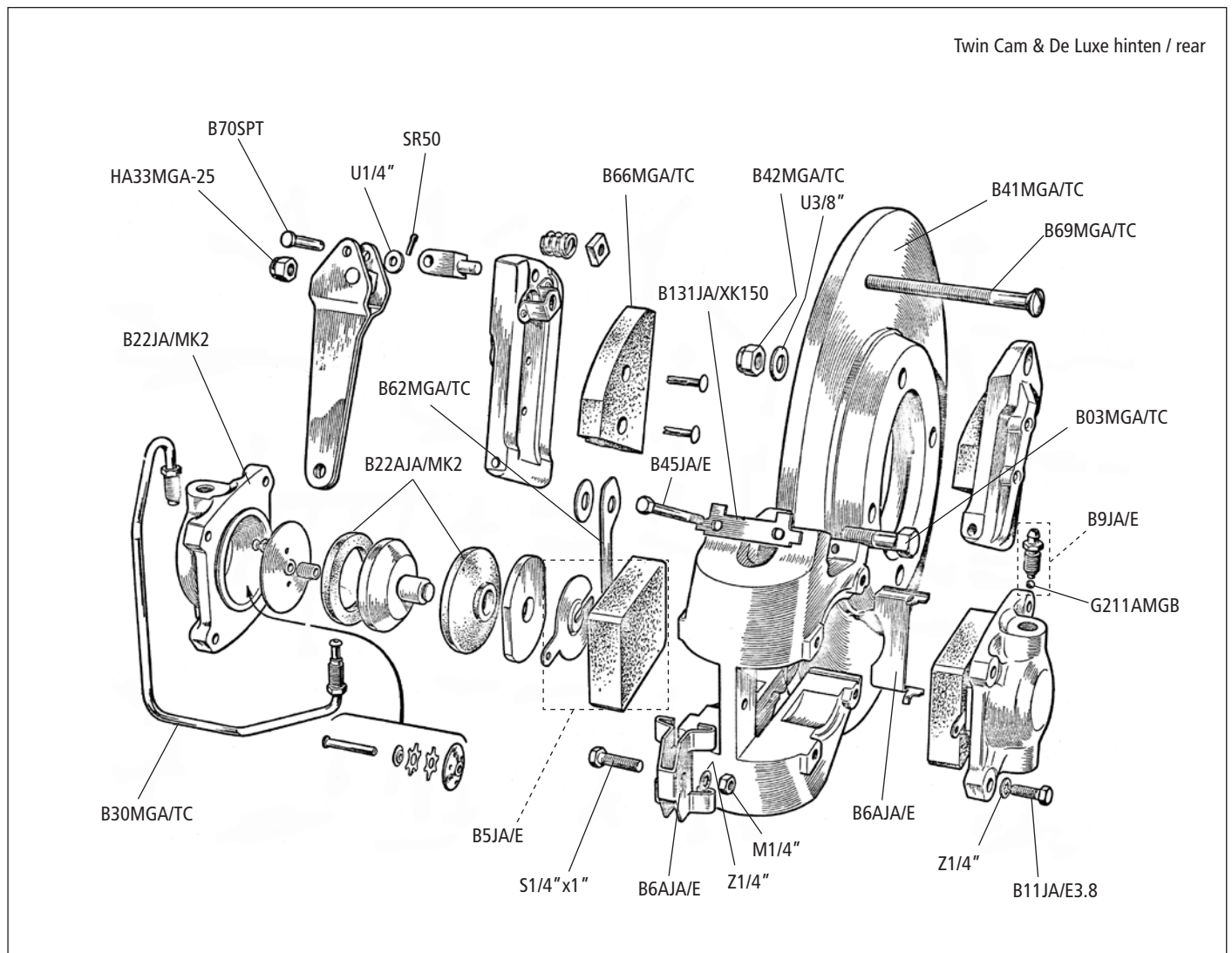

Bremsleitungen

Brake pipes

No.	Bezeichnung	Description	Anzahl/Qty.
B01MGA-22	Bremsleitungssatz 1500 Lhd ¹⁾	Brake pipe set 1500 lhd ¹⁾	1
B05MGA-22	Bremsleitungssatz 1600 + MK2 Lhd ¹⁾	Brake pipe set 1600 + MK2 lhd ¹⁾	1
B06MGA/TC	Bremsleitungssatz Twin Cam + De Luxe ¹⁾	Brake pipe set Twin Cam + De Luxe lhd ¹⁾	1
	- Bremsleitungssätze für Rechtslenker; bitte nachfragen!	- Brake pipe sets for right hand drive; please ask for info!	
B11MGA-22	3-Fach-Verteiler 1500 bis 27988 (Stahlfelgen) 1500 bis 28539 (Speichenfelge)	3-way connection 1500 up to 27988 (steel wheels) 1500 up to 28539 (wire wheels)	1
B64aSPT	5-Fach-Verteiler	5-way connection brake pipe	1
B65SPT	3-Fach-Verteiler 1500 ab 27989 (Stahlfelgen) 1500 ab 28540 (Speichenfelgen)	3-way connection 1500 from 27989 (steel wheels) 1500 from 28540 (wire wheels)	1
B13MGA-22	Bremsschlauch 1500 vorne (Trommelbremse) + hinten (alle Modelle inkl. Twin Cam)	Brake hose front 1500 (drum brakes) + rear (all models incl. Twin Cam)	2 2
B13MGA-22AQ	Bremsschlauch Trommelbremse stahlummantelt	Brake hose (drum brakes) steel reinforced	2
B14MGA-22	Bremsschlauch vorne 1600 + MK2 (Scheibenbremse)	Front brake hose 1600 + MK2 (disc brakes)	2
B14MGA/TC	Bremsschlauch vorne Twin Cam + De Luxe	Front brake hose Twin Cam + De Luxe	2
B14MGA-22AQ	Bremsschlauch Scheibenbremse stahlummantelt	Brake hose (disk brakes) steel reinforced	2
B14MGA/TCAQ	Bremsschlauch stahlummantelt	Brake hose steel reinforced	2
B17MGA-22	Stern-Scheibe	Star-washer	1
B18MGA-22	Kontermutter	Lock nut	1
B58b	Mutter	Nut	1
B20MGA-22	Sicherungsblech 1600 + MK2	Locking plate 1600 + MK2	2
B21MGA-22	Kupferscheibe 1600 + MK2	Copper washer 1600 + MK2	2
B22MGA-22	Hohlschraube 1600 + MK2	Banjo bolt 1600 + MK2	2
E108TR3	Bremslichtschalter	Brake light switch	1
B24MGA-22	Klammer Bremsleitung	Clip brake pipe	1
B25MGA-22	Klammer Bremsleitung	Clip brake pipe	1
B26MGA-22	Klammer Bremsleitung	Clip brake pipe	1
B58c	Kupfer-Unterlegscheibe	Copper washer	A/R
B80	Messing-Bremsleitungs-Ende (Außengewinde 3/8" UNF)	Male brake pipe nut brass (outer thread 3/8" UNF)	A/R
B81	Messing-Bremsleitungs-Ende (Überwurfmutter Innengewinde 3/8" UNF)	Female brake pipe nut brass (inner thread 3/8" UNF)	A/R
B85	Bremsleitungs-Universal-Klammer, Plastik	Clip brake pipe (plastic)	A/R
B95	Kunifer-Bremsleitung * / Meterware Ø 3/16"	Kunifer brake pipe * / per metre Ø 3/16"	A/R
B200MGA	Satz Bremsschläuche stahlummantelt, mit TÜV-Gutachten: MGA / Trommelbremse,	Brake hose kit steel coated with TÜV-approval: MGA with drum brakes,	1
B200AMGA	MGA mit Scheibenbremse	MGA with disk brakes	1
B200MGA/TC	MGA Twin Cam + De Luxe	MGA Twin Cam + De Luxe	1
BR05	Bremsflüssigkeit 0,5 l	Brake Fluid 0,5 l	A/R
BRBR	Hochleistungsbremsflüssigkeit "Blue Race" von ATE, pro Liter	High performance brake fluid ATE "Blue Race", per liter	A/R
BR-Si05	Silikon Brems/Kupplungsflüssigkeit 1/2 l ²⁾	Silicone brake/clutch fluid 1/2 l ²⁾	A/R
BR-Si1	Silikon Brems/Kupplungsflüssigkeit 1 l ²⁾	Silicone brake/clutch fluid 1 l ²⁾	A/R

**2) Anmerkungen zu BR-Si05, BR-Si1:**

Silikon Brems/Kupplungsflüssigkeit zieht keine Feuchtigkeit an, wodurch Rostansatz in den Leitungen vermieden und die Flüssigkeit auch nicht mehr jährlich gewechselt werden muß.

Sie weist zudem einen höheren Siedepunkt auf, verträgt sich mit allen Gummimanschetten und greift Lacke/Farben nicht an.



ACHTUNG! Silikon Brems- und Kupplungsflüssigkeit darf nicht mit einer anderen Brems/Kupplungsflüssigkeit vermischt werden!

2) Note to BR-Si05, BR-Si1:

Silicone brake/clutch fluid does not absorb moisture from air like ordinary brake fluid. As a result, the brake/clutch pipes, the cylinders and hoses will last much longer and you do not have to change the fluid at least once a year. Also silicone brake/clutch fluid has a slightly higher boiling point.



WARNING! It is not possible to mix with other brake/clutch fluid!

³⁾ Abb. dient der Veranschaulichung, Produkt-/verpackung kann abweichen. / Image similarly, product and packing may vary.

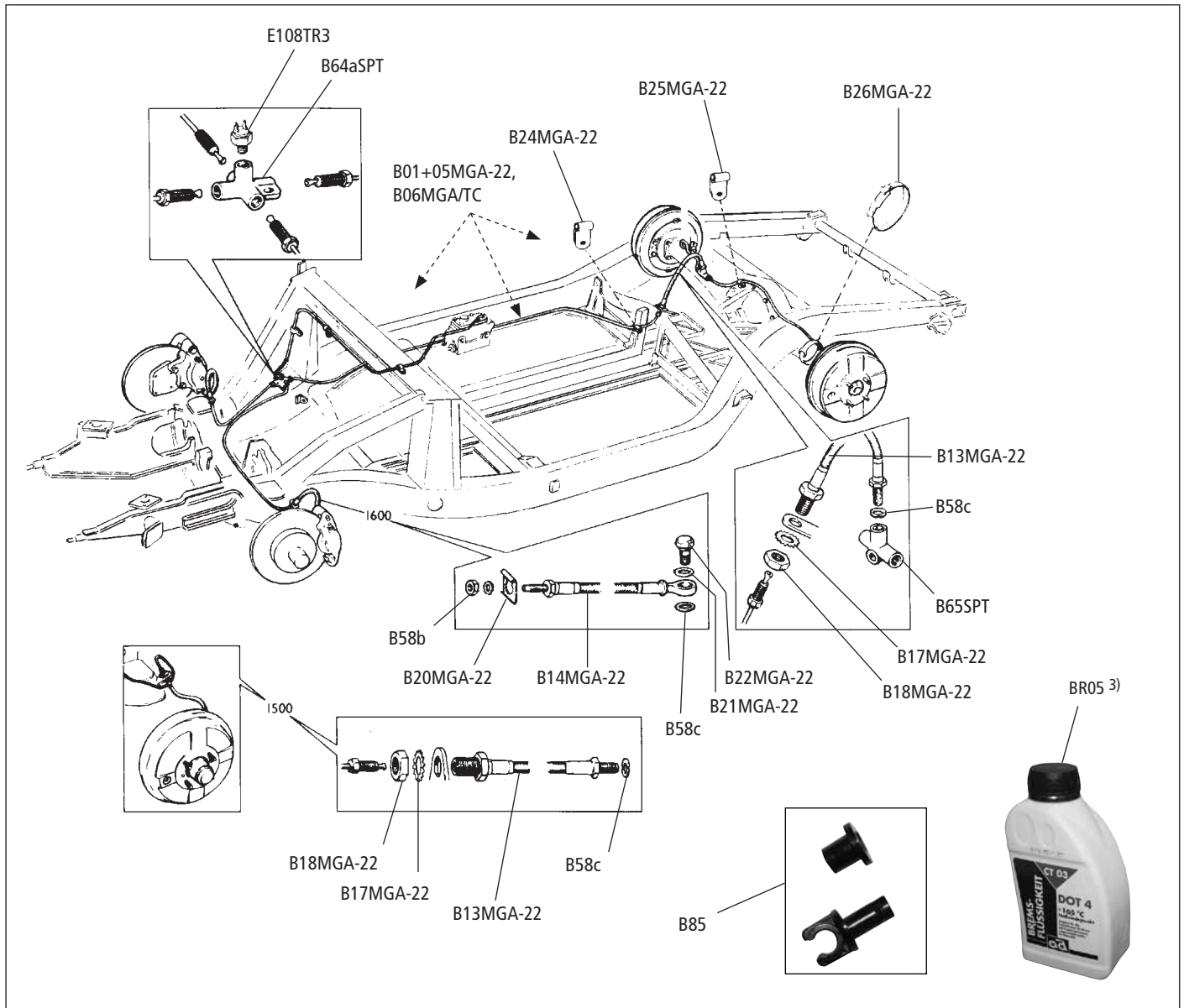

**Stahlummantelte Bremschläuche
- mit TÜV-Gutachten!**

- Super Optik
- härterer Pedaldruck
- kürzerer Pedalweg

Steel coated brake hoses - with TÜV approval!

- perfect finish
- improved pedal feeling
- less pedal travel

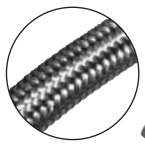

B200/B200AMGA..

Hinweis 
Note:

1) Kunifer = Korrosionsbeständige Kupfer-Messing-Legierung. Die Bremsleitungen werden mit Messingverschraubungen geliefert.

1) Kunifer-brake pipe tubing and brass tube nuts.. Made from non corroding cupro nickel with lifetime guarantee on anti corrosion.

**Brems-/Kupplungsgeberzylinder,
Bremskraftverstärker, Handbremse**
**Master cylinder brake/clutch,
brake booster, hand brake**

No.	Bezeichnung	Description	Anzahl/Qty.
B49TR2	Doppel-Zylinder Bremse/Kupplung (einschl. Einfülldeckel)	Twin brake/clutch master cylinder (incl. filler cap)	1
B49aTR2	Reparatur-Satz Doppelzylinder	Repair kit brake/clutch master	1
B03MGA-20	Dichtung Doppelzylinder oben	Top gasket brake/clutch master cylinder	1
B04MGA-20	Hohlschraube	Banjo bolt	1
B05MGA-20	Banjo-Verbindung	Banjo union	1
B06MGA-20	Anschlußstück Kupplungsleitung	Adapter clutch pipe	1
B07MGA-20	Rückschlagventil (Bremse)	Non return valve (brake)	1
B08MGA-20	Rückholfeder Hauptzylinder	Spring master cylinder	2
B10MGA-20	Stößelstange	Push rod master cylinder	2
B10MGB-20	Einfülldeckel (Plastik)	Master cylinder filler cap (plastic)	1
B12MGA-20	Gabel	Fork end	2
B14MGA-20	Pedal-Rückholfeder	Pull-off-spring pedal	2
B15MGA-20	Lagerbuchse Brems-, Kupplungspedal	Bearing bush brake/clutch master pedal	2
B16MGA-20	Abstandshülse	Spacer tube	2
B17MGA-20	Distanzscheibe	Distance washer	1
B19MGA-20	Pedalgummi (Bremse/Kupplung)	Pedal rubber (brake/clutch)	2
B20MGA-20	Handbremshebel	Handbrake lever and shaft	1
B21MGA-20	Druckstange Handbremshebel	Push rod handbrake lever	1
B22MGA-20	Arretierungsplatte Handbremshebel	Pawl handbrake lever	1
B23MGA-20	Handbremsseil „Stahlfelgen“	Handbrake cable „disc wheels“	1
B24MGA-20	Handbremsseil „Speichenräder“	Handbrake cable „wire wheels“	1
B24MGA/TC	Handbremsseil Twin Cam + De Luxe	Handbrake cable Twin Cam + De Luxe	1
B25MGA-20	Klammer Handbremsseil	Clip handbrake cable	1
B26MGA-20	Innerer Kompensationshebel	Inner handbrake compensating lever	1
B27MGA-20	Äußerer Kompensationshebel	Outer handbrake compensating lever	1
B28MGA-20	Lagerbolzen	Fulcrum	1
B30MGA-20	Feder	Spring	1
B31MGA-20	Abdeckkappe Hauptbremszylinder	Master cylinder top	1
B33MGA-20	Dichtung Original-Einfülldeckel	Washer for original filter cap	1
B38MGA-20	Gummimanschette Pedalerie	Rubber pedal seal	1
B38MGA/TC	Gummimanschette Pedalerie Twin Cam	Rubber pedal seal Twin Cam	1
B39MGA-20	Einstellmutter Handbremsseil	Handbrake cable adjusting nut	1
B42MGA-20	Gummi Abdeckplatte Beifahrerseite	Rubber blanking plate passengers side	1
B43MGA-20	Distanzbuchse	Distance bush	1
B44MGA-20	Buchse	Bush	2
B45MGA-20	Gelenkblock	Trunnion	1
B46MGA-20	Halteplatte Gummidichtung	Retaining plate rubber boot	2
B47MGA-20	Klammer	Clip	1
B49BTR2	Dichtung Hauptzylinder seitlich	Side gasket master cylinder	1
B50MGA/TC	Hauptbremszylinder Nachfertigung (Twin Cam)	Master brake cylinder - repro (Twin Cam)	1
B50aMGA/TC	Rep.-Satz für Original Dunlop Hauptbremszyl. (nur Gummis)	Repair kit for origine Dunlop master cylinder (only rubbers)	1
B69SPT	Verbindungsstift	Clevis pin	2
ZK85SPT	Kontermutter Stößelstange	Nut adj. Push rod master cylinder	1
B110	Bremskraftverstärker zum Nachrüsten alle 1-Kreis Bremsanlagen, einfach zu montieren	Brake booster - all single circuit brake systems Easy fitting.	1
BR05	Bremsflüssigkeit 0,5 l	Brake Fluid 0,5 l	A/R
BRBR	Hochleistungsbremsflüssigkeit "Blue Race" von ATE, pro Liter	High performance brake fluid ATE "Blue Race", per liter	A/R
BR-Si05	Silikon Brems/Kupplungsflüssigkeit 1/2 l *	Silicone brake/clutch fluid 1/2 l *	A/R
BR-Si1	Silikon Brems/Kupplungsflüssigkeit 1 l *	Silicone brake/clutch fluid 1 l *	A/R

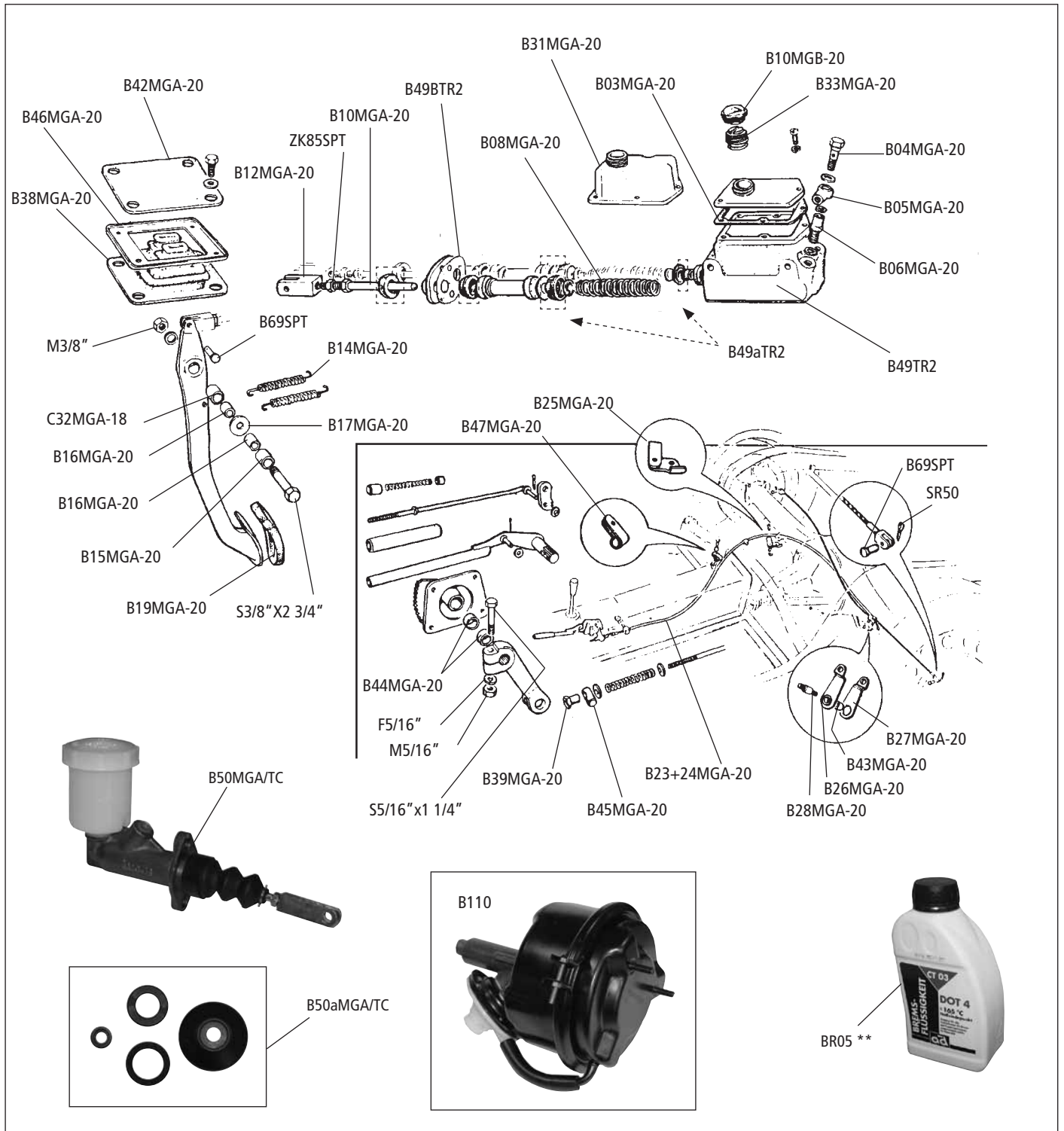

*** Anmerkungen zu BR-Si05, BR-Si1:**

Silikon Brems/Kupplungsflüssigkeit zieht keine Feuchtigkeit an, wodurch Rostansatz in den Leitungen vermieden und die Flüssigkeit auch nicht mehr jährlich gewechselt werden muß.

Sie weist zudem einen höheren Siedepunkt auf, verträgt sich mit allen Gummimanschetten und greift Lacke/Farben nicht an.

! ACHTUNG! Silikon Brems- und Kupplungsflüssigkeit darf nicht mit einer anderen Brems/Kupplungsflüssigkeit vermischt werden!

*** Note to BR-Si05, BR-Si1:**

Silicone brake/clutch fluid does not absorb moisture from air like ordinary brake fluid. As a result, the brake/clutch pipes, the cylinders and hoses will last much longer and you do not have to change the fluid at least once a year. Also silicone brake/clutch fluid has a slightly higher boiling point.

! WARNING! It is not possible to mix with other brake/clutch fluid!

** Abb. dient der Veranschaulichung, Produkt-/verpackung kann abweichen. / Image similarly, product and packing may vary.

Gummistopfen / Rubber plugs

No.	Bohrungs-Ø in Karosserie / Diam. in body
RS6	6 mm
RS8	8 mm
RS12	12 mm
RS14	14 mm

No.	Bohrungs-Ø in Karosserie / Diam. in body
RS18	18 mm
RS20	20 mm
RS22	22 mm
RS25	25 mm

No.	Bohrungs-Ø in Karosserie / Diam. in body
RS28	28 mm
RS30	30 mm

Kabeltüllen / Cable spouts

No.	Bohrungs-Ø in Karosserie / Diam. in body
RT6	6 mm
RT9	9 mm
RT10	10 mm
RT11	11 mm
RT14	14 mm
RT17	17 mm

No.	Bohrungs-Ø in Karosserie / Diam. in body
RT20	20 mm
RT21	21 mm
RT24	24 mm
RT30	30 mm
RT34	34 mm
RT38	38 mm

No.	Bohrungs-Ø in Karosserie / Diam. in body
RT1 "	25,4 mm (1")

Tülle für Tachowelle, Drehzahlmesserwelle /
Cable spout for speedo cable, rev. counter cable

Zündung, Verteiler / Ignition, Distributor

No.	Bezeichnung	Description	Anzahl/Qty.
E01MGA-29	AT-Zündverteiler 1500/1600	Exchange distributor MGA1500/1600	1
E01MGA/TC	AT-Zündverteiler Twin Cam (nur Überholung des eigenen Verteilers möglich!)	Exchange distributor Twin Cam (rebuilding of your existing distributor!)	1
E01MGA/1500/N	Zündverteiler, neu 1500/1600	Distributor, new 1500/1600	1
E02MGA-29	AT-Zündverteiler (Lucas 40780) 1622	Exchange distributor MGA1622 (Lucas 40780)	1
E02MGA1622/N	Zündverteiler, neu 1622	Distributor, new 1622	1
E1TR6	Unterbrecherkontakt	Contact set	1
E1TR4	Unterbrecherkontakt Twin Cam	Contact set Twin Cam	1
E2TR4	Verteilerfinger - alle Modelle inkl. Twin Cam	Rotor arm - all models incl. Twin Cam	1
E3TR6	Kondensator - alle Modelle inkl. Twin Cam	Condenser - all models incl. Twin Cam	1
E5SPT	Befestigungsschraube Unterbrecherkontakt	Contact retaining screw	1
E6TR4	Satz Zündkabel geschraubt (nicht Twin Cam)	Plug lead set, screwed (not Twin Cam)	1
E6SPT	Satz Zündkabel gesteckt	Plug lead set, plugged	1
E8aTR	Federsatz (Vorstellung + Verzögerung) (2 tlg)	Advance/retard spring set (2 pcs)	1
E9TR6	Stecker + Kabel	Terminal bush + lead	1
E10MGA-29	Unterdruckdose	Vacuum box distributor	1
E11MGA-29	Verteilerkappe	Distributor cap	1
E12MGA-29	Halteklammer Zündverteiler	Distributor clamp	2
E12SPTMK3	Zündspule (SteckanschlüÙe)	Ignition coil (spade connector)	1
E13SPTMK4	Zündkerze (nicht Twin Cam)	Spark plug (not Twin Cam)	4
E13MGA/TC	Zündkerze (Twin Cam)	Spark plug (Twin Cam)	4
E14MGA-30	Zündkabel-Durchführung	Ignition lead spacer	1
E16MGA-29	Schrauben-, Kleinteilesatz Zündverteiler	Sundries parts kit distributor	1
E16/T	Batterie-Trennschalter für Minus-Polanschluß	Battery isolator negative pole connector	1
E17	Unterdruckleitung Kunststoff mit 2x Anschlußgummis, ca. 1,5 m	Suction pipe plastic with 2x connector, ca. 1,5 m	1
E28MGA-29	Unterdruckleitung	Suction pipe metal	1
E24MGA-33	Erdungskabel Motor/Chassis	Battery lead negative	1
E25MGA-33	Verbindungskabel Batterien	Cable between battery's	1
E26MGA-33	Kabel Anlasserschalter/Anlasser	Cable starter solenoid/starter motor	1
E27MGA-33	Kabel Batterie/Anlasserschalter	Cable battery/starter switch	1
S30MGA	Batteriehalteset in Edelstahl, poliert	Polished stainless steel battery packing set	1
E30MGA-29	Befestigungsclip	Retaining clip	1
E31MGA-29	Gummiverbinder Unterdruckleitung	Vacuum connection rubber	1
E33MGA-29	Schraube Vergaserende	Screw carburettor end	1
E41MGA-30	Zündkerzenstecker Lucas	Cap, spark plug, Lucas style	4
E70MGB-23	Kabel Batterie/Chassis	Battery lead positive	1
E70AH	Batterie trocken 6V	Battery 6-volts, dry-charged	2
E70AH/HD	Batterie trocken 6V Hochleistungsbatterie	Battery 6-volts, high performance, dry-charged	2
M285MGA-TC	Dichtolive	Olive vacuum pipe	1

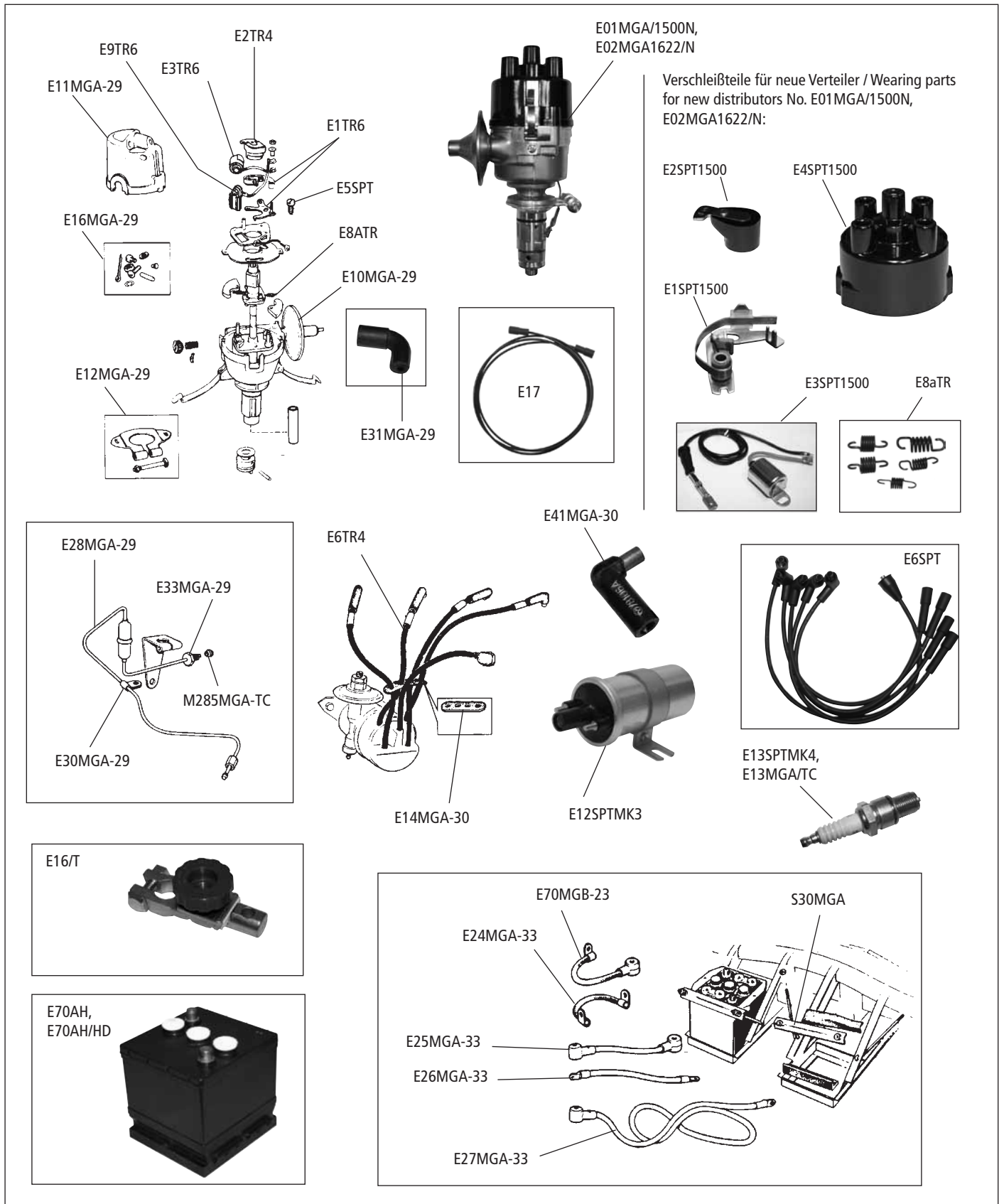

Verschleißteile für neue Verteiler / Wearing parts for new distributors No. E01MGA/1500N, E02MGA/1622/N:

No.	Bezeichnung	Description	Anzahl/Qty.
E4SPT1500	Verteilerkappe	Cap, distributor	1
E2SPT1500	Verteilerfinger	Rotor	1
E1SPT1500	Unterbrecherkontakt	Point set	1
E3SPT1500	Kondensator	Condensor	1
E8aTR	Satz Verteilerfedern	Spring set	1

No.	Bezeichnung	Description	Anzahl/Qty.
E08MGA-34	Kabelbaum 1500 umwebt	Wiring loom 1500 braided	1
E09MGA-34	Kabelbaum 1500 Kunststoff	Wiring loom 1500 PVC	1
E10MGA-34	Kabelbaum 1600/MK2/De Luxe umwebt *	Wiring loom 1600/MK2/de Luxe braided *	1
E11MGA-34	Kabelbaum 1600/MK2/De Luxe Kunststoff *	Wiring loom 1600/MK2/de Luxe PVC *	1
E17MGA-35	Kartenleselampe	Map reading lamp	1
E18MGA-34	Klammer Kabelbaum	Clip wiring loom	A/R
E18AMGA-35	Gummidichtring	Seal	1
E18MGA-35	Chromkappe	Cover	1
E19MGA-35	Lampenglas	Lens	1
E19MGA-34	Klammer Kabelbaum + Batteriekabel	Clip wiring loom + battery leads	A/R
E20MGA-34	Hupe Tiefton „original“	Horn low tone „original“	1
E21MGA-34	Hupe Hochton „original“	Horn high tone „original“	1
E21MGA-35	Hupenknopf	Horn push	1
E31MGA-34	Blinkrelais (Schraubanschlüsse)	Flasher unit (screw connection)	1
E37MGA-34	Blinker-Kontroll-Relais 1500 + Twin Cam (früher Typ)	Flasher relay 1500 + Twin Cam (early type)	1
E38MGA-34	Abblendlichtschalter (Schraubanschlüsse)	Foot dipping switch (screw connection)	1
E41MGA-34	Starterzug Linkslenker	Starter cable lhd	1
E42MGA-34	Klemme Starterzug	Clip starter cable	1
E43MGA-34	Starterschalter	Starter switch	1
E44MGA-34	Gummi Abdeckkappe	Boot battery lead	1
E45MGA-34	Satz „Lucas“ Kabelbaum Aufkleber	Set „Lucas“ wiring harness labels	1
E108TR3	Bremslicht-Schalter	Brake light switch	1
E106SPT	Blinkrelais (Steckanschlüsse)	Flasher unit (spade connection)	1
E116SPT	Warnblinkanlage zum Nachrüsten	Warning flasher unit 12 V	1
E129SPT	Abblendlichtschalter (Steckanschlüsse)	Foot dipping switch (spade connection)	1
E305SPT	Magnetschalter	Solenoid, starter	1
E327TR3	Regler (Schraubanschlüsse)	Voltage control box (screw connection)	1
E401	1-Fach Kabelverbinder	Cable connector 1-way	A/R
E402	2-Fach Kabelverbinder	Cable connector 2-way	A/R
E403	Kabelstecker	Wiring connector bullet	A/R
E409	3-Fach Kabelverbinder	Cable connector 3-way	A/R
E410TR3	Sicherungskasten (Schraubanschlüsse)(ohne Deckel)	Fuse box (screw-on connection)(without cover)	1
E410SPT	Sicherungskasten (Steckanschlüsse) (mit Deckel)	Fuse box (spade connection)(with cover)	1
E415SPT35	Glassicherung 35 Ampere	Fuse 35 amp.	A/R
E415SPT/50	Glassicherung 50 Ampere	Fuse 50 amp.	A/R
E435SPT	Satz Hupen Hoch- und Tiefton (Zubehör)	Horn kit, low and high note	1
E460SPT	Glühbirne	Bulb	A/R

* auch für Twin Cam

* also for Twin Cam models



E08-11MGA-34

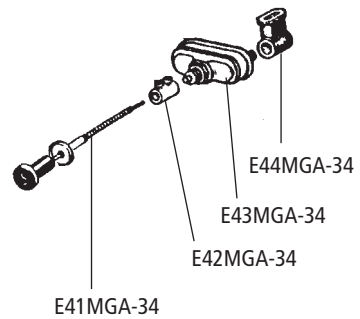
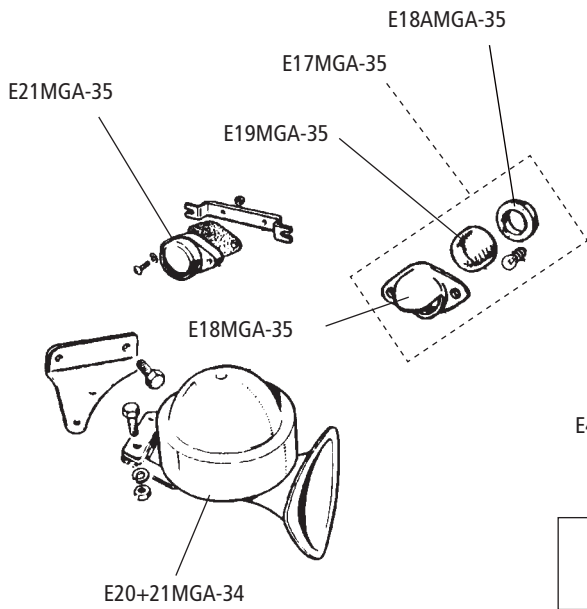

E460SPT



E415SPT35
E415SPT50



E31MGA-34
E106SPT



E37MGA-34



E38MGA-34
E129SPT



E108TR3



E327TR3



E410TR3
E410SPT



E435SPT



E116SPT

No.	Bezeichnung	Description	Anzahl/Qty.
E01MGA-35	Kontrolllampe Blinker	Lamp, turn indicator	1
E04MGA-35	Blinkerschalter	Flasher switch	1
E109TR6	Dimmerschalter Instrumentenbeleuchtung	Rheostat switch panel light	1
E126SPT	Schalter Nebelscheinwerfer und Schalter Kartenleselampe	Switch single system & Switch map reading lamp	1
E141TR3	Stand-, Hauptlichtschalter	Head/side lamp switch	1
E12MGA-35	Elektroteil Zündschloß	Ignition switch	1
E17MGA-35	Kartenleselampe	Map reading lamp	1
E18MGA-35	Chromkappe Kartenleselampe	Cover map reading lamp	1
E18AMGA-35	Gummidichtring	Seal	1
E19MGA-35	Lampenglas	Glass map reading lamp	1
E20MGA-35	Satz Bedienungsknöpfe Armaturenbrett, Heizung (5-tlg)	Knob set switches dashboard/heater (5 pcs)	1
E21MGA-35	Hupenknopf	Horn push	1
i23AMGA-39	Lederscheibe	Leather joint washer	1
E24MGA-35	Instrumenten-Dichtring „groß“	Sealing ring instrument glass „large“	2
E25MGA-35	Instrumenten-Dichtring „klein“	Sealing ring instrument glass „small“	2
E26MGA-35	Instrumenten-Glass „groß“	Glass instrument „large“	2
E27MGA-35	Instrumenten-Glass „klein“	Glass instrument „small“	2
E28MGA-35	Rändelmutter Instrumentenbefestigung für Tachometer und Drehzahlmesser	Thumb screw instrument for speedometer and tachometer	4
E28aMGA-35	Rändelmutter Instrumentenbefestigung (klein) für Tankuhr, Temperaturanzeige..	Thumb nut instrument (small), for fuel gauge, temperature gauge..	4
RT29MGA	Satz Kabeltüllen Spritzwand (33 Teile)	Grommet set, bulkhead (33 pieces)	1
E32MGA-35	Leitung Öldruckanzeige	Oil gauge pipe	1
E33MGA-35	Öldruckschlauch	Flexible hose oil gauge pipe	1
E34MGA-35	Lautsprecher-Umrandung	Speaker bezel	1
E35MGA-35	Lautsprecher-Netz	Speaker mesh	1
E36MGA-35	Abdeckplatte Lautsprecherloch	Cover plate speaker mesh	1
E40MGA-35	Kederband schwarz (per 30 cm)	Dash piping black (per foot)	A/R
E41MGA-35	Kederband rot (per 30 cm)	Dash piping red (per foot)	A/R
E42MGA-35	Kederband braun (per 30 cm)	Dash piping brown (per foot)	A/R
E43MGA-35	Kederband weiß (per 30 cm)	Dash piping white (per foot)	A/R
E45MGA-35	Drehzahlmesserwelle Linkslenker	Rev. counter cable lhd	1
E46MGA-35	Drehzahlmesserwelle Rechtslenker	Rev. counter cable rhd	1
E41MGA-34	Starterzug Linkslenker	Starter cable lhd	1
E48MGA-35	Starterzug Rechtslenker	Starter cable rhd	1
E49MGA-35	Chokezug Linkslenker	Choke cable lhd	1
E50MGA-35	Chokezug Rechtslenker	Choke cable rhd	1
E54MGA-35	Blendensatz Radioöffnung	Radio blanking plate set	1
E55MGA-35	Prallpolstersatz Rechtslenker	Under dash pad set rhd	1
E56MGA-35	Prallpolstersatz Linkslenker	Under dash pad set lhd	1
E57MGA-35	Bekleidung Armaturenbrett unten Linkslenker	Trim dash bottom lhd	1
E59MGA-35	Schraube Hebel Blinkerschalter	Screw flasher switch handle	1
E60MGA	Hebel Blinkerschalter	Flasher switch handle	1
i107TR	Befestigungsclip Kederband Armaturenbrett	Clip dash piping	8
E121SPTMK3	Zündschloßbeinsatz + Schlüssel	Ignition barrel and key	1
E460SPT	Schraubbirne	Bulb (screwed)	A/R
E495SPTMK3	Blinkerkontrollleuchte grün, ohne Fassung	Lamp, turn indicator green, without holder	1
G37MGA-19	Tachowelle (62")(158 cm) Rechtslenker	Speedo cable (62")(158 cm)	1
G39MGA-19	Tachowelle (66")(168 cm) Rechtslenker	Speedo cable (66")(168 cm)	1
W1SPTMK3	Tachowelle (69")(176 cm) Linkslenker	Speedo cable (69")(176 cm)	1

Tachowellen; siehe Seite 38

Speedo cables; see page 38

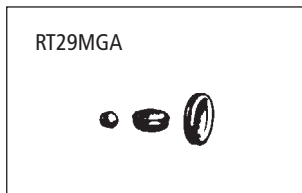
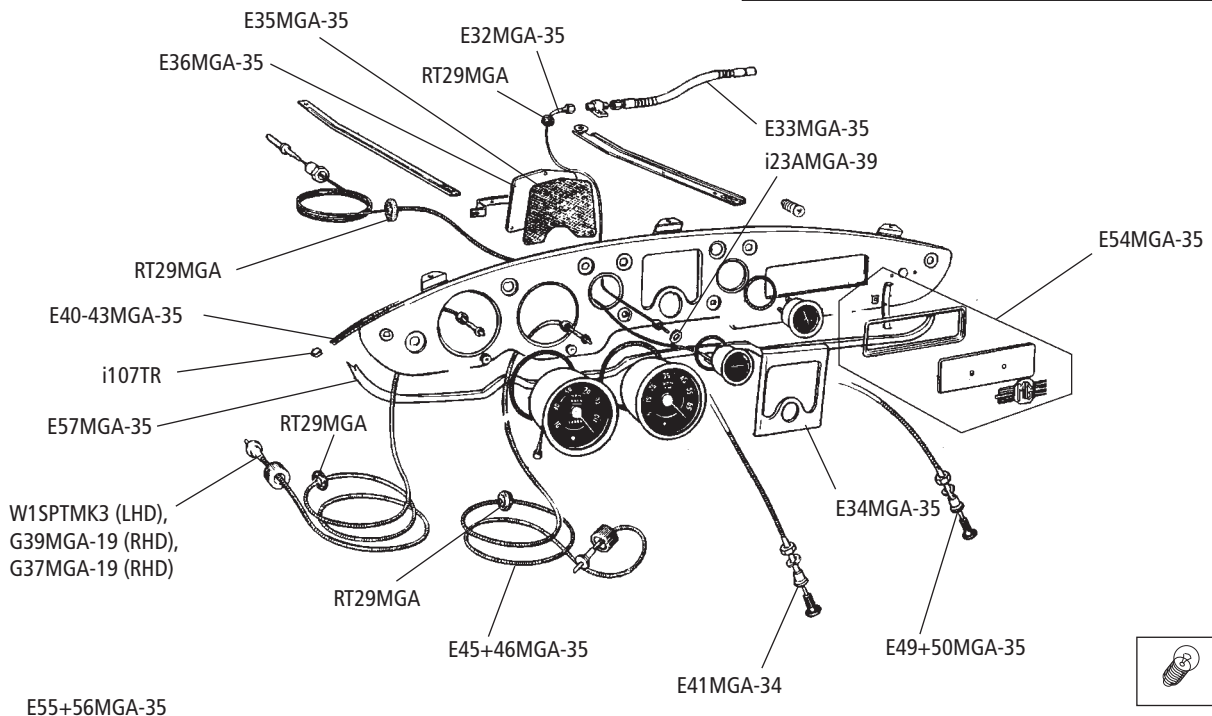
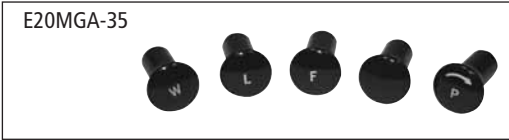
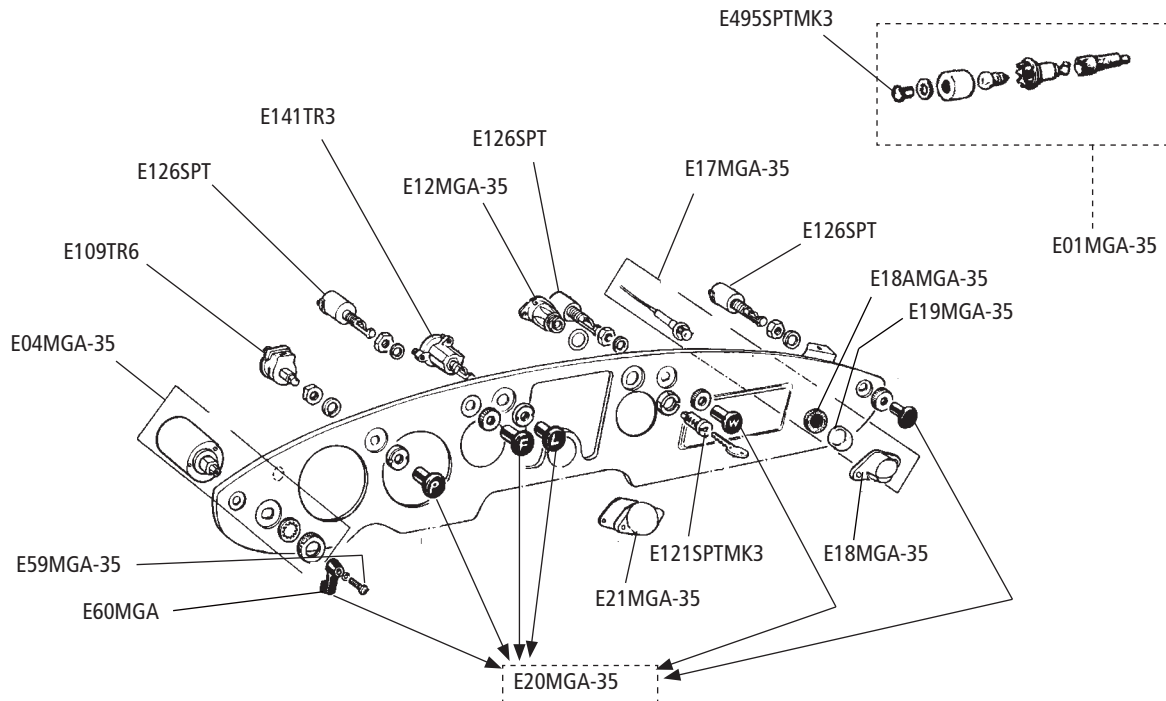

No.	Bezeichnung	Description	Anzahl/Qty.
E33MGA-35	Öldruckschlauch ab Motorblock	Oil pipe from block on	1
E08MGB-26	Verbindungsstück Öldruckschlauch (mechanische Anzeige)	Connector oil pipe to gauge (mechan. system)	1
E460SPT	Schraubbirne Armaturenblechbeleuchtung	Bulb instrument panel	A/R
E471SPT	Schlauch Öldruckinstrument	Hose to oil pressure gauge	1
E475ESPT	Öltemperaturinstrument elektrisch, mit Chromrand	Oil temperature gauge, electrical with chrome ring	1
E475MSPT	Öltemperaturinstrument mechanisch, mit Chromrand	Oil temperature gauge, mechanical with chrome ring	1
E475aSPT	Geber für Öltemperaturinstrument E475SPT oder Wassertemperaturinstrument E485SPT	Transmitter oil temperature gauge E475SPT or water temperature E485SPT	1 1
E475bSPT	Adapter zu E475SPT an Ölwanne oder zu E485SPT an Thermostatgehäuse	Adaptor to E475SPT to oil sump or to E485SPT to thermostat housing	1 1
E476SPT	Amperemeter mit Chromrand	Amperemeter gauge with chrome ring	1
E477SPT	Voltmeter mit Chromrand	Voltmeter gauge with chrome ring	1
E478SPT	Zeituhr mit Chromrand	Clock with chrome ring	1
E480SPT	Doppelinstrument Wassertemperatur u. Öldruck	Double instrument water temperature and oil pressure gauge	1
E480bSPT	Adapter für E480SPT (Wasseranschluß)	Adaptor for E480SPT (Water connection)	1
E481SPT	Öldruckinstrument mechanisch	Oil pressure gauge	1
E482SPT	Tankuhr	Fuel gauge	1
E485SPT	Wassertemperaturinstrument mechanisch	Water temperature gauge, mechanical	1
E490SPT/52	Chromrand für "SMITHS" Instrumente Ø 52 mm	Chrome ring for "SMITHS" instruments Ø 52 mm	A/R
E490SPT/80	Chromrand für "SMITHS" Instrumente Ø 80 mm	Chrome ring for "SMITHS" instruments Ø 80 mm	A/R
E490SPT/100	Chromrand für "SMITHS" Instrumente Ø 100 mm	Chrome ring for "SMITHS" instruments Ø 100 mm	A/R



Hinweis 

Original-Tachometer und Drehzahlinstrumente sind nicht mehr lieferbar. Diese Instrumente können aufbereitet werden. Lieferzeit ca. 6-8 Wochen. Bitte fragen Sie nach!

Original Speedo/Tachometer instruments are not longer available. Please ask for our service to rebuild the instruments!

No.	Bezeichnung	Description	Anzahl/Qty.
E300SPT	Anlasser überholt, kein Austausch erforderlich	Starter motor, rebuild - no exchange required	1
E301SPT	Satz Anlasser-Kohlen	Set starter motor brushes	1
E320SPT	Gleichstrom-Lichtmaschine Typ C40	Dynamo Type C40	1
E31MGA-33	Satz Lichtmaschinenkohlen (Typ C39/22258)	Set dynamo brushes (type C39/22258)	1
E322SPT	Satz Lichtmaschinenkohlen (Typ C40/22700/22704/22715)	Set dynamo brushes (type C40/22700/22704/22715)	1
E33MGA-33	Lüfterrad (Typ C40/22700/22704/22715)	Fan dynamo (type C40/22700/22704/22715)	1
E321SPTA/70	Keilriemenscheibe bis 16Gah6395	Dynamo pulley up to 16Gah6395	1
E35MGA-33	Keilriemenscheibe ab 16Gah6396	Dynamo pulley from 16Gah6395	1
HM7/16"	Mutter	Nut jam	1
E38MGA-33	Federkeil	Woodruff key	1
E300AMGBRACE	Hochleistungs-Getriebeanlasser - ersetzt E300SPT	High performance starter motor - replaces E300SPT	1
E310COMP	Hochleistungs-Lichtmaschine Drehstrom (40 Amp.) inkl. Riemenscheibe (schmal)	High performance AC Alternator (40 Amp/12V) incl. pulley	1
E310BRKT-MGA	Haltesatz für E310COMP inkl. Keilriemen (MGA/MGB)	Fitting kit for E310COMP incl. V-belt (for MGA/MGB)	1
K18MGA-914	Keilriemen separat für Umbausatz E310BRKT-MGA	V-belt, separately to fitting kit E310BRKT-MGA	1

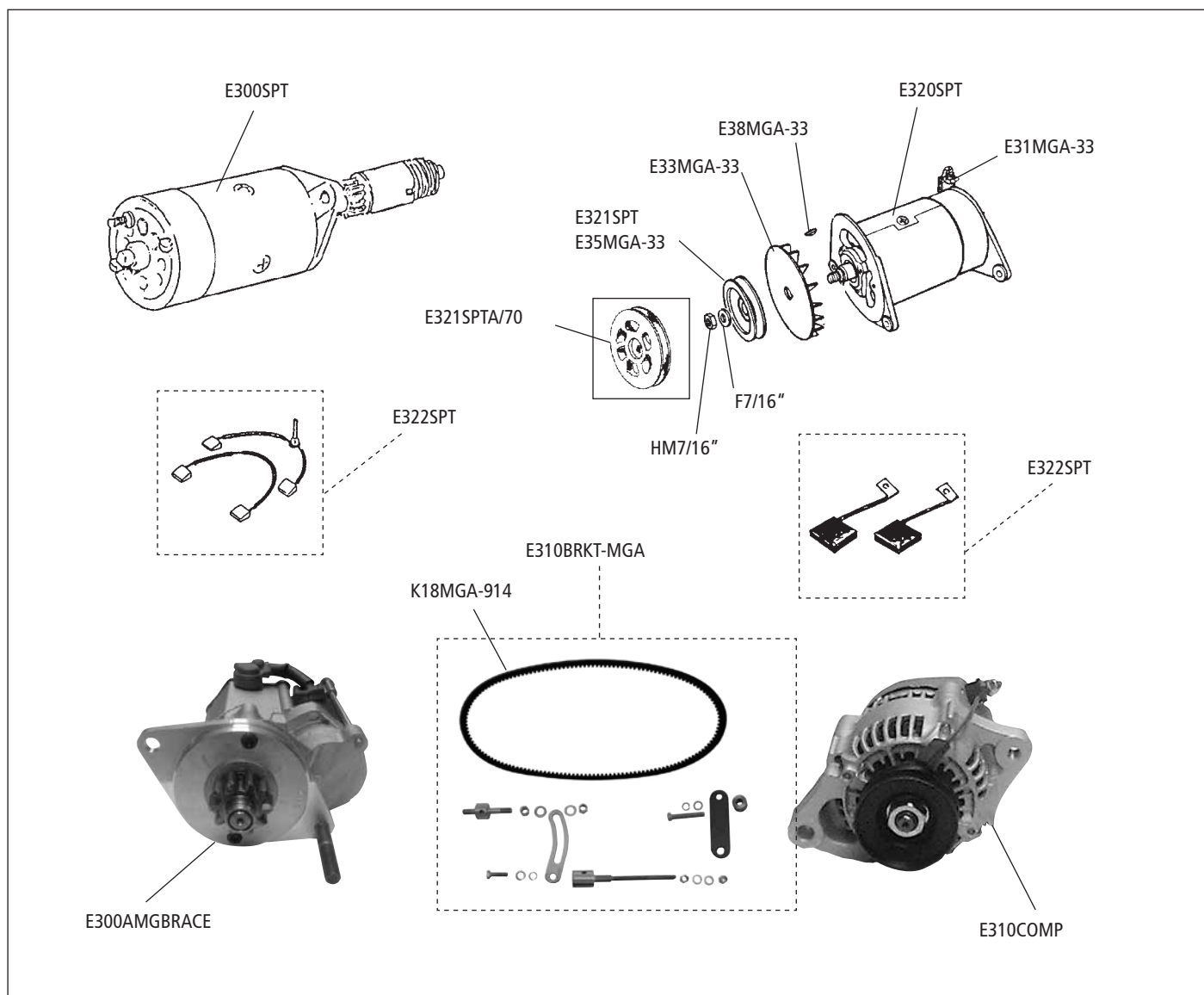

No.	Bezeichnung	Description	Anzahl/Qty.
E200TR	Paar Scheinwerfereinsätze H4 mit integr. Standlicht, lhd inkl. Birne	Pair H4 headlamp units, with pilot lamp, lhd incl. bulb	1
E200SPT	Paar Scheinwerfereinsätze H4 ohne Standlicht, lhd inkl. Birne	Pair H4 headlamp units, without pilot lamp, lhd incl. bulb	1
E201TR6	Lampenstecker mit Kabel	Adapter bulb „Europe“ with lead	2
E202SPT	Lampentopf Kunststoff (2 Einsteller)	Headlamp body polyester (2 adj. Type)	2
E203SPT	Set Scheinwerfer-Einstellschrauben, Federn + Schrauben (2 Einsteller)	Headlamp screw trimmer set (2 adj. Type)	2
E33MGA-30	Dichtung Scheinwerfertopf/Karosserie (2 Einsteller)	Headlamp rubber (2 adj. Type)	2
E34MGA-30	Haltering-Set Scheinwerfer (2 tlg)	Headlamp mounting rim set (2 pcs)	2
E37MGA-30	Staubschutzgummi	Headlamp dust excluder	2
E38MGA-30	Chrom-Scheinwerferring außen	Headlamp rim	2
E39MGA-30	Halteclip Scheinwerferring/-Topf	Headlamp rim clip	2
E42MGA-30	Schraube Lampenring	Headlamp rim screw	2
E200a	Paar Steinschlagschutzgitter	Pair headlamp stoneguard	1
E202aSPT	Lampentopf komplett, Metall (ohne Dichtung Scheinwerfertopf/ Karosserie) 2 Einsteller	Headlamp body kit, steel (w/o headlamp rubber) 2 adj. Type	2
E01MGA-31	Blinker vorne (mit weißem Glas) 1500 + Twin Cam	Front flasher lamp (clear lens) 1500 + Twin Cam2	2
E02MGA-31	Blinkerglas (klar) mit Chromring	Front flasher lens with chrome ring	2
E03MGA-31	Satz Dichtungen (2 tlg)	Seal set lens mounting (2 pcs)	2
E05MGA-31	Gummiunterlage Blinker	Rubber washer front flasher lamp	2
E06MGA-31	Gummikappe	Rubber boot	2
E07MGA-31	Blinker vorne (gelb/weißem Glas) 1600 + MK2	Front side/flasher lamp (amber/white lens) 1600 + MK2	2
E08MGA-31	Blinkerglas (gelb/weiß)	Side/flasher lens (amber/white)	2
E09MGA-31	Satz Dichtungen (2 tlg)	Seal set flasher (2 pcs)	2
E12MGA-31	Gummiunterlage Blinker	Rubber pad flasher	2
E16MGA-31	Gummidichtung Rückleuchtenglas	Dust excluder stop/tail lamp	2
E17MGA-31	Gummiunterlage Sockel Rückleuchte/Karosserie	Rubber gasket plinth/body	2
E18MGA-31	Grundplatte Rückleuchte	Chrome base plate stop/tail lamp	2
E20MGA-31	Sockel Rückleuchte 1500 rechts	Rear lamp plinth 1500 right hand	1
E21MGA-31	Sockel Rückleuchte 1500 links	Rear lamp plinth 1500 left hand	1
E24MGA-31	Blinker hinten komplett (Kunststoff- "Glas")	Rear flasher lamp (amber plastic lens)	2
E26AMGA-31	Blinkerglas (Glas) rot	Flasher lens red glass	2
E27MGA-31	Blinkerglas (Kunststoff) gelb	Flasher lens amber plastic	2
E29MGA-31	Sockel Rückleuchte/Blinker 1600 rechts	Plinth stop/tail lamp 1600 right hand	1
E30MGA-31	Sockel Rückleuchte/Blinker 1600 links	Plinth stop/tail lamp 1600 left hand	1
E31MGA-31	Dichtung Sockel 1600	Rubber gasket plinth 1600	2
E32MGA-31	Schraube Lampenglas	Screw lamp lens	A/R
E33MGA-31	Rückleuchte 1600 MK2 + De Luxe rechts	Stop/tail lamp 1600 MK2 + de Luxe right hand	1
E34MGA-31	Rückleuchte 1600 MK2 + De Luxe links	Stop/tail lamp 1600 MK2 + de Luke left hand	1
E35MGA-31	Rücklichtglas 1600 MK2 rechts (rot)	Stop/tail lens 1600 MK2 right hand (red)	1
E36MGA-31	Rücklichtglas 1600 MK2 links (rot)	Stop/tail lens 1600 MK2 left hand (red)	1
E37MGA-31	Blinkerglas 1600 MK2 rechts (gelb)	Flasher lens 1600 MK2 right hand (amber)	1
E38MGA-31	Blinkerglas 1600 MK2 links (gelb)	Flasher lens 1600 MK2 left hand (amber)	1
E39MGA-31	Dichtung Rücklichtglas/Fassung	Gasket lens/base	2
E40MGA-31	Dichtung Fassung/Sockel	Gasket base/plinth	2
E41MGA-31	Unterlage Sockel/Karosserie	Base plinth	2
E50MGA-31	Schraube Lampenglas	Screw lens to base	2
E211TR3	Rückleuchte komplett 1500 + 1600	Stop/tail lamp assembly 1500 + 1600	2
E212TR3	Rückleuchtenglas	Stop/tail lamp lens	2
E212SPT	Gummiunterlage Rückleuchte/Sockel	Rubber wash er rear lamp base	2
E230SPT	Blinker hinten komplett (Glas)	Rear flasher lamp (amber glass lens)	2
E231SPT	Blinkerglas (Glas) gelb	Flasher lens amber glass	2
E232SPT	Chromring	Chrome side/flasher rim	2
E233ASPT	Fassung	Bulbholder	2
E234SPT	Gummigehäuse Blinker	Rubber body flasher lamp	2
E260SPT	Nummernschildleuchte	Number plate lamp	1
E261SPT	Dichtung unter Nummernschildleuchte	Seal, rubber	1

Zeitgenössisches Zubehör: Fern- und Nebelscheinwerfer**Period Style: Driving and Fog Lamps**

E205	Zusatz Fernscheinwerfer (Befestigung unten)	High beam headlamp (stemmount)	2
E205a	Zusatz Fernscheinwerfer (Befestigung hinten)	High beam headlamp (backmount)	2
E206	Zusatz Nebelscheinwerfer n(Befestigung unten)	Fog lamp (stemmount)	2
E206a	Zusatz Nebelscheinwerfer (Befestigung hinten)	Fog lamp (backmount)	2
E720	Glühbirne für Fernscheinwerfer	Bulb for high beam headlamp	2
E721	Glühbirne für Nebelscheinwerfer (12V-48W)	Bulb for fog lamp (12V-48W)	2

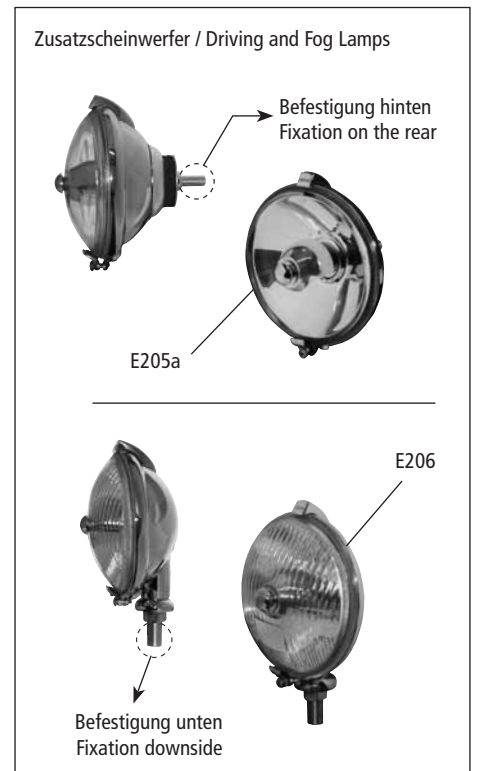
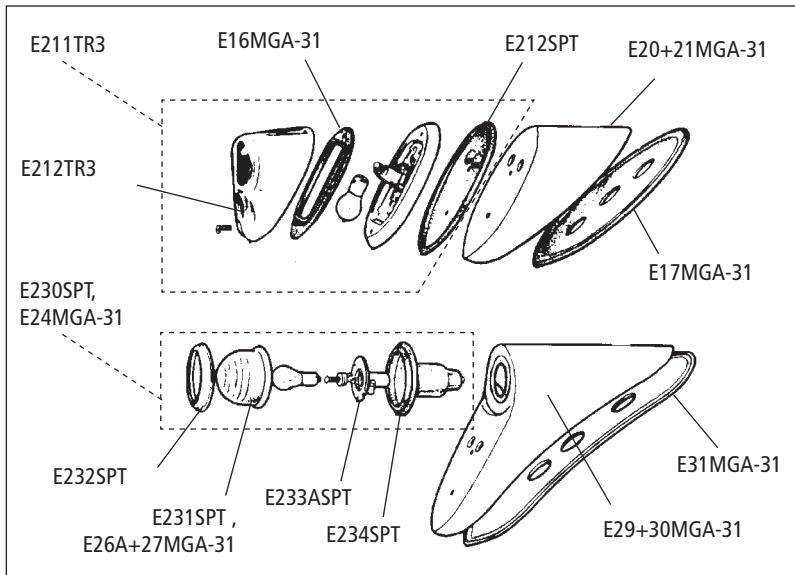
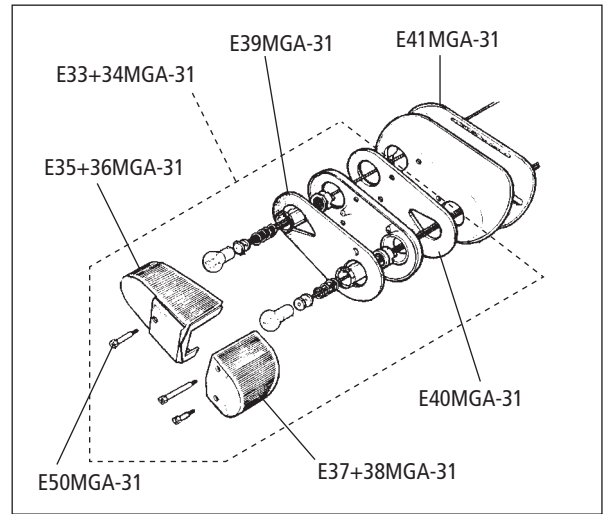
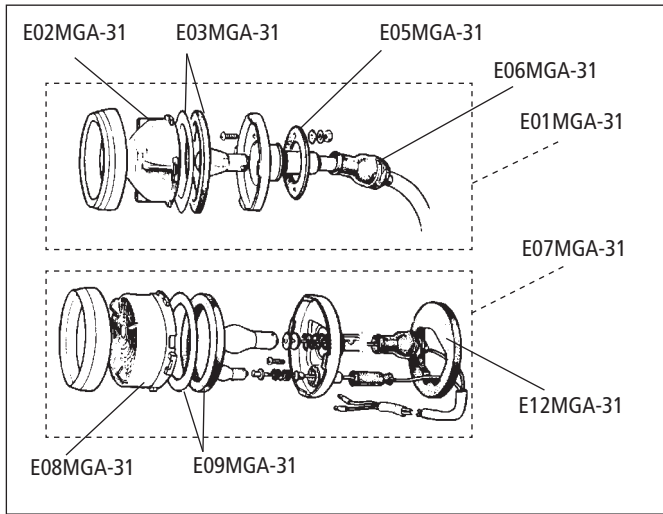
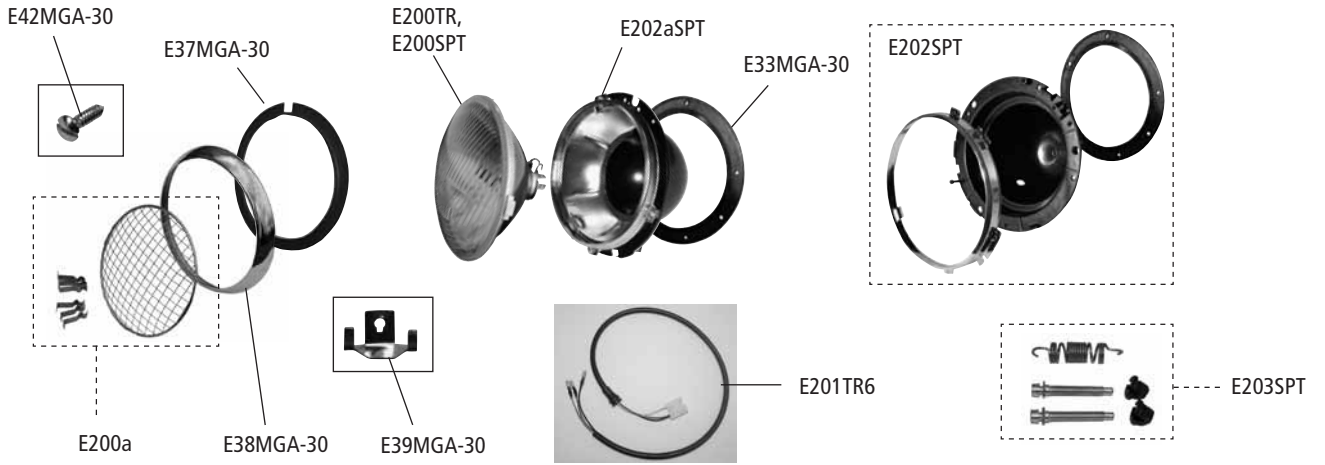

No.	Bezeichnung	Description	Anzahl/Qty.
E542TR3	Austausch-Wischermotor, Typ „DR2“	Exchange „DR2“ wiper motor 1-speed	1
E540SPT	Austausch-Wischermotor, Typ „DR3A“	Exchange „DR3A“ wiper motor 1-speed	1
E04MGA-33	Satz Kohlen Wischermotor (2 tlg)	Brush set wiper motor (2 pcs)	1
E05MGA-33	Befestigung-Kit Wischermotor	Wiper motor mounting kit	3
RT29MGA	Satz Gummidurchführung Spritzwand	Grommet set bulkhead	1
E07MGA-33	Wischer-Antriebskabel	Wiper rack	1
E510TR5	Wischergetriebe	Wiper gear	2
E09MGA-33	Anbauteil Wischerarmantrieb	Wiper wheelbox bezel	2
E512SPT	Dichtung Wischerarmtrieb/Karosserie	Wiper wheelbox gasket	2
E513SPT	Chrommutter Wischerarmtrieb	Wiper wheelbox chrome nut	2
E505TR3	Wischerarm Linkslenker	Wiper arm lhd	2
E13MGA-33	Wischerarm Rechtslenker	Wiper arm rhd	2
E14MGA-33	Wischerblatt	Wiper blade	2
E521TR4	Halter Wischwasserflasche	Bracket washer bottle	1
E526SPT	Scheibenwaschpumpe Manuell	Frontscreen washer pump manual	1
E530SPT	Scheibenwaschdüse Chrom	Wiper/wash jet chrome	2
E532SPT	Kunststoffschlauch 3/16" (je Meter)	Plastic wiper washer tubing jets (per meter)	A/R
E35MGA-32	Kunststoffschlauch 1/4 " (je Meter)	Plastic wiper washer tubing jets (per meter)	A/R
E531SPT	T-Verbindungsstück Kunststoffschlauch	T-way wiper washer tubing	1
E520SPT	Flasche Wischwasser (einschl. Deckel)	Wiper wash bottle round (incl. cover)	1

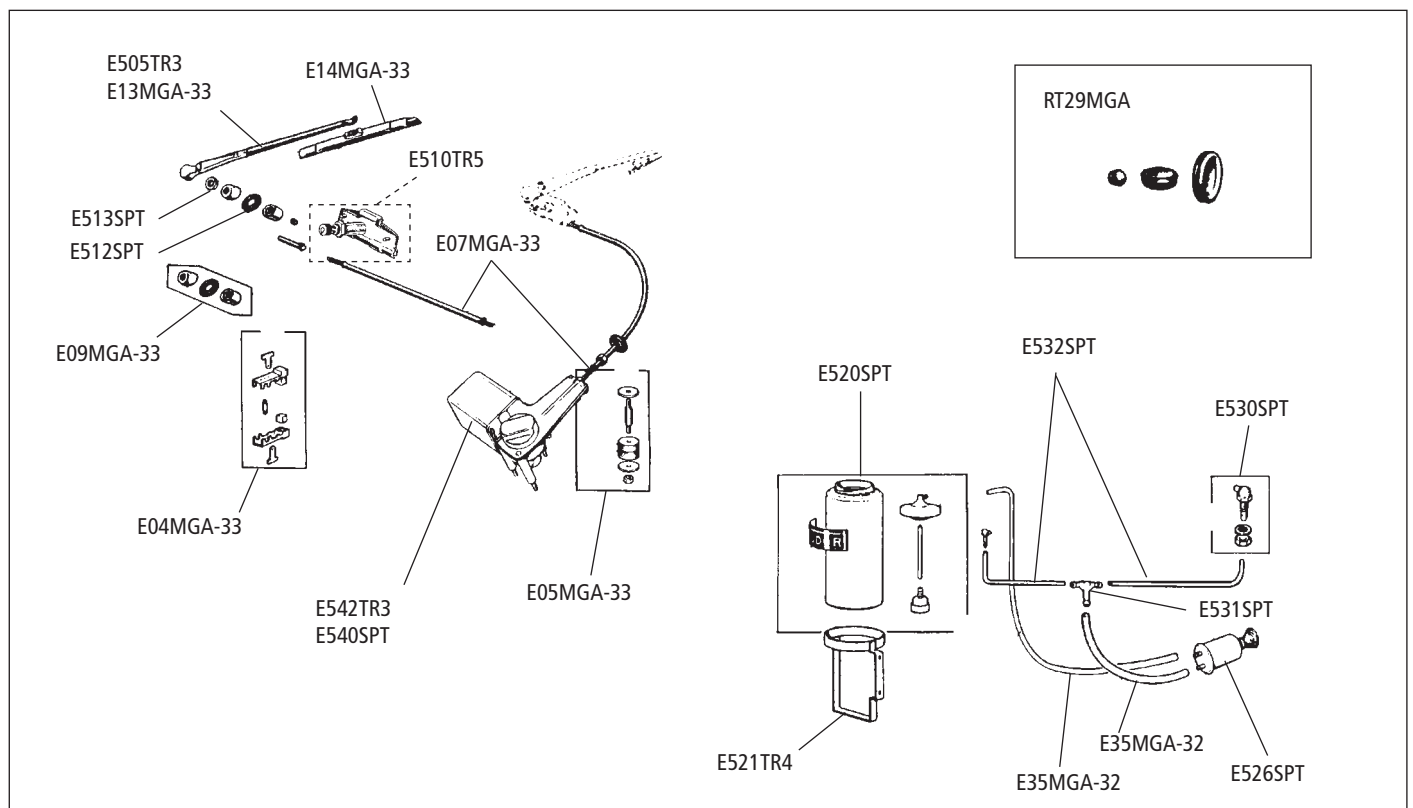

No.	Bezeichnung	Description	Anzahl/Qty.
R1MGA	Frontscheibe Roadster	Frontscreen roadster	1
R1MGA-C	Frontscheibe Coupé	Frontscreen coupe	1
R02MGA-37	Dichtgummi Frontscheiben-Enden	Packing piece frontscreen end	2
R03MGA-37	Dichtgummisatz Frontscheibe /Rahmen	Rubber frontscreen/frame	1
S04MGA-37	Winkel Frontscheibenrahmen unten	Frontscreen corner bracket	2
S05MGA-37	Schraubensatz Frontscheibe (60 tlg)	Bolt kit frontscreen (60 pcs)	1
S06MGA-37	Verdeckwinkel oben rechts	Hood corner peg frontscreen right hand	1
S07MGA-37	Verdeckwinkel oben links	Hood corner peg frontscreen left hand	1
S08MGA-37	Stütze Scheibenrahmen rechts	Frontscreen grab handle right hand	1
S09MGA-37	Stütze Scheibenrahmen links	Frontscreen grab handle left hand	1
S10MGA-37	Befestigungsschraube Stütze/Rahmen	Screw frontscreen grab handle /frame	6
S11MGA-37	Befestigungsschraube Stütze/Karosserie	Screw frontscreen grab handle /body	4
S12MGA-37	Hutmutter Stütze Scheibenrahmen	Dome nut frontscreen pillar	6
S13MGA-37	Unterlage Stütze Scheibenrahmen	Grab handle packing	2
S14MGA-37	Unterlage Scheibenrahmen/Türpfosten (paar)	Packing frontscreen post (pair)	1
S15MGA-37	Frontscheibenpfosten rechts	Frontscreen post right hand	1
S16MGA-37	Frontscheibenpfosten links	Frontscreen post left hand	1
R18MGA-37	Dichtung Frontscheibenpfosten/Karosserie	Grommet frontscreen post/body	2
S3/8"X11/4"	Befestigungsschraube Frontscheibenpfosten/Karosserie	Bolt frontscreen post/body	4
S20MGA-37	Gewindeplatte Scheibenrahmen	Frontscreen tapping plate	2
R9TR3	Dichtung unter Frontscheibenrahmen	Rubber under frontscreen	1
S26MGA-37	Zierleiste Scheibengummi Coupé vorne/hinten	Finisher frontscreen rubber coupe	2
S27MGA-37	Verbindungsclip Zierleiste	Finisher frontscreen rubber coupe	4
R29MGA-37	Frontscheibendichtung Coupé	Frontscreen rubber coupe	1
R30MGA-37	Heckscheibendichtung Coupé	Rear screen rubber coupe	1
R35MGA-37	Paar Steckfenster (mit Alu.-Rahmen, perfekte Passform)	Pair side screens (alloy frame, perfect fit)	1
R36MGA-37	Paar Steckfenster 1500 schwarz Vinyl	Pair side screens 1500 black vinyl	1
R37MGA-37	Paar Steckfenster 1600 schwarz Canvas-Stoff	Pair side screens 1600 black canvas hooding	1
R38MGA-37	Paar Steckfenster 1600 schwarz Vinyl	Pair side screens 1600 black vinyl	1
S41MGA-37	Befestigungsplatte Steckfenster	Side screen attachment plate	2
S42MGA-37	Schraube Befestigungsplatte	Screw side screen attachment plate	6
S43MGA-37	Befestigungsmutter 1500	Screw side screen attachment nut 1500	2
S44MGA-37	Befestigungsmutter 1600	Screw side screen attachment nut 1600	2
R5TR3	Aero Screen (Stück)	Aero Screen (1 piece)	2
R5aMGA	Windabweiser (Paar)	Side wind wings (pair)	1
i59TR3	Sonnenblende Plexiglas, getönt (Stück)	Plexiglas sun visor, green tinted (1 piece)	2

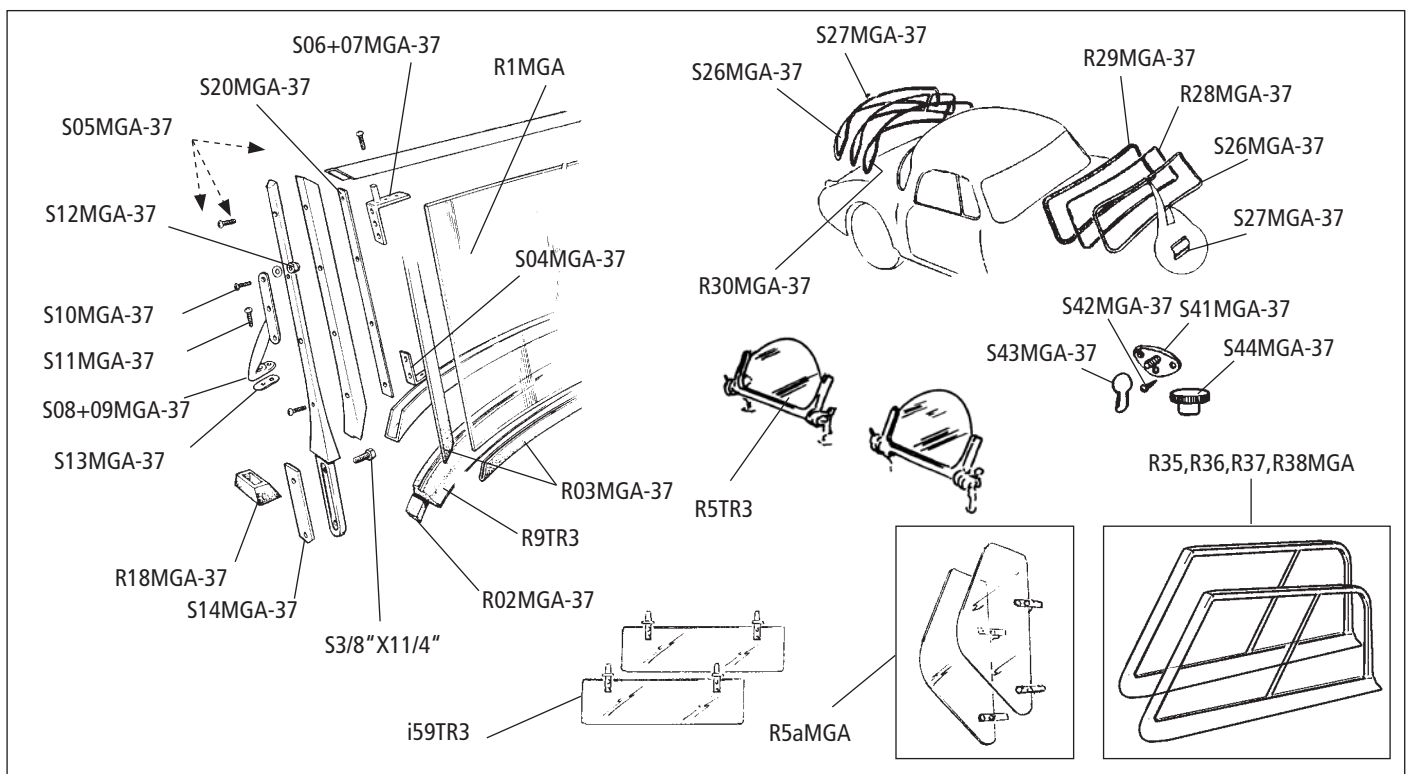

No.	Bezeichnung	Description	Anzahl/Qty.
Coupé		Coupe	
R01MGA-38	Dichtung Ausstellfenster rechts	1/4-light seal right hand	1
R02MGA-38	Dichtung Ausstellfenster links	1/4-light seal left hand	1
R03MGA-38	Glas Ausstellfenster	Glass 1/4-light	2
S04MGA-38	Scharnier Ausstellfenster rechts	Hinge 1/4-light window right hand	1
S05MGA-38	Scharnier Ausstellfenster links	Hinge 1/4-light window left hand	1
S06MGA-38	Gewellte Unterlegscheibe	Anti rattle washer	2
S07MGA-38	Stift Ausstellfenstergriff	1/4-light pin	2
S08MGA-38	Gegenstück Ausstellfensterverriegelung	Pivot 1/4-light	2
R09MGA-38	Abdichtgummi Seitenscheibe außen (Regenabstreifleiste)	Glazing rubber door window outer	2
R10MGA-38	Satz Filzstreifen Führung Seitenscheibe (für 2 Scheiben)	Felt strip set glass channel (2 windows)	1
R11MGA-38	Türscheibe	Door glass	2
R12MGA-38	Filzleiste Seitenscheibe innen	Felt weatherstrip door window inner	2
S13MGA-38	Verschlusshebel rechts	1/4-light handle right hand	1
S14MGA-38	Verschlusshebel links	1/4-light handle left hand	1
R15MGA-38	Klemmgummi Ausstellfenster (für 2 Ausstellfenster)	Glazing rubbers 1/4-light windows (for 2 windows)	1
S16MGA-38	Türgriff außen	Door handle exterior	2
S17MGA-38	Türfangplatte rechts	Door striker right hand	1
S18MGA-38	Türfangplatte links	Door striker left hand	1
S19MGA-38	Türgriff innen (original)	Door handle interior (original)	2
S20MGA-38	Türgriff innen (Zubehör)	Door handle interior (replacement)	2
S21MGA-38	Fensterkurbel	Regulator handle chrome	2
S22MGA-38	Unterlagscheibe Türgriff/Fensterkurbel	Handle escutcheon	4
S25MGA-38	Türschließzylinder (Fahrtür)	Barrel and key drivers door	1
R26MGA-38	Sonnenblende Cabrio/Coupé schwarz	Sun visor black	2
R27MGA-38	Sonnenblende Cabrio/Coupé weiß	Sun visor white	2
Roadster		Roadster	
i09MGB-40	Holzleiste Türoberkante rechts	Door top wooden rail right hand	1
i10MGA-40	Holzleiste Türoberkante links	Door top wooden rail left hand	1
S27AMGB-27	Türfangkeil	Door lock striker	2
S30MGA-38	Chromhülse Steckfenster	Sidescreen socket	2
R31MGA-38	Scheibe Chromhülse	Washer sidescreen socket	2
HM1/2"	Kontermutter	Nut	2
S35MGA-38	Alu-Ecke Türoberkante rechts	Door corner rail aluminium right hand	1
S36MGA-38	Alu-Ecke Türoberkante links	Door corner rail aluminium left hand	1
S38MGA-38	Türschließ-Mechanismus rechts	Door latch right hand	1
S39MGA-38	Türschließ-Mechanismus links	Door latch left hand	1
S40MGA-38	Zugkabel Türöffner	Door pull cable	2
R41MGA-38	Gummitülle Zugkabel	Grommet door pull cable	2
S42MGA-38	Türscharnier	Door hinge	4
SR8	Senkkopfschraube Türscharnier/Türfangplatten 1/4" x 1"	Countersunk screw door hinges/door catch plates 1/4" x 1"	32
S45MGA-38	Versteifung Türverkleidung	Stiffener bar door panel	2
S46MGA-38	Gewindeplatte Türkeil	Tapping plate door striker	2
S47MGA-38	Gewindeplatte Türscharnier	Tapping plate door hinge	4
S48MGA-38	Unterlagscheibe Türscharnier	Packing shim door hinge	A/R
S49MGA-38	Unterlagscheibe Türkeil	Packing shim door striker	A/R
S51MGA-03	Türanschlaggummi hinterer Türpfosten	Buffer door on b-post	4

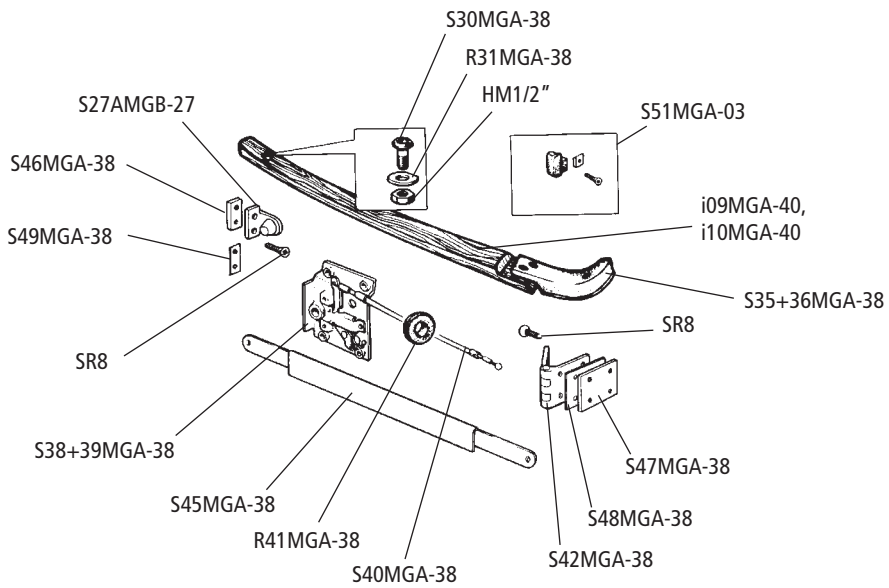
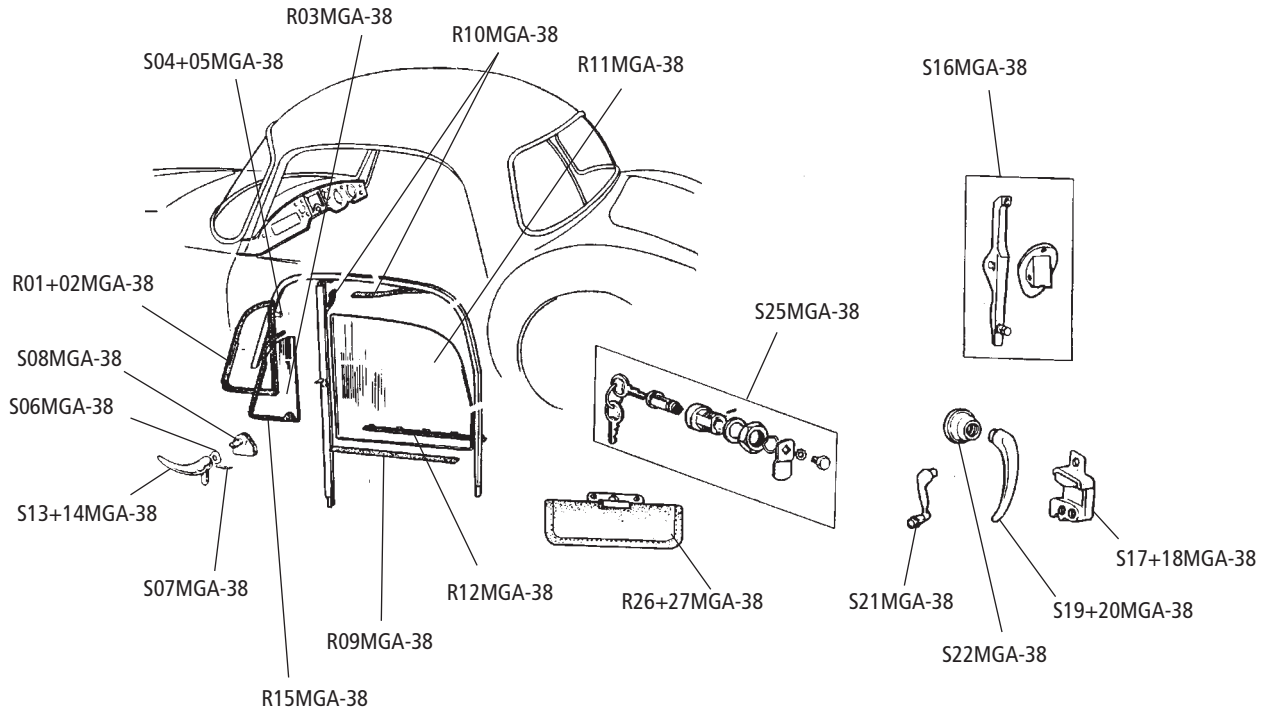

No.	Bezeichnung	Description	Anzahl/Qty.
KA01MGA-04	Kofferraumboden	Boot floor	1
KA02MGA-04	Reparatur- Blech Kofferraumboden Mitte	Repair panel boot floor centre	1
KA03MGA-04	Reparatur- Blech Kofferraumboden hinten	Repair panel boot floor rear	1
KA04MGA-04	Feder Schnellverschuß	Dzus spring	2
KA05MGA-04	Schnellverschuß Batterieabdeckung	Dzus fastener	2
KA06MGA-04	Batterieabdeckung 1500/1600	Battery cover 1500/1600	1
KA07MGA-04	Batterieabdeckung 1600 MK2	Battery cover 1600 MK2	1
KA08MGA-04	Rückwand Innenraum (außer 1600 Coupé)	Rear bulkhead panel (except 1600 coupe)	1
KA09MGA-04	Schweller A- und B-Pfosten Roadster rechts	Sill a- and b-post pillar roadster right hand	1
KA10MGA-04	Schweller A- und B-Pfosten Roadster links	Sill a- and b-post pillar roadster left hand	1
KA11MGA-04	Schweller A- und B-Pfosten Coupé rechts	Sill a- and b-post pillar coupe right hand	1
KA12MGA-04	Schweller A- und B-Pfosten Coupé links	Sill a- and b-post pillar coupe left hand	1
KA13MGA-04	B-Pfosten Roadster rechts	B-post pillar roadster right hand	1
KA14MGA-04	B-Pfosten Roadster links	B-post pillar roadster left hand	1
KA15MGA-04	B-Pfosten Coupé rechts	B-post pillar coupe right hand	1
KA16MGA-04	B-Pfosten Coupé links	B-post pillar coupe left hand	1
KA17MGA-04	A-Pfosten rechts	A-post pillar right hand	1
KA18MGA-04	A-Pfosten links	A-post pillar left hand	1
KA19MGA-04	Innenschweller mit Endkappen rechts	Inner sill with end caps right hand	1
KA20MGA-04	Innenschweller mit Endkappen links	Inner sill with end caps left hand	1
KA21MGA-04	Inneres Schwellerstehblech rechts	Sill closing panel inner right hand	1
KA22MGA-04	Inneres Schwellerstehblech links	Sill closing panel inner left hand	1
KA23MGA-04	Abdeckblech Schweller rechts	Sill cover plate right hand	1
KA24MGA-04	Abdeckblech Schweller links	Sill cover plate left hand	1
KA25MGA-04	Verstärkungsschiene	Reinforcing channel	2
KA26MGA-04	Satz Aluleisten Türschweller (2-tlg)	Finisher set sill (2 pcs)	1
KA27MGA-04	Außenschweller rechts	Outer sill panel right hand	1
KA28MGA-04	Außenschweller links	Outer sill panel left hand	1
KA01MGA-05	Spritzblech vorne rechts	Splash plate front right hand	1
KA02MGA-05	Spritzblech vorne links	Splash plate front left hand	1
KA03MGA-05	Spritzblech vorne rechts "Zubehör" *	Splash plate front right hand (alternative) *	1
KA04MGA-05	Spritzblech vorne links "Zubehör" *	Splash plate front left hand (alternative) *	1
KA05MGA-05	Spritzblech Kotflügel hinten vorne rechts	Splash plate rear wing front right hand	1
KA06MGA-05	Spritzblech Kotflügel hinten vorne links	Splash plate rear wing front left hand	1
KA07MGA-05	Spritzblech Kotflügel hinten vorne rechts "Zubehör" *	Splash plate rear wing front right hand (alternative) *	1
KA08MGA-05	Spritzblech Kotflügel hinten vorne links "Zubehör" *	Splash plate rear wing front left hand (alternative) *	1
KA30MGA-04	Original Dichtgummi Spritzblech vorne rechts	Original splash seal front right hand	1
KA31MGA-04	Original Dichtgummi Spritzblech vorne links	Original splash seal front left hand	1
KA07MGA-27	Zubehör Dichtgummi Spritzblech vorne (für links oder rechts) *	Alternative splash seal front - push on (for lh or rh) *	2
KA33MGA-04	Original Dichtgummi Spritzblech hinten rechts	Original splash seal rear right hand	1
KA34MGA-04	Original Dichtgummi Spritzblech hinten links	Original splash seal rear left hand	1
KA35MGA-04	Zubehör Dichtgummi Spritzblech hinten (für links oder rechts) *	Alternative splash seal rear - push on (for lh or rh) *	2
KA36MGA-04	Satz Befestigungsnieten „Original“ Spritzblech (64 tlg)	Split pins set for original splash seal (64 pcs)	1
KA37MGA-04	Befestigungsniete „Original“ Spritzblech	Split rivet pins for „original“ splash seal	4
KA38MGA-04	Reparatur-Teil Radkastenstrebe rechts	Rep.-panel wheel arch brace right hand	1
KA39MGA-04	Reparatur-Teil Radkastenstrebe links	Rep.-panel wheel arch brace left hand	1
KA40MGA-04	Winkelblech rechts	Rep.-piece sill to wheel well right hand	1
KA41MGA-04	Winkelblech links	Rep.-piece sill to wheel well left hand	1
KA42MGA-04	Schließblech Radlauf rechts	Wheelarch closing panel right hand	1
KA43MGA-04	Schließblech Radlauf links	Wheelarch closing panel left hand	1
KA44MGA-04	Verstärkung Radlauf rechts	Reinforcement wheel well right hand	1
KA45MGA-04	Verstärkung Radlauf links	Reinforcement wheel well left hand	1

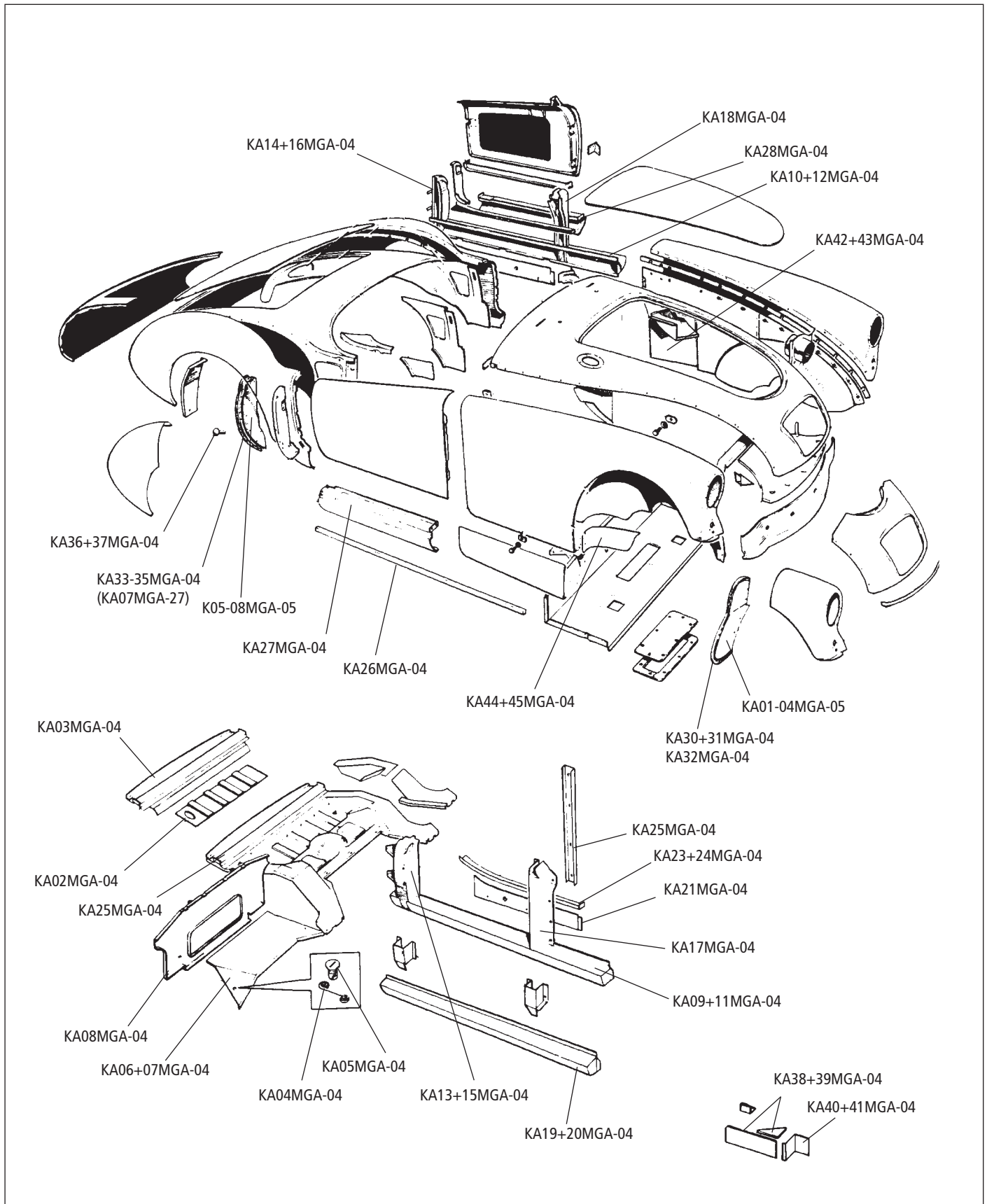

Hinweis 
Note:

* Anmerkung zu Nr. KA03/04/07/08MGA-05 und KA32/35MGA-04: Diese Dichtgummis werden auf die Spritzbleche einfach „aufgedrückt“.

* Note to no KA03/04/07/08MGA-05 and KA32/35MGA-04: These alternative splash seal are fitted with a „push-on“ clamp fitting.

No.	Bezeichnung	Description	Anzahl/Qty.
KA09MGA-05	Abschlußblech B-Säule Roadster rechts	Shut face panel roadster right hand	1
KA10MGA-05	Abschlußblech B-Säule Roadster links	Shut face panel roadster left hand	1
KA11MGA-05	Abschlußblech B-Säule Coupé rechts	Shut face panel coupe right hand	1
KA12MGA-05	Abschlußblech B-Säule Coupé links	Shut face panel coupe left hand	1
KA13MGA-05	Spritzblech Kotflügel hinten, rechts hinten	Splash plate rear wing rear right hand	1
KA14MGA-05	Spritzblech Kotflügel hinten, links hinten	Splash plate rear wing rear left hand	1
KA15MGA-05	Kofferraumdeckel	Boot lid	1
KA16MGA-05	Kofferraumdeckel-Außenhaut	Boot lid outer skin	1
KA17MGA-05	Kofferraum-Abdeckblech Roadster	Tonneau panel roadster	1
KA18MGA-05	Reparatur-Blech Abdeckblech rechts	Repair panel rear deck right hand	1
KA19MGA-05	Reparatur-Blech Abdeckblech links	Repair panel rear deck left hand	1
KA20MGA-05	Heckblech	Rear valance	1
KA21MGA-05	Kotflügel hinten rechts	Rear wing right hand	1
KA22MGA-05	Kotflügel hinten links	Rear wing left hand	1
KA22AMGA-05	Satz Befestigungsschrauben Kotflügel hinten	Rear wing bolt kit	2
KA23MGA-05	Reparatur-Blech Kotflügel hinten, rechts hinten	Repair panel rear wing rear right hand	1
KA24MGA-05	Reparatur-Blech Kotflügel hinten, links hinten	Repair panel rear wing rear left hand	1
KA25MGA-05	Reparatur-Blech Kotflügel hinten, rechts vorne	Repair panel rear wing front right hand	1
KA26MGA-05	Reparatur-Blech Kotflügel hinten, links vorne	Repair panel rear wing front left hand	1
KA27MGA-05	Reparatur-Blech Kotflügel hinten, rechts vorne, unten	Repair panel rear wing front lower right hand	1
KA28MGA-05	Reparatur-Blech Kotflügel hinten, links vorne, unten	Repair panel rear wing front lower left hand	1
KA29MGA-05	Kotflügel vorne rechts	Front wing right hand	1
KA30MGA-05	Kotflügel vorne links	Front wing left hand	1
KA31MGA-05	Reparatur-Blech Kotflügel vorne, rechts unten	Repair panel front wing lower right hand	1
KA32MGA-05	Reparatur-Blech Kotflügel vorne, links unten	Repair panel front wing lower left hand	1
KA33MGA-05	Satz Befestigungsschrauben,-scheiben Kotflügel vorne	Front wing bolt and washer kit	2
KA41AMGB-27	Unterlegscheibe unten	Wing washer plate upper	6
KA35MGA-05	Unterlegscheibe oben	Wing washer plate lower	22
KA36MGA-05	Reparatur-Blech Kotflügel vorne, rechts vorne	Repair panel front wing lamp section right hand	1
KA37MGA-05	Reparatur-Blech Kotflügel vorne, links vorne	Repair panel front wing lamp section left hand	1
KA38MGA-05	Motorhaube (Späte Ausführung, Leicht Gewölbt)	Bonnet late type with slight bulge	1
KA39MGA-05	Halter Lufteinlaß-Schlauch rechts	Bracket air inlet hose right hand	1
KA40MGA-05	Halter Lufteinlaß-Schlauch links	Bracket air inlet hose left hand	1
KA41MGA-05	Lufteinlaß-Kasten rechts	Air duct box right hand	1
KA42MGA-05	Lufteinlaß-Kasten links	Air duct box left hand	1
KA43MGA-05	Aufkleber (BMC Rosette) für Karosserie	Sticker (BMC rosette) for body	1

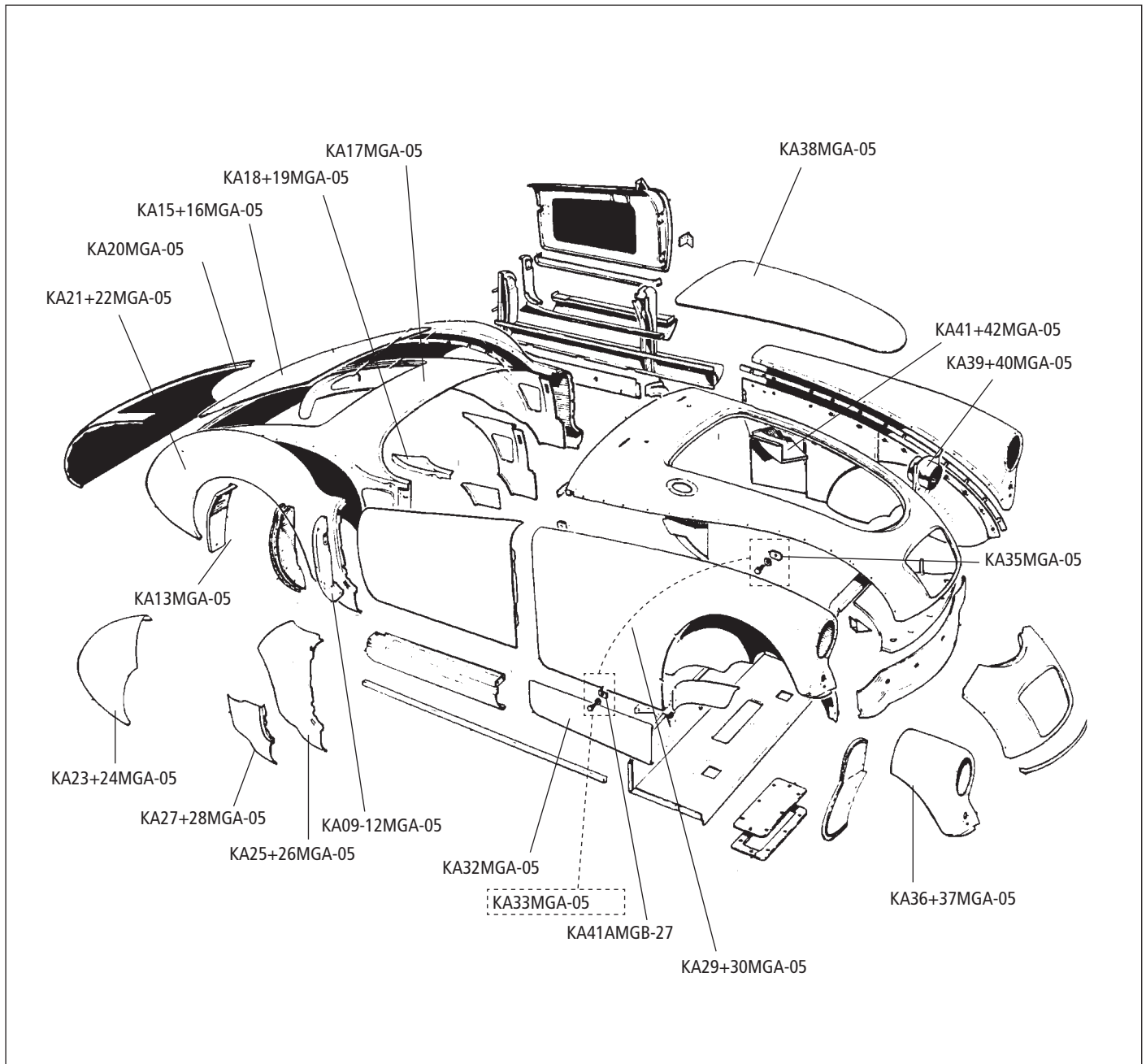

No.	Bezeichnung	Description	Anzahl/Qty.
KA01MGA-06	Frontblech Roadster	Front shroud roadster	1
KA02MGA-06	Abdeckkappe oben rechts	Pillar top extension right hand	1
KA03MGA-06	Abdeckkappe oben links	Pillar top extension left hand	1
KA04MGA-06	Reparatur-Blech Frontblech	Repair panel front shroud	2
KA05MGA-06	Frontschürze Stahl	Front valance steel	2
KA06MGA-06	Frontschürze Polyester	Front valance fibreglass	1
KA07MGA-06	Luftleinlaßblech 1500/1600	Lower duct panel MGA1500/1600	1
KA08MGA-06	Luftleinlaßblech 1600 MK2	Lower duct panel MGA1600 MK2	1
KA09MGA-06	Halte Luftleinlaßblech rechts	Radiator duct bracket right hand	1
KA10MGA-06	Halte Luftleinlaßblech links	Radiator duct bracket left hand	1
KA11MGA-06	Spritzwand	Bulkhead assembly	1
KA12MGA-06	Reparatur-Blech Spritzwand	Repair panel bulkhead	1
KA13MGA-06	Abschlußleiste Frontblech zur Frontschürze	Skirt panel	1
KA14MGA-06	Türe Roadster rechts	Door roadster right hand	1
KA15MGA-06	Türe Roadster links	Door roadster left hand	1
KA16MGA-06	Türhaut Roadster rechts	Door skin roadster right hand	1
KA17MGA-06	Türhaut Roadster links	Door skin roadster left hand	1
KA18MGA-06	Türhaut Coupé rechts	Door skin coupe right hand	1
KA19MGA-06	Türhaut Coupé links	Door skin coupe left hand	1
KA20MGA-06	Reparatur-Blech Türe innen Roadster rechts	Repair panel inner door roadster right hand	1
KA21MGA-06	Reparatur-Blech Türe innen Roadster links	Repair panel inner door roadster left hand	1
KA22MGA-06	Reparatur-Blech Türe innen Coupé rechts	Repair panel inner door coupe right hand	1
KA23MGA-06	Reparatur-Blech Türe innen Coupé links	Repair panel inner door coupe left hand	1
KA24MGA-06	Abdeckplatte Heizung (bei nicht montierter Heizung)	Blanking plate (if heater not fitted)	1
K07MGA-32	Dichtung Abdeckplatte Heizung	Seal blanking plate heater	2
KA25MGA-06	Holzbodensatz 1500 bis 61504 (7 tlg)	Floorboard set 1500 up to 61504 (7 pcs)	1
KA26MGA-06	Holzbodensatz 1500 Ab 61605/1600/1600 MK2 (7 tlg)	Floorboard set 1500 from 61505/1600/1600 MK2 (7 pcs)	1
KA27MGA-06	Holzbodensatz Bodenbereich (5 tlg)	Main floorboard set (5 pcs)	1
KA28MGA-06	Dichtung	Seal	1
KA29MGA-06	Satz Befestigungsschrauben/Scheiben Holzbodensatz	Screw/washer kit floor panels	1
KA30MGA-06	Satz Chassisauflagegummis (28 tlg)	Packing set body mounting (28 pcs)	1
KA31MGA-06	Reparaturteil Träger Bodenplatten	Repair panel floorboard rail	1
KA32MGA-06	Reparaturteil Chassis seitlich	Repair panel side of chassis	2
KA33MGA-06	Batterieträger rechts	Battery bracket right hand	1
KA34MGA-06	Batterieträger links	Battery bracket left hand	1
KA35MGA-06	Batterieträger Boden	Battery floor panel	2
KA36MGA-06	Verlängerung Chassis vorne	Chassis extension front	1
KA37MGA-06	Aufhängung Stoßstange vorne rechts	Bracket, front bumper right hand	1
KA38MGA-06	Aufhängung Stoßstange vorne links	Bracket, front bumper left hand	1
KA40MGA-06	Aufhängung Stoßstange hinten rechts	Bracket, rear bumper right hand	1
KA41MGA-06	Aufhängung Stoßstange hinten links	Bracket, rear bumper left hand	1
KA42MGA-06	Chassis-Farbe „schwarz emailiert“ (500 ml)	Chassis-paint „black enamel“ (500 ml)	A/R
KA43MGA-06	Dichtung Blech Schaltung	Gasket gear lever panel	1
KA44MGA-06	Gummiabdeckung Anlasserritzel	Rubber cover starter drive	1
KA45MGA-06	Plakette Fahrgestell „Patents No“	Chassis plate „Patents No“	1
KA41SPT	Blanko Typenschild	Universal identification plate	1
KA46MGA	Dichtgummi seitlich Getriebetunnel	Buffer	2
S15MGA-02	Deckel Getriebe-Ölpeilstab	Trans. cover plug	1

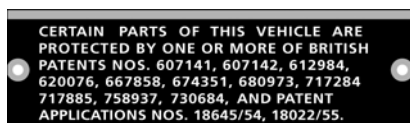

KA45MGA-06



KA41SPT

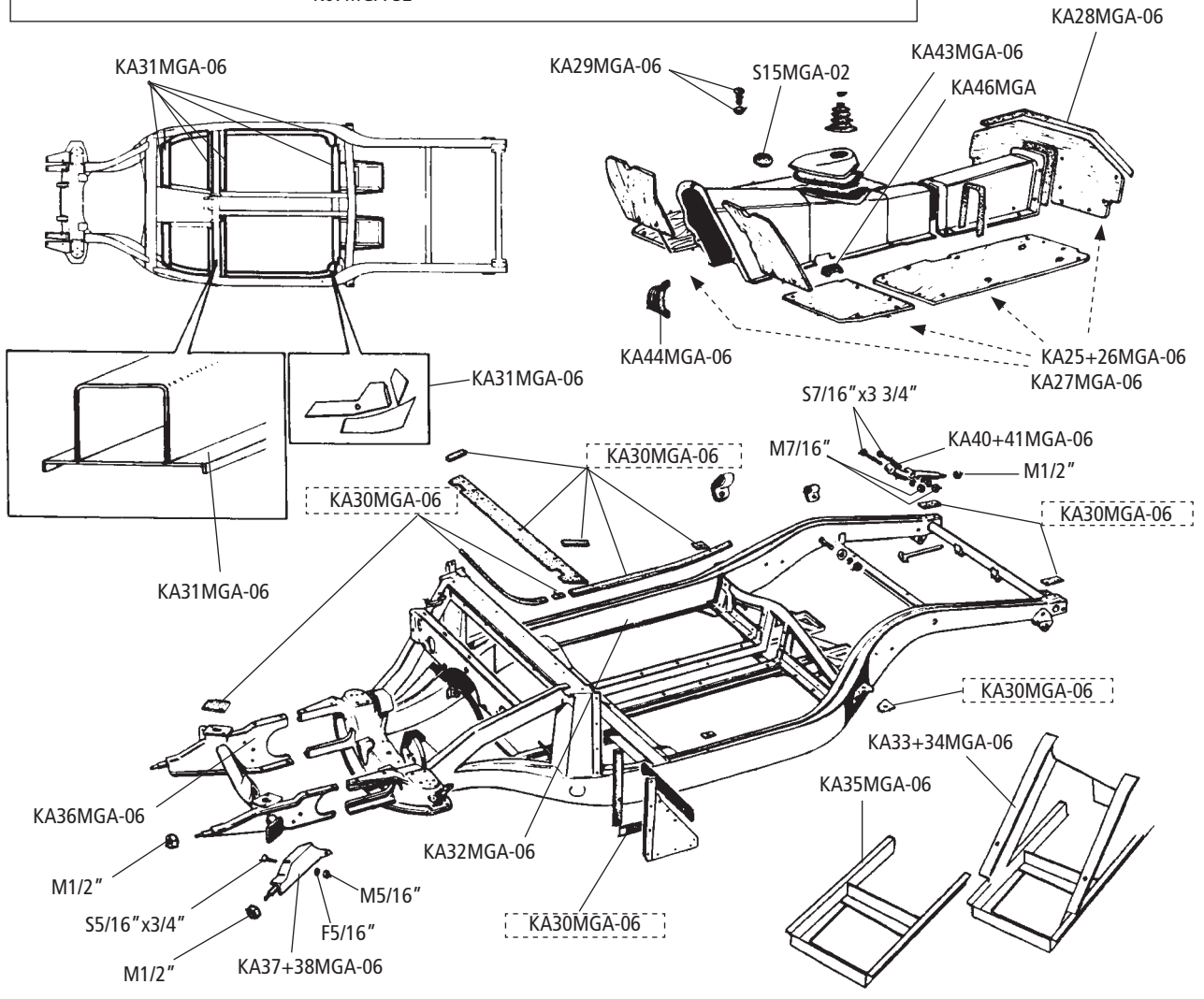
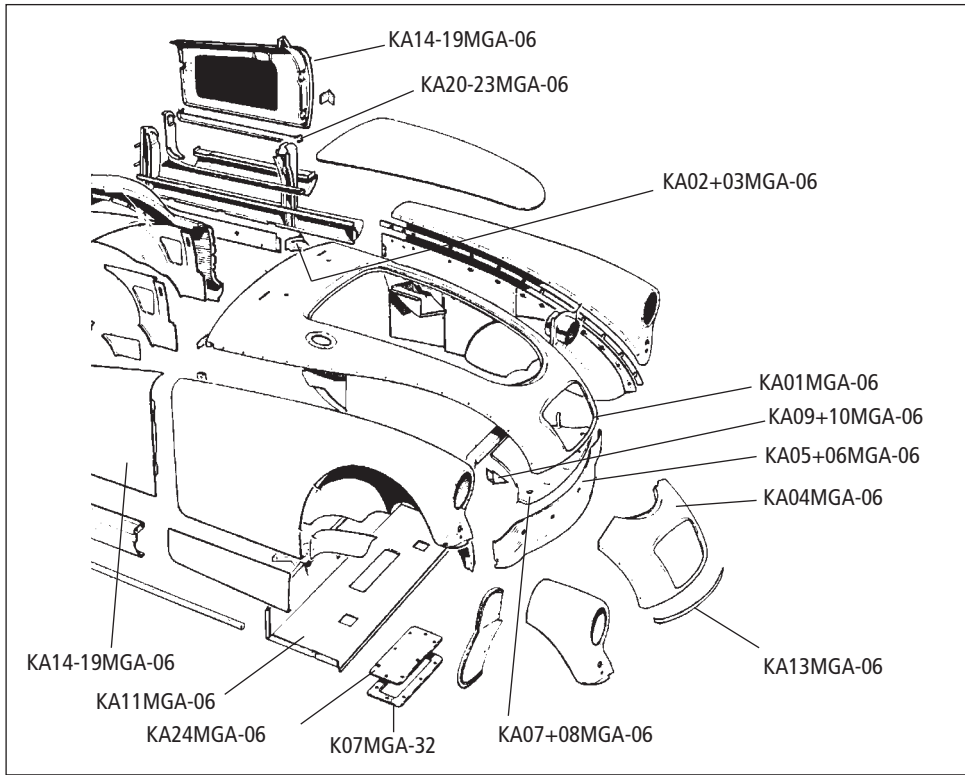

No.	Bezeichnung	Description	Anzahl/Qty.
i01MGA-39	Verdeckgestänge	Hood frame	1
i02MGA-39	Verdeckleiste vorne	Hood header rail	1
i03MGA-39	Flügelschraube Verdeck vorne	Wing bolt hood fixing	2
i04MGA-39	Führungshülse Verdeckleiste vorne	Socket header rail	2
i05MGA-39	Verdeckleiste hinten	Rear hood retainer	1
i06MGA-39	Verdeck (3 Fenster) 1500/1600 Vinyl schwarz	Hood (3 windows) 1500/1600 vinyl black	1
i07MGA-39	Verdeck (3 Fenster) 1500/1600 Duck schwarz	Hood (3 windows) 1500/1600 duck black	1
i07AMGA-39	Verdeck (3 Fenster) 1500/1600 Mohair schwarz	Hood (3 windows) 1500/1600 mohair black	1
i12MGA-39	Verdeck (3 Fenster) 1600 MK2 Vinyl schwarz	Hood (3 windows) 1600/MK2 vinyl black	1
i13MGA-38	Verdeck (3 Fenster) 1600 MK2 Duck schwarz	Hood (3 windows) 1600/MK2 duck black	1
i14MGA-39	Verdeck (3 Fenster) 1600 MK2 Mohair schwarz	Hood (3 windows) 1600 MK2 mohair black	1
i20MGA-39	Oberer Ring für Drehverschluß	Upper eyelet for turn button	2
i21MGA-39	Unterer Ring für Drehverschluß	Lower eyelet for turn button	2
i23AMGA-39	Lederscheibe unter Verdeckstift	Leather washer under rear tonneau peg	A/R
i25MGA-39	Drehverschluß	Turn button	A/R
i26MGA-39	Chromhalterung Verdeckleiste	Rear hood retainer chrome	2
i28MGA-39	Verdeckverschluß vorne am Verdeckbalken 1600 + MK2	Centre latch header rail 1600 + MK2	1
i29MGA-39	Aufnahme Verdeckverschluß am Frontscheibenrahmen	Hood catch	1
i30MGA-39	Spritzdecke „kurz“ Linkslenker Vinyl schwarz	Tonneau cover lhd „short“ Vinyl black	1
i31MGA-39	Spritzdecke „kurz“ Linkslenker Duck schwarz	Tonneau cover lhd „short“ Duck black	1
i32MGA-39	Spritzdecke „kurz“ Linkslenker Mohair schwarz	Tonneau cover lhd „short“ Mohair black	1
i36MGA-39	Spritzdecke „lang“ Linkslenker Vinyl schwarz	Tonneau cover lhd „long“ Vinyl black	1
i37MGA-39	Spritzdecke „lang“ Linkslenker Duck schwarz	Tonneau cover lhd „long“ Duck black	1
i38MGA-39	Spritzdecke „lang“ Linkslenker Mohair schwarz	Tonneau cover lhd „long“ Mohair black	1
i43MGA-39	Befestigungsschraube Spritzdeckenhalter	Round head Setscrew	A/R
S49MGA-03	Unterlegdeckel Chromhalterung	Washer cup rear retaining plate	2
i113	Verdeckstift	Peg rear tonneau fixing	A/R
i114	Spritzdecken-Halter	Peg fastener	A/R
i115	Verdeckstift (Holzgewinde) (kurze Spritzdecke)	Peg (wood taper)(short tonneau cover)	A/R
i116	Lift The Dot Ober- und Unterteil	Lift the dot hood fastener upper and lower	6
i117	Kontermutter Verdeckstift (Nr. i23AMGA-39)	Nut for tonneau peg (no. i23AMGA-39)	A/R

Farbige Verdecke und Abdeckungen auf Anfrage!

More colours for hoods and tonneaus on demand!

Hinweis
Note:



Anmerkung:
Verdecke 1500 mit 1 Fenster sind auf Bestellung ebenfalls lieferbar. Alle Verdecke werden mit den entsprechenden Befestigungsknöpfen verdeckseitig geliefert.

Unsere Spritzdecken werden mit allen Befestigungsknöpfen spritzdeckenseitig geliefert. Die Spritzdecken verfügen selbstverständlich über einen Mittelreißverschluß und sind auch für rechtsgelenkte Fahrzeuge lieferbar.

Note:

Hoods 1500 with 1 rear window are also available. Every hoods contents all fitting materials.

Every tonneau cover contents all fitting materials (for the tonneau). All tonneau have a centre zip and are also available for rhd cars.

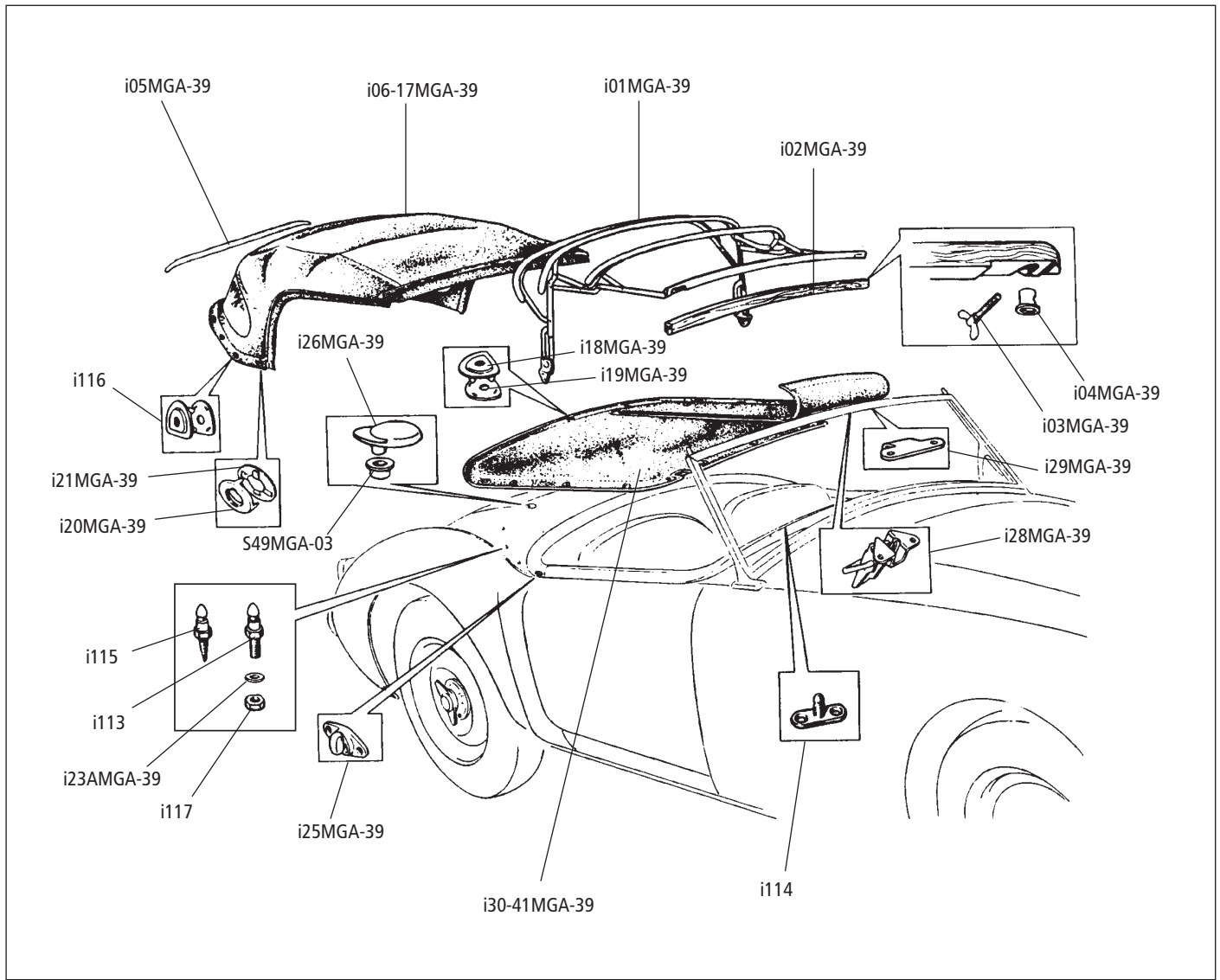

No.	Bezeichnung	Description	Anzahl/Qty.
i01MGA-40	Satz Armaturenblech-Leisten (mit Gummis, Endkappen, Bolzen)	Dash rail set (with rubbers, end caps, bolts)	1
i02MGA-40	Gummistreifen Armaturenblech	Rubber strip dashboard	1
i03MGA-40	T-Bolzen	T-bolt	6
i09MGA-40	Holzleiste Türoberkante rechts	Door top rail wood right hand	1
i10MGA-40	Holzleiste Türoberkante links	Door top rail wood left hand	1
i11MGA-40	Holzleiste Fahrgastraum hinten	Rear cockpit rail wood	1
i12MGA-40	Befestigung-Set Holzleiste hinten	Hardware set rear cockpit rail	1
i13MGA-40	Aluminium-Ecke Fahrgastraum hinten rechts	Corner rail aluminium rear right hand	1
i14MGA-40	Aluminium-Ecke Fahrgastraum hinten links	Corner rail aluminium rear left hand	1
i15MGA-40	Satz Chrom Endkappen Türdichtung (4 tlg)	Set seal finishers (4 pcs)	1
i16MGA-40	Chrom Endkappe hinten rechts	Rear seal finisher right hand	1
i16AMGA-40	Chrom Endkappe hinten links	Rear seal finisher left hand	1
i17MGA-40	Chrom Endkappe vorne rechts	Front seal finisher right hand	1
i17AMGA-40	Chrom Endkappe vorne links	Front seal finisher left hand	1
i18MGA-40	Befestigungsschraube Endkappen	Screw	A/R
i18MGA-39	Lift The Dot-Oberteil	Lift the dot hood fastener	7
i19MGA-39	Lift The Dot-Unterteil	Lift the dot washer	7
i20MGA-40	Steckfenstertasche 1500/1600 bis 78249 schwarz	Sidescreen bag 1500/1600 up to 78249 black	1
i21MGA-40	Steckfenstertasche 1500/1600 bis 78249 rot	Sidescreen bag 1500/1600 up to 78249 red	1
i22MGA-40	Steckfenstertasche 1500/1600 bis 78249 hellbraun	Sidescreen bag 1500/1600 up to 78249 tan	1
i23MGA-40	Steckfenstertasche 1600 ab 78250 + MK2 schwarz	Sidescreen bag 1600 from 78250 + MK2 black	1
i24MGA-40	Steckfenstertasche 1600 ab 78250 + MK2 rot	Sidescreen bag 1600 from 78250 + MK2 red	1
i25MGA-40	Steckfenstertasche 1600 ab 78250 + MK2 hellbraun	Sidescreen bag 1600 from 78250 + MK2 tan	1
i26MGA-40	Steckfenstertasche 1600 ab 78250 + MK2 beige	Sidescreen bag 1600 from 78250 + MK2 beige	1
i27MGA-40	Steckfenstertasche 1600 ab 78250 + MK2 grün	Sidescreen bag 1600 from 78250 + MK2 green	1
i28MGA-40	Steckfenstertasche 1600 ab 78250 + MK2 grau	Sidescreen bag 1600 from 78250 + MK2 grey	1
i29MGA-40	Stauch-Stift Befestigung „Lift The Dot“	Pronged clinch „Lift the dot“	1
i30MGA-40	Gegenscheibe Stauch-Stift „Lift The Dot“	Plate clinch „Lift the dot“	1
S31MGA-02	Aschenbecher mit Chromdeckel	Ashtray with chrome top	1
S35MGA-38	Aluminium-Ecke Türoberkante rechts	Door corner rail aluminium right hand	1
S36MGA-38	Aluminium-Ecke Türoberkante links	Door corner rail aluminium left hand	1
i40MGA-40	Türdichtgummi mit Kunststoff schwarz (je 1,90 Meter)	Door seal rubber black (per 1,9 m)	2
S45MGA-38	Versteifung Türverkleidung	Stiffener bar door panel	2
i114	Befestigungsstift „Lift The Dot“	Peg fastener „Lift the dot“	6
i160	Schraube und Rosette zur Befestigung Innenverkleidungen	Screw and chrom cap washer for fitting interieur trim	A/R
724031M	Türdichtgummi mit Velours schwarz (je Meter)	Draught excluder flurflex black, per meter	2
DER5001M	Türdichtgummi mit Velours rot (je Meter)	Draught excluder flurflex red (per meter)	2

No.	Bezeichnung	Description	Anzahl/Qty.
i30MGAS-41	Teppichsatz vorne schwarz, Roadster + Coupé	Front carpet set nylon black, Roadster + Coupe	1
i30aMGARS-41	Teppichsatz hinten schwarz, Roadster	Rear carpet set black, Roadster	1
i30aMGACS-41	Teppichsatz hinten schwarz, Coupé	Rear carpet set black, Coupe	1
i103	Teppich-Befestigungsclip-Gegenstück auf Karosserie usw.	Stud hood rear (on body)	A/R
i105	Popniete Gegenstück	Rivet imex	A/R
i150	Teppich Druckknopf	Carpet fastener	A/R
i31aMGA-41	Filzdämmmatten Set	Felt mat kit	1
i34MGAS	Kofferraumteppich schwarz, Roadster + Coupé	Boot carpet black, Roadster + Coupe	1
i40MGA-42	Paar Gummifußmatten mit MG Logo	Pair rubber floor mats with MG-logo	1
i116aMGA	Paar Schutzmatte mit MG-Logo	Overmats with MG-logo, pair	1
i01MGA-42	Kappe Reserverad schwarz, alle Roadster + 1500 Coupé	Spare wheel cover black, all Roadster + 1500 Coupe	1
i07MGA-42	Kappe Reserverad schwarz, 1600 + MK2 Coupé	Spare wheel cover black, 1600 + MK2 Coupe	1
i02MGA-42	Umrandung Reserveradabdeckung, alle Roadster + 1500 Coupé	Frame spare wheel cover, all Roadster + 1500 Coupe	1

Farbige Teppichsätze auf Anfrage!

More colours for carpet sets on demand!

(s. auch Seite 98 "Accessoires")

(please refer page 98 "Accessories")

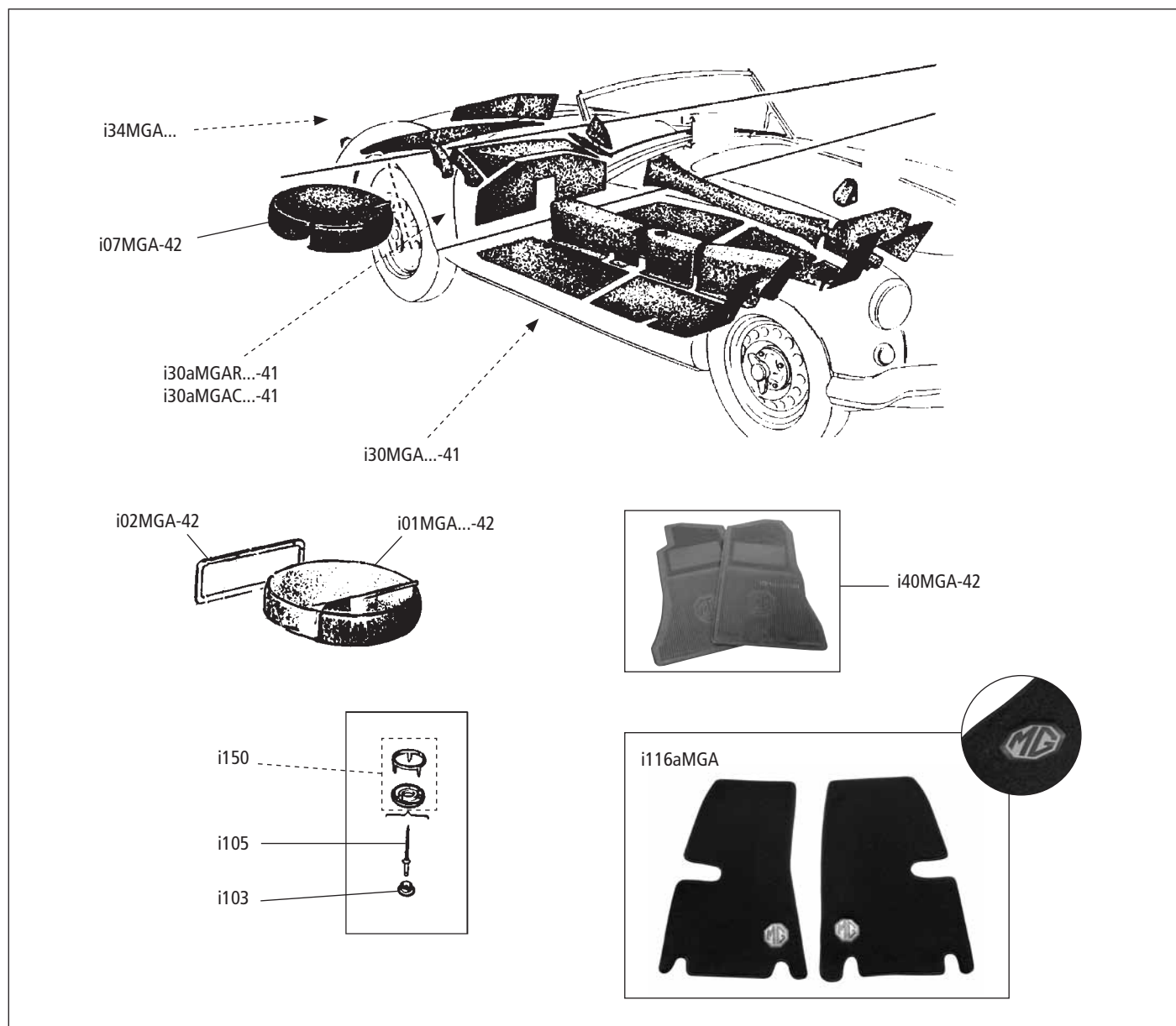

No.	Bezeichnung	Description	Anzahl/Qty.
i28MGA-42	Innenausstattungs-Satz schwarz/weißer Keder, Roadster Paar	Trim kit black/white piping, Roadster	1
i11MGA-43	Türverkleidungen + Taschen schwarz, Roadster	Pair door trim panels black, Roadster	1
i20MGA-43	Innenausstattungs-Satz schwarz/weißer Keder, Coupé	Trim kit black/white piping, Coupe	1
i32MGA-43	Paar Türverkleidungen+Taschen schwarz/weißer Keder, Coupé	Pair door trim panels black/white piping, Coupe	1
i160	Schraube und Rosette zur Befestigung Innenverkleidungen	Screw and chrom cap washer for fitting interieur trim	A/R
i01MGA-44	Armlehnen-Satz Leder schwarz/weißer Keder *	Armrest kit leather black/white piping *	1
i14MGA-44	Armlehnen-Satz Vinyl schwarz/weißer Keder *	Armrest kit vinyl black/white piping *	1

Farbige Innenausstattungen auf Anfrage!

More colours for trim kits on demand!

Hinweis 
Note:

* Anmerkung zu Nr. i01+14MGA-44: Armlehnen-Satz enthält Abdeckung und Schaumgummi!

* Note to no. i01+14MGA-44: Armrest kit contents cover and armrest foam part!

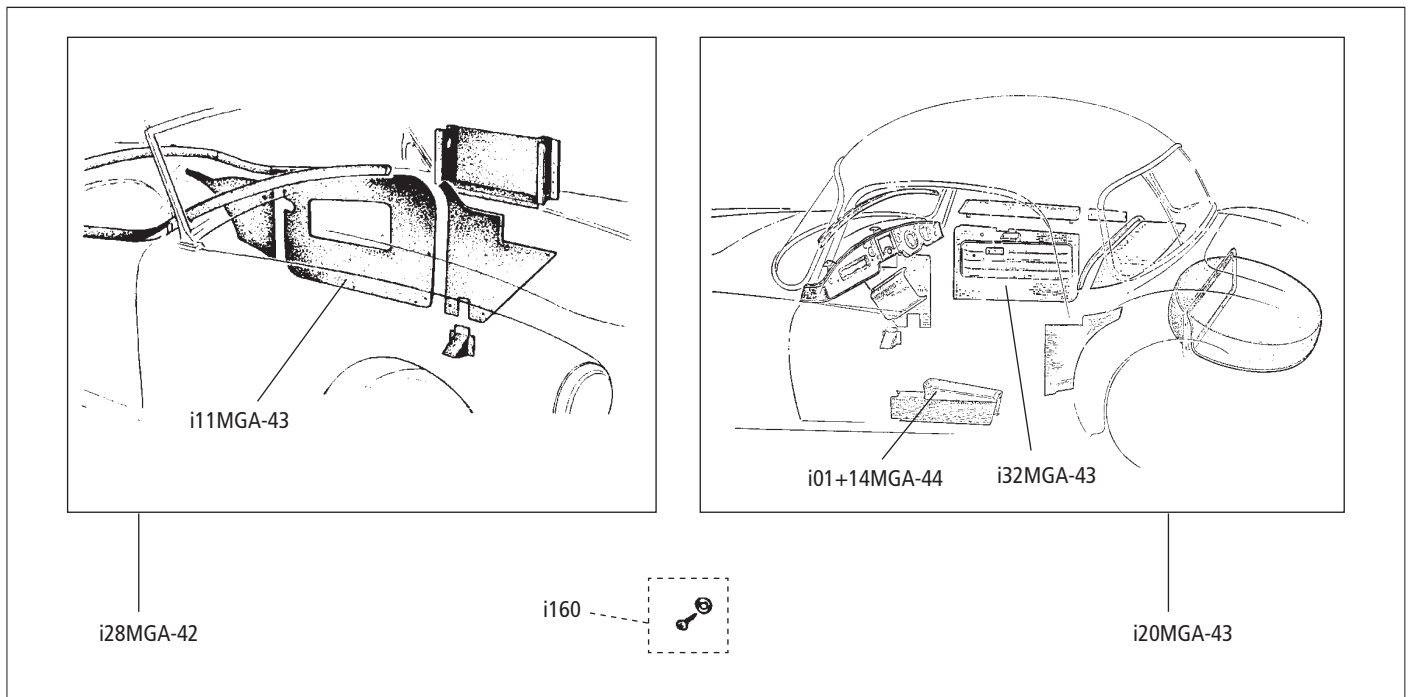

Hinweis 
Note:

Superior-Innenausstattungssatz:
Originalgetreuer, passgenauer und einfach zu montierender Innenausstattungssatz, gefertigt aus hochwertigem Vinylleder; bestehend aus 2 Türbekleidungen mit montierten Türtaschen, 2 Fußraum-Seitenteilen, 2 hinteren Seitenteilen, 2 Rahmenbekleidungen vorne und ausreichend Vinylleder und Kederband zum Bekleiden der umlaufenden Tür- und Cockpit-Leisten, sowie den originalen Befestigungsschrauben und Unterlegscheiben in der benötigten Stückzahl.

Superior trim kit:
Vinyl trim kit, made to original design, incorporating 1 pair door panels including door pockets, 1 pair scuttle panels, one pair rear wheel arch panels, 2 chassis cover panels, 1 packet of 40 screws and cup washers, sufficient material to retrim the door cappings, lower dash crash rail piping, piece of leather-cloth to cover top of dash and dash fascia, one length of 4meter 1/8" dia. Piping, fitting instructions.

No.	Bezeichnung	Description	Anzahl/Qty.
i01MGA-45	Satz Sitzschienen Sitz rechts (4 tlg)	Seat slide set right hand (4 pcs)	1
i02MGA-45	Satz Sitzschienen Sitz links (4 tlg)	Seat slide set left hand (4 pcs)	1
i03MGA-45	Befestigungs-Kit Sitzsch. (beide Sitze) (außer Comp. De Luxe)	Seat slide fitting kit (both seats assembly except comp. DeLuxe)	1
i05MGA-45	Sitzgestell Roadster rechts	Seat frame roadster right hand	1
i06MGA-45	Sitzgestell Roadster links	Seat frame roadster left hand	1
i07MGA-45	Sitzgestell Coupé rechts	Seat frame coupe right hand	1
i08MGA-45	Sitzgestell Coupé links	Seat frame coupe left hand	1
i09MGA-45	Sitzgestell De Luxe rechts	Seat frame de Luxe right hand	1
i10MGA-45	Sitzgestell De Luxe links	Seat frame de Luxe left hand	1
i12MGA-45	Karton Sitzrücken	Seat squab board	2
i13MGA-45	Satz Sitzstrapse De Luxe (4 tlg)	Seat strap kit de Luxe (4 pcs)	1
i110TR	Befestigungsclip Sitzbezug	Clip tubular seat cover/frame	A/R
i113TR	Befestigungsklammer Sitzplatte	Clip spring	A/R
i30MGA-45	Schaumstoff-Sitzlehne rechts	Seat squab foam right hand	1
i31MGA-45	Schaumstoff-Sitzlehne links	Seat squab foam left hand	1
i32MGA-45	Schaumstoff-Sitzfläche Roadster + Coupé	Seat bottom foam roadster and coupe	2
i33MGA-45	Schaumstoff-Sitzfläche links/rechts De Luxe	Seat bottom foam de Luxe	2
i34MGA-45	Schaumstoff-Rückenlehne links/rechts Roadster + Coupé	Seat squab foam roadster and coupe	2
i35MGA-45	Schaumstoff-Rückenlehne links/rechts De Luxe	Seat squab foam de Luxe	2
i36MGA-45	Satz Schaumstoff-Kerne De Luxe (4 tlg)	Seat foam set „de Luxe“ (4 pcs)	1
i39MGA-45	Holz-Sitzunterlage rechts Roadster + Coupé	Wooden seat base right hand	1
i40MGA-45	Holz-Sitzunterlage links Roadster + Coupé	Wooden seat base left hand	1
i76SPT	Beckengurt universal	Seat belt 2-point	2

Ledersitze Roadster

Leather seats Roadster

i01MGA-46	Paar Ledersitze komplett schwarz/weißer Keder	Pair leather seats assembly black/white piping	1
i02MGA-46	Paar Leder-Sitzbezüge schwarz/weißer Keder	Pair leather seat covers black/white piping	1
i03MGA-46	Paar Vinyl-Sitzbezüge schwarz/weißer Keder	Pair vinyl seat covers black/white piping	1

Ledersitze Coupé

Leather seats Coupe

i01MGA-47	Paar Ledersitze komplett schwarz/weißer Keder	Pair leather seats assembly black/white piping	1
i02MGA-47	Paar Leder-Sitzbezüge schwarz/weißer Keder	Pair leather seat covers black/white piping	1
i03MGA-47	Paar Vinyl-Sitzbezüge schwarz/weißer Keder	Pair vinyl seat covers black/white piping	1

Ledersitze Competition De Luxe

Leather seats Competition De Luxe

i01MGA-48	Paar Ledersitze komplett schwarz/weißer Keder	Pair leather seats assembly black/white piping	1
i02MGA-48	Paar Leder-Sitzbezüge schwarz/weißer Keder	Pair leather seat covers black/white piping	1

**Hinweis
Note:**



Anmerkung zu unseren „Paar Sitze komplett“:
Dies sind vollständig neue Sitze, die montagefertig sind;
Sie schrauben diese Sitze nur noch einfach mit vier Schrauben
an den Sitzschienen ihres MGA fest - und das war's!

Note to our „pair seats assembly“: These are complete
newseats. Fitting is straightforward as these bespoke seats
utilise the original seat adjustment sliders. Just unbolt the old
ones and bolt in the new seats!

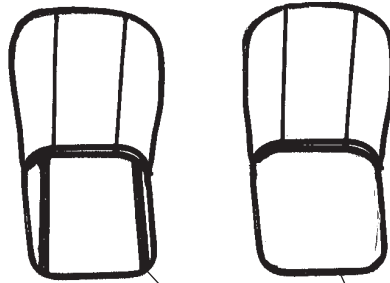
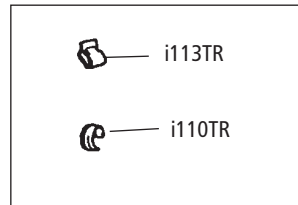
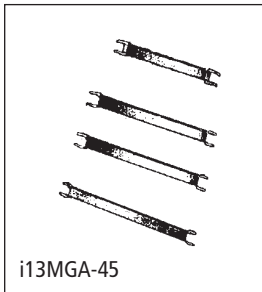
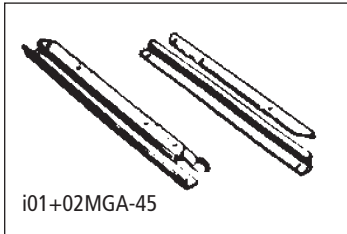
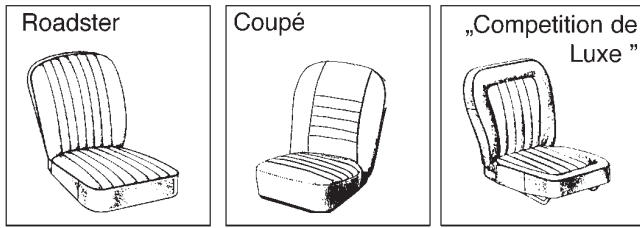

i05-08MGA-45
i09-10MGA-45

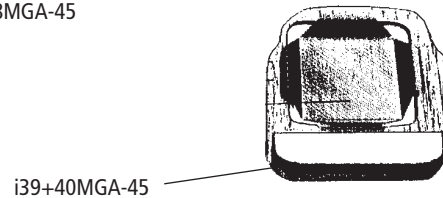
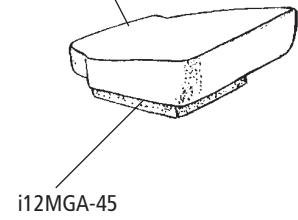
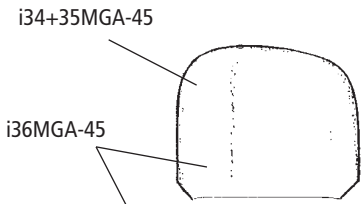
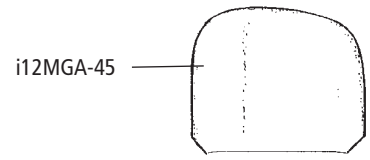

No.	Bezeichnung	Description	Anzahl/Qty.
EM03MGA-02	Emblem -1600- (Kofferraumdeckel + Frontblech)	Badge -1600- (trunk lid + front scuttle)	1
EM04MGA-02	Emblem -1600 MK2- (Kofferraumdeckel + Frontblech)	Badge -1600 MK2- (trunk lid + front scuttle)	1
S05MGA-02	Innenspiegel	Interior mirror	1
S07MGA-02	Befestigungsschraube Innenspiegel	Countersunk screw interior mirror	2
S08MGA-02	Umrandung Defrosterdüse	Demister finisher	2
S8SPTMK3R	Lucas-Style-Spiegel rechts	Lucas-style mirror right hand	1
S8SPTMK3L	Lucas-Style-Spiegel links	Lucas-style mirror left hand	1
S8C	Talbot-Style-Spiegel	Talbot-style-torpedo mirror	2
S09MGA-02	Chrom Schraube Luftauslaß	Chrome screw demister finisher	4
RT12MGA-02	Satz Gummitüllen außer Spritzwand (9 tlg)	Grommet set other than bulkhead (9 pcs)	1
S13MGA-02	Auflagegummi Motorhaube	Buffer bonnet lid	A/R
S15MGA-02	Stopfen Loch Getriebeölmeßstab	Plug hole gearbox dipstick	1
S17MGA-02	Haltering Schalthebelgummi	Gear lever gaiter ring	1
S18MGA-02	Aufstellstange Motorhaube	Bonnet prop rod	1
S19MGA-02	Halteklammer Aufstellstange	Retaining clip bonnet prop rod	1
S20MGA-02	Sicherungsbügel Motorhaube	Safety catch bonnet	1
S21MGA-02	Haltelasche Sicherheitsbügel	Bracket bonnet catch	1
S22MGA-02	Feder Haubenverschluß	Spring bonnet catch	1
S23MGA-02	Auflage Feder Haubenverschluß	Bonnet spring cup	1
S24MGA-02	Zentrierstift Haubenverschluß	Pin bonnet catch	1
S25MGA-02	Führungsplatte Haubenverschluß	Plate guide bonnet catch pin	1
S26MGA-02	Spannungsfeder Haubenhaken	Spring tension bonnet catch	1
S27MGA-02	Satz Kotflügelkeder (für 1 Fahrzeug komplett)(Silber)	Set wing piping (for 1 car)(silver)	1
S28MGA-02	Scharnier Motorhaube rechts	Bonnet hinge right hand	1
S29MGA-02	Scharnier Motorhaube links	Bonnet hinge left hand	1
RT29MGA	Satz Gummistopfen Spritzwand (33 tlg)	Grommet set bulkhead (33 pcs)	1
G30MGA-19	Schalthebelgummi	Gear lever gaiter	1
S30MGA-02	Lüftungsgitter	Vent grille	2
S31MGA-02	Aschenbecher mit Chromdeckel	Ashtray with chrome top	1
F34MGA-36	Radkappe Stahlfelge	Hub cap steel wheel	4
i117	Mutter	Nut	2
S33MGA-02	Satz Gummis* MGA1500 Roadster	Body rubber set* MGA1500 roadster	1
S34MGA-02	Satz Gummis* MGA1500 Coupé	Body rubber set* MGA1500 coupe	1
S35MGA-02	Satz Gummis* MGA1600 Roadster	Body rubber set* MGA1600 roadster	1
S36MGA-02	Satz Gummis* MGA1600 Coupé	Body rubber set* MGA1600 coupe	1
S37MGA-02	Satz Gummis* MGA1600 MK2 Roadster	Body rubber set* MGA1600 MK2 roadster	1
S38MGA-02	Satz Gummis* MGA1600 MK2 Coupé	Body rubber set* MGA1600 MK2 coupe	1

Hinweis
Note:

* Die „Gummi-Sätze“ enthalten alle Gummidichtungen, Stopfen, Tüllen, Auflagegummis usw., die am Fahrzeug vorhanden sind, außer den Chassis-Auflagen!

* Note: Virtually all of the rubber, pads, seals, and such on the car are included in these sets, except chassis/body mounting strips!

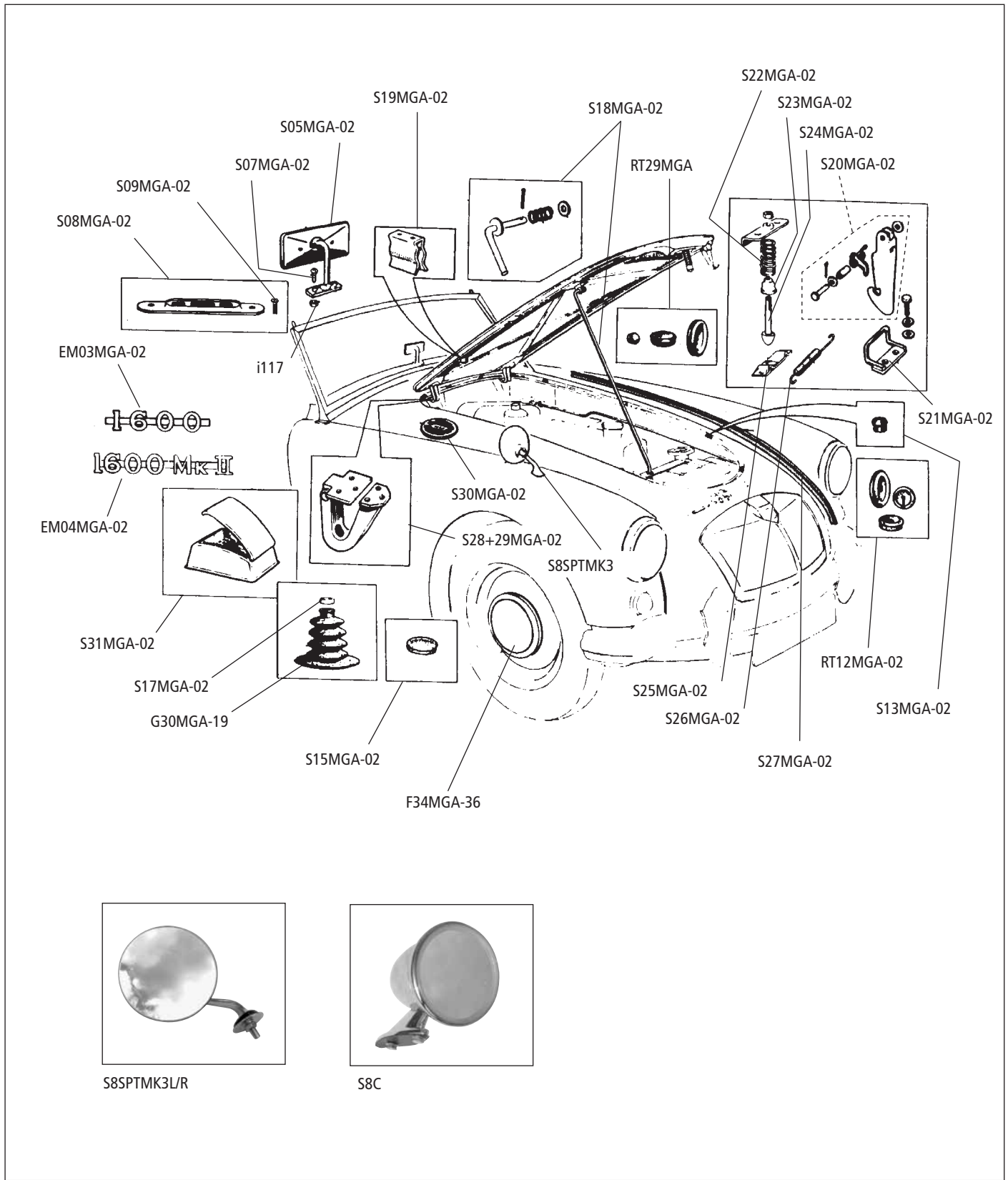

No.	Bezeichnung	Description	Anzahl/Qty.
EM1ATR	Befestigungsklammer	Fixing clip	2
S01MGA-01	Stoßstange vorne (3 tlg)	Front bumper (3 pcs)	1
S02MGA-01	Befestigungs-Satz Stoßstange vorne (59 tlg)	Front bumper bolt kit (59 pcs)	1
S03MGA-01	Stoßstangenhorn	Overrider	2
S06MGA-01	Chrom Stoßstangenschraube + Mutter	Chrome bumper bolt + nut	3
S07MGA-01	Chrom Stoßstangenschraube	Chrome bumper bolt	2
S08MGA-01	Stoßstangenhalter vorne	Front bumper bracket	2
S09MGA-01	Original Badge-Bar (Emblemhalter)	Original badge-bar	1
S10MGA-01	Halter Zusatzlampe rechts	Fog/spot lamp bracket right hand	1
S11MGA-01	Halter Zusatzlampe links	Fog/spot lamp bracket left hand	1
R12MGA-01	Gummidichtung Stoßstangenhalter	Front valance grommet	4
S13MGA-01	Halter Nummernschild vorne rechts	Number plate bracket right hand	1
S14MGA-01	Halter Nummernschild vorne links	Number plate bracket left hand	1
S15MGA-01	Nummernschildblech vorne	Number plate backing front	1
S15AMGA-01	Nummernschildblech vorne Edelstahl	Number plate backing front stainless steel	1
EM29MGA-01	Unterlage Kühlergrillembem	False nose grill	1
EM31MGA-01	Emblem Kühlergrill schwarz	Grille badge black	1
S34MGA-01	Schraube Kühlergrill/Umrandung	Bolt radiator grille/shell	2
S1/4"X1/2"	Schraube Kühlergrill/Karosserie	Setscrew grille/body	6
S36MGA-01	Kederband Kühlergrill (Silber)	Grille piping (silver)	1
S42MGA-01	Kühlergrill komplett 1500/1600	Radiator grille assembly 1500/1600	1
S43MGA-01	Kühlergrill komplett 1600 MK2	Radiator grille assembly 1600 MK2	1
S55SPT	Gummileiste Stoßstangenhorn	Overrider moulding strip	4
i117	Mutter für Schraube Nr. S34MGA-01	Nut UNF for bolt no. S34MGA-01	5

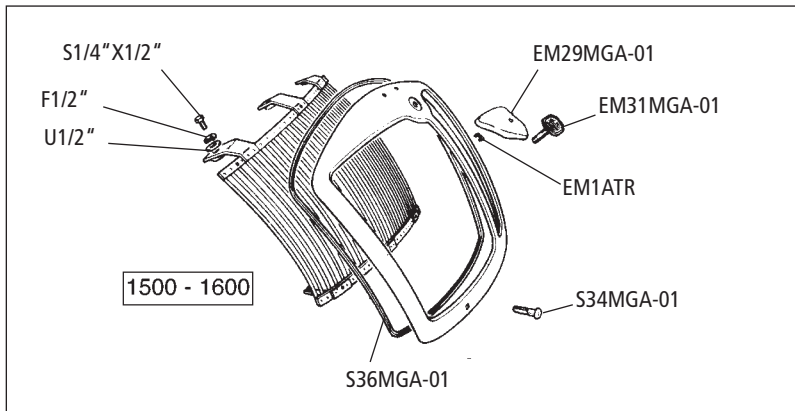
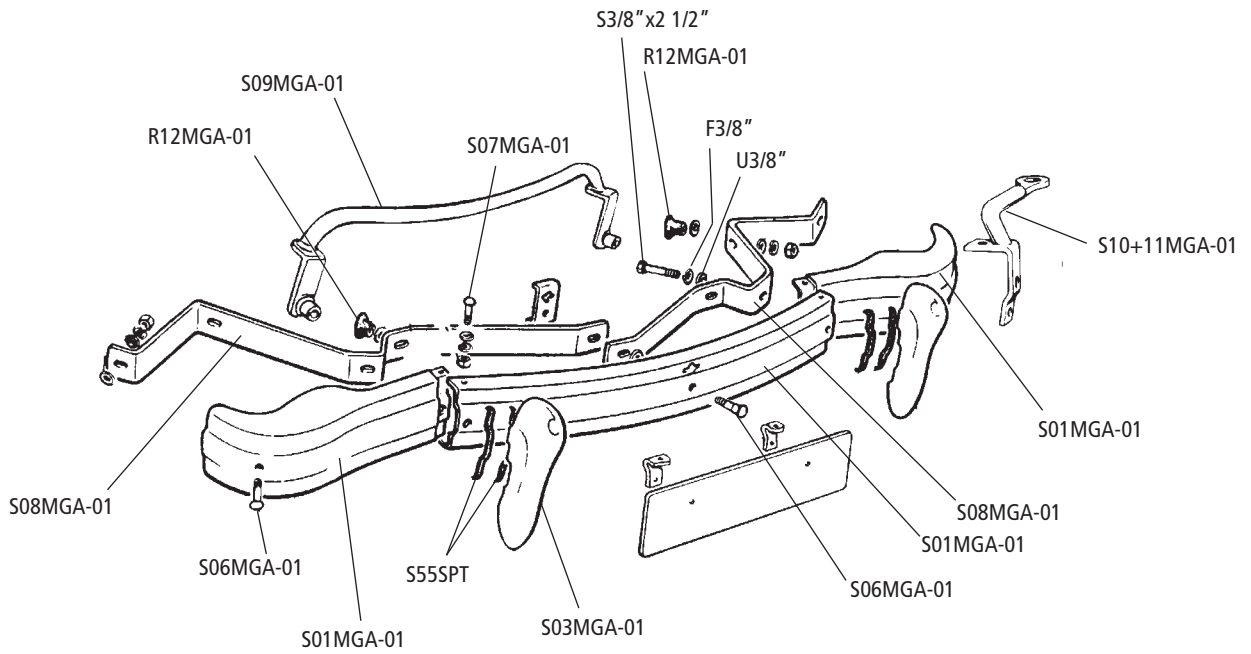

S42MGA-01

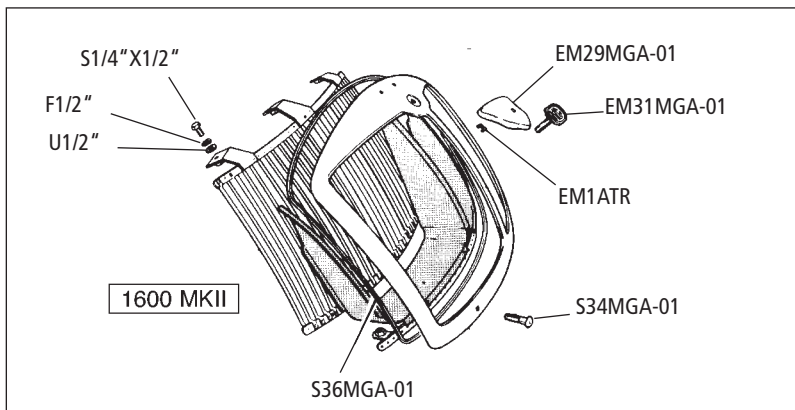
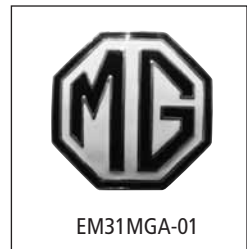

S43MGA-01

No.	Bezeichnung	Description	Anzahl/Qty.
S01MGA-03	Stoßstange hinten	Rear bumper	1
S02MGA-03	Befestigungs-Satz Stoßstange hinten (74 tlg)	Rear bumper fitting kit (74 pcs)	1
S03MGA-01	Stoßstangenhorn	Overrider	2
S06MGA-01	Chrom Stoßstangenschraube + Mutter	Chrome bumper bolt and nut	2
S08MGA-03	Chrom Stoßstangenschraube (Mitte)	Chrome centre rear bumper bolt	2
S09MGA-03	Halter Stoßstange hinten	Rear bumper bracket	2
R12MGA-01	Gummidichtung Stoßstangenhalter hinten	Rear valance grommet	2
S12MGA-03	Halter Nummernschild hinten	Number plate backing rear	1
S13MGA-03	Halter Nummernschild hinten Edelstahl	Number plate backing rear stainless steel	1
S14MGA-03	Platte Halter Nummernschild	Mounting bracket number plate	1
S15MGA-03	Halter Nummernschildleuchte	T-bracket number plate	1
S20MGA-03	Korkdichtung Tankeinfülldeckel	Cork seal petrol cap	1
V20MGA-17	Gummiring Einfüllstutzen/Heckblech	Ferrule filler extension	1
V21MGA-17	Dichtung Einfüllstutzen/Kofferraumboden	Rubber seal filler extension	1
S22MGA-17	Tankeinfülldeckel	Petrol filler cap	1
S23MGA-03	Befestigungsscheibe Einfüllstutzen	Seal plate filler extension	1
S24MGA-03	Reserveradhalter	Spare wheel clamp	1
S25MGA-03	Flügelmutter Reserveradhalter	Wing nut spare wheel clamp	1
i26MGA-39	Chromhalterung Verdeck	Chrome rear hood retainer	2
S26MGA-03	Spannbolzen Reserveradhalter	Eye bolt spare wheel clamp	1
S27MGA-03	Querstift Reserveradspannbolzen	Pivot pin eye bolt spare wheel clamp	1
S27MGA-02	Satz Kotflügelkeder (für 1 Fahrzeug komplett) (Silber)	Set wing piping (for 1 car)(silver)	1
S28MGA-02	Scharnier Kofferraumdeckel rechts	Trunk lid hinge right hand	1
S29MGA-02	Scharnier Kofferraumdeckel links	Trunk lid hinge left hand	1
S35MGA-03	Paar Filzunterlagen Reserverad	Pair felt packing under spare wheel	1
S37MGA-03	Kofferraumgummi	Boot lid seal	1
S51MGA-03	Türanschlaggummi hinterer Türpfosten inkl. Befestigung	Buffer on b-post incl. fittings	4/2
EM40MGA-03	Satz Befestigungsklammer Embleme (24 tlg)	Spire clips set boot lid badge (24 pcs)	1
EM03MGA-02	Emblem -1600- (Kofferraumdeckel + Frontblech)	Badge -1600- (trunk lid + front scuttle)	3
EM04MGA-02	Emblem -1600-MK2- (Kofferraumdeckel + Frontblech)	Badge -1600 MK2- (trunk lid + front scuttle)	3
EM43MGA-03	Emblem -Twin-Cam-	Badge -twin-cam-	3
EM44MGA-03	Emblem MG-Octagon (3 tlg)	Badge MG + octagon surround (3 pcs)	1
EM45MGA-03	Befestigungsklammer MG-Octagon	Clip badge MG + octagon surround	13
S49MGA-03	Unterlegdeckel Chromhalterung Verdeck	Washer cup hood retaining plate	2
S50MGA-03	Halteklammer Handkurbel	Clip handcrank	3
RT54MGA-03	Gummitülle Kofferraumöffnerstange	Ferrule trunk lid release rod	1
S55MGA-03	Führung Kofferraumöffnerstange	Guide trunk lid release rod	1
S55SPT	Gummileiste Stoßstangenhorn	Overrider moulding strip	4
S57MGA-03	Original Gepäckträger Edelstahl	Original luggage rack stainless steel	1
S58MGA-03	Aufstellstange Kofferraumdeckel	Prop rod trunk lid	1
S60MGA-03	Klammer Aufstellstange	Clip prop rod trunk lid	1
S63MGA-03	Verriegelung Kofferraumdeckel	Trunk lid lock	1

Hinweis
Note:



Anmerkung: komplette „Fahrzeug-Gummi-Sätze“
- siehe Seite 92.

Note: „rubber seal kits“ on page 92.

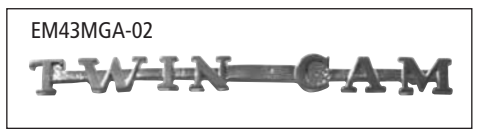
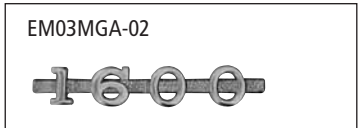
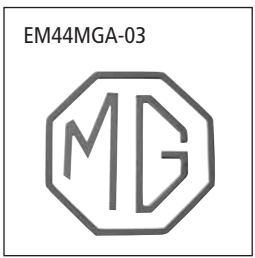
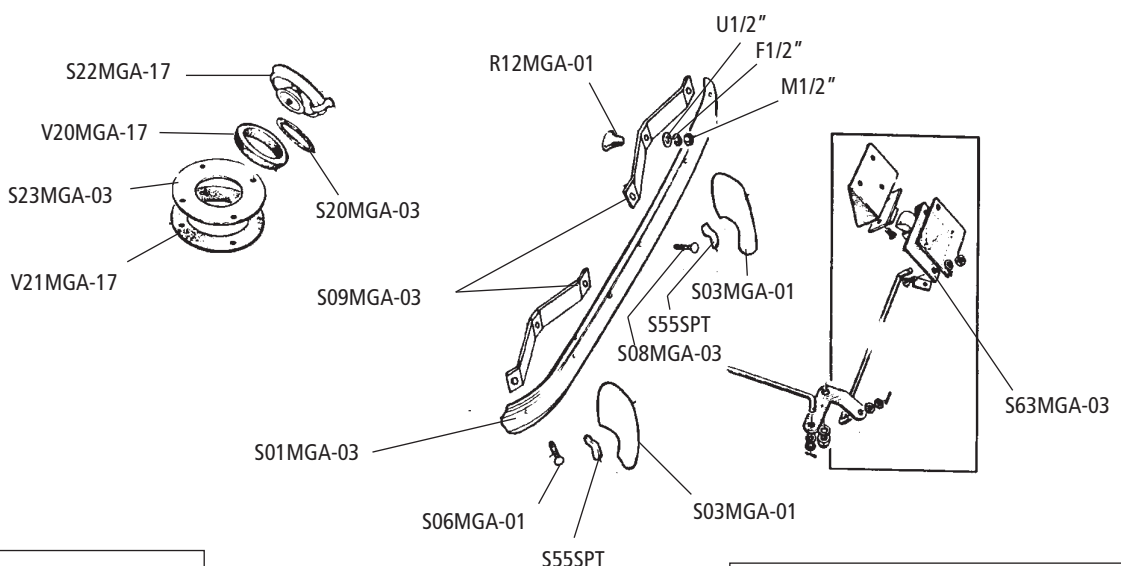
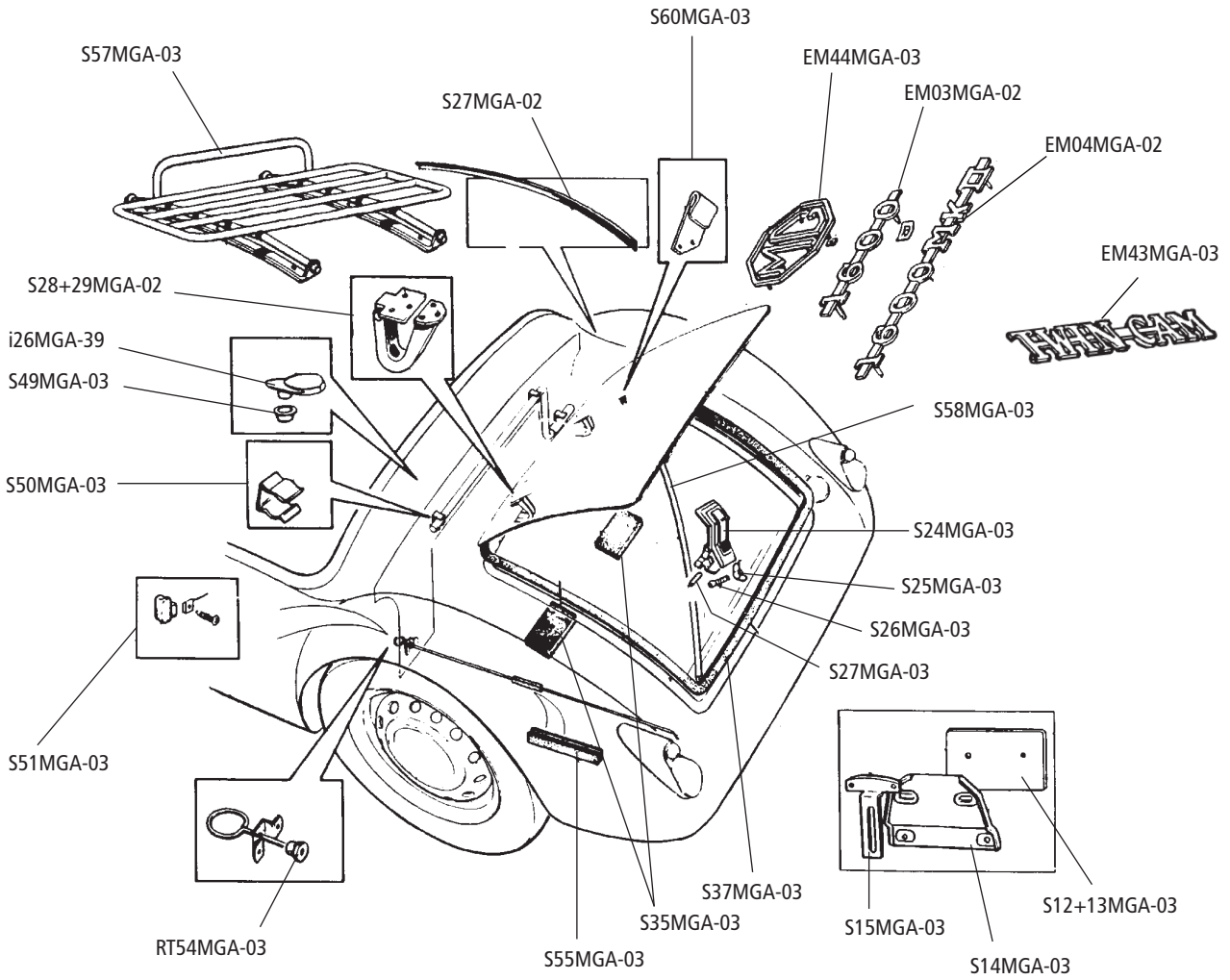

No.	Bezeichnung	Description	Anzahl/Qty.
EM01MGA-50	Satz Aufkleber Coupé	Decal kit coupe	1
EM02MGA-50	Satz Aufkleber Roadster	Decal kit roadster	1
EM03MGA-50	Typenschild 1500 „Früh“	Plate commission no 1500 early	1
EM04MGA-50	Typenschild 1500 „Spät“ + 1600	Plate commission no 1500 late +1600	1
EM05MGA-50	MG-Zeichen Metall	Plate rocker cover „MG“	1
EM06MGA-50	Westlake Patent Metall	Plate valve cover „Westlake patent“	1
EM07MGA-50	Zündfolge-Schild Messing 1500	Plate brass firing order 1500	1
EM08MGA-50	Zündfolge-Schild Messing 1600	Plate brass firing order 1600	1
EM09MGA-50	Aufkleber „Safety Fast“ (Innenseite Frontscheibe)	Sticker „safety fast“ frontscreen (inner)	1
EM10MGA-50	Aufkleber „Safety Fast“ (außen)	Sticker „safety fast“ (body)	1
EM11MGA-50	Aufkleber „Special Tuning“ (außen)	Sticker „special tuning“ (body)	1
EM20MGA-50	Schlüsselanhänger mit -MG-Emblem	Key fob -MG- octagon	A/R
EM22MGA-50	Schlüsselanhänger mit „Union-Jack“-Emblem	Key fob „Union Jack“ flag	A/R
S34MGA-19	Original-Schaltknopf	Original gear lever knob	1
S35MGA-19	Holzschaltknopf mit -MG-Emblem (Vollgummi-Einsatz)	Wooden gear knob -mg- logo (nylon thread insert)	1
S36MGA-19	Lederschaltknopf mit -MG-Emblem (Vollgummi-Einsatz)	Leather gear knob -MG- logo (nylon thread insert)	1
S24MGA-19	Holzschaltknopf mit -MG-Emblem (Metall-Innengewinde)	Wooden gear knob -mg- logo (metal thread insert)	1
EM32SPT	Union Jack-Fahne emailliert, klein (5,9 X 3,5 cm)	Union Jack enamel badge (5,9 x 3,5 cm)	A/R
EM33SPT	Union Jack-Fahne Plastik klein (5,9 X 3,5 cm)	Union Jack self-adhesive (5,9 x 3,5 cm)	A/R
i116AMGA	Paar Schutzmatte mit MG Logo	Overmats with MG-logo, pair	1



S36MGA-19

S35MGA-19,
S24MGA-19

S43MGA-19



EM11MGA-50



i116AMGA



EM20MGA-50



EM32SPT



EM33SPT

No.	Bezeichnung	Description
	Original Bedienungsanleitung (engl.)	Original Owners Handbook (engl.)
Li08MGA-49	MGA1500	MGA1500
Li09MGA-49	MGA1600	MGA1600
Li10MGA-49	MGA1600 MK2	MGA1600 MK2
Li11MGA-49	MGA Twin-Cam	MGA Twin-Cam
Li01MGB-50	MGB Bj. 1962 bis Bj.1965	MGB 1962-65
Li02MGB-50	MGB Bj. 1967 bis Bj.1976 "Europa"	MGB 1967-76 „Europe“
Li03MGB-50	MGB Bj. 1969 bis Bj.1972 "Europa"	MGB 1969-72 „Europe“
Li04MGB-50	MGB nur Bj. 1969 "Europa"	MGB 1969 „Europe“
Li05MGB-50	MGB Bj. 1968 bis Bj.1969 "USA"	MGB US 1968-69
Li07MGB-50	MGB Bj. 1972 "USA"	MGB US 1972
Li08MGB-50	MGB Bj. 1973 "USA"	MGB US 1973
Li09MGB-50	MGB Bj. 1974 "USA"	MGB US 1974
Li10MGB-50	MGB Bj. 1975 bis Bj. 1976 "USA"	MGB US to 1976
Li12MGB-50	MGB Bj. 1978 "USA"	MGB US 1978
Li13MGB-50	MGB Bj. 1979 "USA"	MGB US 1979
	Original Bedienungsanleitung (deutsch.)	Original Owners Handbook (german)
Li50MGA	MGA 1500/1600/1622	MGA 1500/1600/1622
Li54MGB	MGB Bj. 1968-73 Roadster GHN4-GHN5, GT GHD4-GHN5	MGB 1968-73 Roadster GHN4-GHN5, GT GHD4-GHN5
	Original Ersatzteilkatalog (engl.)	Original Parts Book (engl.)
Li01MGA-49	MGA 1500	MGA 1500
Li02MGA-49	MGA 1600	MGA 1600
Li15MGB-50	MGB bis Bj. 9/1976	MGB up to 1976
Li16MGB-50	MGB ab Bj. 9/1976	MGB from 1976
	Original Werkstatthandbuch (engl.)	Original Workshop Manual (engl.)
Li03MGA-49	MGA 1500/1600 (engl.)	MGA 1500/1600 (engl.)
Li05MGA-49	MGA Twin/Cam (engl.)	MGA Twin/Cam (engl.)
Li06MGA-49	MGA/MGB bis 1968 (engl.)	MGA/MGB up to 1968 (engl.)
Li18MGB-50	MGB Bj. 1977 bis Bj.1978 (engl.)	MGB 1977-1978 (engl.)
Li19MGB-50	MGB ab Bj. 1978 (engl.) Taschenbuch-Format	MGB from 1978 (engl.)
Li20MGB-50	MGA/MGB bis Bj.1968 (engl.) Taschenbuch-Format	MGA/MGB up to 1968 (engl.) pocket size
Li21MGB-50	MGB ab Bj.1968 (engl.) Taschenbuch-Format	MGB from 1968 (engl.) pocket size
	Original Werkstatthandbuch (deutsch)	Original Workshop Manual (german)
Li17MGA	MGA (deutsch)	MGA (german)
Li17MGB-50	MGB Bj. 1963 bis Bj.1974 (deutsch)	MGB 1963-1974 (german)
	MGC Literatur	Literature MGC
Li10MGC	Betriebsanleitung englisch	Owners Handbook engl.
Li15MGC	Ersatzteilkatalog "Power Units" (Motor + Getriebe)	Spare part catalogue "Power Units" (Engine, Gearbox)
Li16MGC	Ersatzteilkatalog "Mechanik" (Achse, Bremsen,...)	Spare part catalogue "mechanical" parts (axle, breaks,...)
Li17MGC	Ersatzteilkatalog "Karosserie" (Blechteile, Elektrik, Chromteile...)	Spare part catalogue "Body" parts (Panel, Chrome, Electrical)
Li18MGC	Werkstatthandbuch englisch	Workshop manual engl.

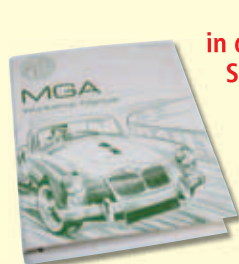

MGA Li17MGA

**in deutscher
Sprache!**

MGB Roadster + GT
Li17MGB-50MGA
Li50MGA





Li54MGB

MGB Roadster + GT

in deutscher Sprache!

No.	Bezeichnung	Description
	Sonstige Literatur (in engl. Sprache)	Other Literature (english)
Li12MGA-49	„MGA special tuning“ Buch (engl.)	Book „MGA special tuning“ (engl.)
Li13MGA-49	SU Carburettors „Haynes“ (engl.)	SU Carburettors „Haynes“ (engl.)
Li14MGA-49	Weber Carburettors „Haynes“ (engl.)	Weber Carburettors „Haynes“ (engl.)
Li15MGA	Weber Carburettor Manual „Haynes TechBook“ (engl.)	Weber Carburettor Manual „Haynes TechBook“ (engl.)
Li40MGB-50	Tuning Handbuch MGB 1962-1967 rot	Tuning Handbook MGB 1962-1967 red
Li41MGB-50	Tuning Handbuch MGB 1968-1980 blau	Tuning Handbook MGB 1968-1980 blue
Li48MGB-50	Workshop Manual MGB Haynes *	Workshop manual MGB Haynes
Li49MGB-50	Workshop Manual MGA Haynes *	Workshop manual MGA Haynes
	(in deutscher Sprache)	(german)
Li13D	SU-Vergaser Praxishandbuch	SU-Carburettors practical guide
Li14D	Weber & Dellorto Querstromvergaser	Weber & Dellorto Carburettors
Li81MGA	„Das Original MGA“ by Clausager, Heel	Original MGA by Clausager, Heel
Li81MGB	„Das Original MGB, MGC, V8“ by Clausager, Heel	Original MGB, MGC, V8 by Clausager, Heel

* Werkstatthandbücher mit detaillierten Beschreibungen, Abbildungen, Tipps und Anweisungen

						
Li01MGA-49	Li01MGB-50	Li02MGA-49	Li02MGB-50	Li03MGA-49	Li08MGA-49	Li10MGA-49
						
Li10MGB-50	Li10MGC	Li11MGA-49	Li12MGA-49	Li13D	Li13MGA-49	Li14D
						
Li14MGA-49	Li15MGA	Li15MGC	Li16MGC	Li17MGC	Li17MGB-50	Li18MGC
						
Li20MGB-50	Li21MGB-50	Li41MGB-50	Li54MGB	Li81MGA	Li81MGB	

Steckschlüssel (Nüsse) - 1/2" Antrieb / Socket wrench inserts 1/2" drive

No.	Größe / Dimension	No.	Größe / Dimension
WZ5	7/16"	WZ13	25/32"
WZ6	1/2"	WZ14	13/16"
WZ7	9/16"	WZ15	7/8"
WZ8	19/32"	WZ16	15/16"
WZ9	5/8"	WZ17	31/32"
WZ10	21/32"	WZ18	1"
WZ11	11/16"	WZ18a	1 1/8"
WZ12	3/4"		

Ring/Gabelschlüssel / Ring- / flat wrenches

No.	Größe / Dimension	No.	Größe / Dimension
WZ19	7/16"	WZ24	3/4"
WZ20	1/2"	WZ25	13/16"
WZ21	9/16"	WZ26	7/8"
WZ22	5/8"	WZ27	15/16"
WZ23	11/16"	WZ28	1"

No.	Bezeichnung	Description
WZ2	Steckschlüssel-Satz 12-tlg.	Socket wrench 12-pieces
WZ3	Ring/Gabelschlüssel-Satz, 9-tlg (Schlüssel 3/8" bis 3/4")	Ring- / flat wrench set, 9 pcs. (dimension 3/8" to 3/4")
WZ4	Inbusschlüssel-Satz	Hexagon wrench set
WZ40	Inbusschlüssel 3/16"	Hexagon wrench set 3/16"
WZ04MGA-53	Zoll-Fühlerlehre (0.0015" - 0.0025")	Feeler gauge (0.0015" - 0.0025")
WZ16MGA-53	Einstellschlüssel SU-Vergaser	Adjusting tool SU-carburettor
WZ19MGA-53	Fettpresse, klein	Grease gum, small
WZ50/UNC	Hochwertiger Gewindegewinde- schneider Satz 1/8" - 1/2" im Holzkoffer: für Grobgewinde UNC	Taps & Dies set 1/8" - 1/2" high quality tool in wooden box: for UNC
WZ50/UNF	für Feingewinde UNF	for UNF
WZ55	Magnetische Schale	Magnetic tray
WZ101	Einstellschlüssel für Einstell- exzenter Bremse, Schlüssel- weite 1/4" + 5/16"	Tool for wheel cylinder adjuster, dimension 1/4" + 5/16"

No.	Bezeichnung	Description
MD17SPT	Dauerplast. Universaldich- tung „Marston“ 80 ml	Universal jointing compound „Marston“ 80 ml
MD17ASPT	Hochwertige Silikondicht- masse - schwarz „Hylasil“ 200 ml	Silicone sealant - black „Hylasil“ 200 ml
MD20/HF	Schrauben Sicherung „hochfest“ 50 ml Flasche	„Stud lock“ - 50 ml high strenght
MD20/MF	Schrauben Sicherung „mittelfest“ 50 ml Flasche	„Stud lock“ - 50 ml medium strenght
MD21/HF	Buchsen-und Lagerbe- festigung 50 ml Flasche „hochfest“	„Bush & Bearing lock“ 50 ml high strenght

Wir vertreiben ausschließlich hochwertige Qualitätswerkzeug von führenden Herstellern (FACOM, HAZET, Stahlwille usw.) mit lebenslanger Garantie bei sachgemäßer Handhabung.

We sell only high-quality tools made by the leading manufacturers (FACOM, HAZET, Stahlwille etc...) with lifetime warranty if properly used.



RAVENOL®



RV3010-5

RV3010-1



RV3004



RV3002



RV3059



RV3057



RV3025



RV3009

RV3030

RV3031

RV3033

RV3034



RV2004



RV4608 7

RV4608 3



RV3005



RV46170



RV4605 3

RAVENOL Pumpflaschen / RAVENOL pump aerosol 500 ml

No.	Bezeichnung	Description
RV3002	Kaltreiniger (lösemittelfrei) zur hochwirksamen Reinigung von Motor- und Maschinenteilen, lackierten und Kunststoffteilen, Fliesen uvm.	Cleaner of all kind of engines, mechanical parts. It quickly penetrates grease, dirt, oil and grime, and swiftly removes contaminants. Product w/o solvent
RV3004	Teerentferner bei Teer- und Ölverschmutzungen auf Chrom und Lack	Cleaner of tar and fats from car lacquers and chrome
RV3025	Glasklar - ideal für alle Glas- und Spiegelflächen innen und außen	Cleaner for all kinds of car glass, mirrors and other hard, glossy surfaces
RV3057	Felgen-Reiniger zur Reinigung von Stahlfelgen, Rahmen, Motor-teilen uvm.	Cleaner of steel wheels, car chassis, engine parts ..
RV3059	Insektenentferner auf Glas-, Lack-, Chrom- und Kunststoffflächen	Cleaner of dirt, insects and bird droppings from car lacquer, polish chrome and metall surfaces

RAVENOL Spraydosen / RAVENOL aerosol can 400 ml

RV3009	Rostlöser mit MoS ₂ , bei festgefressenen Schrauben, Quietsch- und Knarrgeräuschen	Effective remedy for rusted and corroded parts and threads, eliminating squeaks, contains MoS ₂
RV3030	Bremsenreiniger für Bremsen- und Kupplungsteile	Brake cleaner for brake and clutch parts
RV3031	Cockpit-Spray zur Reinigung und Pflege von Kunststoff, Kunst- und Naturleder	Cockpit panel cleaner, restores, penetrates and protects all plastic, vinyl and plexiglas surfaces
RV3033	Silikon Spray für die Gummi- und Kunststoffpflege	Silikon spray lubricant. Used for plastics and rubber.
RV3034	Motorstarter für alle Benzin- und Dieselmotoren geeignet	Motor Starter. For petrol and Diesel engines.

Diverses / Divers

RV3005	Autoshampoo - reinigungsintensiv, umweltschonend, 1 Liter	Universal concentrated liquid detergent excellent for thoroughly cleaning cars, 1 liter
RV3010-1	Destilliertes Wasser - entionisiert für Fahrzeugbatterien, Dampf-bügeleisen, Aquarien, 1 Liter	Special water for antifreeze, dilution and use in accumulators, 1 liter
RV3010-5	Destilliertes Wasser, 5 Liter	Special water (like above) 5 liters
RV4605 3	Messkanne, 1 Liter	Pot, 1 liter
RV4608 3	Trichter Ø 100 mm	Funnel Ø 100 mm
RV4608 7	Trichter Ø 250 mm	Funnel Ø 250 mm
RV4617 0	Mehrzweckwanne, 7 Liter	Pot, universal, 7 liters
RV2004	Super EP-Langzeitfett, für Gleit- und Wälzlager, 400 gr. Patrone	Super EP Long-life grease for all plain and rolling bearings subjected to heavy loads, cartridge 400 g.

Umrechnungstabelle / Conversion Table

Zoll / Inch	1/4"	5/16"	3/8"	7/16"	1/2"	9/16"	5/8"	3/4"	7/8"	1"
Milli- meter	6,35	7,94	9,53	11,12	12,70	14,29	15,88	19,05	22,23	25,40

Zuordnungsübersicht

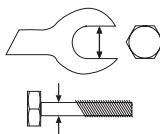

Schlüsselweite (Kopf- größe) / Dimension ▽ = Schaft-Ø / Shaft Ø	7/16"	1/2"	9/16"	5/8"	3/4"
	1/4"	5/16"	3/8"	7/16"	1/2"

Muttern und Unterlegscheiben / Nuts & washers

Innen-Ø / Inner diameter	Mutter / Nut UNF, UNC	1/2 Mutter / 1/2 nut UNF	Selbstsichernde Mutter / Stop nut UNF	Unterlegscheibe / Washer plain	Zahnscheibe / Washer star	Federring / Washer spring	Karoseriescheibe / Washer reinforcing
3/16"	Art.-Nr. / Part No : M3/16"		M3/16"S	U3/16"	Z3/16"	F3/16"	K3/16"
1/4"	Art.-Nr. / Part No : M1/4"	HM1/4"S	M1/4"S	U1/4"	Z1/4"	F1/4"	K1/4"
5/16"	Art.-Nr. / Part No : M5/16"	HM5/16"S	M5/16"S	U5/16"	Z5/16"	F5/16"	K5/16"
3/8"	Art.-Nr. / Part No : M3/8"	HM3/8"S	M3/8"S	U3/8"	Z3/8"	F3/8"	K3/8"
7/16"	Art.-Nr. / Part No : M7/16"	HM7/16"S	M7/16"S	U7/16"	Z7/16"	F7/16"	
1/2"	Art.-Nr. / Part No : M1/2"	HM1/2"S	M1/2"S	U1/2"	Z1/2"	F1/2"	
9/16"	Art.-Nr. / Part No : M9/16"	HM9/16"S	M9/16"S	U9/16"		F9/16"	
5/8"	Art.-Nr. / Part No : M5/8"	HM5/8"S	M5/8"S	U5/8"		F5/8"	

Schrauben / Bolts

Schaft-Ø / Shaft diam.:	Länge / Length:							
	1/2"	3/4"	1"	1 1/4"	1 1/2"	1 3/4"	2"	2 1/4"
3/16"	Art.-Nr. / Part No : S3/16"x1/2"	S3/16"x3/4"	S3/16"x1"	S3/16"x1 1/4"	S3/16"x1 1/2"			
1/4"	Art.-Nr. / Part No : S1/4"x1/2"	S1/4"x3/4"	S1/4"x1"	S1/4"x1 1/4"	S1/4"x1 1/2"	S1/4"x1 3/4"	S1/4"x2"	
5/16"	Art.-Nr. / Part No : S5/16"x1/2"	S5/16"x3/4"	S5/16"x1"	S5/16"x1 1/4"	S5/16"x1 1/2"	S5/16"x1 3/4"	S5/16"x2"	S5/16"x2 1/4"
3/8"	Art.-Nr. / Part No : S3/8"x1/2"	S3/8"x3/4"	S3/8"x1"	S3/8"x1 1/4"	S3/8"x1 1/2"	S3/8"x1 3/4"	S3/8"x2"	S3/8"x2 1/4"
7/16"	Art.-Nr. / Part No :		S7/16"x1"	S7/16"x1 1/4"	S7/16"x1 1/2"	S7/16"x1 3/4"	S7/16"x2"	S7/16"x2 1/4"
1/2"	Art.-Nr. / Part No :				S1/2"x1 1/2"	S1/2"x1 3/4"	S1/2"x2"	S1/2"x2 1/4"
Schaft-Ø / Shaft diam.:	2 1/2"	2 3/4"	3"	3 1/4"	3 1/2"	4"	4 1/4"	4 1/2"
1/4"	Art.-Nr. / Part No : S1/4"x2 1/2"							
5/16"	Art.-Nr. / Part No : S5/16"x2 1/2"	S5/16"x2 3/4"	S5/16"x3"	S5/16"x3 1/4"	S5/16"x3 1/2"			
3/8"	Art.-Nr. / Part No : S3/8"x2 1/2"	S3/8"x2 3/4"	S3/8"x3"	S3/8"x3 1/4"	S3/8"x3 1/2"			
7/16"	Art.-Nr. / Part No : S7/16"x2 1/2"	S7/16"x2 3/4"	S7/16"x3"	S7/16"x3 1/4"	S7/16"x3 1/2"	S7/16"x4"		
1/2"	Art.-Nr. / Part No : S1/2"x2 1/2"	S1/2"x2 3/4"		S1/2"x3 1/4"		S1/2"x4"		
9/16"	Art.-Nr. / Part No :						S9/16"x4 1/4"	S9/16"x4 1/2"

Sonstiges / Divers

No.	Bezeichnung	Description	Anzahl/Qty.
SR1	Sechskant-Blechschaube 6,5 x 20 mm	Hexagon palte screw 6,5 x 20 mm	A/R
SR2	Blechmutter für SR1 - 6,5 mm	Plate nut for SR1	A/R
SR3	Rundkopf-Blechschaube 6,3 x 22	Binding screw 6,3 x 22	A/R
SR4	Rundkopfschraube 1/4"x1" UNF	Binding screw 1/4"x1" UNF	A/R
SR7	Senkkopfschraube 1/4"x1/2" UNF	Countersunk screw 1/4"x1/2" UNF	A/R
SR7-3/4"	Senkkopfschraube 1/4"x3/4" UNF	Countersunk screw 1/4"x3/4" UNF	A/R
SR7-1 3/4"	Senkkopfschraube 1/4"x1 3/4" UNF	Countersunk screw 1/4"x1 3/4" UNF	A/R
SR7-1"	Senkkopfschraube 1/4"x1" UNF	Countersunk screw 1/4"x1" UNF	A/R
SR9	Senkkopfschraube 5/16"x1" UNF	Countersunk screw 5/16"x1" UNF	A/R
SR10	Inbussschraube 1/4"x3/4" UNF	Inbus screw 1/4"x3/4" UNF	A/R
SR11	Sechskant-Blechschaube 5,5 x 15 mm	Hexagon palte screw 5,5 x 15 mm	A/R
SR12	Blechmutter 5,5 mm für SR11	Plate nut 5,5 mm for SR11	A/R
SR13	Senkkopfschraube 3/16"x3/4"	Countersunk screw 3/16"x3/4"	A/R
SR14	Linsenkopfschraube 3/16"x3/4"	Mushroom headed screw 3/16"x3/4"	A/R
SR50	Splint 1,5 mm	Split pin 1,5 mm	A/R
SR51	Splint 2,5 mm	Split pin 2,5 mm	A/R
SR52	Splint 3,2 mm	Split pin 3,2 mm	A/R
SR60	Kupferdichtring - 1/4" Innendurchmesser	Copper washer - 1/4" inner diameter	A/R
SR61	Kupferdichtring - 5/16" Innendurchmesser	Copper washer - 5/16" inner diameter	A/R
SR62	Kupferdichtring - 3/8" Innendurchmesser	Copper washer - 3/8" inner diameter	A/R
SR64	Kupferdichtring - 1/2" Innendurchmesser	Copper washer - 1/2" inner diameter	A/R
S500UNF	Satz UNF Schrauben/Scheiben/Muttern, 500-teilig	Ensemble 500 pieces bolts/washers/nuts UNF	A/R

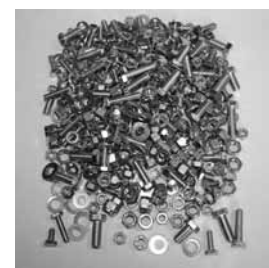

S500UNF

Erkennungsmerkmale des MGA / Identifying the MGA

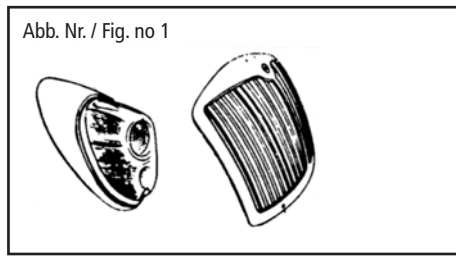

Die drei Hauptmodelle des MGA können leicht äußerlich voneinander unterschieden werden:

Abb. 1 zeigt die Bauweise des Rücklichts, wie es typisch für britische Fahrzeuge dieser Zeit war, sowie den Kühlergrill des 1500 er Modells.

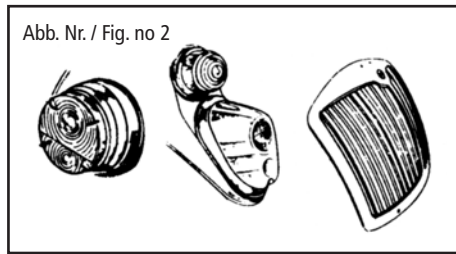

Der 1600 er kann anhand der Doppel-Rückleuchte mit separatem Blinker und den größeren, runden Parkleuchten mit

flachen Glas erkannt werden. Der Frontgrill ist identisch mit dem der 1500 er Modelle geblieben (Abb. 2).

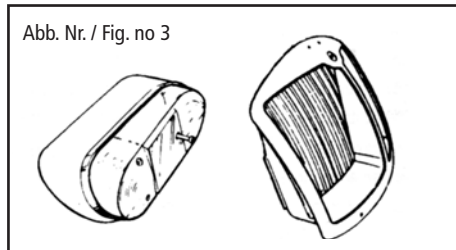

Das markanteste Facelift erhielt das 1600 MK2 Modell. Ein überarbeiteter Frontgrill mit zurückgesetzten Streben löste den flachen Grill

der Vorgängermodelle ab und es wurden Rückleuchten (vom Mini MK1) verbaut, die horizontal angeordnet wurden. (Abb. 3)

The three major MGA models may be readily identified by their tail lamp and grille configurations.

The 1500 style tail-lamps were common to many British cars of the period. The 1500 style grille has slats that are set flush with the back of the shell. (Fig. 1)

A 1600 is differentiated by the dual rear lamp with separate turn lamps and larger round parking lamps with flat lenses. The front grille on 1600 is identical to the 1500 grille. (Fig. 2)

The 1600 MK2 received the closest thing to a face lift an MGA ever got. The famous flat grille was replaced with the "pre-crushed" version. The MK1 Mini rear lamps appeared horizontally below the boot lid. (Fig. 3)

MGA Seriennummern / Serial numbers

Die Motornummer findet sich eingeschlagen auf einem Schild auf der rechten Seite des Zylinderkopfes ... / The engine number is stamped on a plate secured to the right hand side of the cylinder block ...

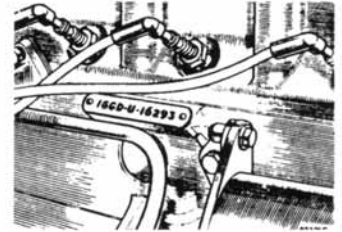

.. oder auf einem Schild an der Motorrückseite hinter dem Zylinderkopf (Twin Cam) / ..or it is stamped on a plate secured to the rear of engine behind the cylinder block (Twin Cam)

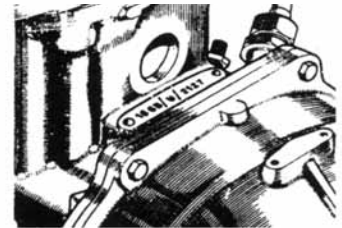

Die Fahrgestellnummern-Plakette befindet sich auf dem waagerechten Blech oberhalb der Motorspritzwand / The car number is stamped on a plate secured to the top left hand side of the dash panel

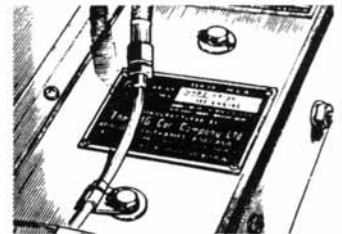

Die Karosserienummern-Plakette findet sich an der Motorspritzwand zwischen dem rechten Motorhaubenscharnier und dem Sicherungskasten / The body number is stamped on a plate secured to the bulkhead between the right hand bonnet hinge and the fuse block

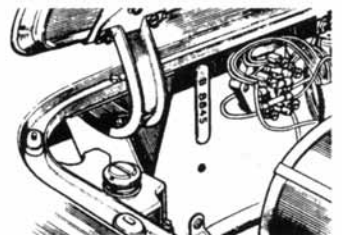

Die Getriebenummer ist am Getriebegehäuse neben dem Ölmeßstab eingeschlagen / The gearbox number is stamped on the top of the gearbox casing adjacent to the dipstick

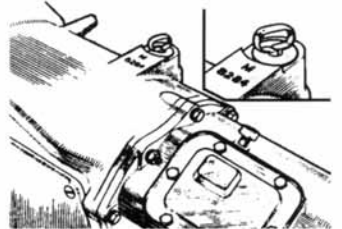

Die Hinterachs-Nummer ist an der linken Vorderseite des Achsrohrs in der Nähe der Blattfeder-Platte eingeschlagen / The rear axle number is stamped on the front of the axle tube on the LH side next to the spring seat

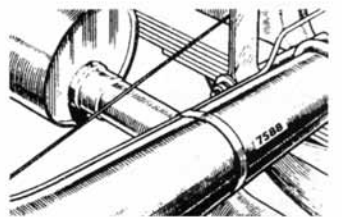

MGA Produktionsdaten / MGA Production data

Fahrzeug-Modell / Model	Produktionszeit / Production period	Stückzahl / No. manufactured (Chassis No.)
MGA 1500	Sept. 1955 - Mai/May 1959	10101 - 68850
MGA Twin CAM	Sept. 1958 - Juni/June 1960	501 - 2611
MGA 1600	Mai/May 1959 - April 1961	68851 - 100351
MGA 1600 MK2	April 1961 - Juni/June 1962	100352 - 109070

MGA Seriennummern / MGA Serial numbers

Die MGA Motornummern können anhand folgender Tafel identifiziert werden. Merke: bei frühen 1500er Motoren wurde der Nummer das Präfix BP vorangestellt

Beispiel: 15 GB / U / H 12345

To identify MGA engines from their serial numbers, the following table should be used. Note the early 1500 engines had the serial numbers prefixed by BP.

Example: 15 GB / U / H 12345

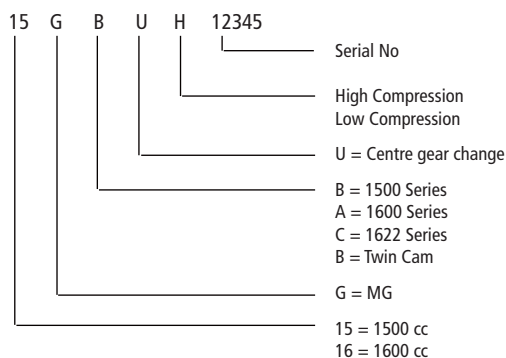

MGA Fahrgestellnummern / MGA Chassis numbers

Die Ziffernreihenfolge der Fahrgestellnummer beinhaltet eine Reihe an Informationen über den Wagen (ob Roadster, Coupé, LHD, RHD...) wie nachstehende Tafeln zeigen:

The letters of the chassis no. is loaded with informations about the car (if it is a Roadster, Coupe, LHD, RHD,..) shown in the following tables:

MGA 1500						
Beispiel / Example	H	D	A	1	2	10101
	Marke / Make	Modell / Model	Lackierung / Colour	Verkaufsmarkt / Market	Lackart / Paint Type	Fzg. Nr / Car No.
	H MGA	D Tourer M Coupe	A Black D Mineral Blue E Island Green H CKD Finish K Orient Red L Glacier Blue R Old Engl. White T Ash Green U Tyrolite Green	1 RHD Home 2 RHD Export 3 LHD 4 North America 5 CDK RHD* 6 CDK LHD*	1 Synthetic 2 Synthetic 3 Cellulose 4 Metallic 5 Primed 6 Cellulose Body & Synthetic Wings	
MGA 1600, 1600 MK2						
Beispiel / Example	G	H	D	L	2	103779
	Marke / Make	Modell / Model	Lackierung / Colour	Verkaufsmarkt / Market	Lackart / Paint Type	Fzg. Nr / Car No.
	G MGA	H 1400cc - 1900cc	N Tourer D Coupe	Blank RHD L LHD	Blank 1600 2 1600MK2	

* CDK Export als Teilesatz

106 Technische Informationen / Technical Data

Wichtige Anzugsdrehmomente / Important torque wrench settings

Radmuttern (Stahlfelge) / Road wheel (Steel wheel)	8,3 - 8,65 mkg
Zylinderkopf / Cylinder head	6,91 mkg
Pleuellagerdeckel / Rod bearing	4,83 mkg
Hauptlagerdeckel / Main bearing	9,7 mkg
Schwungrad an Kurbelwelle / Flywheel crankshaft	5,8 - 6,3 mkg

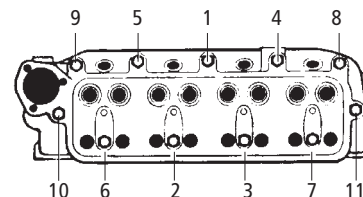

Anziehfolge Zylinderkopfschrauben / Sequence for head bolts

Einstelldaten Motor / Motor data

Fahrzeug-Modell / Model	1500	1600	1600 MK2	Twin Cam
Unterbrecherabstand / Contact breaker gap	0,4 mm	0,4 mm	0,4 mm	0,4 mm
Zündzeitpunkt (statisch) / Static ignition timing	7 ° v.o.T. / BTDC	7 ° v.o.T. / BTDC	(bis / to 4004) -> 10 ° (dann / then) -> 5° *)	9.9:1 -> o.T. (TDC) **) 8.3:1 -> 8° v.o.T (BTDC)
Zündfolge / Engine firing order	1-3-4-2	1-3-4-2	1-3-4-2	1-3-4-2
Zündkerze Elektrodenabstand / Spark plug gap	0,6 mm	0,6 mm	0,6 mm	0,6 mm
Leerlaufdrehzahl / Idle speed	900 - 1100 rpm	900 - 1100 rpm	900 - 1100 rpm	900 - 1100 rpm
Ventilspiel (warm) / Valve rocker clearance (hot)	0,45 mm	0,4 mm	0,4 mm	n.a.

*) 10° v.o.T. bis Motor Nr. 4004, danach 5° v.o.T. / 10 deg. BTDC to engine no 4004, then 5 deg. BTDC
**) ab MotorNr. 2251 Verdichtungsverhältnis 8,3:1 / from engine no. 2251 hub 8.3:1

Schmierung & Füllmengen / Lubrification & Capacities

Fahrzeug-Modell / Model	1500	1600	1600 MK2	Twin Cam	empfohlenes Öl / recommend. oil
Kühlsystem / Cooling system	5,6 l	5,6 l	5,6 l	7,6 l	
Motor / Oil sump	4,2 l	4,2 l	4,2 l	6,75 l	SAE 20W50
Getriebe (nicht OD) / Gearbox (non-OD)	2,2 l	2,2 l	2,6 l	2,25l	Hypoid 80W90
Vergaser / Carburettor ***)	SU H4	SU H4	SU H4	SU H6	Motoröl / Motor oil

***) Zylinder des Dämpferkolbens bis zum Rand füllen / Fill cylinder to edge of damper piston