

DISSEMINATED

AUSTIN-HEALEY

100/4 – 3000 MKIII (BN1 – BJ8)

FAHRZEUGTEILE & ZUBEHÖR · SPARE PARTS & ACCESSORIES



► **Bitte bei allen Bestellungen Kunden- und Artikel-Nummer angeben !**

PS: Die Preise für unsere Produkte finden Sie in der separaten Preisliste ganz leicht mit Hilfe der Artikelnummer. Bestellen können Sie per Telefon oder Fax, per Post oder ganz bequem per eMail.

Hilfreiche Hinweise für eine schnelle Bearbeitung Ihrer Bestellung finden Sie ebenfalls in der Preisliste.

► **Note: when ordering please ensure article and client number !**

PS : A few advices for your order: The pricing for our products are listed in the seperate price list. Here you can get the pricing with the reference number easily. You can order per Post, Telephone, Telefax or very comfortable via E-Mail. Shipment will be made on the cheapest way without extra charge for packing. You will be charged only the delivery costs. Find more details to shipment and handling in the seperate price list.

Hinweise / Notes



Fahrtrichtung /
Sense of direction

- Linke oder rechte (Fahrzeug) Seite
= in Fahrtrichtung gesehen

Left or right side (of the car)
= in sense of direction

- AT-Teile = Austauschteile
Exch.. = parts for exchange

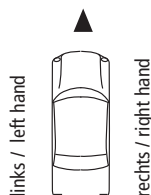

- Anzahl/Qty. = benötigte Anzahl / quantity required
A/R = Anzahl auf Anfrage / quantity at request
1/1 = Bsp.: 1 Artikel pro Seite / 1 piece per side

- **ACHTUNG:** Elektroteile und Literatur sind vom Umtausch ausgeschlossen!
ATTENTION: electrical parts and litterature are not returnable !

		Seite / Page
Motorteile / Zylinderkopf / Ansaugbrücke (Auspuffkrümmer)	Engine / Cylinder Head / Manifold	4
Austausch-, Altteile	Exchange Parts	23
Rennsport & Motortuning	Racing & Motor Tuning	28
Edelstahl Auspuffanlagen	Stainless Exhaust Systems	34
Vergaser	Carburettor	38
Benzintank / Benzinleitungen	Fuel Tank, Lines	52
Gas- und Chokezug	Accelerator & Choke Control	56
Heizung	Heater	63
Kühlanlage	Cooling System	66
Kupplung	Clutch	70
Getriebe	Gearbox	74
Overdrive	Overdrive	82
Hinterachse / Federung	Rear Suspension	84
Hinterachse / Differential	Rear Axle / Differential	88
Vorderachse	Front Suspension	94
Lenkung	Steering	99
Lenkräder	Steering Wheels	106
Felgen / Accessoires	Rims / Accessories	108
Bremsanlage	Brake System	110
Elektrik Lenksäule	Electrical Steering Wheel Column	123
Zündung / Verteiler	Ignition / Distributor	124
Kabelbaum / Batterie	Wiring Loom / Battery	128
Anlasser / Lichtmaschine	Starter Motor / Generator	130
Elektrik, diverses	Miscellaneous Electrical	132
Zusatzinstrumente	Instruments	133
Beleuchtung	Lights	134
Scheibenwaschanlage	Wiper & Washer System	138
Frontscheibe	Windshield	140
Rahmen	Chassis	144
Karosserieteile	Body Panels	148
Tür / Türbefestigung	Doors & Fittings	160
Verdeck / Verdeckabdeckung	Hood / Tonneau Cover	168
Armaturenbrett	Dashboard	174
Chromteile / Schließzylinder	Chrome Parts, Front & Rear Body Fittings	182
Chromteile / Stoßstangen	Chrome Parts, Bumper	194
Innenausstattung	Interior Trim	198
Teppichsätze	Interior Trim, Carpet Sets	216
Team BASTUCK Collection	Team BASTUCK Collection	219
Accessoires & Retro Radio	Accessories & Retro Radio	220
Literatur	Literature	222
Werkzeug u. Hilfsmittel	Tools and externals	224
Pflege- und Schmiermittel	Care Products / Lubricants	225
Zollschrauben / -muttern	Screws / Nuts	226
Fahrzeugidentifikation	Car Specification	228
Technische Informationen	Technical Data	230
Verkaufs- u. Lieferbedingungen	Terms & Conditions	231

Motor / Internal Engine BN1-BN2

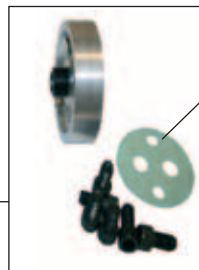
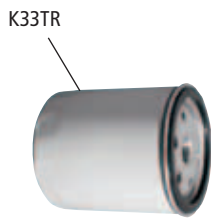
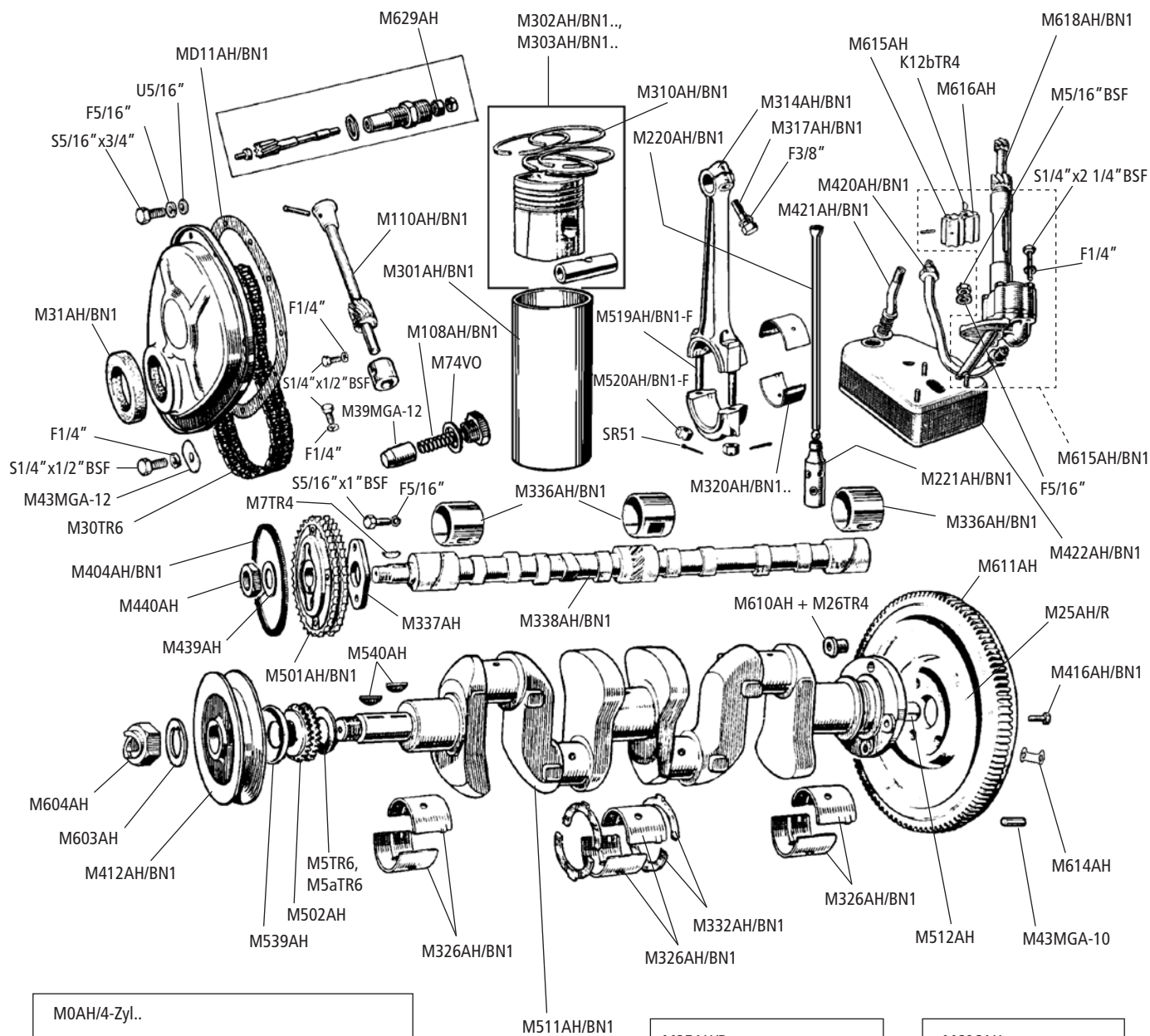

*) Beachten Sie bitte auch die Hinweise zu den Austauschmotoren auf S.7 und S. 23 ! / Please refer to our notes on page 7 and 23 !

Motor / Internal Engine BN1-BN2

No.	Bezeichnung	Description	Type	Anzahl/Qty.
M0AH/4-Zyl	Austausch-Motor mit Zylinderkopf *)	exchange engine *)	BN1-BN2	1
M0AH/4-Zyl/LM	Austausch-Motor mit Zylind.kopf „Le-Mans“ *)	exchange engine „Le-Mans“ *)	BN1-BN2	1
M5TR6	Distanzscheibe Kurbelwelle 0,006"	packing washer 0,006"	BN1-BN2	A/R
M5aTR6	Distanzscheibe Kurbelwelle 0,004"	packing washer 0,004"	BN1-BN2	A/R
M7TR4	Keil Kurbelwelle	key	BN1-BN2	1
MD11AH/BN1	Dichtung Steuerkettendeckel	gasket, timing cover	BN1-BN2	1
K12BTR4	Keil für Riemenscheibe	key, driving gear	BN1-BN2	1
MD24AH	Dichtung Ölfiltergehäuse	gasket, oil filter	BN1-BN2	1
M25AH/R	leichte Stahlschwungscheibe 8-Loch	flywheel assembly	BN1-BN2	1
M26TR4	Befestigungsschraube Schwungscheibe	bolt, flywheel	BN1-BN2	4
M30TR6	Steuerkette	timing chain	BN1-BN2	1
M31AH/BN1	Filzdichtring Steuerdeckel	oil seal, timing cover, felt	BN1-BN2	1
K33TR	Einweg-Ölfilterpatrone	throw away oil filter	BN1-BN2	1
M39MGA-12	Überdruckventil Öldruck	oil pressure relief valve	BN1-BN2	1
M43MGA-12	Flache Scheibe (oval)	washer, oval	BN1-BN2	5
M43MGA-10	Paßstift Kupplungsscheibe	dowel, for clutch cover	BN1-BN2	2
SR51	Splint 2.5 mm x 32mm	cotter pin	BN1-BN2	8
M74VO	Kupferdichtung 3/4"	washer, copper	BN1-BN2	1
M97TR4	Ölfilter	oil filter	BN1-BN2	1
M108AH/BN1	Öldruck-Feder	spring	BN1-BN2	1
M110AH/BN1	Antriebswelle Verteiler	driving spindle, distributor	BN1-BN2	1
S1/4"x1/2"BSF	Schraube Verteilerwelle	setscrew, for bush	BN1-BN2	1
M140AH	Einweg-Ölfilter Adapter	adaptor, throw away oil filter	BN1>213325-BN2	1
M140AH/BN1	Einweg-Ölfilter Adapter	adaptor, throw away oil filter	BN1<213324	1
M220AH/BN1	Stößelstange	pushrod	BN1-BN2	8
M221AH/BN1	Stößeltasse	tappet	BN1-BN2	8
M301AH/BN1	Laufbuchse	piston liner	BN1-BN2	4
M302AH/BN1-ST	Kolben-Satz (4) STD CR7.5:1	piston set (4) STD CR7.5:1	BN1-BN2	1
M302AH/BN1-20	Kolben-Satz (4).020" CR7.5:1	piston set (4).020" CR7.5:1	BN1-BN2	1
M302AH/BN1-30	Kolben-Satz (4).030" CR7.5:1	piston set (4).030" CR7.5:1	BN1-BN2	1
M302AH/BN1-40	Kolben-Satz (4).040" CR7.5:1	piston set (4).040" CR7.5:1	BN1-BN2	1
M302AH/BN1-60	Kolben-Satz (4).060" CR7.5:1	piston set (4).060" CR7.5:1	BN1-BN2	1
M303AH/BN1-ST	Kolben-Satz (4) STD CR 8.6:1	piston set (4) STD CR 8.6:1	BN1-BN2 (100M)	1
M303AH/BN1-20	Kolben-Satz (4).020" CR8.6:1	piston set (4).020" CR8.6:1	BN1-BN2 (100M)	1
M303AH/BN1-30	Kolben-Satz (4).030" CR8.6:1	piston set (4).030" CR8.6:1	BN1-BN2 (100M)	1
M303AH/BN1-40	Kolben-Satz (4).040" CR8.6:1	piston set (4).040" CR8.6:1	BN1-BN2 (100M)	1
M303AH/BN1-60	Kolben-Satz (4).060" CR8.6:1	piston set (4).060" CR8.6:1	BN1-BN2 (100M)	1
M310AH/BN1-ST	Kolbenringe-Satz STD für 4 Kolben	piston ring set STD (for 4 pistons)	BN1-BN2	1
M310AH/BN1-20	Kolbenringe-Satz .020" für 4 Kolben	piston ring set .020" (for 4 pistons)	BN1-BN2	1
M310AH/BN1-30	Kolbenringe-Satz .030" für 4 Kolben	piston ring set .030" (for 4 pistons)	BN1-BN2	1
M310AH/BN1-40	Kolbenringe-Satz .040" für 4 Kolben	piston ring set .040" (for 4 pistons)	BN1-BN2	1
M310AH/BN1-60	Kolbenringe-Satz .060" für 4 Kolben	piston ring set .060" (for 4 pistons)	BN1-BN2	1
M314AH/BN1	Pleuel gebraucht aufgearbeitet	connecting rod, reconditioned	BN1-BN2	4
M317AH/BN1	Schraube Kolbenbolzenbefestigung	bolt, clamping rod to gudgeon pin	BN1-BN2	4
M320AH/BN1STD	Pleuellager-Satz STD	rod bearing set STD	BN1-BN2	1
M320AH/BN1-10	Pleuellager-Satz .010"	rod bearing set .010"	BN1-BN2	1
M320AH/BN1-20	Pleuellager-Satz .020"	rod bearing set .020"	BN1-BN2	1
M320AH/BN1-30	Pleuellager-Satz .030"	rod bearing set .030"	BN1-BN2	1
M320AH/BN1-40	Pleuellager-Satz .040"	rod bearing set .040"	BN1-BN2	1
M320AH/BN1-50	Pleuellager-Satz .050"	rod bearing set .050"	BN1-BN2	1
M320AH/BN1-60	Pleuellager-Satz .060"	rod bearing set .060"	BN1-BN2	1
M326AH/BN1STD	Hauptlager-Satz STD	main bearing set STD	BN1-BN2	1
M326AH/BN1-10	Hauptlager-Satz 0.010"	main bearing set 0.010"	BN1-BN2	1
M326AH/BN1-50	Hauptlager-Satz 0.050"	main bearing set 0.050"	BN1-BN2	1
M326AH/BN1-20	Hauptlager-Satz 0.020"	main bearing set 0.020"	BN1-BN2	1
M326AH/BN1-30	Hauptlager-Satz 0.030"	main bearing set 0.030"	BN1-BN2	1
M326AH/BN1-40	Hauptlager-Satz 0.040"	main bearing set 0.040"	BN1-BN2	1
M326AH/BN1-60	Hauptlager-Satz 0.060"	main bearing set 0.060"	BN1-BN2	1

– Fortsetzung nächste Seite

- to be continued next page

Motor / Internal Engine BN1-BN2

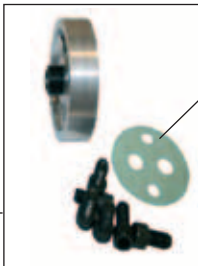
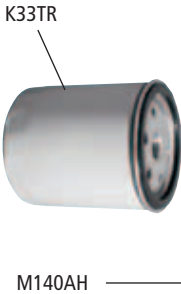
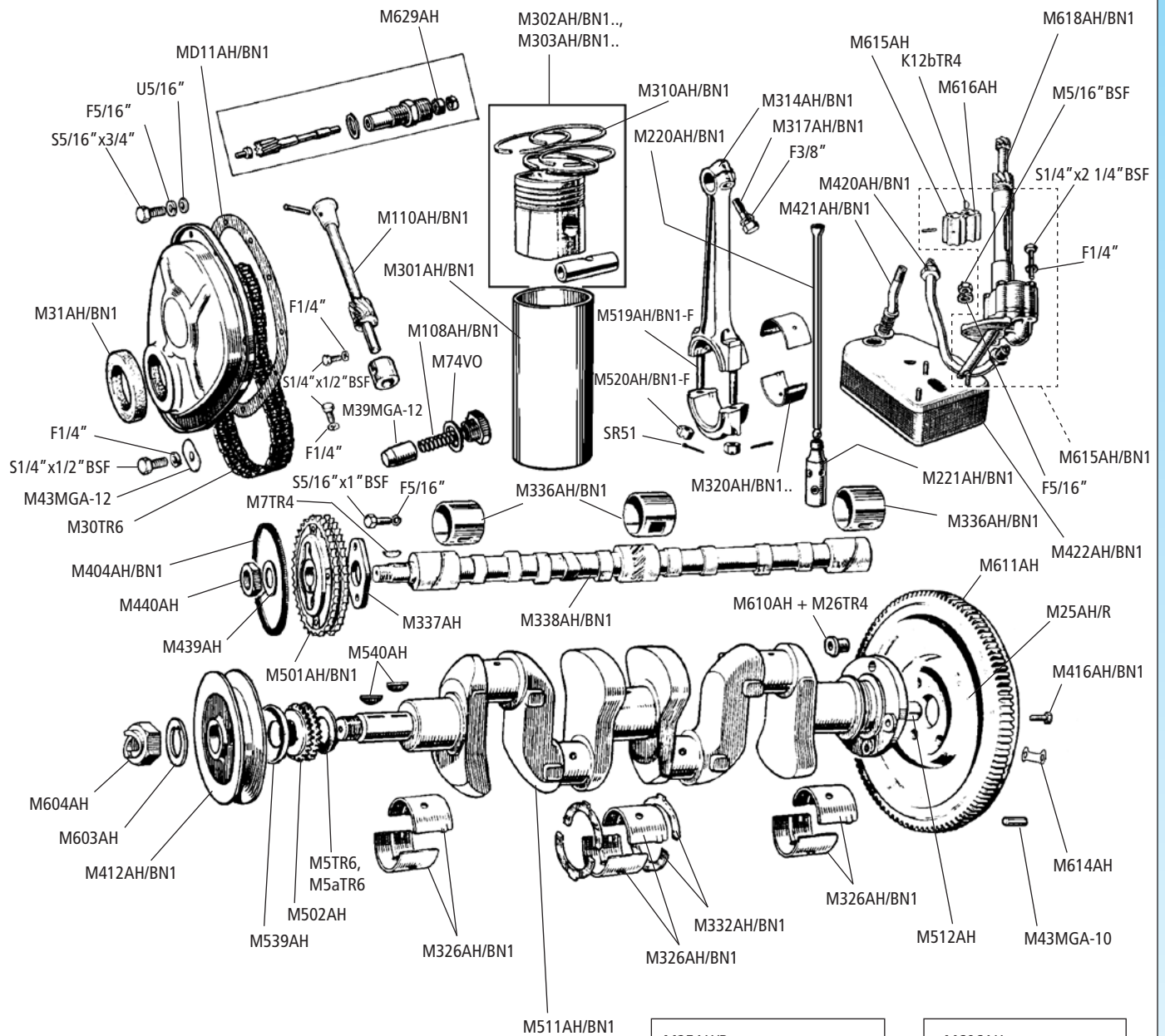

M140AH

Motor / Internal Engine BN1-BN2

No.	Bezeichnung	Description	Type	Anzahl/Qty.
M332AH/BN1STD	Anlaufscheiben-Satz STD	thrustwasher set STD	BN1-BN2	1
M332AH/BN1-05	Anlaufscheiben-Satz 0.005"	thrustwasher set 0.005"	BN1-BN2	1
M332AH/BN1-10	Anlaufscheiben-Satz 0.010"	thrustwasher set 0.010"	BN1-BN2	1
M336AH/BN1	Nockenwelle-Lager-Satz	cam bearing set	BN1-BN2	1
M337AH	Führungsplatte Nockenwelle	locating plate	BN1-BN2	1
M338AH/BN1	Nockenwelle STD	camshaft, STD	BN1-BN2	1
M338AH/BN1-LM	Nockenwelle „Le-Mans“	camshaft, Le Mans type	BN1-BN2	1
M404AH/BN1	Gummi-Ring Kettenrad Nockenwelle	tensioner ring, timing chain	BN1-BN2	1
M412AH/BN1	Keilriemenscheibe Kurbelwelle	pulley, crankshaft	BN1-BN2	1
M416AH/BN1	Bolzen Schwungscheibe/Kurbelwelle	bolt, flywheel to crankshaft	BN1-BN2	4
M420AH/BN1	Öldruck Zufuhrleitung Ölpumpe, flexibel	pipe, oil delivery	BN1-BN2	1
M421AH/BN1	Öldruck Rücklaufleitung ab Ölpumpe	pipe, oil return	BN1-BN2	1
M422AH/BN1	Sieb Ölpumpe	oil strainer	BN1-BN2	1
M439AH	Sicherungsblech Kettenrad Nockenwelle	tab washer	BN1-BN2	1
M440AH	Mutter Kettenrad Nockenwelle	nut	BN1-BN2	1
M501AH/BN1	Kettenrad Nockenwelle, ohne Bleche mit Nieten	camshaft gear (w/o rivets)	BN1-BN2	1
M502AH	Kettenrad Kurbelwelle	crankshaft gear	BN1-BN2	1
M511AH/BN1	AT-Kurbelwelle	crankshaft, remanufactured, exchange	BN1-BN2	1
M512AH	Pilotlager Kurbelwelle	pilot bush	BN1-BN2	1
M519AH/BN1	Pleuelschrauben-Paar	bolt for cap, pair	BN1-BN2	4
M520AH/BN1	Mutter Pleuelschraube, selbstsichernd	nut, self-locking	BN1-BN2	8
M539AH	Ölschleuderblech	oil thrower	BN1-BN2	1
M540AH	Keil Kurbelwelle	key	BN1-BN2	2
M603AH	Sicherungsblech Kurbelwelle	lockwasher	BN1-BN2	1
M604AH	Mutter Kettenrad/Kurbelwelle	nut, starting (crank dog nut)	BN1-BN2	1
M606AH	Keilriemenscheibe für 3/8"-Riemen inkl. Hochleistungsschwingungsdämpfer	pulley and damper, crankshaft 3/8"	BN1-BN2	1
M610AH	Mutter für M26TR4	nut for M26TR4	BN1-BN2	4
(M26TR4)	Befestigungsschraube Schwungscheibe	bolt, flywheel	BN1-BN2	4
M611AH	Anlasser-Zahnkranz Schwungscheibe	ring gear	BN1-BN2	1
M614AH	Sicherungsblech Schwungscheibe	lockwasher	BN1-BN2	2
M615AH	Zahnrad Ölpumpe	driving gear	BN1-BN2	1
M615AH/BN1	Ölpumpe ohne Antriebswelle	oil pump assembly, w/o driving spindle	BN1-BN2	1
M616AH	Zahnrad Ölpumpe	driving gear	BN1-BN2	1
M618AH/BN1	Antriebswelle Ölpumpe	driving spindle	BN1-BN2	1
M629AH	Öldichting Drehzahlmesserwelle	oil seal, pinion	BN1-BN2	1
MÖ	Motoröl 20W50, je Liter	motor oil 20W50, per litre		A/R
MÖRACE	Motoröl 20W50 Racing für Sportzwecke, je Liter	motor oil 20W50 Racing, for competition use, per litre		A/R

Hinweise
Notes

*) Überholung nur des eigenen Motors möglich – wir empfehlen zusätzlich die Montage eines neuen Aluminium-Zylinderkopfes (ZK1AH/BN1-ALU).

Alle Austauschmotoren werden in unserer eigenen Werkstatt überholt. Alle Kurbelwellen werden auf Risse überprüft, geschliffen, nitrirt und nachgewuchtet. Wir gewähren auf alle AT-Motoren 2 Jahre Garantie ohne Kilometerbegrenzung! Selbstverständlich bauen wir auf Wunsch Ihren Motor auch ein und aus.

Beachten Sie bitte auch die Hinweise zu den Austauschmotoren auf Seite 23 !

*) Only rebuilding of your existing engine possible! We would recommend the mounting of a new aluminium cylinder head (no: ZK1AH/BN1-ALU).

All exchange engines will be refurbished and remounted in our own workshop. All rebuilt crank shafts will be nitrated. For our rebuilt engines we guarantee for two years without kilometer limitation. Of course, we can dismount/ mount the engine in your car.

Please refer to our notes "exchange parts" on page 23 !



Motor / External Engine BN1-BN2

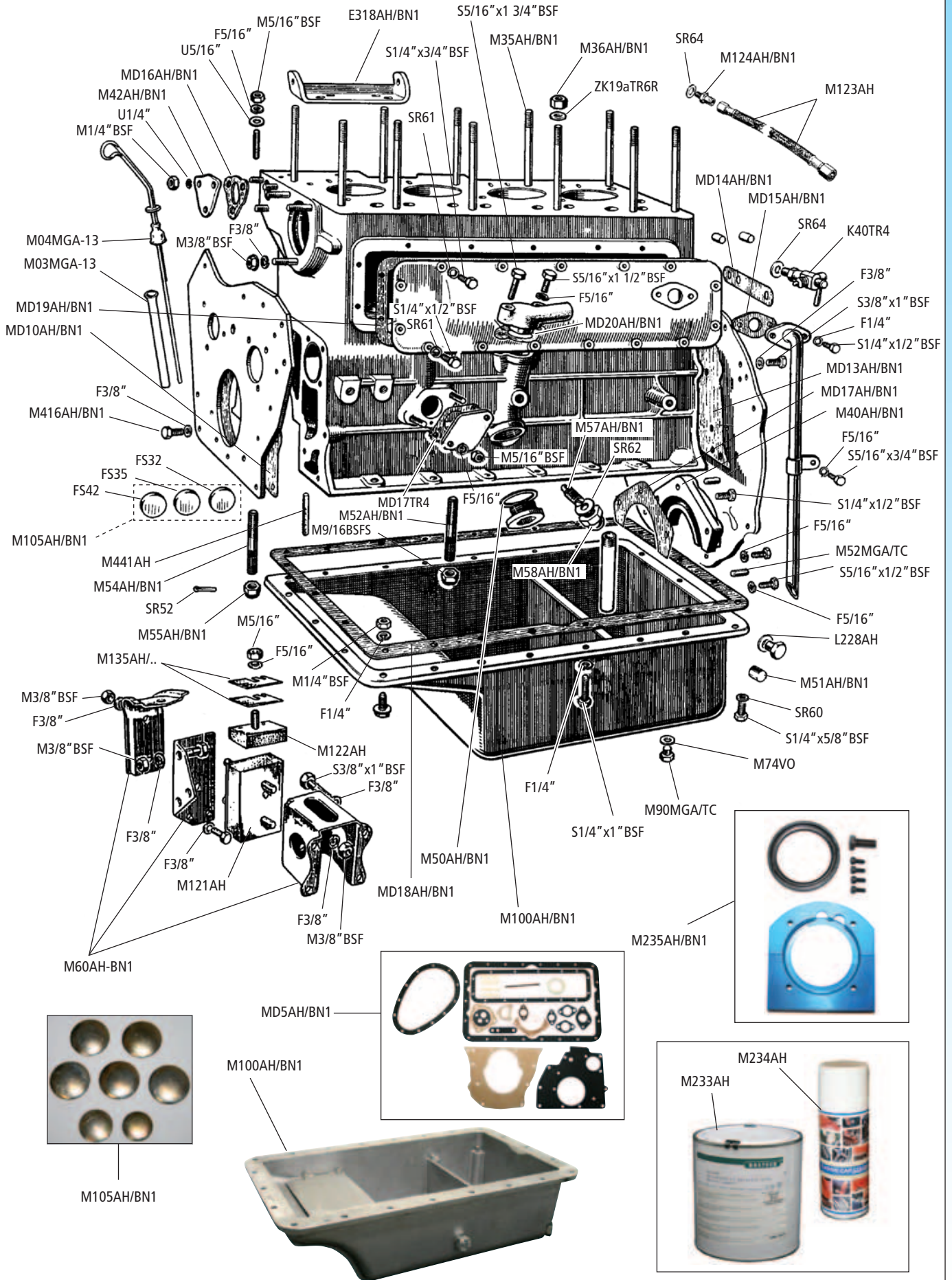

Motor / External Engine BN1-BN2

No.	Bezeichnung	Description	Type	Anzahl/Qty.
M03MGA-13	Führungsrohr Ölmeßstab	tube, dipstick	BN1-BN2	1
M04MGA-13	Gummikappe Ölmeßstab	dust cap	BN1-BN2	1
MD5AH/BN1	unterer Motordichtsatz	engine gasket set, buttom	BN1-BN2	1
MD10AH/BN1	Motorplattendichtung vorne	gasket, front mounting plate	BN1-BN2	1
MD11AH/BN1	Dichtung Steuerkettendeckel	gasket, timing cover	BN1-BN2	1
MD13AH/BN1	Motorplattendichtung hinten	gasket, rear mounting plate	BN1-BN2	1
MD14AH/BN1	Motorplattendichtung oben/hinten	gasket, rear mounting plate, top	BN1-BN2	1
MD15AH/BN1	Dichtung Entlüftungsrohr	gasket, vent pipe	BN1-BN2	1
MD16AH/BN1	Dichtung Wassergalerie vorne	gasket, front water gallery	BN1-BN2	1
MD17TR4	Benzinpumpendichtung	gasket	BN1-BN2	1
MD17AH/BN1	Dichtung für Öldichtgehäuse	gasket oil thrower	BN1-BN2	1
MD18AH/BN1	Ölwannen-Dichtung	gasket, sump	BN1-BN2	1
MD19AH/BN1	Dichtung Motor-Seitendeckel	gasket	BN1-BN2	1
ZK19aTR6R	U-Scheibe spezial hart 7/16" parallel geschliffen, ohne Fase	washer, plain, reinforced	BN1-BN2	11
MD20AH/BN1	Dichtung Drehzahlmesser	gasket, tachometer	BN1-BN2	1
M35AH/BN1	Stehbolzen Zylinderkopf	stud, cylinder head	BN1-BN2	11
M36AH/BN1	Mutter Zylinderkopf	nut, cylinder head stud	BN1-BN2	11
FSF32	Froststopfen 32 mm	core plug 32 mm	BN1-BN2	1
FSF35	Froststopfen 35 mm	core plug 35 mm	BN1-BN2	1
FSF42	Froststopfen 42 mm	core plug 42 mm	BN1-BN2	5
K40TR4	Wasserablasshahn	drain tap	BN1-BN2	1
M40AH/BN1	Öldichtgehäuse hinten/oben	oil thrower, block	BN1-BN2	1
M42AH/BN1	Deckel Wasserführung vorne	blanking plate, front cover and water gallery	BN1-BN2	1
M50AH/BN1	Kupferdichtring	washer, for plug	BN1-BN2	2
M51AH/BN1	Stopfen Öl Kühler Adapter	plug, oil cooler boss	BN1-BN2	1
SR52	Splint 3.2 mm	cotter pin 3.2 mm	BN1-BN2	6
M52MGA/TC	Passstift Motorplatte unten hinten	dowel, rear engine plate	BN1-BN2	2
M52AH/BN1	Stehbolzen Hauptlagerdeckel	stud main bearing cap	BN1<207105	6
M9/16" BSFS	Mutter für Hauptlagerdeckel	nut, main bearing cap	BN1<207105	6
M54AH/BN1	Stehbolzen Hauptlagerdeckel	stud, main bearing cap	BN1>207106, BN2	6
M55AH/BN1	Mutter f. Hauptlagerdeckel selbstsichernd	nut	BN1>207106, BN2	6
M57AH/BN1	Halteschraube Ölpumpenantrieb	locating screw, oil pump	BN1-BN2	1
M58AH/BN1	Hutmutter Ölpumpenantrieb	cap nut	BN1-BN2	1
M60AH-BN1	Satz Motoraufhängung	rubber mounting, set	BN1-BN2	2
SR60	CU-Dichtring 1/4"	washer, copper 1/4"	BN1-BN2	15
SR61	CU-Dichtring 5/16"	washer, copper 5/16"	BN1-BN2	15
SR62	CU-Dichtring 3/8"	washer, copper 3/8"	BN1-BN2	1
SR64	CU-Dichtring 1/2"	sealing washer 1/2"	BN1-BN2	A/R
M74VO	Kupferdichtung 3/4" Innendurchmesser	washer, copper	BN1-BN2	1
M90MGA/TC	Ölablaßschraube	plug, oil drain	BN1-BN2	1
M90MGA/TC-M	Ölablaßschraube magnetisch	plug, oil drain, magnetic	BN1-BN2	1
M100AH/BN1	Aluminium Ölwanne	sump, alloy	BN1-BN2	1
M105AH/BN1	Froststopfen-Satz	core plug set, cylinder block	BN1-BN2	1
M121AH	Motoraufhängungsgummi groß unten	engine mount	BN1-BN2	2
M122AH	Gummi-Lager Motoraufhängung vo. ob. klein	buffer, engine mounting	BN1-BN2	2
M123AH	Schlauch Öldruckanzeige	oil line, flexible	BN1-BN2	1
M124AH/BN1	Doppelnippel Anschluss Öldruckschlauch	union	BN1-BN2	1
M135AH/1.50	Unterlage Motoraufhängung 1.50 mm	packing piece 1.50 mm	BN1-BN2	A/R
M135AH/1.00	Unterlage Motoraufhängung 1.00 mm	packing piece 1.00 mm	BN1-BN2	A/R
L228AH	Fiberscheibe 1/2 x 3/4"	sealing washer, fiber	BN1-BN2	A/R
M233AH	Motorfarbe 1l metallic grün	engine paint, metallic green, 1 l	BN1-BN2	1
M234AH	Sprühdose Motorfarbe metallic grün, 400ml	engine paint, metallic green, aerosol, 400 ml	BN1-BN2	1
M235AH/BN1	Umrüstsat auf Simmerring (Motorblock muss bearbeitet werden – ausführliche Montageanleitung finden Sie im Internet!)	mounting kit oil seal (block must be modified – fitting instructions on our web site!)	BN1-BN2	1
E318AH/BN1	Halter Lichtmaschine an Motorblock	bracket, dynamo	BN1-BN2	1
M416AH/BN1	Bolzen Schwungscheibe/Kurbelwelle	bolt, plate to block	BN1-BN2	5
M441AH	Stopf-Filz Motorbock	plug, felt front and rear main bearing caps	BN1-BN2	4
MÖ	Motoröl 20W50, je Liter	motor oil 20W50, per litre		A/R
MÖRACE	Motoröl 20W50 Racing für Sportzwecke, je Liter	motor oil 20W50 Racing, for competition use, per litre		A/R

Zylinderkopf / Cylinder Head BN1-BN2

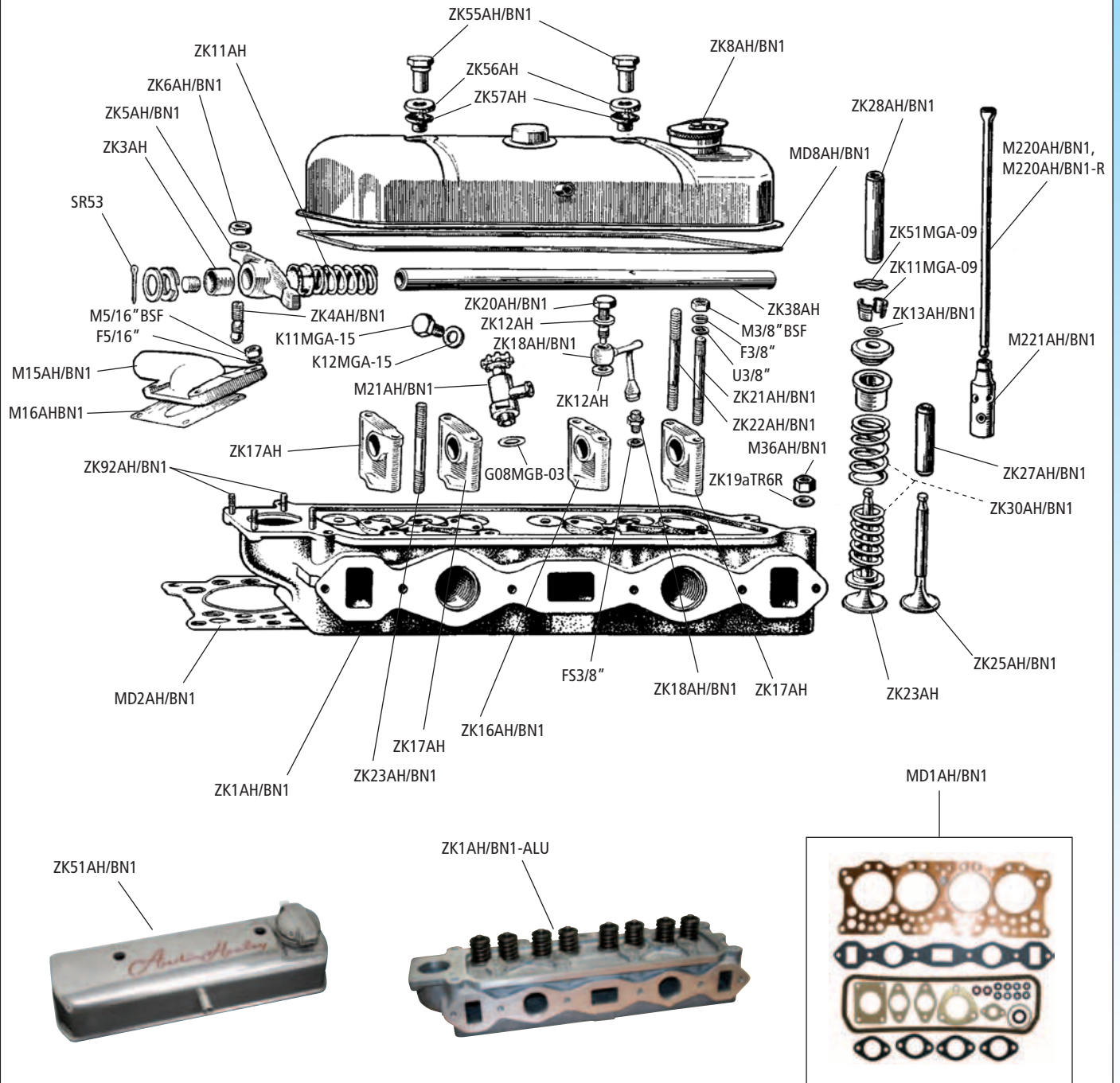

Zylinderkopf / Cylinder Head BN1-BN2

No.	Bezeichnung	Description	Type	Anzahl/Qty.
ZK1AH/BN1	AT-Zylinderkopf	cylinder head, exchange	BN1-BN2	1
ZK1AH/BN1-ALU	Zylinderkopf Aluminium	cylinder head, aluminium	BN1-BN2	1
MD1AH/BN1	Zylinderkopf-Dichtsatz	head gasket set	BN1-BN2	1
MD2AH/BN1	Zylinderkopf-Dichtung	head gasket	BN1-BN2	1
ZK3AH	Lagerbuchse Kipphebel	bush, rocker arm	BN1-BN2	8
ZK4AH/BN1	Einstellschraube Ventile	adjuster, rocker arm	BN1-BN2	8
ZK5AH/BN1	Kipphebel	rocker arm, with bush	BN1-BN2	8
ZK6AH/BN1	Mutter Ventileinstellschraube	locknut	BN1-BN2	8
G08MGB-09	Fiberscheibe an Schalter auf Getriebedeckel	washer	BN1-BN2	A/R
MD8AH/BN1	Ventildeckel-Dichtung	gasket, rocker cover	BN1-BN2	1
ZK8AH/BN1	Öleinfülldeckel Ventildeckel	oil filler cap	BN1-BN2	1
K11MGA-15	Verschlußstopfen Heizung	plug, heater boss	BN1	1
ZK11MGA-09	Klemmkeil Ventile	cotter, valve retaining	BN1-BN2	16
ZK11AH	Feder zwischen Kipphebel	spring	BN1-BN2	3
ZK12AH	Dichtscheibe Banjo Schraube	washer, fibre	BN1-BN2	2
K12MGA-15	Dichtscheibe	washer	BN1-BN2	1
ZK13AH/BN1	Gummi-Dichtring Ventile	oil seal, valve stem	BN1-BN2	8
M15AH/BN1	Deckel Thermostat-Gehäuse	water outlet elbow	BN1-BN2	1
M16AH/BN1	Dichtung Thermostat-Gehäuse	gasket	BN1-BN2	1
ZK16AH/BN1	Lagerbock Kipphebelwelle mit Gewindeloch	rocker pedestal, with tapped hole	BN1-BN2	1
ZK17AH	Lagerbock Kipphebelwelle	rocker pedestal, without tapped hole	BN1-BN2	3
ZK18AH/BN1	Adapter Kipphebelschmierung	union, in cylinder head	BN1-BN2	1
ZK19aTR6R	U-Scheibe spezial hart 7/16" parallel geschliffen, ohne Fase	washer plain, reinforced 7/16"	BN1-BN2	11
ZK19AH/BN1	Leitung Öldruck/Kipphebelwelle	oil feed pipe	BN1-BN2	1
ZK20AH/BN1	Hohlschraube Ölleitung Zylinderkopf	bolt, shaft locating	BN1-BN2	1
M21AH/BN1	Heizungsventil	heater control valve	BN1-BN2	1
ZK21AH/BN1	Stehbolzen Kipphebelwelle kurz	stud, rocker pedestal, short	BN1-BN2	4
ZK22AH/BN1	Stehbolzen Kipphebelwelle lang	stud, rocker pedestal, long	BN1-BN2	4
ZK23AH/BN1	Stehbolzen Ventildeckel	stud, rocker cover	BN1-BN2	2
ZK23AH	Ventil Einlass	valve, inlet	BN1-BN2	4
ZK25AH/BN1	Ventil Auslass	valve, exhaust	BN1-BN2	4
ZK27AH/BN1	Ventilführung Einlass	valve guide, inlet	BN1-BN2	4
ZK27AH/BN1-B	Ventilführung Einlass Bronze	valve guide, inlet, bronze	BN1-BN2	4
ZK28AH/BN1	Ventilführung Auslass	valve guide, exhaust	BN1-BN2	4
ZK28AH/BN1-B	Ventilführung Auslass Bronze	valve guide, exhaust, bronze	BN1-BN2	4
ZK30AH/BN1	Ventilfeder-Satz (16 Federn)	valve spring set	BN1-BN2	1
M36AH/BN1	Mutter Zylinderkopf	nut, cylinder head stud	BN1-BN2	11
ZK38AH	Kipphebelwelle	rocker shaft	BN1-BN2	1
ZK51MGA-09	Klammer Ventilkeile	circlip	BN1-BN2	8
ZK51AH/BN1	Ventildeckel Alu mit Schriftzug poliert	aluminium valve cover, with lettering	BN1-BN2	4
SR53	Splint 2.0 mm	cotter pin	BN1-BN2	2
ZK55AH/BN1	Hutmutter Ventildeckel Edelstahl	cap nut	BN1-BN2	2
ZK56AH	Abdeckkappe Edelstahl (Paar)	cup washer, pair	BN1-BN2	1
ZK57AH	Abdeckkappe Gummi Ventildeckel	bush	BN1-BN2	2
ZK92AH/BN1	Stehbolzen Thermostatgehäuse	stud	BN1-BN2	4
M220AH/BN1	Stößelstange	pushrod	BN1-BN2	8
M220AH/BN1-R	Rohrstößelstange verstärkt	tubular pushrod uprated	BN1-BN2	8
M221AH/BN1	Stößeltasse	tappet0	BN1-BN2	8

Ansaugbrücke / Manifolds BN1-BN2

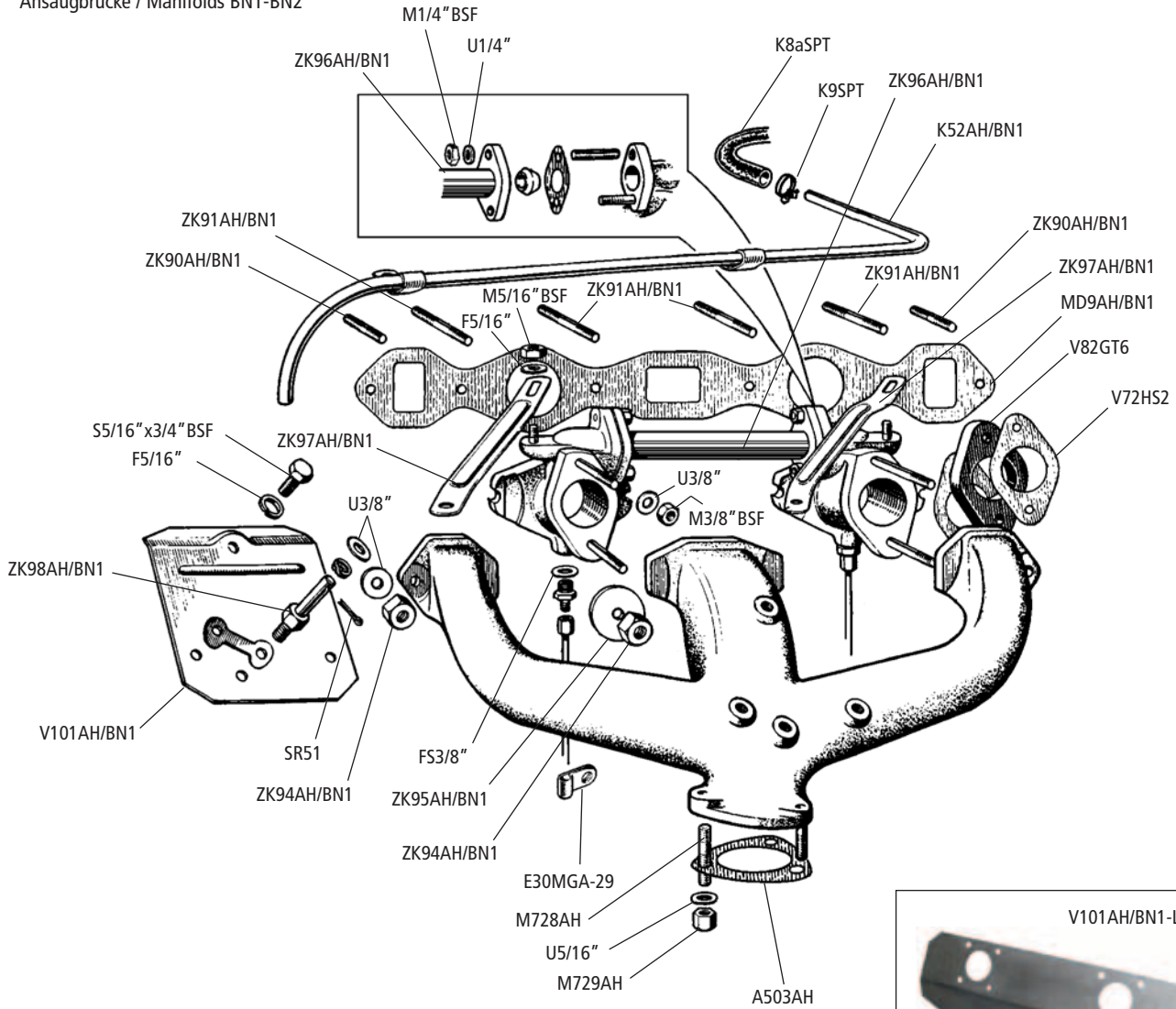

Le Mans Kit Vergaser / Le Mans carburettor kit BN1-BN2

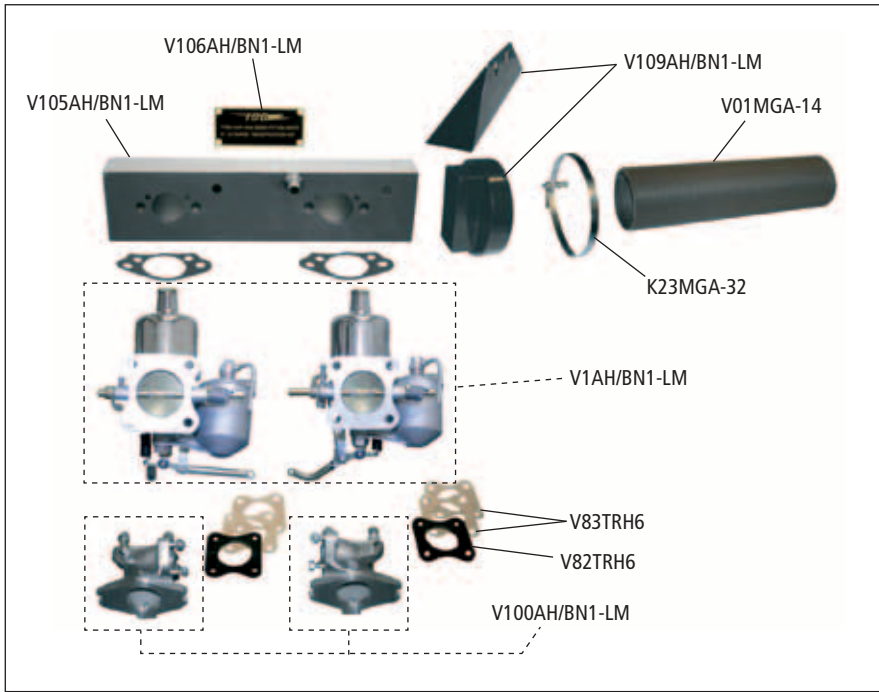

Ansaugbrücke / Manifolds BN1-BN2

No.	Bezeichnung	Description	Type	Anzahl/Qty.
K8aSPT	Schlauch 1/2" / lfdm	hose, 1/2" per meter	BN1-BN2	A/R
K9SPT	Schlauchschelle 12-22mm Heizung	clip, hose	BN1-BN2	2
MD9AH/BN1	Einlaß/Auslaßdichtung	manifold gasket	BN1-BN2	1
E30MGA-29	Befestigungsclip	clip, drain pipe	BN1-BN2	2
SR51	Splint 2.5 mm x 32mm	cotter pin	BN1-BN2	1
K52AH/BN1	Wasserrohr Heizung	feed pipe, copper	BN1-BN2	1
V72HS4	Ansaugstutzendichtung HS4-Vergaser	gasket carb to manifold HS4 carb.	BN1<139915	2
V72HS2	Ansaugstutzendichtung HS2-Vergaser	gasket carb to manifold HS2 carb.	BN1>139915, BN2	4
V82GT6	Isolierflansch	distance pipe	BN1>139915, BN2	2
ZK90AH/BN1	Stehbolzen Einlass-Auslass an Zylinderkopf (kurz)	stud, head to exhaust manifold, short	BN1-BN2	2
ZK91AH/BN1	Stehbolzen Einlass-Auslass an Zylinderkopf (lang)	stud, head to exhaust manifold, long	BN1-BN2	4
ZK94AH/BN1	Messing-Mutter Stehbolzen Einlass-Auslass	nut, brass	BN1-BN2	6
ZK95AH/BN1	Scheibe Krümmermutter	washer, yoke	BN1-BN2	4
ZK96AH/BN1	Ausgleichrohr mit Flansch	balance pipe	BN1-BN2	1
ZK97AH/BN1	Paar Abstützungen-Ansaugbrücke	support set, carburettor	BN1-BN2	1
ZK98AH/BN1	Bolzen Umlenkung Gasgestänge	fulcrum pin, bellcrank lever	BN1-BN2	1
V101AH/BN1	Hitzeschild Ansaugkrümmer	heat shield	BN1-BN2	1
A503	Auspuff-Hosenrohrdichtung	exhaust flange gasket	BN1-BN2	1
M728AH	Stehbolzen Auspuff-Rohr	stur	BN1-BN2	3
M729AH	Mutter Auspuff-Rohr Messing	nut, brass	BN1-BN2	3

Le Mans Kit Vergaser / Le Mans carburettor kit BN1-BN2

No.	Bezeichnung	Description	Type	Anzahl/Qty.
V01MGA-14	Frischlufschlauch (Vergaser)	air hose (carburettor)	BN1-BN2	1
V1AH/BN1-LM	Vergaser-Paar H6 „Le Mans“	carburettor H6 „Le Mans“, pair	BN1-BN2	1
K23MGA-32	Schlauchschelle	clip, hose	BN1-BN2	1
V82TRH6	Isolierflansch	distance pipe	BN1-BN2	2
V83TRH6	Dichtung	gasket	BN1-BN2	4
V92TRH6	Luftfilterdichtung	gasket	BN1-BN2	2
V100AH/BN1-LM	Ansaugkrümmer-Paar „Le Mans“ für 2x H6-Vergaser	manifolds, pair „Le Mans“ (for 2x H6-carb.)	BN1-BN2	1
V101AH/BN1-LM	Hitzeschild Ansaugkrümmer für „Le Mans“ Kit	heat shield (for „Le Mans“ kit)	BN1-BN2	1
V105AH/BN1-LM	Luftfilterkasten „Le Mans“ („Cold Airbox“)	air filter box „Le Mans“ (Cold Airbox)	BN1-BN2	1
V106AH/BN1-LM	Messingplakette Luftfilter „Le Mans“	plate, brass, air filter box „le Mans“	BN1-BN2	1
V107AH/BN1-LM	Halter Spritzwand/Luftfilter „Le Mans“	bracket, body/air filterbox „Le Mans“	BN1-BN2	1
V109AH/BN1-LM	Verbindung Frischluftschlauch/Luftfilterkasten	connecting air hose/air filter box	BN1-BN2	1

Motorblock / External Engine BN4, BN6, BN7, BT7, BJ7, BJ8

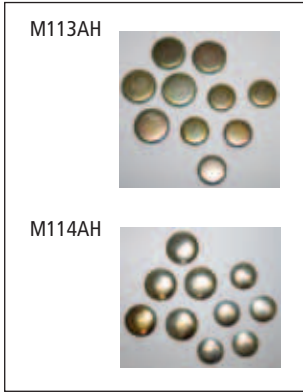
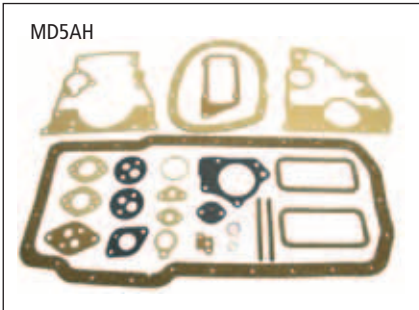
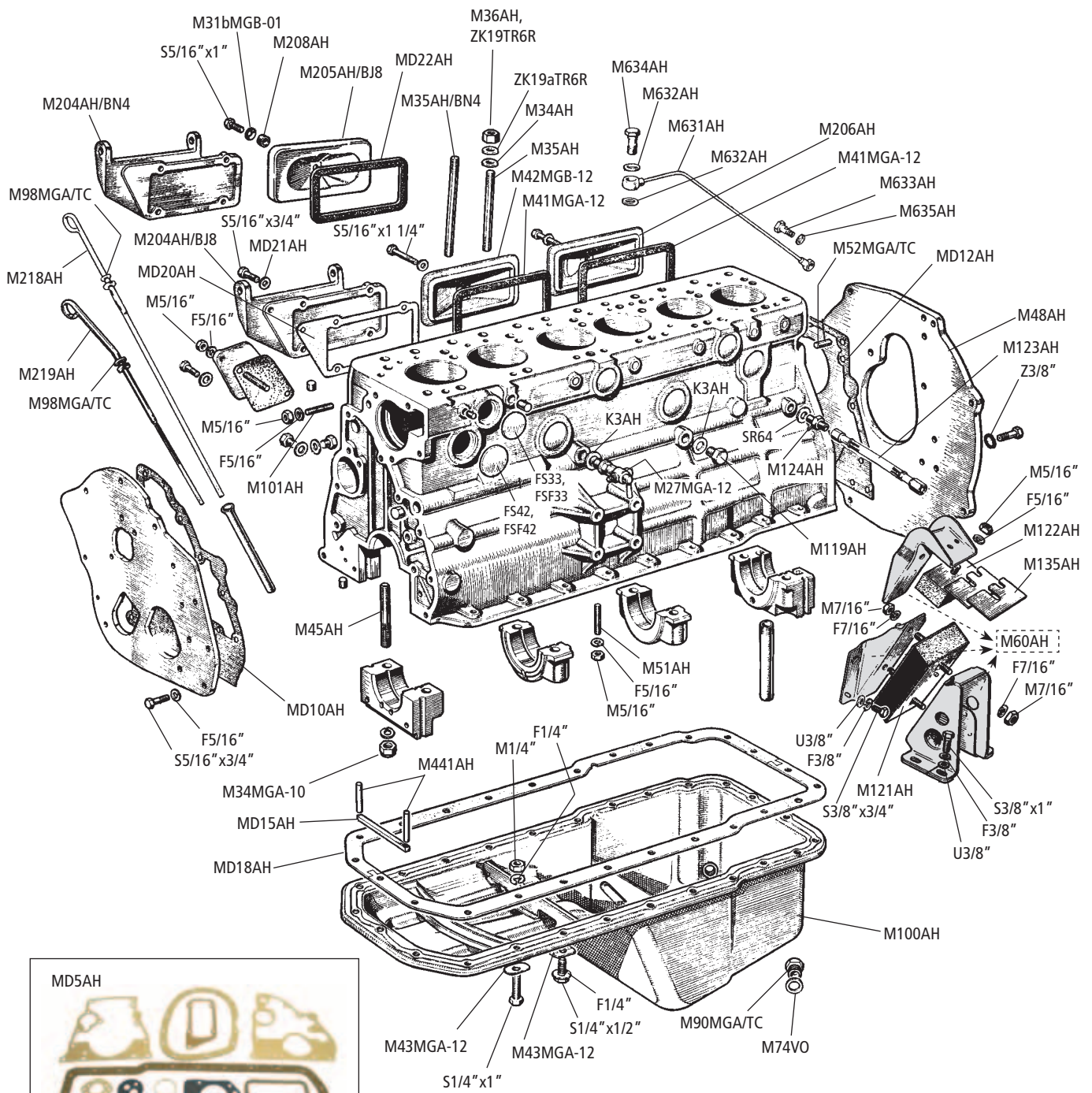

Motorblock / External Engine BN4, BN6, BN7, BT7, BJ7, BJ8

No.	Bezeichnung	Description	Type	Anzahl/Qty.
K3AH	Fiberscheibe 1/2 x 3/4"	washer, for plug	BN4, BN6, BN7, BT7, BJ7, BJ8	1
MD5AH	unterer Motordichtsatz	engine gasket set, bottom	BN4-BJ8	1
MD10AH	Motorplattendichtung vorne	gasket, front mounting plate	BN4, BN6, BN7, BT7, BJ7, BJ8	1
MD11AH	Dichtung Steuerkettendichtung	gasket, timing cover	BN4, BN6, BN7, BT7, BJ7, BJ8	1
MD18AH	Ölwannen-Dichtung	gasket, sump	BN4, BN6, BN7, BT7, BJ7, BJ8	1
MD20AH	Dichtung Deckel Motorseite vorne	gasket, front side cover	BN4-BJ8	1
ZK19TR6R	Zylinderkopfmutter hochfest 12-kt 7/16"-20	nut, cylinder head, high strenght	BN4-BJ8	16
ZK19aTR6R	U-Scheibe spezial hart 7/16" parallel geschliffen, ohne Fase	washer, plain, high tensile	BN4-BJ8	16
MD21AH	Unterlagscheibe 5/16"	washer, plain	BN4-BJ8	5
MD22AH	Dichtung Deckel Motorseite mitte	gasket, rubber, center	BJ8>29F-3954	1
M27MGA-12	Wasser-Ablasshahn	drain tap	BN4-BJ8	1
M31bMGB-01	Konkavscheibe Motor-Seitendeckel	washer, cup	BJ8>29F-3954	1
FS33	Froststopfen 1 5/16"	core plug 1 5/16"	BN7, BT7, BJ7, BJ8	4
FSF33	Froststopfen 1 5/16"	core plug 1 5/16"	BN4, BN6	4
FS42	Froststopfen 1 5/8"	core plug 1 5/8"	BN7, BT7, BJ7, BJ8	5
FSF42	Froststopfen 1 5/8"	core plug 1 5/8"	BN4, BN6	5
M34AH	Bronze U-Scheibe für M35AH/BN4	washer bronze to no. M35AH/BN4	BN4<48862	8
M34MGA-10	Hauptlager-Mutter	nut	BN4-BJ8	8
M35AH	Stehbolzen Zylinderkopf kurz	stud cylinder head, short	BN4, BN6, BN7, BT7, BJ7, BJ8	16
M35AH/BN4	Stehbolzen Zylinderkopf lang, Zylinderkopf mit 2x Einlass	stud, cylinder head long (cylinder head with 2x inlet)	BN4<48862	8
M36AH	Mutter Zylinderkopf	nut, cylinder head stud	BN4, BN6, BN7, BT7, BJ7, BJ8	16
M41MGA-12	Dichtung Seitendeckel Motor	gasket, cork	BN4, BN6, BN7, BT7, BJ7, BJ8<29F-3953	1
M42MGB-12	Motor-Seitendeckel hinten	side cover	BN4, BN6, BN7, BT7, BJ7, BJ8<29F-3953	1
M43MGA-12	Scheibe, oval	washer, oval	BN4, BN6, BN7, BT7, BJ7, BJ8	25
M45AH	Stehbolzen Hauptlagerdeckel	stud, main bearing cap	BN4, BN6, BN7, BT7, BJ7, BJ8	8
M48AH	Aluminium Motorplatte hinten	engine mounting plate, rear	BN4, BN6, BN7, BT7, BJ7, BJ8	1
M51AH	Stehbolzen UNF/UNC 5/16"x1 1/4" Ölpumpe	stud, mounting oil pump to crankcase	BN4, BN6, BN7, BT7, BJ7, BJ8	3
M52MGA/TC	Passstift Motorplatte unten	dowel, backplate to block	BN4, BN6, BN7, BT7, BJ7, BJ8	2
M60AH/L	Satz Motoraufhängungen verstärkt, links	mounting set, tightened, LH	BN4, BN6, BN7, BT7, BJ7, BJ8	1
M60AH/R	Satz Motoraufhängungen verstärkt, rechts	mounting set, tightened, RH	BN4, BN6, BN7, BT7, BJ7, BJ8	1
SR64	CU-Dichtring 1/2" (14x20x1)	washer, for union	BN4, BN6, BN7, BT7, BJ7, BJ8	1
M74VO	Kupferdichtung 3/4" Innen-Ø 20x26	washer, copper	BN4, BN6, BN7, BT7, BJ7, BJ8	1
M90MGA/TC	Ölablaßschraube	plug, oil drain	BN7, BT7, BJ7, BJ8	1
M90MGA/TC-M	Ölablaßschraube, magnetisch	plug, oil drain, magnetic	BN4-BJ8	1
M98MGA/TC	Gummikappe Ölmesstab	dust cap	BN4, BN6, BN7, BT7, BJ7, BJ8	1
M100AH	Aluminium Ölwanne	sump, oil	BN4, BN6, BN7, BT7, BJ7, BJ8	1
M101AH	Stehbolzen Wasserpumpe/Block	stud, water pump to block	BN4, BN6, BN7, BT7, BJ7, BJ8	4
M113AH	Froststopfen-Satz	core plug set	BN7, BT7, BJ7, BJ8	1
M114AH	Froststopfen-Satz	core plug set	BN4, BN6	1
M119AH	Stopfen Öldruckkanal Motorblock	plug, for oil filter feeder hole	BN4, BN6, BN7, BT7, BJ7, BJ8	1
M121AH	Motoraufhängung Gummi groß unten	engine mount	BN4, BN6, BN7, BT7, BJ7, BJ8	2
M122AH	Gummi-Lager Motoraufhängung vorne oben klein	rubber buffer, engine mounting	BN4, BN6, BN7, BT7, BJ7, BJ8	2
M123AH	Schlauch Öldruckanzeige	oil line, flexible	BN4, BN6, BN7, BT7, BJ7, BJ8	1
M124AH	Doppelnippel Anschluss Öldruckschlauch	union, for oil pressure pipe	BN4, BN6, BN7, BT7, BJ7, BJ8	1
M135AH/1.00	Unterlage Motoraufhängung 1.00 mm	packing piece 1.00 mm	BN4, BN6, BN7, BT7, BJ7, BJ8	A/R
M135AH/1.50	Unterlage Motoraufhängung 1.50 mm	packing piece 1.50 mm	BN4, BN6, BN7, BT7, BJ7, BJ8	A/R
M204AH/BJ8	Deckel Motor seitlich vorne	side cover, front	BJ8 ab 29K-H101, 29F-H3954	1
M204AH/BN4	Deckel Motor seitlich vorne	side cover, front	BN4, BN6, BN7, BT7, BJ7	1
M205AH/BJ8	Deckel Motor seitlich mitte	side cover, center	BJ8 ab 29K-H101, 29F-H3954	1
M206AH	Deckel Motor seitlich hinten	side cover, rear	BN4, BN6, BN7, BT7, BJ7, BJ8	1
M208AH	Gummi-Ring Motorseitendeckel	washer, sealing	BJ8>29F-3954	1
M218AH	Ölpeilstab	dipstick	BJ8>29K-H279	1
M219AH	Ölpeilstab	dipstick	BN4, BN6, BN7, BT7, BJ7, BJ8<29K-H278	1
M233AH	Motorfarbe 1l metallic grün	engine paint, metallic green, 1 l	BN4, BN6, BN7, BT7, BJ7, BJ8	A/R
M234AH	Sprühdose Motorfarbe metallic grün, 400ml	engine paint, metallic green, aerosol, 400 ml	BN4, BN6, BN7, BT7, BJ7, BJ8	A/R
M441AH	Stopf-Filz Motorblock	plug, felt	BN4, BN6, BN7, BT7, BJ7, BJ8	4
M631AH	Ölleitung Drehzahlwelle	oil feed pipe, tachometer drive	BN4, BN6, BN7, BT7, BJ7	1
M632AH	Dichtung Hohlschraube	washer	BN4, BN6, BN7, BT7, BJ7	2
M633AH	Hohlschraube	bolt, for union	BN4, BN6, BN7, BT7, BJ7	1
M634AH	Hohlschraube Motorblock	bolt, for union	BN4, BN6, BN7, BT7, BJ7	1
M635AH	Dichtung Hohlschraube	washer	BN4, BN6, BN7, BT7, BJ7	2

Motor / Internal Engine BN4, BN6, BN7, BT7, BJ7, BJ8

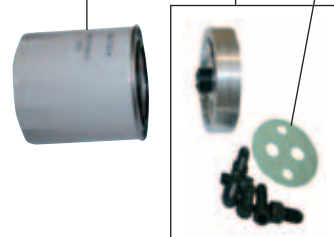
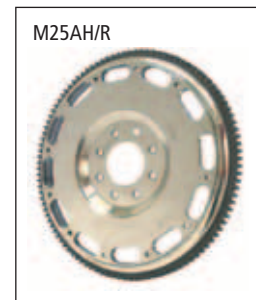
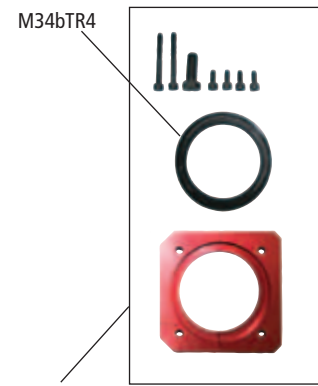
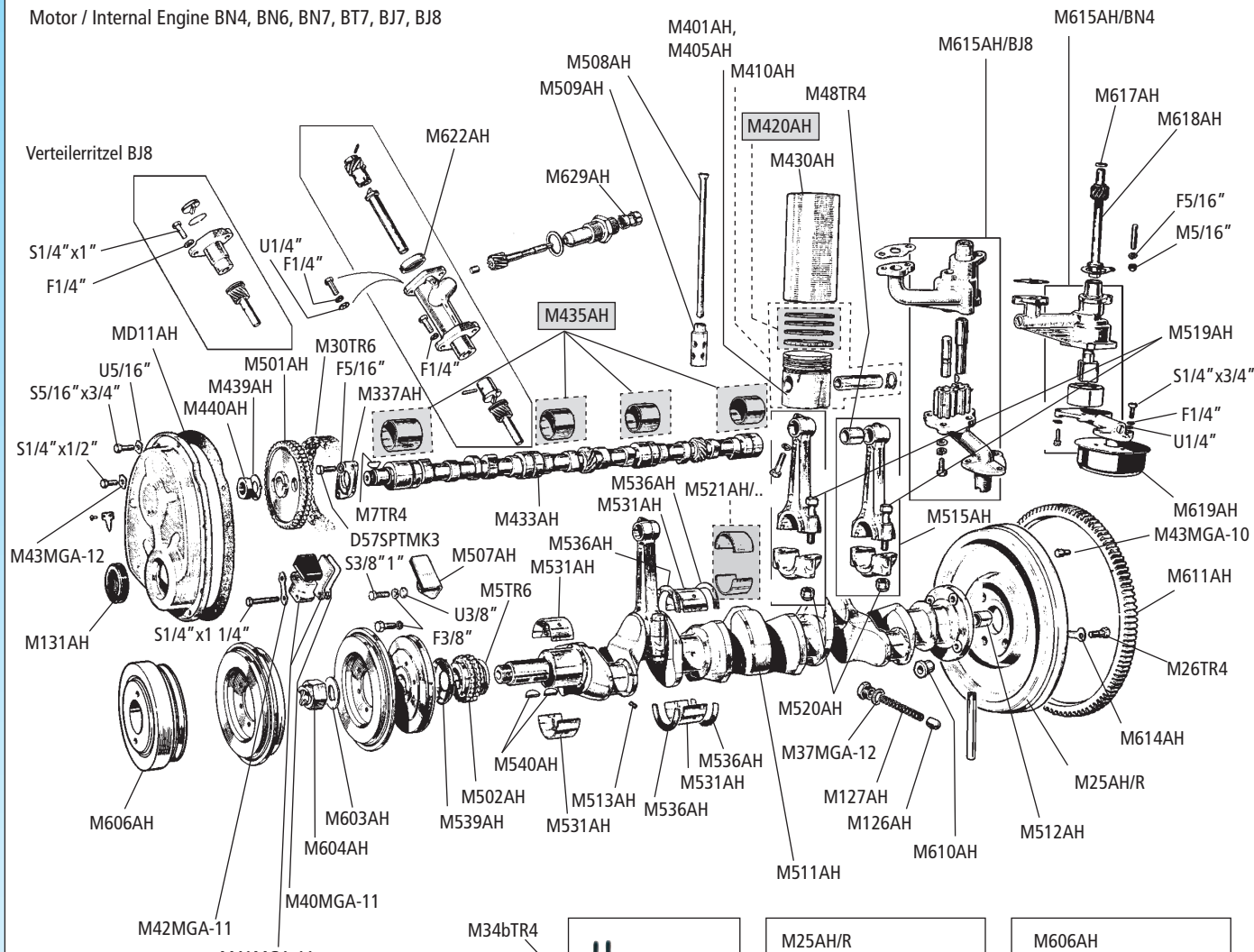

Hinweis: Ölfilter für "Vokes"-Modelle sind nicht mehr lieferbar. Hier muss auf M140AH umgerüstet werden.
Note: "Vokes" type oil filter are no longer available. Conversion to part no. M140AH necessary.

1) 5 Kolbenringe, Kompressionsring 0.094" dick / 5 piston rings, compression ring 0.094" thick
 2) 5 Kolbenringe, Kompressionsring 0.078" dick / 5 piston rings, compression ring 0.078" thick

Motor / Internal Engine BN4, BN6, BN7, BT7, BJ7, BJ8

No.	Bezeichnung	Description	Type	Anzahl/Qty.
M0AH/6-Zyl	AT-Motor mit Zylinderkopf *)	exchange engine *)	BN4, BN6, BN7, BT7, BJ7, BJ8	1
M5TR6	Distanzscheibe Kurbelwelle 0,006"	washer sproket crankshaft 0,006"	BN4, BN6, BN7, BT7, BJ7, BJ8	A/R
M5aTR6	Distanzscheibe Kurbelwelle 0,004"	washer sproket crankshaft 0,004"	BN4, BN6, BN7, BT7, BJ7, BJ8	A/R
M7TR4	Keil Kurbelwelle	key	BN4, BN6, BN7, BT7, BJ7, BJ8	1
MD11AH	Dichtung Steuerkettendeckel	gasket, timing cover	BN4-BJ8	1
MD24AH	Dichtung Ölfiltergehäuse	gasket, oil filter	BN4, BN6, BN7, BT7, BJ7, BJ8	1
M25AH/R	leichte Stahlschwungscheibe	lightweight steel flywheel	BN4-BJ8	1
M26TR4	Befestigungsschraube Schwungscheibe	bolt, flywheel to crankshaft	BN4-BJ8	4
M30TR6	Steuerkette	timing chain	BN4-BJ8	1
M34bTR4	Simmering Motor hinten für Umrüstsatz	replacement seal	BN4-BJ8	1
M37MGA-12	Kupferdichtring 3/4"	washer, copper	BN4-BJ8	1
M40MGA-11	Dichtung Kettenspanner	gasket, tensioner	BN4-BJ8	1
M41MGA-11	Kettenspanner	tensioner assembly, timing chain	BN4, BN6, BN7, BT7, BJ7, BJ8	1
M42MGA-11	Sicherungsblech Kettenspanner	locktab	BN4-BJ8	1
M43MGA-10	Paßstift Kupplungsscheibe	dowel	BN4, BN6, BN7+BT7<29D-H25473	2
M43MGA-12	Flache Scheibe (lang)	washer, oval	BN4-BJ8	5
M48TR4	Pleuelbüchse	bush, connecting rod	BN7, BT7, BJ7, BJ8	6
D57SPTMK3	Schraube 5/16"x7/8" Antriebswelle/Nockenwelle	bolt	BN4, BN6, BN7, BT7, BJ7, BJ8	2
M97VOB18	Einweg-Ölfilter	throw away oil filter	BN4, BN6, BN7, BT7, BJ7, BJ8	1
M97TR4	Ölfilter	oil filter	BN4, BN6, BN7, BT7, BJ7, BJ8	1
M126AH	Überdruckventil Öldruck	oil pressure relief valve	BN4, BN6, BN7, BT7, BJ7, BJ8	1
M127AH	Feder Öldruckventil	spring	BN4, BN6, BN7, BT7, BJ7, BJ8	1
M131AH	Simmerring Steuerdeckel	oil seal, timing cover	BN4, BN6, BN7, BT7, BJ7, BJ8	1
M140AH	Einweg-Ölfilter Adapter	adaptor, throw away oil filter	BN4, BN6, BN7, BT7, BJ7, BJ8	1
M235AH	Umrüstsatz Simmering Motor hinten	rear crankshaft oil seal kit	BN4, BN6, BN7, BT7, BJ7, BJ8	1
M337AH	Führungsplatte Nockenwelle	locating plate	BN4-BJ8	1
M401AH/20	Kolben-Satz 020"	piston set 020"	BN7, BT7, BJ7, BJ8	1
M401AH/30	Kolben-Satz 030"	piston set 030"	BN7, BT7, BJ7, BJ8	1
M401AH/40	Kolben-Satz 040"	piston set 040"	BN7, BT7, BJ7, BJ8	1
M401AH/60	Kolben-Satz 060"	piston set 060"	BN7, BT7, BJ7, BJ8	1
M401AH/STD	Kolben-Satz STD	piston set STD	BN7, BT7, BJ7, BJ8	1
M405AH/20	Kolben-Satz 020" (Kolben mit Sicherungsringen)	piston set 020" (pistons and circlips)	BN4>40501, BN6	1
M405AH/30	Kolben-Satz 030" (Kolben mit Sicherungsringen)	piston set 030" (pistons and circlips)	BN4>40501, BN6	1
M405AH/40	Kolben-Satz 040" (Kolben mit Sicherungsringen)	piston set 040" (pistons and circlips)	BN4>40501, BN6	1
M405AH/60	Kolben-Satz 060" (Kolben mit Sicherungsringen)	piston set 060" (pistons and circlips)	BN4>40501, BN6	1
M405AH/STD	Kolben-Satz STD (Kolben mit Sicherungsringen)	piston set STD (pistons and circlips)	BN4>40501, BN6	1
M410AH	Kolben Satz mit Klemmpleuel - für den nicht mehr lieferbaren Kolbensatz M410AH können die Kolbensätze M405AH/... verwendet werden – hierbei muss der Pleuel M515AH benutzt werden.	piston set - for the no longer available piston set M410AH the piston sets M405AH/. in this connection you have to use the connecting rod M515AH		1
M420AH/BJ7.20	Kolbenringe-Satz 020" für 6 Kolben (5-Ringe) ¹⁾	piston ring set 020" for 6 pistons (5 ring) ¹⁾	BN7, BT7, BJ7, BJ8	1
M420AH/BJ7.30	Kolbenringe-Satz 030" für 6 Kolben (5-Ringe) ¹⁾	piston ring set 030" for 6 pistons (5 ring) ¹⁾	BN7, BT7, BJ7, BJ8	1
M420AH/BJ7.40	Kolbenringe-Satz 040" für 6 Kolben (5-Ringe) ¹⁾	piston ring set 040" for 6 pistons (5 ring) ¹⁾	BN7, BT7, BJ7, BJ8	1
M420AH/BJ7.60	Kolbenringe-Satz 060" für 6 Kolben (5-Ringe) ¹⁾	piston ring set 060" for 6 pistons (5 ring) ¹⁾	BN7, BT7, BJ7, BJ8	1
M420AH/BJ7STD	Kolbenringe-Satz STD für 6 Kolben (5-Ringe) ¹⁾	piston ring set STD for 6 pistons (5 ring) ¹⁾	BN7, BT7, BJ7, BJ8	1
M420AH/BJ8.20	Kolbenringe-Satz 020" für 6 Kolben (5-Ringe) ²⁾	piston ring set 020" for 6 pistons (5 ring) ²⁾	BN7, BT7, BJ7, BJ8	1
M420AH/BJ8.30	Kolbenringe-Satz 030" für 6 Kolben (5-Ringe) ²⁾	piston ring set 030" for 6 pistons (5 ring) ²⁾	BN7, BT7, BJ7, BJ8	1
M420AH/BJ8.40	Kolbenringe-Satz 040" für 6 Kolben (5-Ringe) ²⁾	piston ring set 040" for 6 pistons (5 ring) ²⁾	BN7, BT7, BJ7, BJ8	1
M420AH/BJ8.60	Kolbenringe-Satz 060" für 6 Kolben (5-Ringe) ²⁾	piston ring set 060" for 6 pistons (5 ring) ²⁾	BN7, BT7, BJ7, BJ8	1
M420AH/BJ8STD	Kolbenringe-Satz STD für 6 Kolben (5-Ringe) ²⁾	piston ring set STD for 6 pistons (5 ring) ²⁾	BN7, BT7, BJ7, BJ8	1
M420AH/BN4.20	Kolbenringe-Satz 020" für 6 Kolben (5-Ringe)	piston ring set 020" for 6 pistons (5 ring)	BN4, BN6	1
M420AH/BN4.30	Kolbenringe-Satz 030" für 6 Kolben (5-Ringe)	piston ring set 030" for 6 pistons (5 ring)	BN4, BN6	1
M420AH/BN4.40	Kolbenringe-Satz 040" für 6 Kolben (5-Ringe)	piston ring set 040" for 6 pistons (5 ring)	BN4, BN6	1
M420AH/BN4.60	Kolbenringe-Satz 060" für 6 Kolben (5-Ringe)	piston ring set 060" for 6 pistons (5 ring)	BN4, BN6	1
M420AH/BN4STD	Kolbenringe-Satz STD für 6 Kolben (5-Ringe)	piston ring set STD for 6 pistons (5 ring)	BN4, BN6	1

– Fortsetzung nächste Seite

- to be continued next page

Hinweise
Notes

*) Beachten Sie bitte auch die Hinweise zu den Austauschmotoren auf S. 7 und S. 23 ! / Please refer to our notes on page 7 and 23 !

Motor / Internal Engine BN4, BN6, BN7, BT7, BJ7, BJ8

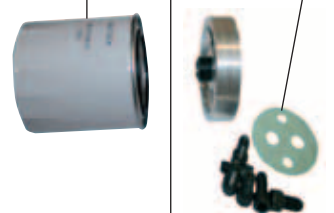
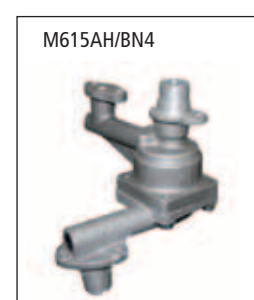
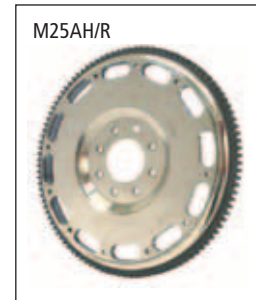
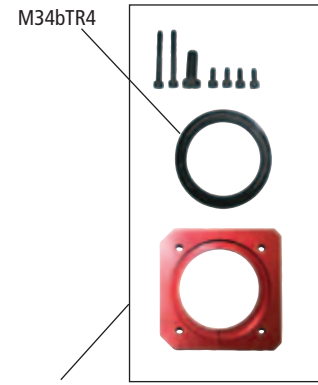
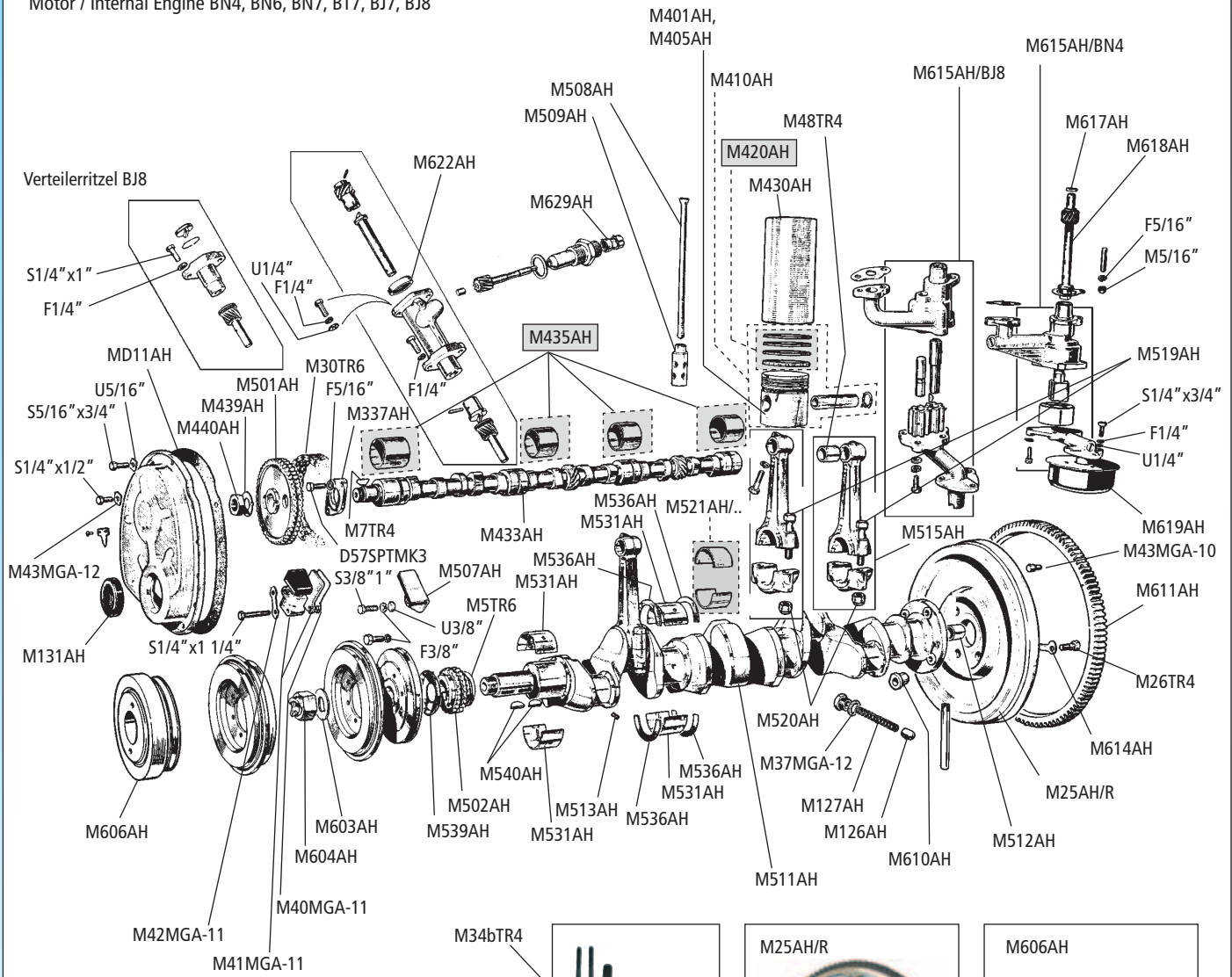

Hinweis: Ölfilter für "Vokes"-Modelle sind nicht mehr lieferbar. Hier muss auf M140AH umgerüstet werden.
Note: "Vokes" type oil filter are no longer available. Conversion to part no. M140AH necessary.

Motor / Internal Engine BN4, BN6, BN7, BT7, BJ7, BJ8

No.	Bezeichnung	Description	Type	Anzahl/Qty.
M430AH	Lauffbuchse	piston liner	BN7, BT7, BJ7, BJ8	6
M430AH/BN4	Lauffbuchse	piston liner	BN4, BN6	6
M433AH	Nockenwelle	camshaft	BN4, BN6, BN7, BT7, BJ7, BJ8	1
M435AH	Nockenwelle-Lager-Satz	cam bearing set	BN4, BN6, BN7, BT7, BJ7, BJ8	1
M439AH	Sicherungsblech Kettenrad Nockenwelle	lock washer	BN4, BN6, BN7, BT7, BJ7, BJ8	1
M440AH	Mutter Kettenrad Nockenwelle	nut	BN4, BN6, BN7, BT7, BJ7, BJ8	1
M501AH	Kettenrad Nockenwelle	camshaft gear	BN4, BN6, BN7, BT7, BJ7, BJ8	1
M502AH	Kettenrad Kurbelwelle	crankshaft gear	BN4, BN6, BN7, BT7, BJ7, BJ8	1
M507AH	Führung Steuerkette	damper chain	BN7&BT7>29E-H101, BJ7, BJ8	1
M508AH	Stößelstange	pushrod	BN4, BN6, BN7, BT7, BJ7, BJ8	12
M509AH	Stößeltasse	tappet	BN4, BN6, BN7, BT7, BJ7, BJ8	12
M511AH	AT-Kurbelwelle	crankshaft, reconditioned	BN4, BN6, BN7, BT7, BJ7, BJ8	1
M512AH	Pilotlager Kurbelwelle	spigot bush	BN4, BN6, BN7, BT7, BJ7, BJ8	1
M513AH	Ölkanal Reduzierung	oil restrictors	BN4-BJ8	6
M515AH	Pleuel aufgearbeitet für Kolben mit Sicherungsringen	connecting rod, for pistons with circlips	BN4>40501, BN6, BN7, BT7, BJ7, BJ8	6
M515AH/BN4A	Pleuel für Kolben 1,3,+ 5 aufgearbeitet	connecting rod, reconditioned for piston 1,3 +5	BN4<40500	3
M515AH/BN4B	Pleuel für Kolben 2,4,+ 6 aufgearbeitet	connecting rod, reconditioned for piston 2,4 +6	BN4<40500	3
M519AH	Pleuelschraube	bolt, con rod cap.	BN4, BN6, BN7, BT7, BJ7, BJ8	12
M520AH	Mutter Pleuelschraube	nut	BN4, BN6, BN7, BT7, BJ7, BJ8	12
M521AH/10	Pleuellager-Satz 0.10"	rod bearing set 0.10"	BN4, BN6, BN7, BT7, BJ7, BJ8	1
M521AH/20	Pleuellager-Satz 0.20"	rod bearing set 0.20"	BN4, BN6, BN7, BT7, BJ7, BJ8	1
M521AH/30	Pleuellager-Satz 0.30"	rod bearing set 0.30"	BN4, BN6, BN7, BT7, BJ7, BJ8	1
M521AH/40	Pleuellager-Satz 0.40"	rod bearing set 0.40"	BN4, BN6, BN7, BT7, BJ7, BJ8	1
M521AH/50	Pleuellager-Satz 0.50"	rod bearing set 0.50"	BN4, BN6, BN7, BT7, BJ7, BJ8	1
M521AH/60	Pleuellager-Satz 0.60"	rod bearing set 0.60"	BN4, BN6, BN7, BT7, BJ7, BJ8	1
M521AH/STD	Pleuellager-Satz STD	rod bearing STD 0.10"	BN4, BN6, BN7, BT7, BJ7, BJ8	1
M531AH/10	Hauptlager-Satz +010"	main bearing set +010"	BN4, BN6, BN7, BT7, BJ7, BJ8	1
M531AH/20	Hauptlager-Satz +020"	main bearing set +020"	BN4, BN6, BN7, BT7, BJ7, BJ8	1
M531AH/30	Hauptlager-Satz +030"	main bearing set +030"	BN4, BN6, BN7, BT7, BJ7, BJ8	1
M531AH/40	Hauptlager-Satz +040"	main bearing set +040"	BN4, BN6, BN7, BT7, BJ7, BJ8	1
M531AH/50	Hauptlager-Satz +050"	main bearing set +050"	BN4, BN6, BN7, BT7, BJ7, BJ8	1
M531AH/60	Hauptlager-Satz +060"	main bearing set +060"	BN4, BN6, BN7, BT7, BJ7, BJ8	1
M531AH/STD	Hauptlager-Satz STD	main bearing set STD	BN4, BN6, BN7, BT7, BJ7, BJ8	1
M536AH/005	Anlaufscheiben-Satz 0.005"	trustwasher set 0.005"	BN4, BN6, BN7, BT7, BJ7, BJ8	1
M536AH/010	Anlaufscheiben-Satz 0.010"	trustwasher set 0.010"	BN4, BN6, BN7, BT7, BJ7, BJ8	1
M536AH/025	Anlaufscheiben-Satz 0.025"	trustwasher set 0.025"	BN4, BN6, BN7, BT7, BJ7, BJ8	1
M536AH/STD	Anlaufscheiben-Satz STD	trustwasher set STD	BN7, BT7, BJ7, BJ8	1
M539AH	Ölschleuderblech	oil thrower	BN4, BN6, BN7, BT7, BJ7, BJ8	1
M540AH	Keil Kurbelwelle	key	BN4, BN6, BN7, BT7, BJ7, BJ8	2
M5TR6	Ausgleichscheibe Kettenrad Kurbelwelle 0.006"	packing washer 0.006"	BN4, BN6, BN7, BT7, BJ7, BJ8	A/R
M5aTR6	Ausgleichscheibe Kettenrad Kurbelwelle 0.004"	packing washer 0.004"	BN4, BN6, BN7, BT7, BJ7, BJ8	A/R
M603AH	Sicherungsblech Kurbelwelle	locktab	BN4, BN6, BN7, BT7, BJ7, BJ8	1
M604AH	Mutter Kettenrad/Kurbelwelle alle 4 + 6 Zylinder Motoren	starting nut all 4 + 6 cyl. models	BN4, BN6, BN7, BT7, BJ7, BJ8	1
M606AH	Keilriemenscheibe 3/8" Riemen incl. Hochleistungs Schwingungsdämpfer	pulley and damper, crankshaft 3/8"	BN4, BN6, BN7, BT7, BJ7, BJ8	1
M610AH	Mutter Schwungscheibenbefestigung	nut	BN4, BN6, BN7, BT7, BJ7, BJ8	4
M611AH	Anlasser-Zahnkranz Schwungscheibe	ring gear	BN4, BN6, BN7, BT7, BJ7, BJ8	1
M614AH	Sicherungsblech Schwungscheibe	locktab	BN4, BN6, BN7, BT7, BJ7, BJ8	2
M615AH/BJ8	Ölpumpe Zahnrad-Pumpe	oil pump assembly	BN7, BT7 ab 29D-H895; BJ7, BJ8 auch für frühe 6 Zyl. möglich / also for early 6 cyl.	1
M615AH/BN4	Ölpumpe Rotor-Pumpe	oil pump assembly (rotors)	BN7, BT7 ab 29D-H895; BJ7, BJ8 auch für späte 6 Zyl. möglich / also for late 6 cyl.	1
M617AH	Anlaufscheibe Ölpumpenantrieb	thrust washer	BN4, BN6, BN7, BT7, BJ7, BJ8	1
M618AH	Antriebswelle Ölpumpe	driving spindle	BN4>38263, BN6, BN7, BT7, BJ7, BJ8	1
M619AH	Filter Ölpumpe	oil strainer	BN4, BN6, BN7, BT7, BJ7, BJ8	1
M620AH	Antriebswelle Verteiler	driving distributor	BN4, BN6, BN7, BT7, BJ7, BJ8	1
M622AH	Öldichtring Verteiler-Antrieb	oil seal, distributor	BN4, BN6, BN7, BT7, BJ7, BJ8	1
M629AH	Öldichtring Drehzahlmesserwelle-Antrieb	oil seal, pinion	BN4, BN6, BN7, BT7, BJ7, BJ8	1

Zylinderkopf / Cylinder Head BN4<48862

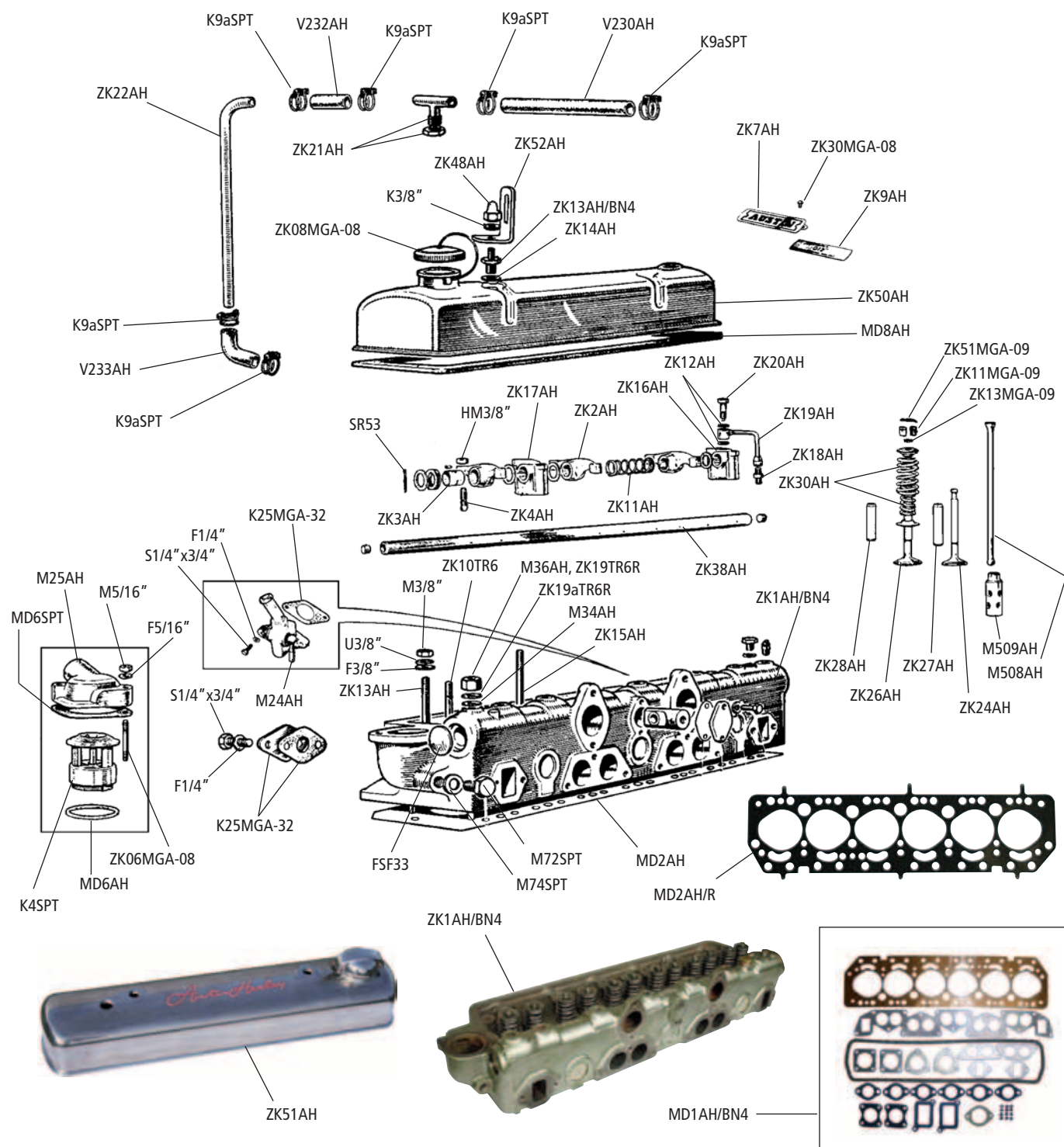

Zylinderkopf / Cylinder Head BN4<48862

No.	Bezeichnung	Description	Type	Anzahl/Qty.
ZK1AH/BN4	AT-Zylinderkopf	cylinder head, exchange	BN4 < CE48862	1
MD1AH/BN4	Zylinderkopf-Dichtsatz mit integrierter Auspuffkrümmer Dichtung	head gasket set (integrated exhaust gasket)	BN4 < CE48862	1
MD2AH	Zylinderkopfdichtung	head gasket	BN4 < CE48862	1
MD2AH/R	Competition Stahl-Zylinderkopfdichtung	head gasket, competition	BN4 < CE48862	1
ZK2AH	Kipphebel	rocker arm, with bush	BN4 < CE48862	12
ZK3AH	Lagerbuchse Kipphebel	bush, rocker arm	BN4 < CE48862	12
ZK4AH	Einstellschraube Ventile	adjuster, rocker arm	BN4 < CE48862	12

Zylinderkopf / Cylinder Head BN4<48862

No.	Bezeichnung	Description	Type	Anzahl/Qty.
K4SPT	Thermostat 74°	thermostate 74°	BN4 < CE48862	1
MD6SPT	Thermostat-Dichtung oben	gasket, thermostate housing	BN4 < CE48862	1
MD6AH	Thermostat-Dichtung unten	gasket, thermostate housing	BN4 < CE48862	1
ZK7AH	Schild „Austin“ auf Ventildeckel	alloy plate, Austin	wenn montiert / as fitted	1
ZK9AH	Schild „Valve clearance 0.12“ hot	brass plate, valve clearance, 0.12“ hot	wenn montiert / as fitted	1
MD8AH	Ventildeckel-Dichtung	gasket, rocker cover	BN4 < CE48862	1
ZK08AMGA-08	Öleinfülldeckel Chrom	oil filler cap, chrome without cable	BN4 < CE48862	1
ZK08MGA-08	Öleinfülldeckel	oil filler cap with cable	BN4 < CE48862	1
K9ASPT	Schlauchschele 16-27mm	clip, hose	BN4 < CE48862	6
ZK10TR6	Stehbolzen Kipphebelwelle	stud, rocker pedestal, short	BN4 < CE48862	4
ZK11AH	Feder zwischen Kipphebel	spring	BN4 < CE48862	5
ZK11MGA-09	Klemmkeil Ventile	cotter, valve retaining	BN4 < CE48862	24
ZK12AH	Dichtscheibe Banjo Schraube	washer	BN4 < CE48862	2
ZK13AH	Stehbolzen Kipphebelwelle lang	stud, rocker pedestal, long	BN4 < CE48862	6
ZK13AH/BN4	Adapter Hutmutter Ventildeckel	adaptor, for nut	BN4 < CE48862	2
ZK13MGA-09	O-Ring Ventilschaft	oil seal, valve stem	BN4 < CE48862	12
ZK14AH	Scheibe Hutmutter Ventildeckel	washer, plain	BN4 < CE48862	2
ZK15AH	Stehbolzen Ventildeckel	stud, rocker pedestal and rocker cover	BN4 < CE48862	2
ZK16AH	Lagerbock Kipphebelwelle mit Gewindeloch	rocker pedestal, with tapped hole	BN4 < CE48862	1
ZK17AH	Lagerbock Kipphebelwelle	rocker pedestal, without tapped hole	BN4 < CE48862	5
ZK18AH	Adapter Kipphebelschmierung	union	BN4 < CE48862	1
ZK19AH	Leitung Öldruck/Kipphebelwelle	oil feed pipe, without union and nut	BN4 < CE48862	1
ZK19ATR6R	U-Scheibe spezial hart 7/16“ parallel geschliffen, ohne Fase	washer plain, high tensile	BN4 < CE48862	16
ZK20AH	Hohlschraube Kipphebelwelle	banjo bolt	BN4 < CE48862	1
ZK21AH	T-Stück Ventildeckel Edelstahl	vent pipe, polished stainless steel	BN4 < CE48862	1
ZK22AH	Motorentlüftung Verbindungsrohr	crankcase vent pipe	BN4 < CE48862	1
M24AH	Heizungsabsperrentil a. Motor	heater control tap	BN4 < CE48862	1
ZK24AH	Ventil Einlass	valve, inlet	BN4 < CE48862	6
K25MGA-32	Dichtung an Zylinderkopf	head gasket	BN4 < CE48862	1
M25AH	Thermostatgehäusedeckel	cap, thermostate housing	BN4 < CE48862	1
ZK26AH	Auslassventil	valve, exhaust	BN4 < CE48862	6
ZK27AH	Ventilführung Einlass	valve guide, inlet	BN4 < CE48862	6
ZK27AH/B	Ventilführung Einlass bronze	valve guide, inlet, manganese-bronze	BN4 < CE48862	6
ZK28AH	Ventilführung Auslass	valve guide, exhaust	BN4 < CE48862	6
ZK28AH/B	Ventilführung Auslass bronze	valve guide, exhaust, manganese-bronze	BN4 < CE48862	6
ZK30AH	Ventilfeder-Satz (24 Federn)	valve spring set (24 spring)	BN4 < CE48862	1
ZK30AH/R	Ventilfeder-Satz hart (12 Federn)	valve spring set, reinforced (12 spring)	BN4 < CE48862	1
ZK30MGA-08	Befestigungsniete	rivet, for plates	BN4 < CE48862	4
ZK32AH	Ventilfeder-Teller oben	cap, valve spring	BN4 < CE48862	12
FSF33	Froststopfen früh 1 5/16“ (33.34 mm)	core plug, dished 1 5/16“	BN4 < CE48862	6
M34AH	Bronze U-Scheibe	washer, bronze	BN4 < CE48862	16
M36AH	Mutter Zylinderkopf	nut, cylinder head stud	BN4 < CE48862	16
ZK38AH	Kipphebelwelle	rocker shaft, with plugs	BN4 < CE48862	1
ZK48AH	Hutmutter Ventildeckel, 2 Einlasskanäle	cap nut	BN4 < CE48862	2
ZK51AH	Ventildeckel Aluminium mit Schriftzug Austin Healey	rocker cover, aluminium with sign „Austin Healey“	BN4 < CE48862	1
ZK51MGA-09	Klammer Ventilkeile	circlip	BN4 < CE48862	12
ZK52AH	Halterung für Motorkran (nur zum Ausbau des Motors)	lifting eye bracket (fit only when lifting engine)	BN4 < CE48862	2
SR53	Splint 2.0 mm	split pin	BN4 < CE48862	2
M72SPT	Ölablaßschraube	plug	BN4 < CE48862	1
M74SPT	Kupferdichtung	washer, copper	BN4 < CE48862	1
V230AH	Entlüftungsschlauch lang/gerade zu Ventildeckel	hose, vent pipe to air cleaner	BN4 < CE48862	1
V232AH	Gerade Gummi-kurz Motorentlüftung	hose	BN4 < CE48862	1
V233AH	Gummi-Bogen Motorentlüftung	elbow, for pipe	BN4 < CE48862	1
M508AH	Stößelstange	pushrod	BN4 < CE48862	12
M509AH	Stößeltasse	tapper	BN4 < CE48862	12
HM3/8“	Mutter 3/8“ UNF halbe Stärke	locknut 3/8“	BN4 < CE48862	12

Auspuffkrümmer / Manifolds BN4<48862

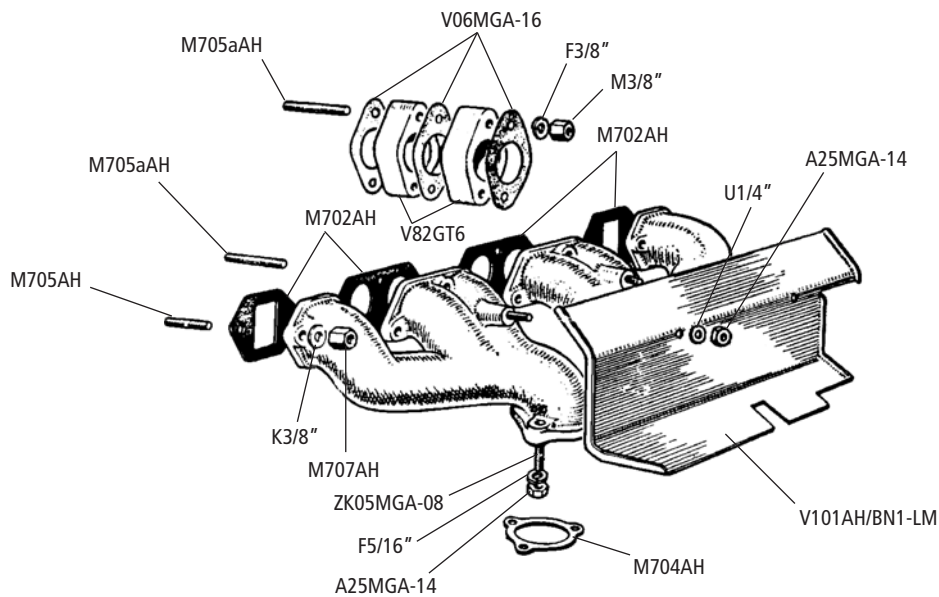

Auspuffkrümmer / Manifolds BN4<48862

No.	Bezeichnung	Description	Type	Anzahl/Qty.
ZK05MGA-08	Krümmer-Stehbolzen „kurz“ außen 5/16" x 15/8" UNF	stud, stock type (short) 5/16" x 15/8" UNF	BN4<48862	6
V06MGA-16	Dichtung Einlaßkrümmer/Vergaser H4	gasket, manifold to carburettor H4	BN4<48862	4/6
A25MGA-14	Auspuff-Krümmer-Mutter 5/16" UNF Messing	nut, brass 5/16" UNF	BN4<48862	A/R
V82GT6	Isolierflansch	insulating block	BN4<48862	A/R
M702AH	Auspuff-Krümmer-Dichtung-Satz (4 Teile)	manifold gasket set (4 pieces)	BN4<48862	1
M704AH	Auspuffrohr-Dichtung	exhaust flange gasket	BN4<48862	2
M705AH	Stehbolzen Krümmer/Zylinderkopf kurz	stud, head to exhaust manifold, short	BN4<48862	8
M705aAH	Stehbolzen Krümmer/Zylinderkopf lang	stud, head to exhaust manifold, long	BN4<48862	A/R
M707AH	Mutter Krümmer/Zylinderkopf Messing (lang) 3/8" UNF	nut, brass (long) 3/8"	BN4<48862	10
V101AH/BN1-LM	Hitzeschild Ansaugkrümmer	heat shield	BN4<48862	1
K3/8"	Karoseriescheibe 3/8"	washer, plain 3/8"	BN4<48862	10

Hinweis 	zu Motorteile	Engine parts
	ab Seite 4	page 4 ff.

Bitte beachten Sie:

Das Altteil 'Motor' ist uns **ohne** folgende Teile anzuliefern:

- | | |
|---------------------------------------|----------------------------|
| - Vergaser und Ansaugstutzen | - Lichtmaschine mit Halter |
| - Einlaß/Auslaßstehbolzen | - Keilriemenscheibe |
| - Auspuffkrümmer | - Stehbolzen Verteiler |
| - Ventildeckel | - Benzinpumpe |
| - Verteilerantrieb | - Stehbolzen Benzinpumpe |
| - Wasserpumpe und Wasserpumpengehäuse | - Ölfiltergehäuse |
| - Thermostatgehäuse | |

Bitte nicht vergessen:

Öl ablassen und Motor vor Anlieferung außen reinigen!

Please obey: The old engines should be sent to us without the following components: :

- | | |
|------------------------------------|-----------------------------------|
| - carburetter and intake manifold, | - thermostat housing, |
| - all manifold studs, | - alternator, |
| - exhaust manifold, | - v-belt disk, |
| - valve cover, | - fuel pump, |
| - distributor and - drive, | - distributor and fuel pump studs |
| - water pump and -housing, | |

Don't forget:

Remove the oil and to clean the housing before delivery.

Hinweis 	zu Getriebe	Gear box
	ab Seite 74	page 74 ff.

Altteile für AT-Getriebe bitte ohne Schalthebel, ohne Ausrückgabel u. -welle, ohne elektr. Schalter und **ohne** Tachoantrieb und in außen gut gereinigtem Zustand anliefern! Overdrive-Altteile bitte **mit** Tachoantrieb in zusammengebautem, kompletten und außen gut gereinigtem Zustand anliefern!

Bitte nicht vergessen: Öl ablassen!

Please supply us your gear box exchange parts without shifting lever, shifting fork and -shaft, w/o electrical switches and **without** tacho drive.

Please supply us your overdrive exchange parts **with** tacho drive.

Don't forget:

Please remove oil and supply exchange parts mounted, complete and cleaned.

Hinweis 	Overdrive und Differential	Overdrive and differential
	ab Seite 82 bzw. 88	page 82 ff. and 88 ff.

Altteile für AT-Differential bitte wie rechts abgebildet in komplettem und gut gereinigtem Zustand anliefern!

Bitte nicht vergessen: Öl ablassen!

Please supply us your differential exchange as shown in figure on the right, complete and cleaned.

Don't forget:

Please remove oil and supply exchange parts mounted, complete and cleaned.

Abb.: AT-Motor / Fig.: Engine, exchange



4 Zylinder / 4 cylinder

6 Zylinder / 6 cylinder

Abb.: AT-Getriebe / Fig.: Gear box, exchange

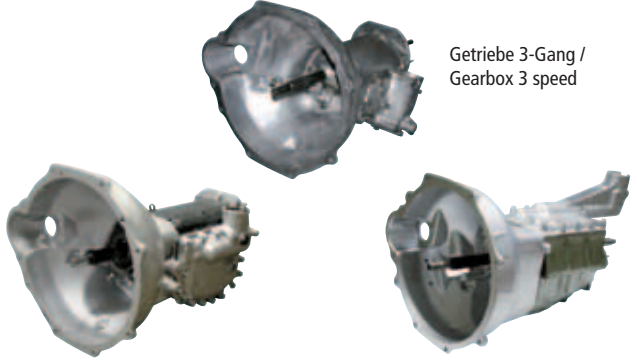

Getriebe 3-Gang / Gearbox 3 speed

Getriebe 4-Gang seitengeschaltet / External Gearbox 4 speed sideshift

Getriebe Mittelschaltung / Gearbox centershift

Abb.: AT-Overdrive / Fig.: Overdrive, exchange



Type A (BN1)

Type A (BN2, BN4, BN6)

Abb.: AT-Differential / Fig.: Differential, exchange



BN1 früh / early model

BN1 spät / late model - BJ8

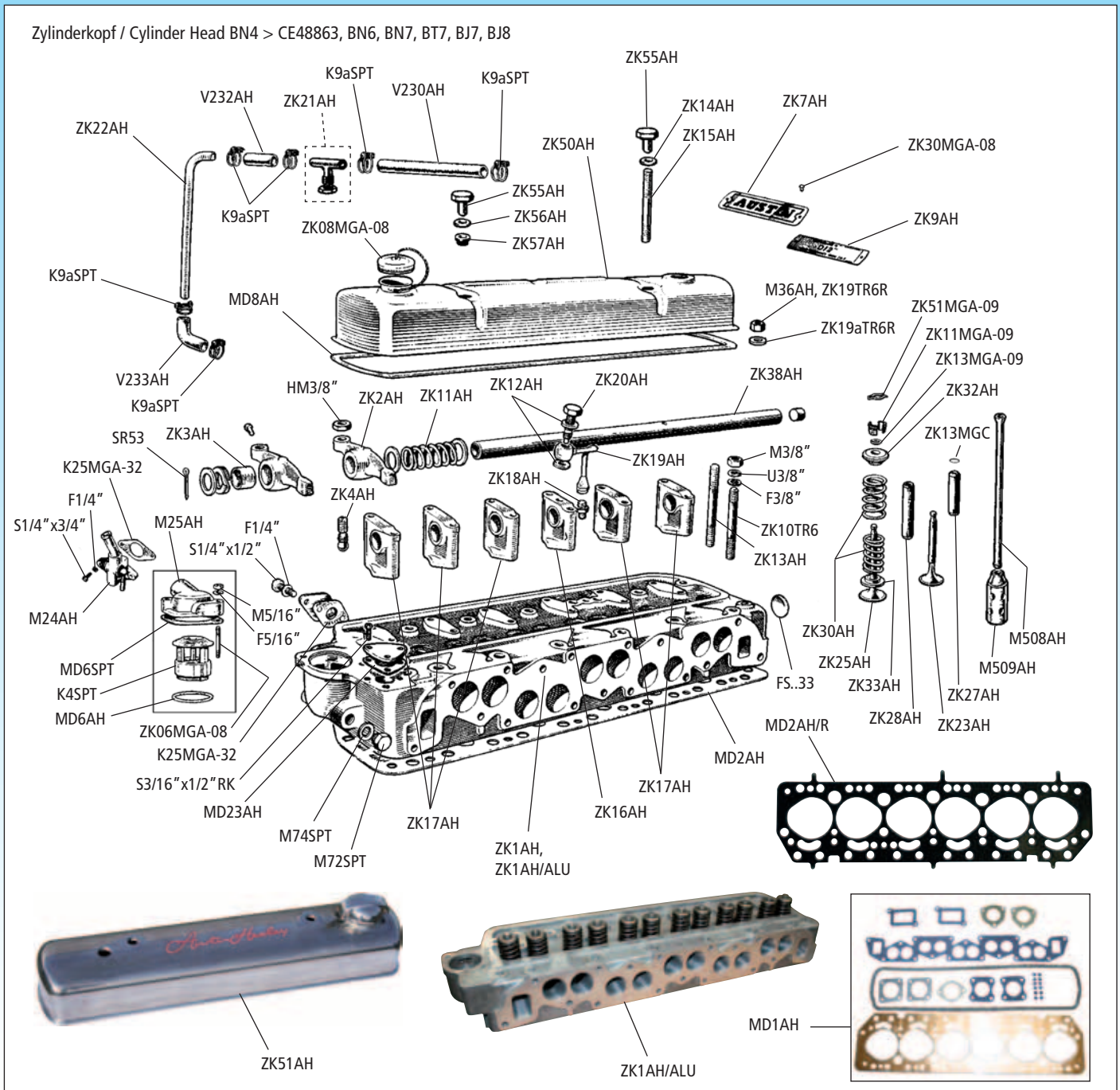

Zylinderkopf / Cylinder Head BN4 > CE48863, BN6, BN7, BT7, BJ7, BJ8

No.	Bezeichnung	Description	Type	Anzahl/Qty.
ZK1AH	AT-Zylinderkopf	cylinder head, exchange	BN4>CE48863-BJ8	1
ZK1AH/ALU	Zylinderkopf Aluminium BN4-BJ8 bleifrei	cylinder head, aluminium	BN4>CE48863-BJ8	1
MD1AH	Zylinderkopf-Dichtsatz	head gasket set	BN4>CE48863-BJ8	1
MD2AH	Zylinderkopf-Dichtung	head gasket	BN4>CE48863-BJ8	1
MD2AH/R	Competition Stahl-Zylinderkopfdichtung	head gasket, competition	BN4>CE48863-BJ8	1
ZK2AH	Kipphebel	rocker arm, with bush	BN4>CE48863-BJ8	12
ZK3AH	Lagerbuchse Kipphebel	bush, rocker arm	BN4>CE48863-BJ8	12
ZK4AH	Einstellschraube Ventile	adjuster, rocker arm	BN4>CE48863-BJ8	12
K4SPT	Thermostat 74°	thermostate 74°	BN4>CE48863-BJ8	1
MD6SPT	Thermostat-Dichtung oben	gasket, thermostate housing	BN4>CE48863-BJ8	1
MD6AH	Thermostat-Dichtung unten	gasket, thermostate housing	BN4>CE48863-BJ8	1
ZK7AH	Schild „Austin“ auf Ventildeckel	alloy plate „Austin“	wenn montiert / as fitted	1
ZK7aAH	Aufkleber „Austin“	mylar decal „Austin“	wenn montiert / as fitted	1
MD8AH	Ventildeckel-Dichtung	gasket, rocker cover	BN4>CE48863-BJ8	1
ZK08MGA-08	Öleinfülldeckel	oil filler cap, with cable	BN4>CE48863-BJ8	1

Zylinderkopf / Cylinder Head BN4 > CE48863, BN6, BN7, BT7, BJ7, BJ8

No.	Bezeichnung	Description	Type	Anzahl/Qty.
ZK08aMGA-08	Öleinfülldeckel Chrom	oil filler cap chrome, without cable	BN4>CE48863-BJ8	1
ZK9AH	Schild Valve clearance 0.12" hot	brass plate, valve clearance 0.12" hot	as fitted	1
ZK9aAH	Aufkleber Valve clearance 0.12" hot	mylar decal, valve clearance 0.12" hot	as fitted	1
K9aSPT	Schlauchschele 16-27mm	clip, hose	BN4>CE48863-BJ8	6
ZK10TR6	Stehbolzen Kipphebelwelle	stud, rocker pedestal, short	BN4>CE48863-BJ8	4
ZK11AH	Feder zwischen Kipphebel	spring	BN4>CE48863-BJ8	5
ZK11MGA-09	Klemmkeil Ventile	cotter, valve retaining	BN4>CE48863-BJ8	24
ZK12AH	Dichtscheibe Banjo Schraube	washer	BN4>CE48863-BJ8	2
ZK13AH	Stehbolzen Kipphebelwelle lang	stud, rocker pedestal, long	BN4>CE48863-BJ8	6
ZK13MGA-09	O-Ring Ventilschaft	oil seal, valve stem	BN4>CE48863-BJ8	12
ZK13MGC	Ventilschaftdichtung	valve stem gasket	BN4>CE48863-BJ8	6
ZK13AH/BN4	Adapter Hutmutter Ventildeckel	adaptor, for nut	BN4>CE48863-BJ8	2
ZK14AH	Scheibe Hutmutter Ventildeckel	washer, plain	BN4>CE48863-BJ8	2
ZK15AH	Stehbolzen Ventildeckel	stud, rocker pedestal and rocker cover	BN4>CE48863-BJ8	2
ZK16AH	Lagerbock Kipphebelwelle mit Gewindeloch	rocker pedestal, with tapped hole	BN4>CE48863-BJ8	1
ZK17AH	Lagerbock Kipphebelwelle	rocker pedestal, without tapped hole	BN4>CE48863-BJ8	5
ZK18AH	Adapter Kipphebelschmierung	union	BN4>CE48863-BJ8	1
ZK19AH	Leitung Öldruck/Kipphebelwelle	oil feed pipe, with union and nut	BN4>CE48863-BJ8	1
ZK19TR6R	Zylinderkopfmutter hochfest	nut, cylinder head reinforced	BN4>CE48863-BJ8	16
ZK19aTR6R	U-Scheibe spezial hart 7/16" parallel geschliffen, ohne Fase	washer, plain	BN4>CE48863-BJ8	16
ZK20AH	Hohlschraube Kipphebelwelle	banjo bolt	BN4>CE48863-BJ8	1
ZK21AH	T-Stück Ventildeckel Edelstahl	vent pipe polished stainless steel	BN4>CE48863-BJ8	1
ZK22AH	Motorentlüftung Verbindungsrohr	crankcase vent pipe	BN4>CE48863-BJ8	1
ZK23AH	Ventil Einlass	inlet valve	BN4>CE48863-BJ8	6
MD23AH	Dichtung Deckel Zylinderkopf Austin Healey	gasket	BN7+ BT7>29D-H2864, BJ7, BJ8	1
M24AH	Heizungsabsperrentil a. Motor	heater control tap	BN4>CE48863-BJ8	1
M25AH	Thermostatgehäusedeckel	cap, thermostate housing	BN4>CE48863-BJ8	1
K25MGA-32	Dichtung an Zylinderkopf MGA/MGB Healey	gasket	BN4>CE48863-BJ8	1
ZK25AH	Auslassventil	exhaust valve	BN4>CE48863-BJ8	6
ZK27AH	Ventilführung Einlass	valve guide, inlet	BN4>CE48863-BJ8	6
ZK27AH/B	Ventilführung Einlass bronze	valve guide, inlet, maganeze-bronze	BN4>CE48863-BJ8	6
ZK28AH	Ventilführung Auslass	valve guide, exhaust	BN4>CE48863-BJ8	6
ZK28AH/B	Ventilführung Auslass bronze	valve guide, exhaust, maganeze-bronze	BN4>CE48863-BJ8	6
ZK30MGA-08	Befestigungsniete	rivet, for plates	as fitted	4
ZK30AH/R	Satz verstärkte Ventilfedern (12 Federn)	valve spring set, reinforced (12 spring)	BN4>CE48863-BJ8	1
ZK30AH	Ventilfeder-Satz (24 Federn)	valve spring set (24 spring)	BN4>CE48863-BJ8	1
ZK32AH	Ventilfeder-Teller oben	cap, valve spring	BN4>CE48863-BJ8	12
ZK33AH	Unterlage Ventilfeder	bottom collar-valve spring	BN4>CE48863-BJ8	12
FSF33	Froststopfen früh 1 5/16" (33.34 mm)	core plug, dished 1 5/16"	BN4>CE48863, BN6	1
FS33	Froststopfen 1 5/16" (33.34 mm)	core plug, cupped 1 5/16"	BN7, BT7, BJ7, BJ8	1
M36AH	Mutter Zylinderkopf	nut, cylinder head stud	BN4>CE48863-BJ8	16
ZK38AH	Kipphebelwelle	rocker shaft, with plugs	BN4>CE48863-BJ8	1
ZK48AH	Hutmutter Ventildeckel, 2 Einlasskanäle	cap nut	BN4>CE48863-BJ8	2
ZK51AH	Ventildeckel Aluminium mit Schriftzug Austin Healey	rocker cover, alloy with sign „Austin Healey“	BN4>CE48863-BJ8	1
ZK51MGA-09	Klammer Ventilkeile	circlip	BN4>CE48863-BJ8	12
ZK52AH	Halterung für Motorkran (nur zum Ausbau des Motors)	lifting eye bracket (fit only when lifting engine)	BN4>CE48863-BJ8	2
SR53	Splint 2.0 mm	split pin	BN4>CE48863-BJ8	2
ZK55AH	Hutmutter Ventildeckel Edelstahl	cap nut	BN4>CE48863-BJ8	2
ZK56AH	Abdeckkappe Edelstahl (Paar)	cup washer, pair (stainless)	BN4-BJ8	1
ZK57AH	Abdeckkappe Gummi Ventildeckel	bush, rubber	BN4>CE48863-BJ8	2
M72SPT	Ölablaßschraube	plug, thermal indicator boss	BN4>CE48863-BJ8	1
M74SPT	Kupferdichtring	washer	BN4>CE48863-BJ8	1
V230AH	Entlüftungsschlauch lang/gerade zu Ventildeckel	hose, vent pipe to air cleaner	BN4>CE48863-BJ8	1
V232AH	Gerade Gummi-kurz Motorentlüftung	hose, vent pipe	BN4>CE48863-BJ8	1
V233AH	Gummi-Bogen Motorentlüftung	elbow, for pipe	BN4>CE48863-BJ8	1
M508AH	Stößelstange	pushrod	BN4>CE48863-BJ8	12
M509AH	Stößeltasse	tappet	BN4>CE48863-BJ8	12
HM3/8"	Mutter 3/8" UNF halbe Stärke	locknut	BN4>CE48863-BJ8	12

Ansaugbrücke, Auspuffkrümmer / Manifolds BN4>48863, BN6, BN7, BT7, BJ7, BJ8

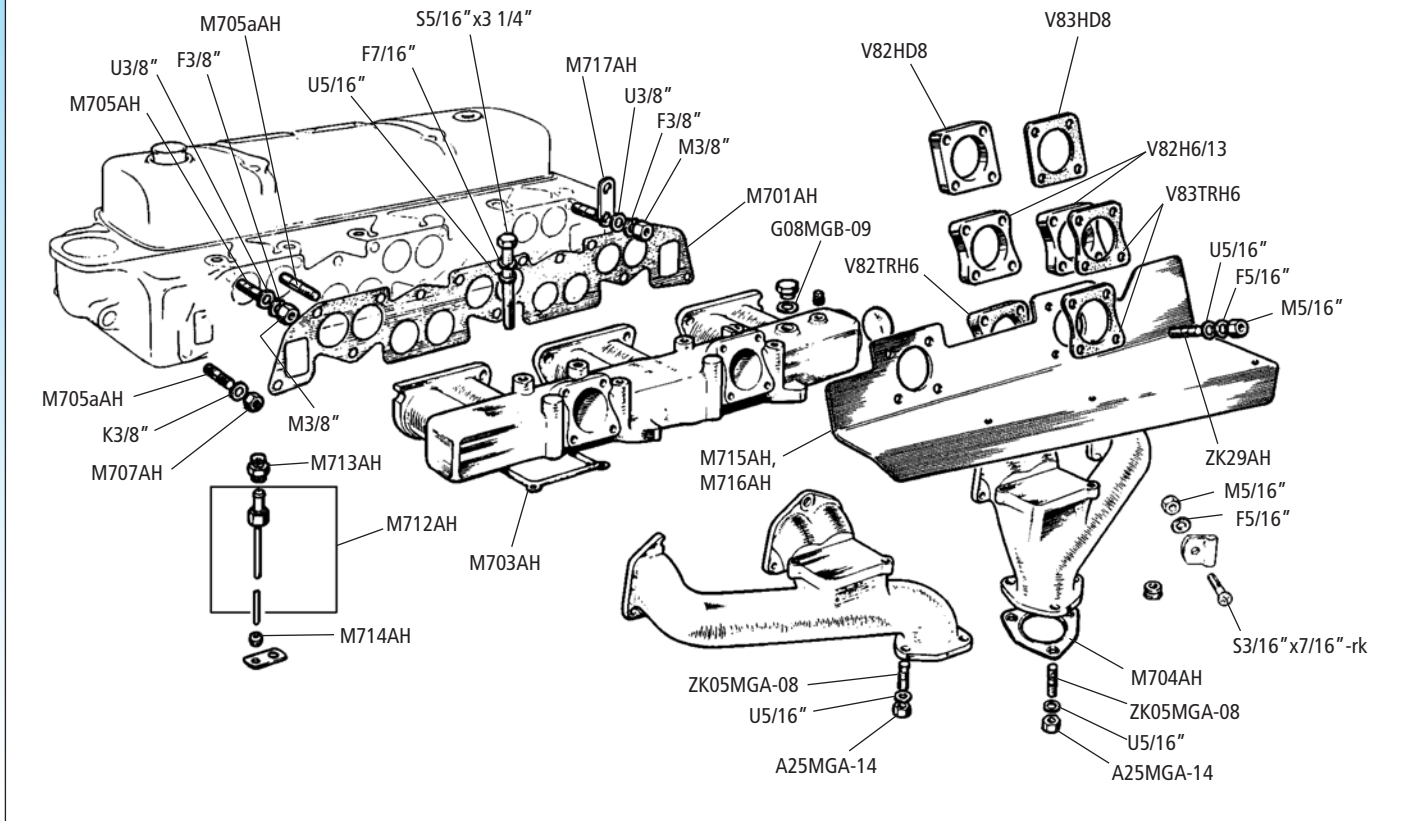

Ansaugbrücke, Auspuffkrümmer / Manifolds BN4>48863, BN6, BN7, BT7, BJ7, BJ8

No.	Bezeichnung	Description	Type	Anzahl/Qty.
ZK05MGA-08	Krümmer-Stehbolzen „kurz“ außen 5/16"x15/8" UNF	stud, stock type (short) 5/16"x15/8" UNF	BN4>48863, BN6, BN7, BT7, BJ7, BJ8	6
G08MGB-09	Fiberscheibe an Schalter auf Getriebedeckel	washer	BN4>48863, BN6, BN7, BT7, BJ7, BJ8	1
A25MGA-14	Auspuff-Krümmer-Mutter 5/16" UNF Messing	nut, brass 5/16" UNF	BN4>48863, BN6, BN7, BT7, BJ7, BJ8	6
ZK29AH	Stehbolzen 5/16 x 2" UNC	stud, manifold to carb. 5/16"x2" UNC	BN4>48863, BN6, BN7, BT7, BJ7, BJ8	8
M701AH	Einlaß-Auslaß Dichtung Zylinderkopf	gasket, manifolds to head	BN4>48863, BN6, BN7, BT7, BJ7, BJ8	1
M703AH	Dichtung Einlass/Auslasskrümmer	gasket, inlet to exhaust manifold	BN4>48863, BN6<66442	4/2
M704AH	Auspuffrohr-Dichtung	exhaust flange gasket	BN4>48863, BN6, BN7, BT7, BJ7, BJ8	2
M705AH	Stehbolzen Krümmer/Zylinderkopf kurz	stud, head to inlet manifold, short	BN4>48863, BN6, BN7, BT7, BJ7, BJ8	A/R
M705aAH	Stehbolzen lang	stud, long	BN4>48863, BN6, BN7, BT7, BJ7, BJ8	A/R
M707AH	Mutter Krümmer/Zylind.kopf Messing (lang) 3/8" UNF	nut, brass (long) 3/8" UNF	BN4>48863, BN6, BN7, BT7, BJ7, BJ8	10
M712AH	Ablaufrohr + Mutter Ansaugkrümmer	pipe assembly, petrol drain	BN4>48863, BN6, BN7, BT7, BJ7, BJ8	2
M713AH	Gewindeadapter	union	BN4>48863, BN6, BN7, BT7, BJ7, BJ8	2
M714AH	Sicherungsclip Benzinleitung	ferrule, for clip	BN4>48863, BN6, BN7, BT7, BJ7, BJ8	2
M715AH	Hitzeschild Vergaser 2"	heat shield 2"	BJ8	1
M716AH	Hitzeschild Vergaser 1 3/4"	heat shield 1 3/4"	BN4>48863, BN6, BN7, BT7, BJ7	1
M717AH	Befestigungsclip Kapillarrohr	clip, thermo capillary pipe	BN6>66673, BN7, BT7, BJ7, BJ8	1
V82TRH6	Isolierflansch	insulating block	BN4>48863, BN6, BN7, BT7	2
V82H6/13	Isolierflansch H6, HS6, HD6 13mm dick	insulating block H6, HS6, HD6 13mm thickn.	BJ7	4
V82HD8	Isolierflansch HD8 Vergaser 2"	insulating block HD8 carb. 2"	BJ8	2
V83TRH6	Dichtung	gasket, heat shield to carb.	BN4>48863, BN6, BN7, BT7, BJ7	A/R
V83HD8	Dichtung Flansch	gasket, heat shield to carb.	BJ8	4
K3/8"	Karoseriescheibe 3/8"	washer, plain 3/8"	BN4>48863, BN6, BN7, BT7, BJ7, BJ8	10

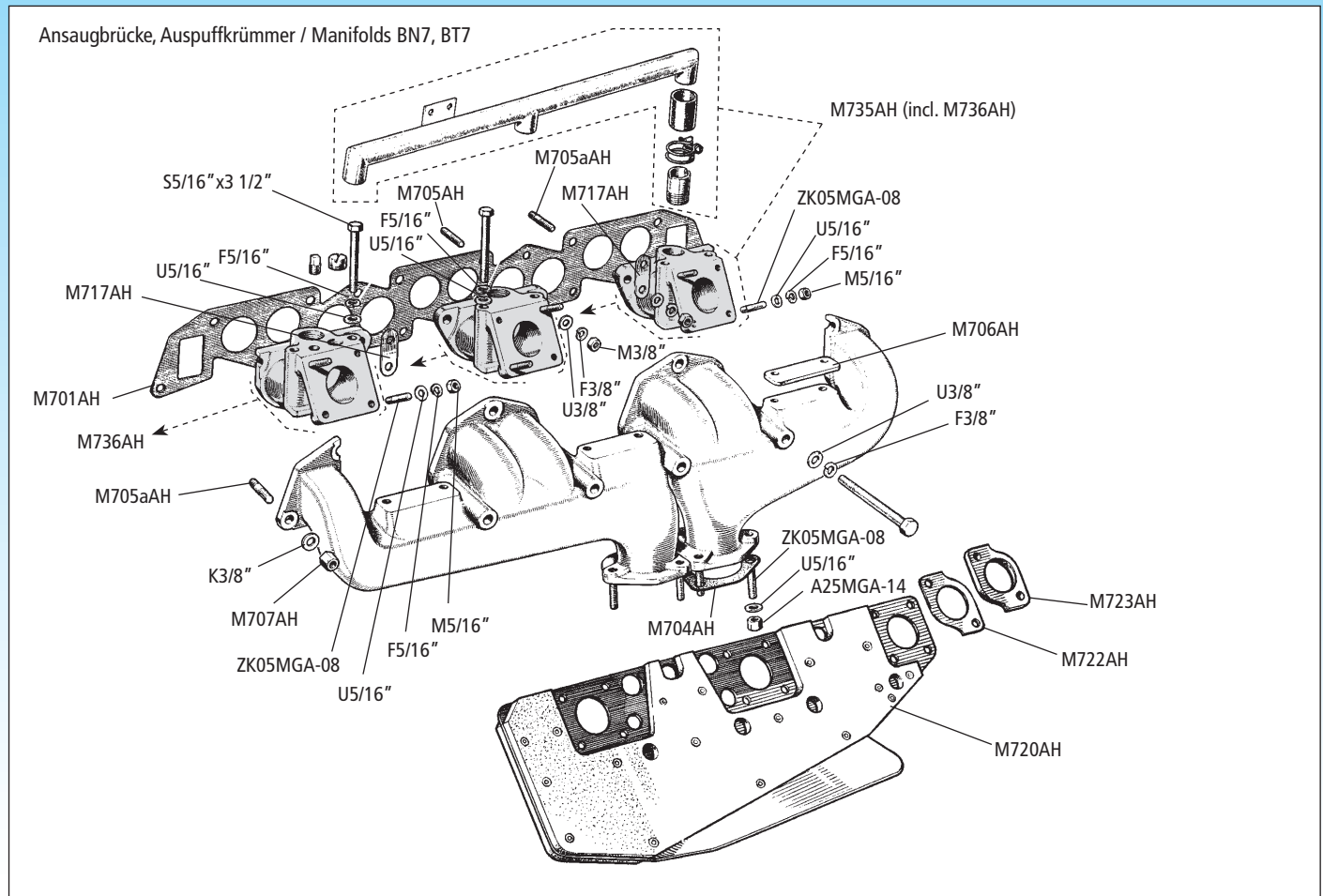

Ansaugbrücke, Auspuffkrümmer / Manifolds BN7, BT7

No.	Bezeichnung	Description	Type	Anzahl/Qty.
ZK05MGA-08	Krümmer-Stehbolzen „kurz“ außen 5/16" x 15/8" UNF	stud, stock type (short) 5/16" x 15/8" UNF	BN7, BT7	A/R
A25MGA-14	Auspuff-Krümmer-Mutter 5/16 UNF Messing	nut, brass 5/16" UNF	BN7, BT7	6
M701AH	Einlaß-Auslaß Dichtung	gasket, manifolds to head	BN7, BT7	1
M704AH	Auspuffrohr-Dichtung	exhaust flange gasket	BN7, BT7	2
M705AH	Stehbolzen Krümmer/Zylinderkopf kurz	stud, head to inlet manifold, short	BN7, BT7	8
M705aAH	Stehbolzen Krümmer/Kopf lang	stud, head to inlet manifold, long	BN7, BT7	9
M706AH	Dichtung Ansaugkrümmer Einlaß	gasket, inlet to exhaust manifold	BN7, BT7	3
M707AH	Mutter Krümmer/Zylinderkopf Messing (lang) 3/8" UNF	nut, brass (long) 3/8" UNF	BN7, BT7	6
M717AH	Befestigungsclip Kapillarrohr	clip, thermo capillary pipe	BN7, BT7	2
M720AH	Hitzeschilder-Satz 3-fach Vergaseranlage	heat shield, triple carb.	BN7, BT7	1
M722AH	Vergaser-Dichtung 3-fach Vergaser	gasket, heat shield	BN7, BT7	A/R
M723AH	Isolierplatte Vergaser 3-fach Vergaser	insulating block	BN7, BT7 > 29E-H929	3
M735AH	Vergaser-Ansaug-Satz 3-fach SU 2"	inlet manifold set (front, center, rear) SU 2"	BN7, BT7 < 29E-H928	1
M736AH	Vergaser-Ansaug-Satz 3-fach SU 2" ohne Ausgleichsschlauch	inlet manifold set (front, center, rear) SU 2" w/o balance pipe	BN7, BT7 < 29E-H928	1
K3/8"	Karoseriescheibe 3/8"	washer, plain 3/8"	BN7, BT7	6



T57..



T98

T120

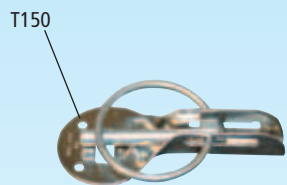

T150

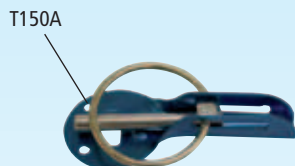

T150A



T151



T152

Rennsportzubehör / Racing Accessories

No.	Bezeichnung
T57b	Aluminium-Pedalauflege Satz, blau
T57r	Aluminium-Pedalauflege Satz, rot
T57s	Aluminium-Pedalauflege Satz, silber
T98b	Textilklebeband blau
T98g	Textilklebeband grün
T98ge	Textilklebeband gelb
T98r	Textilklebeband rot
T98s	Textilklebeband schwarz
T98si	Textilklebeband silber
T98w	Textilklebeband weiss
T100AH	Überrollbügel
T120	Handfeuerlöscher OMP Eco Life, AFFF Gewicht 4,9 kg - Inhalt 2,64 kg
T150	Motorhaubenhalteset
T150A	Motorhaubenhalteset Aluminium
T151	Federhalter mit Haken für Kofferraumdeckel
T152	Hauptstromschalter 6-polig
T160B	Facet Benzinpumpe "Blue Top"
T160R	Facet Benzinpumpe "Red Top"
T160S	Facet Benzinpumpe "Silver Top"
T160-1/4	Anschluß 1/4NPT für T160B und T160R
T160-1/8	Anschluß 1/8NPT für T160S
T161	"Filter King" Druckregler incl. Benzinfilter
T845	Hitzeschutzband 50 mm, Rolle ca. 15 m
T847	Hitzeschutzband 25 mm, Rolle ca. 15 m
T4520/58	Fliegertankdeckel abschließbar, D=58 mm, 6 Befestigungslöcher, für 2"-Anschluß
T4520/76	Fliegertankdeckel abschließbar, D=76 mm, 8 Befestigungslöcher, für 2"-Anschluß
T4521	Anschlußtrichter 2" für Tankdeckel T4520/76
T4522	Schraubenset V2A für Tankdeckel T4520/58 und T4520/76 (8 Schrauben)

Description	Type	Anzahl/Qty.
aluminium pedal plates, blue colors	BN1-BJ8	A/R
aluminium pedal plates, red colors	BN1-BJ8	A/R
aluminium pedal plates, silver colors	BN1-BJ8	A/R
textile tape, blue colors	BN1-BJ8	A/R
textile tape, green colors	BN1-BJ8	A/R
textile tape, yellow colors	BN1-BJ8	A/R
textile tape, red colors	BN1-BJ8	A/R
textile tape, black colors	BN1-BJ8	A/R
textile tape, silver colors	BN1-BJ8	A/R
textile tape, white colors	BN1-BJ8	A/R
roll cage	BN1-BJ8	1
fire extinguisher OMP Eco Life, AFFF Weight: 4,9 kg	BN1-BJ8	1
bonnet holders, set	BN1-BJ8	1
aluminium bonnet holders, set	BN1-BJ8	1
luggage boot holders, spring and hook	BN1-BJ8	1
main current switch, 6- pole	BN1-BJ8	1
fuel pump "Blue Top"	BN1-BJ8	1
fuel pump "Red Top"	BN1-BJ8	1
Fuel pump "Silver Top"	BN1-BJ8	1
connection 1/4NPT for T160B and T160R	BN1-BJ8	1
connection 1/8NPT for T160S	BN1-BJ8	1
fuel pressure regulator "Filter King" with fuel filter	BN1-BJ8	A/R
heat shield tape 50 mm, reel ca. 15 m	BN1-BJ8	A/R
heat shield tape 25 mm, reel ca. 15 m	BN1-BJ8	A/R
aviation tank cap, lockable, Ø 58 mm 6 mounting holes, 2"-fitting	BN1-BJ8	1
aviation tank cap, lockable, Ø 76 mm 8 mounting holes, 2"-fitting	BN1-BJ8	1
funnel 2" suits aviation filler cap T4520/76	BN1-BJ8	1
screw set, inox, for tank caps t4520/58 and T4520/76 (8 Schrauben)	BN1-BJ8	1

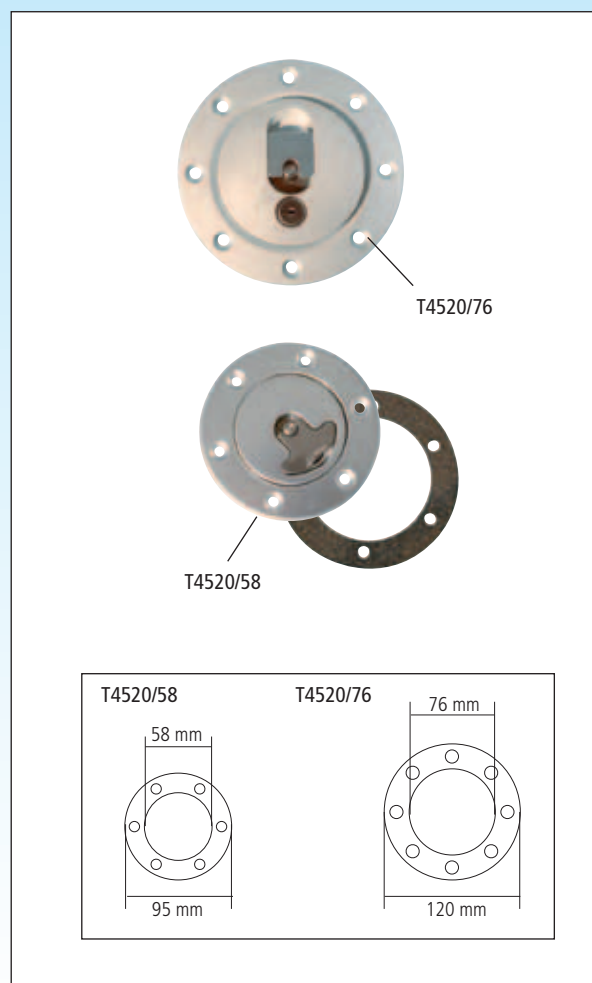
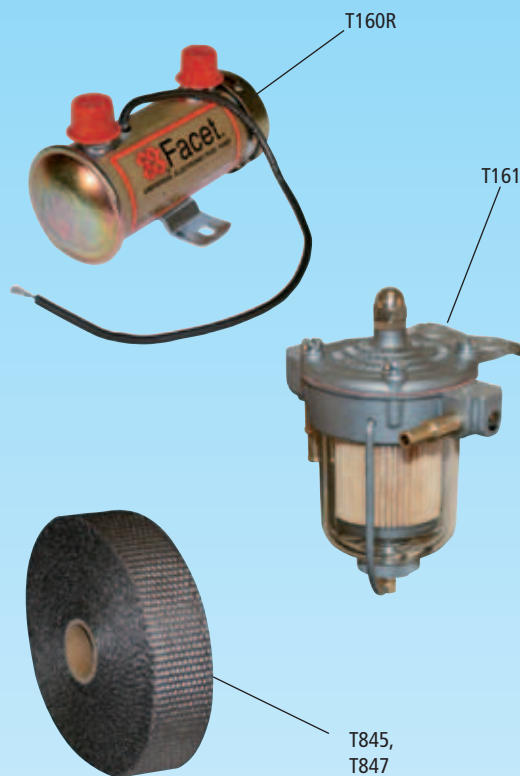

MD2AH/BN1R



M303AH/BN1R



M314AH/BN1R..

M25AH/R

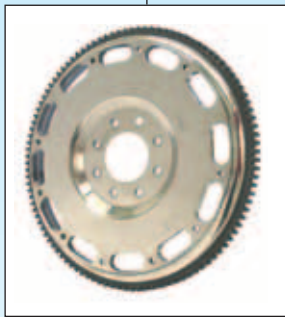

M200AH/BN1..

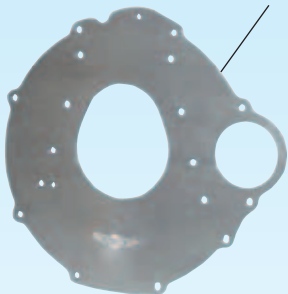

M100AH/BN1

M511AH/BN1/R

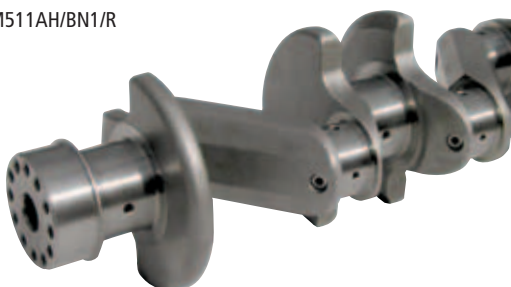

Motortuning / Motor Tuning

No.	Bezeichnung
ZK1AH/BN1-ALU	Zylinderkopf Aluminium
ZK1AH/BN1-AR	Zylinderkopf Aluminium optimierter Brennraum, optimierte Kanäle + größere Ventile
ZK1AH/BN1-FR	Zylinderkopf Aluminium wie ZK1AH/BN1-AR, aber für den Motorsport optimiert
MD2AH/BN1R	Competition Zylinderkopf Dichtung Stahl 3-lagig
ZK17AH/BN1R	Satz Stahl Kipphebelböcke und Distanzrohre
ZK19aTR6R	spezialharte Zylinderkopf Unterlagscheibe
ZK23AH/44.5	44.50mm großes strömungsgünstiges Einlassventil
ZK23AH/46	46.00mm großes strömungsgünstiges Einlassventil
ZK25AH/39.7	39.70mm großes strömungsgünstiges Auslassventil
ZK25AH/41	41.00mm großes strömungsgünstiges Auslassventil
M25AH/R	leichte Stahlschwungscheibe 8-Loch inkl. Anlasserkranz
ZK27AH/BN1-B	Ventilführung Einlass Bronze
ZK28AH/BN1-B	Ventilführung Auslass Bronze
ZK30AH/BN1-HD*	Satz harte doppelte Ventildfedern; für Nockenwellen bis 7,2 mm Nockenhub
ZK30AH/BN1-R*	Satz einfache competition Ventildfedern; für Nockenwellen über 7,2 mm Nockenhub
ZK32AH	Ventilfeder-Teller oben für ZK30AH/BN1-HD / ZK30AH/BN1-R
M35AH/BN1R	Satz hochfeste Stehbolzen + Muttern Zylinderkopf
ZK38AH/BN1R	rollengelagerte Kipphebelwelle
ZK51AH/BN1	Ventildeckel Alu mit Schriftzug poliert
M100AH/BN1	Aluminium Ölwanne
M200AH/BN1	Motorplatte hinten Aluminium
M200AH/BN1S	Motorplatte hinten Aluminium für BN4-Getriebeglocke
M220AH/BN1-R	Rohrstößelstange verstärkt
M221AH/BN1R	optimierte Stößelbecher mit zusätzlicher Ölbohrung
M303AH/BN1R	Satz flache Schmiedekolben Verdichtung 10,5:1 88 mm Bohrung
M314AH/BN1R	Satz Sportpleuel 100/S Type für STD Kurbelwelle
M314AH/BN1R-K	Satz Sportpleuel für Stahlkurbelwelle
M501AH/R	Einstellbares Kettenrad Nockenwelle
M511AH/BN1R	Stahlkurbelwelle mit 8-Loch Schwungscheibenbefestigung

Nockenwelle / Camshaft

M280AH/BN1	280° Sportnockenwelle, 37/67-73/27 Steuerzeit, 7,15mm Nockenhub – beste Nockenwelle für Straßensportfahrzeuge
M290AH/BN1	290° Sportnockenwelle, 42/73-78/32 Steuerzeit, 7,84 mm Nockenhub – geeignet für gut getunte Fahrzeuge + Rallye
M300AH/BN1	300° Sportnockenwelle, 47/73-83/37 Steuerzeit, 8,22mm Nockenhub – Rundstreckennockenwelle
M338AH/BN1-LM	Nockenwelle „Le-Mans“, 24/64-59/29 Steuerzeiten, Nockenhub 6,40 mm (0.252")

* zur Montage werden ZK32AH Ventilteller benötigt!

Description	Type	Anzahl/Qty.
aluminum cylinder head	BN1, BN2	1
fast road 4 cyl. aluminum head optimized combustion chamber, channels + high valve	BN1, BN2	1
full race 4 cyl. aluminum head, the same as ZK1AH/BN1-AR, but optimized for motorsport	BN1, BN2	1
competition steel head gasket 3 layer	BN1, BN2	1
steel rocker pedestal & spacer set	BN1, BN2	1
washer 7/16" , high tensile	BN1, BN2	11
inlet valve std size - comp. (44.5 mm)	BN1, BN2	4
inlet valve large - comp. (46 mm)	BN1, BN2	4
exhaust valve std. comp. (39.7 mm)	BN1, BN2	4
exhaust valve large - comp. (41 mm)	BN1, BN2	4
steel flywheel 8ORG holes	BN1, BN2	1
valve guide inlet bronze	BN1, BN2	4
valve guide outlet bronze	BN1, BN2	4
heavy duty valve springs 4 cyl., for camshaft to 7,2 mm stroke	BN1, BN2	1
valve spring set - competition, for camshaft from 7,2 mm stroke	BN1, BN2	1
valve-cap for ZK30AH/BN1-HD / ZK30AH/BN1-R	BN1, BN2	8
competition head studs & nuts cyl. head	BN1, BN2	1
roller rocker kit	BN1, BN2	1
valve cap alu polished	BN1, BN2	1
alu oil pan	BN1, BN2	1
aluminium back plate	BN1, BN2	1
aluminium back plate to suit BN4 bellhousing	BN1, BN2	1
valve push rod	BN1, BN2	8
cam followers - modified	BN1, BN2	8
pistons 10,5:1 / 88 mm	BN1, BN2	1
steel con rod 100/s type	BN1, BN2	1
steel rod set-for steel crank	BN1, BN2	1
adjustable timing gear camshaft	BN1, BN2	1
steel crankshaft	BN1, BN2	1
280° hight performance camshaft, timing: 37/67-73/27 stroke: 7,15mm – for road engines	BN1, BN2	1
290° hight performance camshaft timing: 42/73-78/32 stroke: 7,84 mm – for good optimized engines + competition	BN1, BN2	1
300° hight performance camshaft, timing: 47/73-83/37, stroke: 8,22mm cam lift – for round courses	BN1, BN2	1
camshaft „Le-Mans“, timing: 24/64-59/29, stroke: 6,40 mm (0.252")	BN1, BN2	1

* for mounting you need ZK32AH valve-cap





Motortuning / Motor Tuning

No.	Bezeichnung
ZK1AH/ALU	Zylinderkopf Aluminium
ZK1AH/AR	Zylinderkopf Aluminium optimierter Brennraum, optimierte Kanäle + größere Ventile
ZK1AH/FR	Zylinderkopf Aluminium wie ZK1AH/AR aber für Motorsport optimiert
M15SPTMK3R	Befestigungsschraube hochfest Schwungscheibe für Sportzwecke
ZK17AH/R	Satz Stahl Kipphebelböcke + Distanzrohre
ZK19TR6R	Zylinderkopfmutter hochfest
ZK19aTR6R	U-Scheibe spezial hart
ZK23AH/44.5	Ventil Einlass Ø 44.5mm Competition
ZK23AH/46	Ventil Einlass Ø 46mm Competition
ZK25AH/39.7	Ventil Auslass Ø 39.7mm Competition
ZK25AH/41	Ventil Auslass Ø 41.0mm Competition
M25AH/R	leichte Stahlschwungscheibe 8-Loch incl. Anlasserkranz
ZK27AH/B	Ventilführung Einlass Bronze
ZK28AH/B	Ventilführung Auslass Bronze
ZK30AH/HD	Satz harte doppelte Ventildfedern für Nockenwelle bis 7,2 mm Nockenhub
ZK30AH/R	Satz einfache competition Ventildfedern für Nockenwelle über 7,2 mm Nockenhub
ZK30AH/.010"	0.010"/0.25 mm Ausgleichsscheibe Ventildfedern Außen-Ø 15,09 mm
ZK30AH/.010"L	0.010"/0.25 mm Ausgleichsscheibe Ventildfedern Außen-Ø 16,26 mm
ZK30AH/.015"	0.015"/0.38 mm Ausgleichsscheibe Ventildfedern Außen-Ø 15,09 mm
ZK30AH/.020"	0.020"/0.51 mm Ausgleichsscheibe Ventildfedern Außen-Ø 15,09 mm
M35AH/R	Satz hochfeste Stehbolzen + U-Scheiben + Muttern für Zylinderkopf
ZK30TR4	Tassen Stößelbecher mit Zusatzbohrung
ZK38AH/R	rollengelagerte Kipphebelwelle Übersetzung 1.65:1
M41AH/R	verstärkter hydraulischer Kettenspanner
M45AH/R	Satz hochfeste Stehbolzen Hauptlagerdeckel
M48AH	Aluminium Motorplatte hinten
M48AH/R*	Aluminium Motorplatte hinten für Fahrzeuge mit M511AH/R Kurbelwelle
ZK51AH	Aluminium-Ventildeckel mit Schriftzug (poliert)
M100AH	Aluminium Ölwanne
M401AH/83,5	Satz 83,5 mm Sportkolben (6)
M401AH/84,0	Satz 84,0 mm Sportkolben (6)
M401AH/85,0	Satz 85,0 mm Sportkolben (6)
M501AH/R	einstellbares Kettenrad Nockenwelle
M508AH/R	Satz (12) Rohrstößelstangen verstärkt für ZK30TR4
M511AH/R*	Stahl Kurbelwelle 8-Loch Schwungscheibenbefestigung
M515AH/R	Sportpleuel
M515AH/R-SK*	Satz Stahlpleuel für M511AH/R Stahl Kurbelwelle
M521AH/R-STD*	Pleuellager-Satz STD für M511AH/R
Nockenwelle / Camshaft	
M280AH	280° AT-Sportnockenwelle 37/67-73/27, Steuerzeit 7,15 mm Nockenhub – beste Nockenwelle für Straßenfahrzeuge
M290AH	290° AT-Sportnockenwelle 42/73-78/32, Steuerzeit 7,84 mm Nockenhub – geeignet für gut getunte Fahrzeuge + Rallye
M300AH	300° AT-Sportnockenwelle 47/73-83/37, Steuerzeit 8,22 mm Nockenhub – Rundstreckennockenwelle

* M511AH/R ; M515AH/R-SK ; M48AH/R ; M521AH/R-STD sind nur gemeinsam zu verwenden

Description	Type	Anzahl/Qty.
aluminum cylinder head	BN4 > CE48863-BJ8	1
fast road aluminum 4 cyl. head optimized combustion chamber, channels + high valve	BN4 > CE48863-BJ8	1
full race 4 cyl. Ali. Head the same as ZK1AH/AR but optimized for motorsport	BN4 > CE48863-BJ8	1
flywheel bolts	BN4-BJ8	4
steel rocker pedestal & spacer set	BN4,BN6,BN7,BT7,BJ7,BJ8	1
uprated cylinder head nut	BN4,BN6,BN7,BT7,BJ7,BJ8	16
washer , high tensile	BN4,BN6,BN7,BT7,BJ7,BJ8	16
valve inlet Ø 44.5mm competition	BN4,BN6,BN7,BT7,BJ7,BJ8	6
valve inlet Ø 46 mm competition	BN4,BN6,BN7,BT7,BJ7,BJ8	6
valve outlet Ø 39.7 mm competition	BN4,BN6,BN7,BT7,BJ7,BJ8	6
valve outlet Ø 41.0 mm competition	BN4,BN6,BN7,BT7,BJ7,BJ8	6
steel flywheel 8ORG holes	BN4,BN6,BN7,BT7,BJ7,BJ8	1
valve guide inlet bronze	BN4,BN6,BN7,BT7,BJ7,BJ8	6
valve guide outlet bronze	BN4,BN6,BN7,BT7,BJ7,BJ8	6
heavy duty valve springs ; for camshaft to 7,2mm stroke	BN4,BN6,BN7,BT7,BJ7,BJ8	1
valve spring set - comp; for camshaft from 7,2 mm stroke	BN4,BN6,BN7,BT7,BJ7,BJ8	1
valve spring shim 0.010"/0.25 mm outer-Ø 15,09 mm	BN4,BN6,BN7,BT7,BJ7,BJ8	A/R
valve spring shim 0.010"/0.25 mm outer-Ø 16,26 mm	BN4,BN6,BN7,BT7,BJ7,BJ8	A/R
valve spring shim 0.015"/0.38 mm outer-Ø 15,09 mm	BN4,BN6,BN7,BT7,BJ7,BJ8	A/R
valve spring shim 0.020"/0.51 mm outer-Ø 15,09 mm	BN4,BN6,BN7,BT7,BJ7,BJ8	A/R
set competition head studs & nuts & washers	BN4 ab CE48863-BJ8	1
bucket cam followers - modified	BN4-BJ8	12
roller rocker kit	BN4-BJ8	1
hydraulic tensioner	BN4-BJ8	1
main stud STD	BN4-BJ8	1
aluminium back plate	BN4-BJ8	1
aluminium back plate for cars with M511AH/R crankshaft	BN4-BJ8	1
valve cap alu polished	BN4-BJ8	1
alu oil pan	BN4-BJ8	1
racing pistons set 83,5mm (6)	BN4-BJ8	1
racing pistons set 84,0mm (6)	BN4-BJ8	1
racing pistons set 85,0mm (6)	BN4-BJ8	1
vernier cam sprocket	BN4-BJ8	1
long push rod set - bucket for ZK30TR4	BN4-BJ8	1
steel crankshaft	BN4-BJ8	1
con rod for competition	BN4>40501-BJ8	6
steel con rod set for M511AH/R	BN4-BJ8	1
big end set (std) steel crank	BN4-BJ8	1
280° high performance camshaft, exchange timing: 37/67-73/27 stroke: 7,15 mm – for road engines	BN4-BJ8	1
290° high performance camshaft, exchange timing: 42/73-78/32 stroke: 7,84 mm – for good optimized engines + competition	BN4-BJ8	1
300° high performance camshaft, exchange timing: 47/73-83/37 stroke: 8,22 mm cam lift – for round courses	BN4-BJ8	1

* M511AH/R ; M515AH/R-SK ; M48AH/R ; M521AH/R-STD only use together

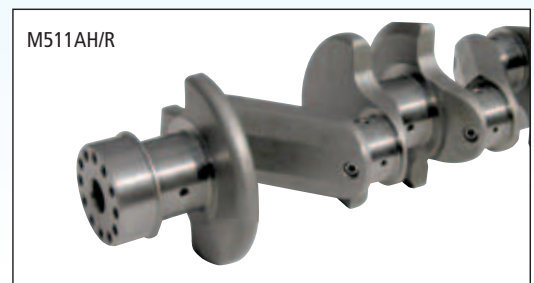
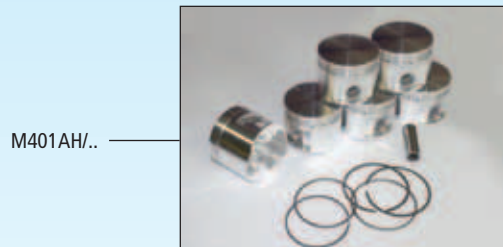
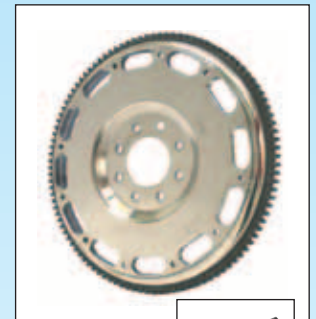
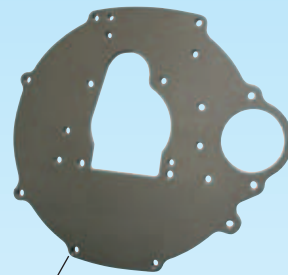

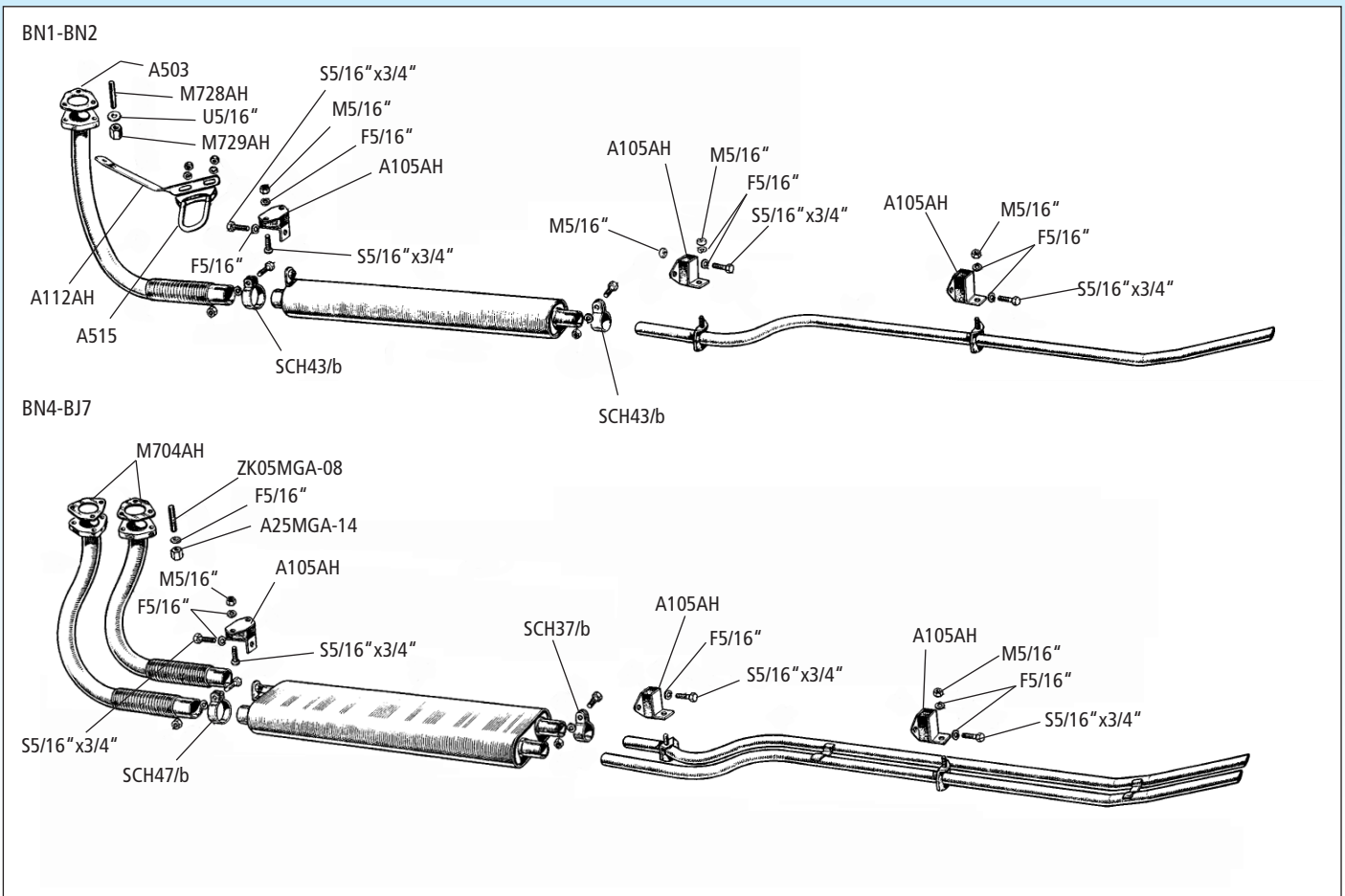
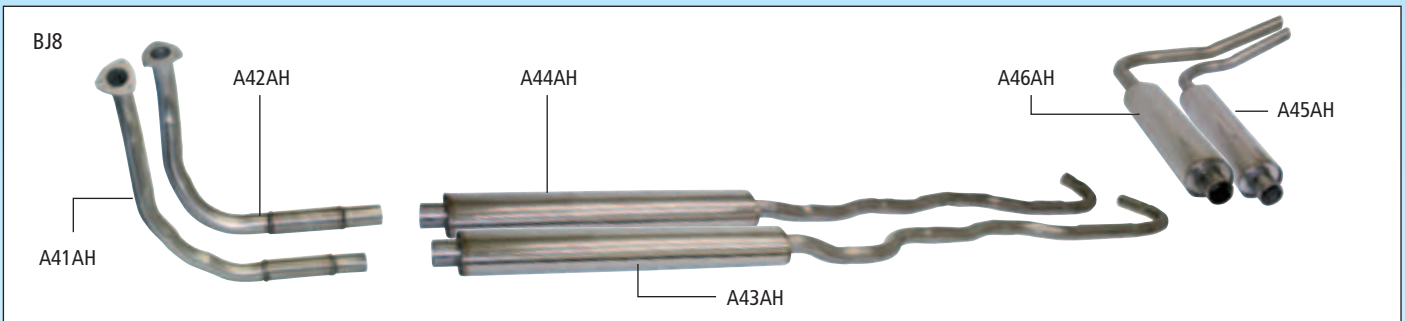
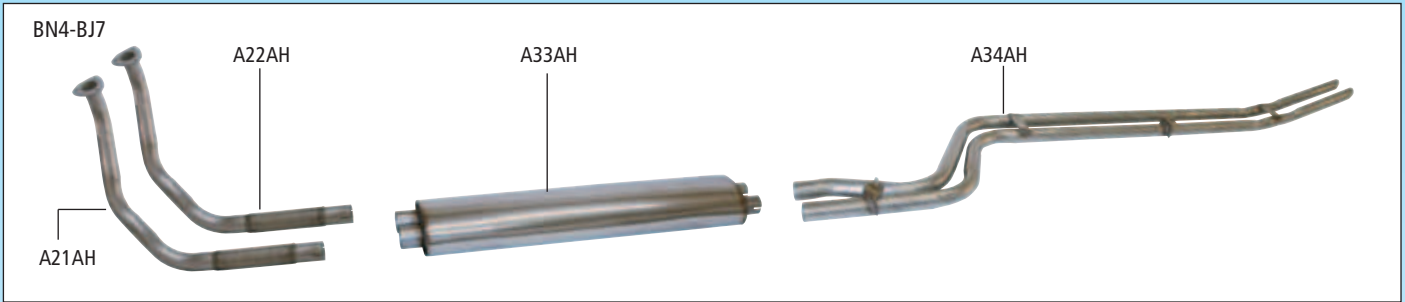
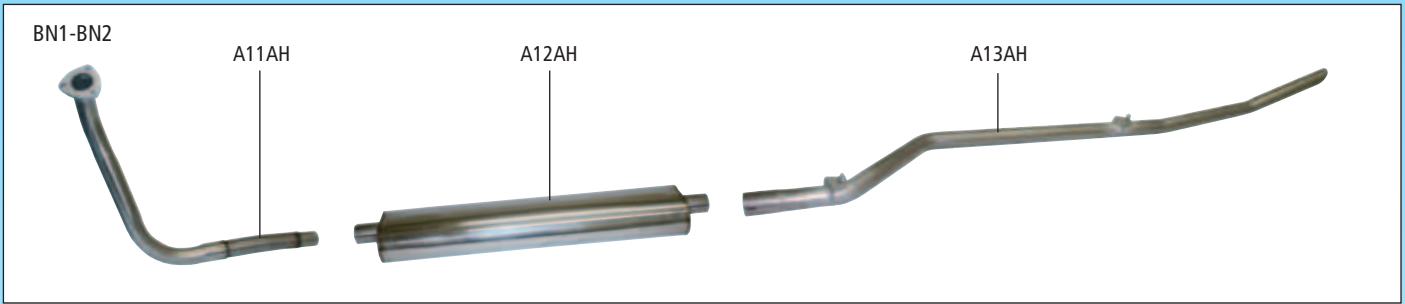

No.	Bezeichnung	Description	Type	Anzahl/Qty.
BN1-BN2				
A11AH	Auspuffrohr vorne	front exhaust pipe	BN1-BN2	1
A12AH	Schalldämpfer	silencer	BN1-BN2	1
A13AH	Endrohr	tail pipe	BN1-BN2	1
SCH43/b	Auspuffschelle Edelstahl	exhaust clamp, stainless steel	BN1-BN2	2
A105AH	Gummi Auspuff-Halterung	rubber exhaust mounting	BN1-BJ7, BJ8	3
A112AH	Auspuffhalter vorne	bracket front pipe	BN1-BN2	1
A503	Dichtung Auspuffrohr	gasket exhaust pipe	BN1-BN2	1
A515	Auspuffschelle	clamp pipe to bracket	BN1-BN2	1
M728AH	Stehbolzen Auspuffrohr vorne	stud manifold>front exhaust pipe	BN1-BN2	3
M729AH	Mutter Auspuffrohr vorne	nut front exhaust pipe	BN1-BN2	6
BN4-BJ7				
ZK05MGA-08	Stehbolzen Auspuffrohr vorne	stud manifold>front exhaust pipe	BN4-BJ8	6
A21AH	Auspuffrohr vorne links	front exhaust pipe left	BN4-BJ7	1
A22AH	Auspuffrohr vorne rechts	front exhaust pipe right	BN4-BJ7	1
A25MGA-14	Mutter Auspuffrohr vorne	nut front exhaust pipe	BN4-BJ8	6
A33AH	Schalldämpfer	silencer	BN4-BJ7	1
A34AH	Endrohr	tail pipe	BN4-BJ7	1
SCH37/b	Auspuffschelle Edelstahl	exhaust clamp, stainless steel	BN4-BJ7	2
SCH47/b	Auspuffschelle Edelstahl	exhaust clamp, stainless steel	BN4-BJ7	2
A105AH	Gummi Auspuff-Halterung	rubber exhaust mounting	BN1-BJ7	3
M704AH	Dichtung Auspuffrohr	gasket exhaust pipe	BN4-BJ8	2
BJ8				
ZK05MGA-08	Stehbolzen Auspuffrohr vorne	stud manifold>front exhaust pipe	BJ8	6
A25MGA-14	Mutter Auspuffrohr vorne	nut front exhaust pipe	BJ8	6
A41AH	Auspuffrohr vorne links	front exhaust pipe left	BJ8	1
A42AH	Auspuffrohr vorne rechts	front exhaust pipe right	BJ8	1
A43AH	Schalldämpfer vorne links	front silencer left	BJ8	1
A44AH	Schalldämpfer vorne rechts	front silencer right	BJ8	1
A45AH	Schalldämpfer hinten außen	rear silencer, outer	BJ8	1
A46AH	Schalldämpfer hinten innen	rear silencer, inner	BJ8	1
SCH43/b	Auspuffschelle Edelstahl	exhaust clamp, stainless steel	BJ8	2
SCH47/b	Auspuffschelle Edelstahl	exhaust clamp, stainless steel	BJ8	4
A106aAH	Satz Auspuff-Aufhängungen vorne	exhaust mounting kit front	BJ8	1
A107aAH	Satz Auspuff-Aufhängungen Mitte	exhaust mounting kit intermediate	BJ8	1
A108aAH	Satz Auspuff-Aufhängungen hinten	exhaust mounting kit rear	BJ8	1
A105AH	Gummi Auspuff-Halterung	rubber exhaust mounting	BJ8	5
M704AH	Dichtung Auspuffrohr	gasket exhaust pipe	BN4-BJ8	2

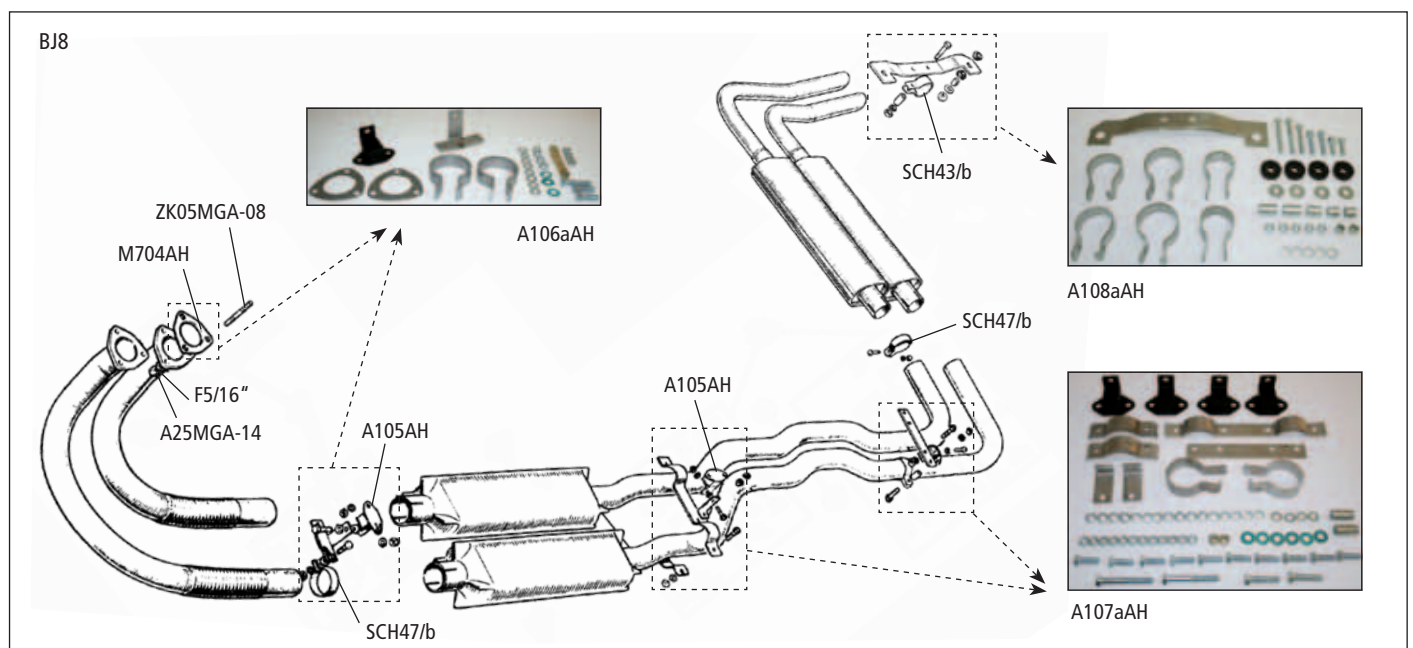

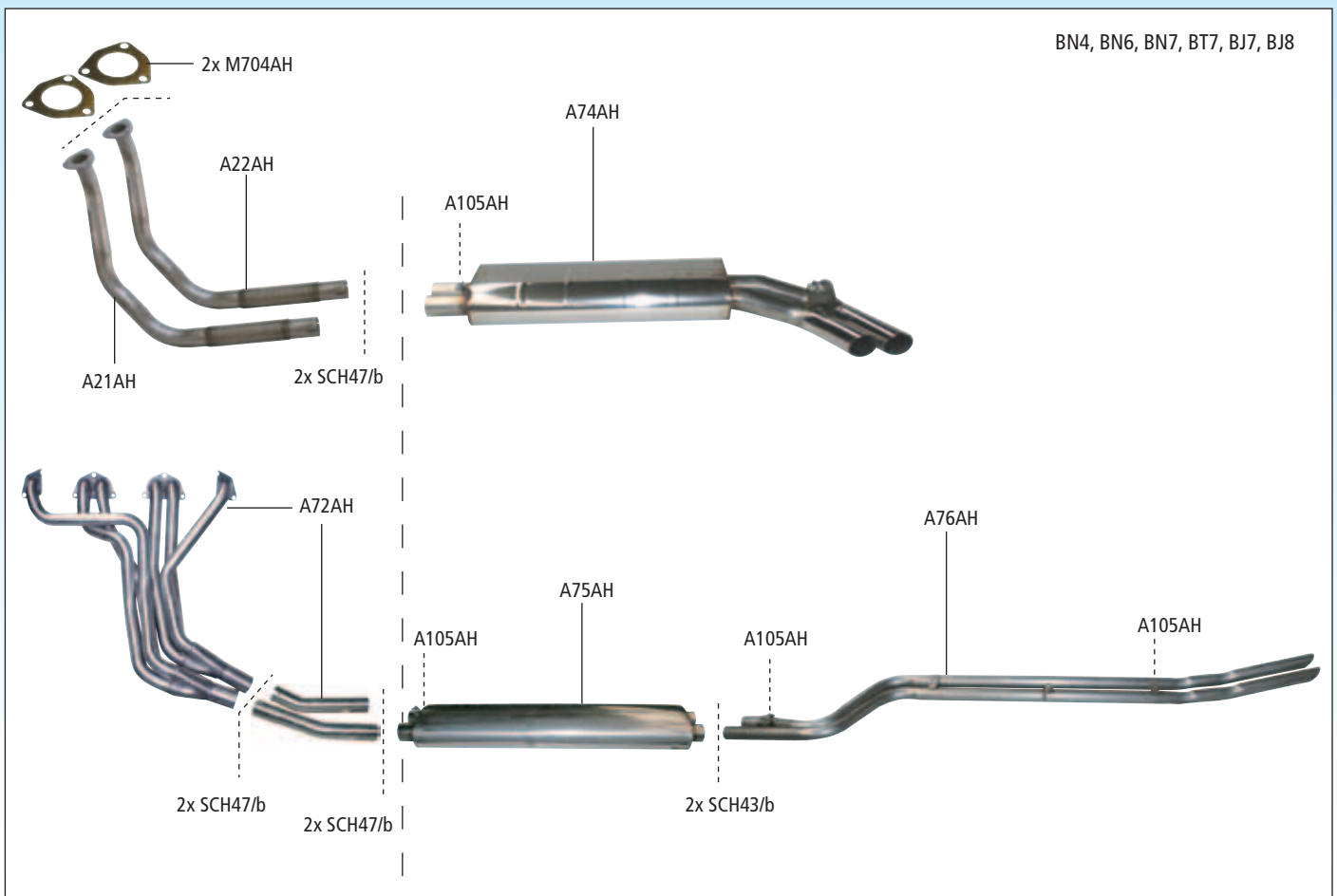
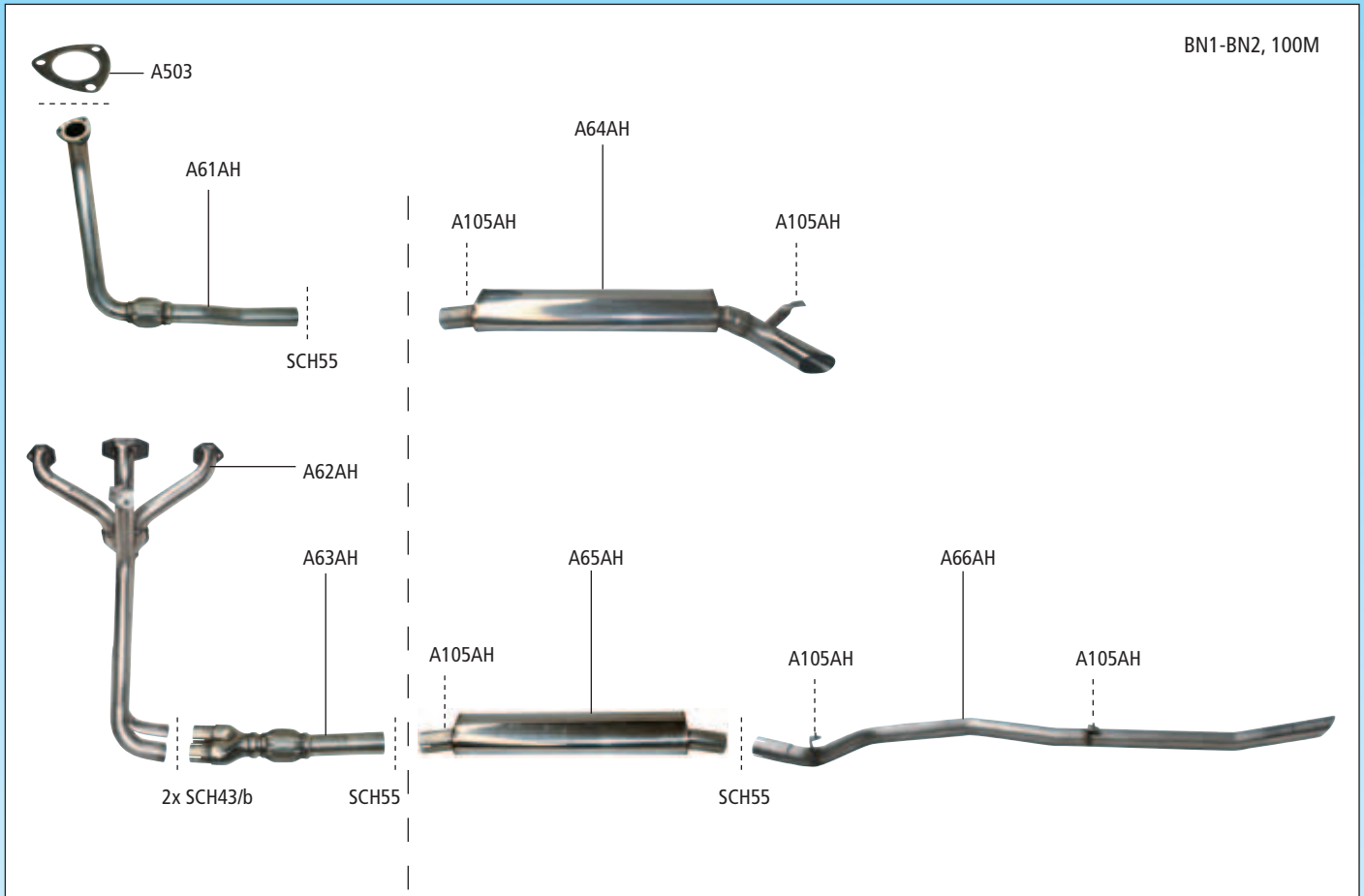

Sportauspuffanlage / Sport Exhaust (Big Bore) 2 1/2" (54 mm) BN1, BN2, 100M

No.	Bezeichnung	Description	Type	Anzahl/Qty.
A61AH	Hosenrohr mit Schlauchgelenk	front pipe with flexible pipe	BN1,BN2,100M	1
A62AH	Fächerkrümmer	sport manifold	BN1,BN2,100M	1
A63AH	Y-Stück mit Schlauchgelenk für Fächerkrümmer	Y-adaptor with flexible pipes for sport manifold	BN1,BN2,100M	1
A64AH	Schalldämpfer mit Endrohr seitlich „Big Bore“	rear silencer with tailpipes on the side „Big Bore“	BN1,BN2,100M	1
A65AH	Schalldämpfer „Big Bore“	rear silencer „Big Bore“	BN1,BN2,100M	1
A66AH	Endrohr „Big Bore“	rear exhaust pipe „Big Bore“	BN1,BN2,100M	1
SCH43/b	Edelstahl Bandschelle 43-47 mm	stainless steel clamp 43-47 mm	BN1,BN2,100M	2
SCH55	Edelstahl Schelle 55-59 mm	stainless steel clamp 55-59 mm	BN1,BN2,100M	1(2)
A105AH	Aufhängegummi	rubber hanger	BN1,BN2,100M	2(3)
A503	Hosenrohrdichtung	manifold gasket	BN1,BN2,100M	1

Sportauspuffanlage / Sport Exhaust (Big Bore) 47,4 mm BN4, BN6, BN7, BT7, BJ7, BJ8

No.	Bezeichnung	Description	Type	Anzahl/Qty.
A21AH	Vorderes Auspuffrohr links	front exhaust pipe left	BN4, BN6, BN7, BT7, BJ7	1
A22AH	Vorderes Auspuffrohr rechts	front exhaust pipe right	BN4, BN6, BN7, BT7, BJ7	1
A72AH	Fächerkrümmer incl. Verbindungsrohre	sport manifold	BN4, BN6, BN7, BT7, BJ7, BJ8	1
A74AH	Schalldämpfer mit Endrohr seitlich „Big Bore“	rear silencer with tailpipes on the side „Big Bore“	BN4, BN6, BN7, BT7, BJ7, BJ8	1
A75AH	Schalldämpfer „Big Bore“	rear silencer „Big Bore“	BN4, BN6, BN7, BT7, BJ7, BJ8	1
A76AH	Endrohrsatz „Big Bore“	rear exhaust pipe „Big Bore“	BN4, BN6, BN7, BT7, BJ7, BJ8	1
SCH43/b	Edelstahl Bandschelle 43-47mm	stainless steel clamp 43-47mm	BN4, BN6, BN7, BT7, BJ7, BJ8	2
SCH47/b	Edelstahl Bandschelle 47-51mm	stainless steel clamp 47-51mm	BN4, BN6, BN7, BT7, BJ7, BJ8	2(4)
A105AH	Aufhängegummi	rubber hanger	BN4, BN6, BN7, BT7, BJ7, BJ8	3
M704AH	Auspuffrohr-Dichtung	gasket	BN4, BN6, BN7, BT7, BJ7, BJ8	2

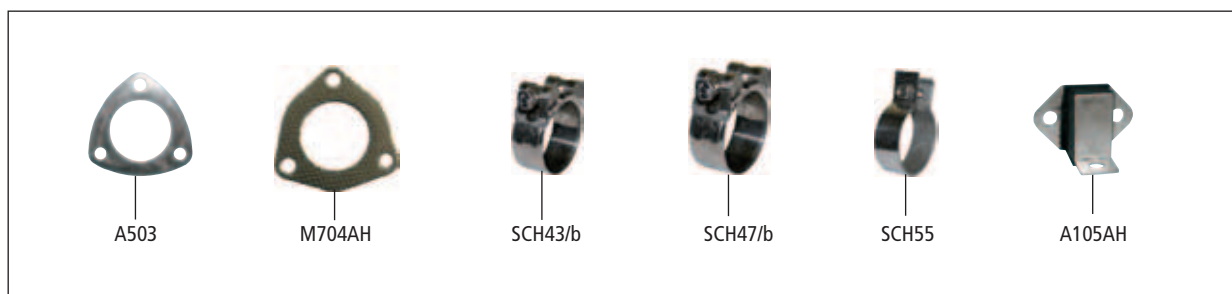

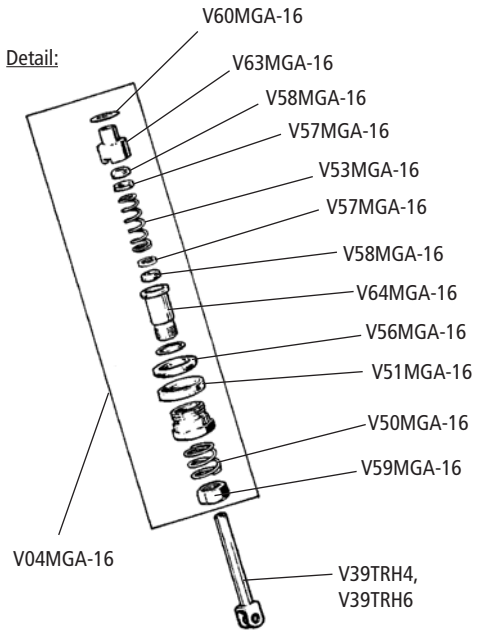
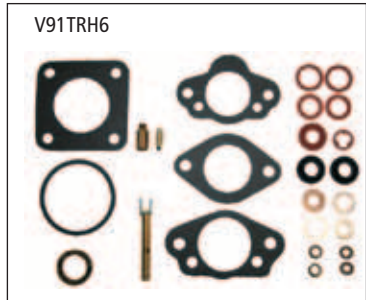
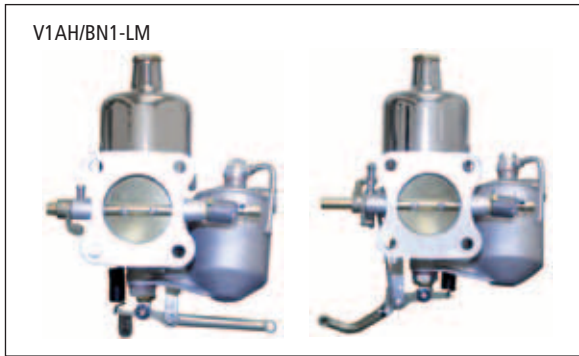
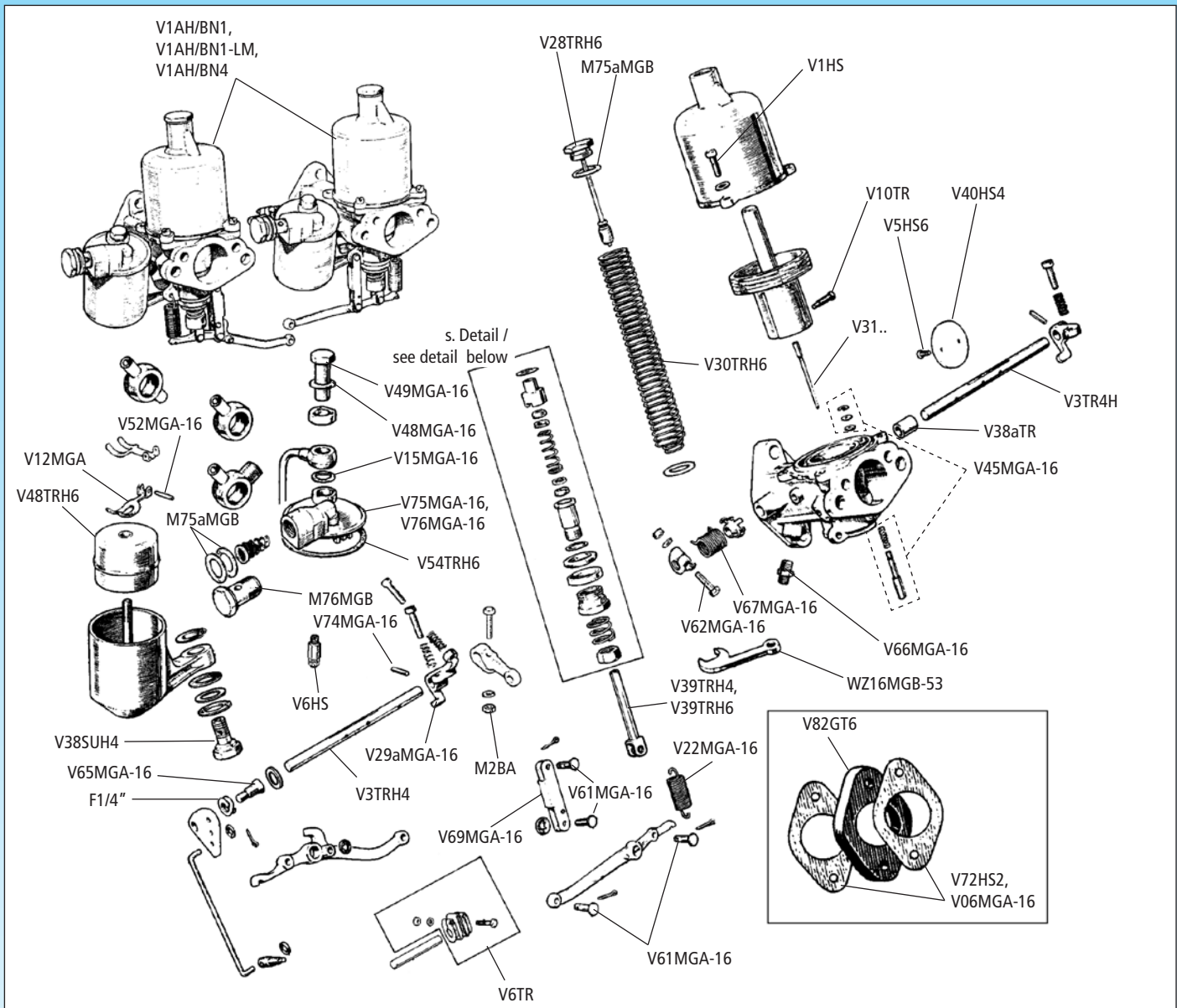

No.	Bezeichnung	Description	Type	Anzahl/Qty.
V1AH/BN1	AT-Vergaser-Paar H4	carburettor set H4, exchange	BN1, BN2	1
V1AH/BN1-LM	AT-Vergaser-Paar H6 „Le-Mans“	carburettor set H6 „Le Mans“, exchange	100M	1
V1AH/BN4	AT-Vergaser-Paar H4	carburettor set H4, exchange	BN4	1
V1HS	Schraube Schwimmerkammerdeckel	screw, chamber to body	BN1, BN2, BN4, 100M	6
M2BA	Mutter 2BA	nut	BN1, BN2, BN4, 100M	1
V3TRH4	Drosselklappenwelle	shaft, throttle	BN1, BN2, BN4	2
V04MGA-16	Lager-Satz Düsenstock	jet bearing kit	BN1, BN2, BN4, 100M	2
V5HS6	Schraube Drosselklappenwelle	screw	BN1, BN2, BN4, 100M	4
V06MGA-16	Dichtung Einlaßkrümmer/Vergaser	gasket, manifold to carburettor	BN4	2
V6TR	Doppelfeder Verbindung Gasgestänge	coupling assembly	BN1, BN2, BN4, 100M	2
V6HS	Schwimmernadelventil	needle and seat assembly	BN1, BN2, BN4, 100M	2
V10TR	Madenschraube Düsennadel	screw, needle locking	BN1, BN2, BN4, 100M	2
V12MGA	Vergaser-Schwimmer-Hebel	lever, hinged	BN1, BN2, BN4, 100M	2
V15MGA-16	Dichtscheibe Schwimmerdeckel/- lauffeitung	washer, fiber	100M	4
WZ16MGA-53	Einstellschlüssel Vergaser-Gemisch	wrench, jet adjusting	BN1, BN2, BN4, 100M	1
V22MGA-16	Rückholfeder Chokeybetätigungshebel	spring, jet lever return	BN1, BN2, BN4, 100M	2
V28TRH6	Dämpfer (Messing)	cap and damper assembly, brass	BN1, BN2, BN4, 100M	2
V29aMGA-16	Vergaserhebel	lever, throttle stop	BN1, BN2, BN4, 100M	1
V30HD6/BN4	Feder SU-Vergaser gelb	spring, piston return, yellow	BN1, BN2	2
V30TRH6	Feder SU-Vergaser rot	spring, piston return, red	100M, BN4	2
V31H4QA	Düsennadel QA, fett H4 Vergaser	needle, jet, rich QA (H4 carb.)	BN1, BN2	2
V31H4QW	Düsennadel QW, standard H4 Vergaser	needle, jet, std. QW (H4 carb.)	BN1, BN2	2
V31H4AT	Düsennadel AT, mager H4 Vergaser	needle, jet, lean AT (H4 carb.)	BN1, BN2	2
V31H6OA6	Düsennadel OA6, fett H6 Vergaser	needle, jet, rich OA6 (H6 carb.)	100M	2
V31H6OA7	Düsennadel OA7, standard H6 Vergaser	needle, jet, std. OA7 (H6 carb.)	100M	2
V31H6OA8	Düsennadel OA8, mager H6 Vergaser	needle, jet, lean OA8 (H6 carb.)	100M	2
V70MGA-16	Düsennadel 4, fett H4 Vergaser	needle, jet, rich 4 (H4 carb.)	BN4	2
V31H4/AJ	Düsennadel AJ, standard H4 Vergaser	needle, jet, std. AJ (H4 carb.)	BN4	2
V31H4/M1	Düsennadel M1, mager H4 Vergaser	needle, jet, lean M1 (H4 carb.)	BN4	2
V38SUH4	Hohlschraube Schwimmerkammer für Vergaser mit Fieberdichtung	bolt, chamber to body	BN1, BN2, BN4, 100M	2
V38aTR	Büchse Drosselklappenwelle 5/16"	bush, throttle shaft	BN1, BN2, BN4, 100M	4
V39TRH4	Düsenstock	jet	BN1, BN2, BN4	2
V39TRH6	Düsenstock	jet	100M	2
V40HS4	Drosselklappe	disc, throttle	BN1, BN2, BN4	2
V45MGA-16	Hebestiftsatz Kolben	pin and spring assembly	BN1, BN2, BN4, 100M	2
V48TRH6	Schwimmer (Messing)	float, brass	BN1, BN2, BN4, 100M	2
V48MGA-16	Scheibe Aluminium	washer aluminum	BN1, BN2, BN4, 100M	2
V49MGA-16	Halteschraube Deckel Schimmerkammer	cap nut	100M	2
V50MGA-16	Feder für Einstellmutter	spring, adjusting nut	BN1, BN2, BN4, 100M	2
V51MGA-16	Dichtscheibe Aluminium	ring, sealing (aluminum)	BN1, BN2, BN4, 100M	2
V52MGA-16	Lagerstift Schwimmer	pin	BN1, BN2, BN4, 100M	2
V53MGA-16	Feder für Düsendichtringe	spring, gland	BN1, BN2, BN4, 100M	2
V54TRH6	Schwimmerkammerdeckeldichtung	gasket, float chamber lid	BN1, BN2, BN4, 100M	2
V56MGA-16	Korkscheibe	ring, sealing (cork)	BN1, BN2, BN4, 100M	2
V57MGA-16	Messingring für Düsendichtring	washer, gland (brass)	BN1, BN2, BN4, 100M	4
V58MGA-16	Korkdichtring für Düse	washer, gland (cork)	BN1, BN2, BN4, 100M	4
V59MGA-16	Düseneinstellmutter	nut, adjusting	BN1, BN2, BN4, 100M	2
V60MGA-16	Kupferscheibe Düsenstock oben	washer, top bearing (copper)	BN1, BN2, BN4, 100M	2
V63MGA-16	Obere Düsenführung	bearing, top	BN1, BN2, BN4, 100M	2
V64MGA-16	Lager Düsenstock unten	bearing, buttom	BN1, BN2, BN4, 100M	2
V61MGA-16	Lagerstift	pin	BN1, BN2, BN4, 100M	2
V62MGA-16	Schraube	bolt	BN1, BN2, BN4, 100M	6
V65MGA-16	Bolzen	bolt, pivot	BN1, BN2, BN4, 100M	1
V66MGA-16	Anschluß Unterdruckleitung	union, vacuum advance, rear carb.	BN1, BN2, BN4, 100M	1
V69MGA-16	Verbindungsbügel	link, jet lever	BN1, BN2, BN4, 100M	1/2
V72HS2	Ansaugstutzendichtung	gasket, manifold to carb.	BN1, BN2	2/4
V74MGA-16	Stift	pin, tapered	BN1, BN2, BN4, 100M	1/2

- Fortsetzung nächste Seite

- to be continued next page

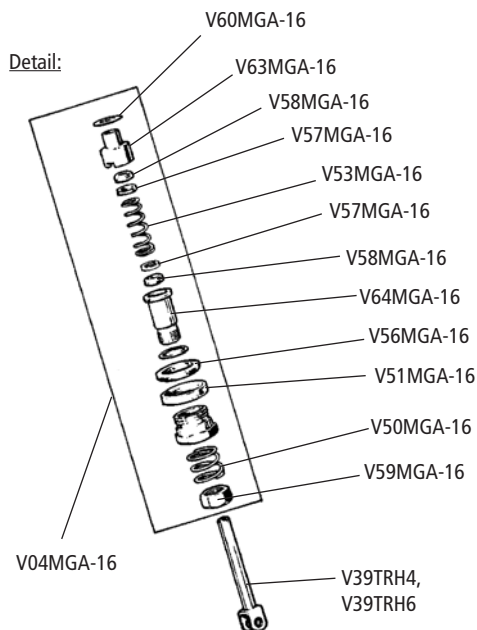
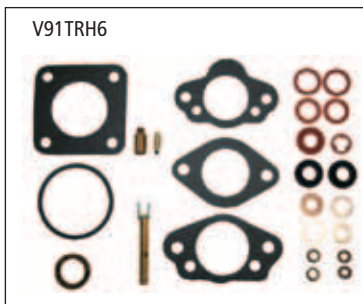
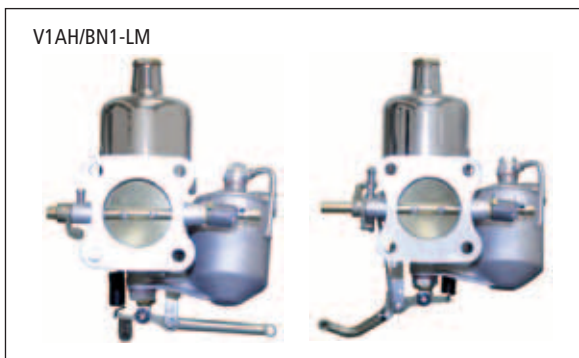
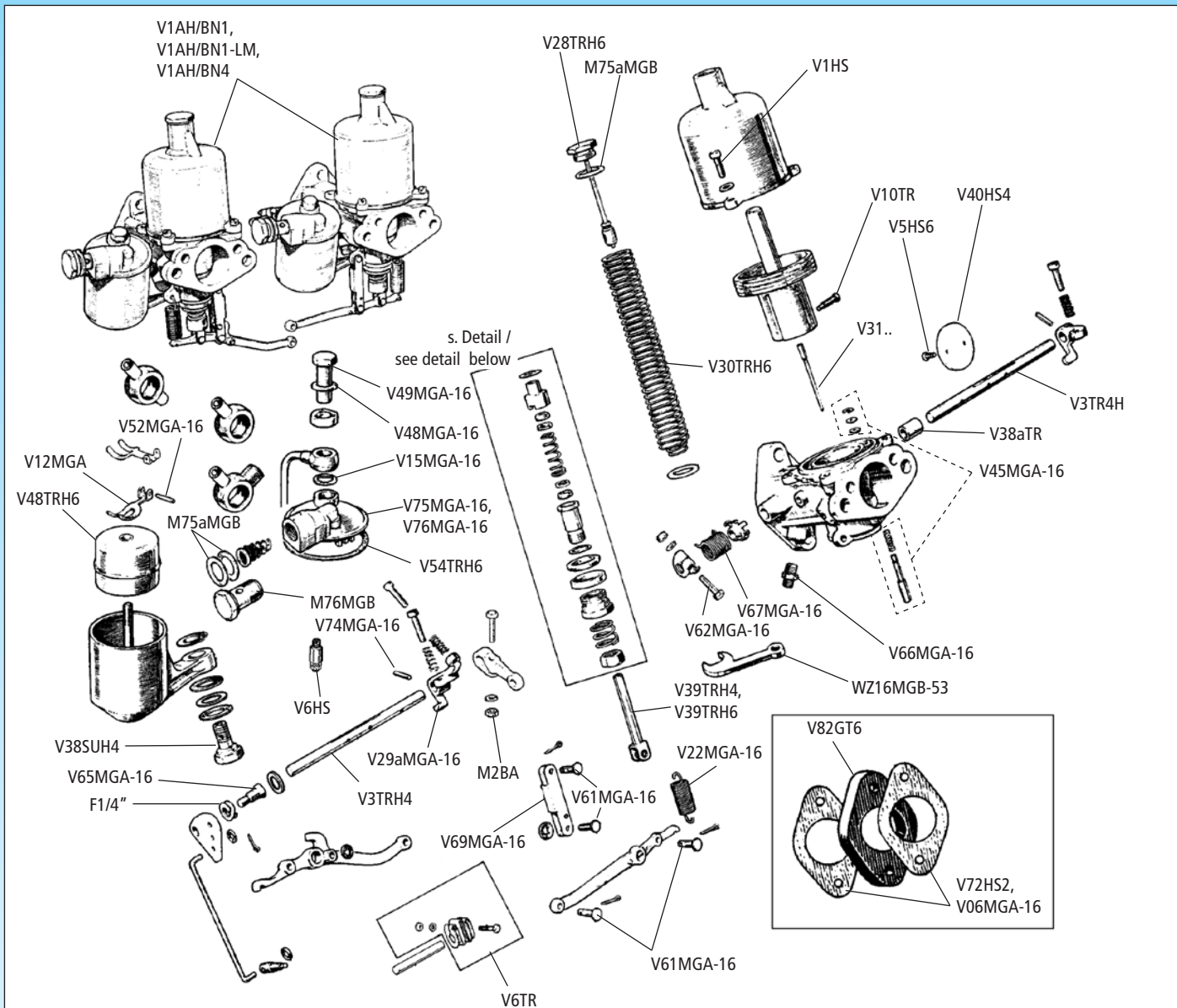

No.	Bezeichnung	Description	Type	Anzahl/Qty.
M75aMGB	Dichtung	washer, fiber	BN1, BN2, BN4, 100M	A/R
V67MGA-16	Rückholfeder Gasgestänge vorne	spring, return	BN1, BN2, BN4, 100M	2
V75MGA-16	Deckel Schwimmerkammer mit Hebel vo. + hi.	lid, float chamber, front + rear	BN1, BN2, 100M	2
V75MGA-16	Deckel Schwimmerkammer mit Hebel hinten	lid, float chamber, rear	BN4	1
V76MGA-16	Deckel Schwimmerkammer mit Hebel vorne	lid, float chamber, front	BN4	1
M76MGB	Schraube Banjo Anschluß	bolt, banjo	BN1, BN2, BN4, 100M	2
V82GT6	Isolierflansch	distance piece	BN1, BN2	2
V90TRH6	Vergaserdichtsatz für 1 Vergaser H4/H6	gasket kit for 1 carb. H4/H6	BN1, BN2, BN4, 100M	2
V91TRH4	Vergaserreparatursatz für 1 Vergaser H4	rebuild kit for 1 carb. H4	BN1, BN2, BN4	2
V91TRH6	Vergaserreparatursatz für 1 Vergaser H6	rebuild kit for 1 carb. H6	100M	2
SU-VÖ	SU Vergaseröl 150 ml	oil, SU carb. 150 ml	BN1, BN2, BN4, 100M	A/R

Luftfilter / Air cleaner

V73HS4	Luftfilterdichtung HS4-Vergaser	gasket, air cleaner to carb.	BN1, BN2, BN4	2
V75AH-v/BN1	Luftfilter vorne (ohne Filterelement)	air cleaner, front (filter element not included)	BN1, BN2, BN4	1
V75AH-h/BN1	Luftfilter hinten (ohne Filterelement)	air cleaner, rear (filter element not included)	BN1, BN2, BN4	1
V75AHS4	Chromluftfilter HS4	air cleaner, chrome, HS4 carbs.	BN1, BN2, BN4	2
V75KNHS4	K+N Luftfilter HS4-Vergaser, Bauhöhe 45 mm	air cleaner, K&N type, HS4 carbs., 45 mm high	BN1, BN2, BN4	2
V75KNHS6	K+N Luftfilter HS6/H6/HD6, 175CD Vergaser 45 mm	air cleaner K&N type, HS6/H6,HD6, 175CD carbs. 45 mm high	100M	2
V76AH	Filterelement (Ersatz für orig. Filterelement)	filter element (replaces orig. part)	BN1, BN2, BN4	2
V84aTRH6	Chromluftfilter für H6 u.HS6 Vergaser	air cleaner, chrome, H6 and HS6 carbs.	100M	2
V92TRH6	Luftfilterdichtung H6/HS6 175CD	gasket, air cleaner to carb.	100M	2
EM122AH	Aufkleber Luftfilter Burgess	I.D. plate, Burgess, air cleaners	BN1, BN2, BN4	2

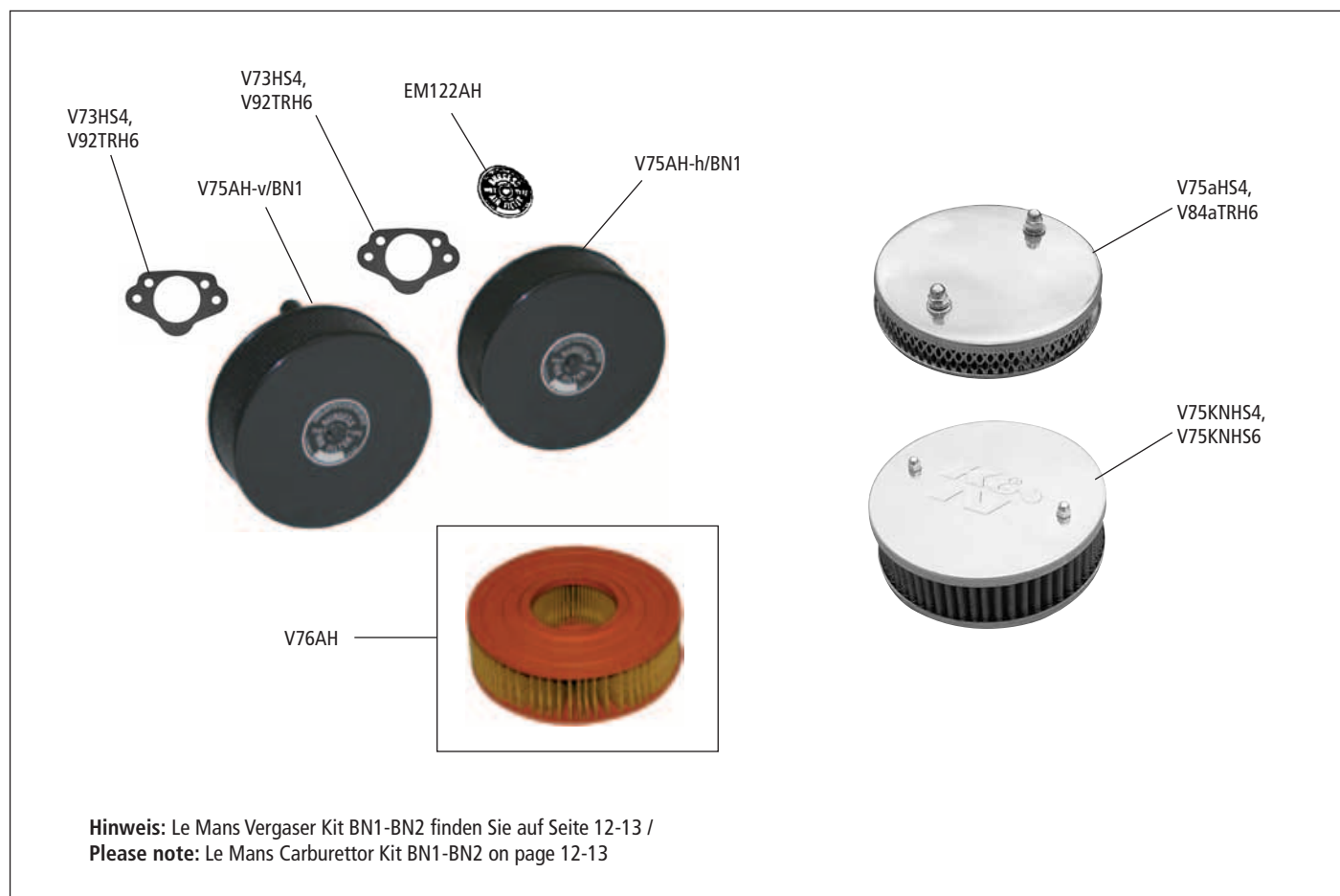

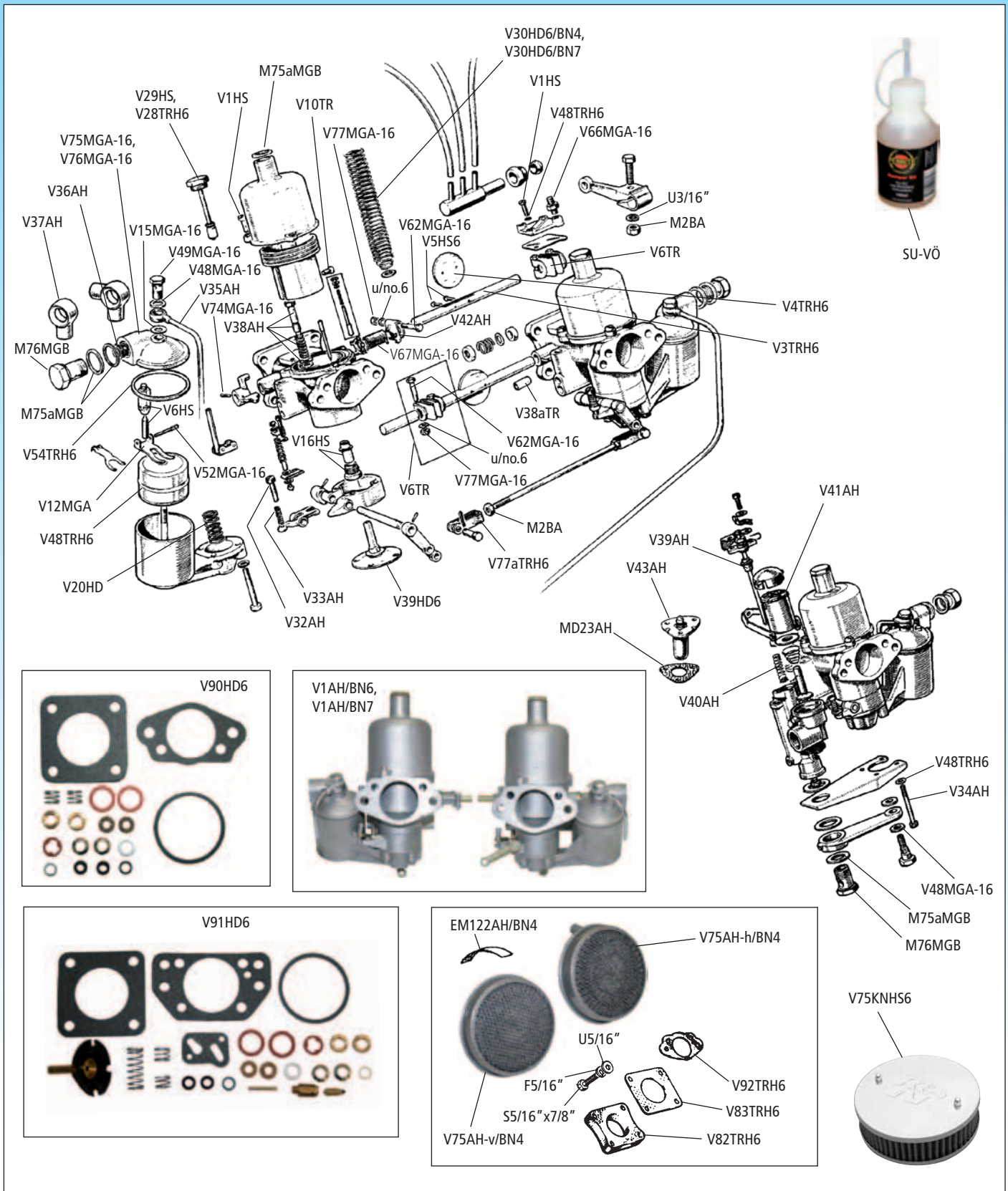

No.	Bezeichnung	Description	Type	Anzahl/Qty.
V1AH/BN7	AT-Vergaser-Paar	carburettor set, exchange	BN7, BT7	1
V1AH/BN6	AT-Vergaser-Paar	carburettor set, exchange	BN4, BN6	1
V1HS	Schraube	screw	BN4, BN6, BN7, BT7	A/R
M2BA	Mutter 2BA	nut 2BA	BN4, BN6, BN7, BT7	1/2
V3TRH6	Drosselklappenwelle	shaft, throttle	BN4, BN6, BN7, BT7	2
V4TRH6	Drosselklappe	disc, throttle	BN4, BN6, BN7, BT7	2

No.	Bezeichnung	Description	Type	Anzahl/Qty.
V5HS6	Schraube Drosselklappenwelle	screw	BN4, BN6, BN7, BT7	4
V6TR	Doppelfeder Verbindung Gasgestänge	coupling assembly	BN4, BN6, BN7, BT7	2
V6HS	Schwimmernadelventil	needle and seat assembly	BN4, BN6, BN7, BT7	2
V10TR	Madenschraube Düsennadel	screw, needle locking	BN4, BN6, BN7, BT7	2
V12MGA	Vergaser-Schwimmer-Hebel (für orig. Deckel)	lever, hinged	BN4, BN6, BN7, BT7	2
V15MGA-16	Dichtscheibe Schwimmerdeckel/-laufleitung	washer, fiber	BN4, BN6, BN7, BT7	1/2
V16HS	Einstellteil Düsenstock	jet bearing kit	BN4, BN6, BN7, BT7	2
V20HD	Feder Düsenstock	spring, jet return	BN4, BN6, BN7, BT7	2
MD23AH	Dichtung Deckel Zylinderkopf	gasket	BN7 & BT7 (AUC935)	1
V28TRH6	Vergaserdämpfer (Messing)	cap and damper assembly, brass	BN4, BN6, BN7, BT7 bis 29D-H2863	2
V29HS	Vergaserdämpfer	cap and damper assembly, brass	BN7, BT7 ab 29D-H2864	2
V30HD6/BN4	Feder SU-Vergaser gelb	spring, piston return, yellow	BN4, BN6	2
V30HD6/BN7	Feder SU-Vergaser grün	spring, piston return, green	BN7, BT7	2
V31HD6RD	Düsennadel RD, fett	needle, jet, rich RD	BN4, BN6, BN7, BT7	2
V31HD6CV	Düsennadel CV, standard	needle, jet, rich std. CV	BN4, BN6, BN7, BT7	2
V31HD6SQ	Düsennadel SQ, mager	needle, jet, lean SQ	BN4, BN6, BN7, BT7	2
V32AH	Leerlauf-Anschlagschraube	screw, jet adjusting	BN4, BN6, BN7, BT7	2
V33AH	Feder Einsteller	spring	BN4, BN6, BN7, BT7	2
V34AH	Befestigungsschraube Gehäuse	bolt, chamber to body	BN4, BN6, BN7, BT7	8
V35AH	Überlaufrohr CTF	drain pipe	BN4, BN6, BN7, BT7	2
V36AH	Filter Schwimmerkammer	filter	BN4, BN6, BN7, BT7	2
V37AH	Banjo Anschluß	banjo, union	BN4, BN6, BN7, BT7	1
V38AH	Ablaufventil Kit	slow running valve kit	BN4, BN6, BN7, BT7	2
V38aTR	Büchse Drosselklappenwelle 5/16"	bush, throttle shaft	BN4, BN6, BN7, BT7	4
V39HD6	Düsenstock	jet assembly	BN4, BN6, BN7, BT7	2
V39AH	Düsennadel Einheit	needle, assembly	BN7, BT7 29D-H2864 bis 29D-H6394	1
V40AH	Feder für Düsennadel blau	spring, blue, for needle	BN7, BT7 29D-H2864 bis 29D-H6394	1
V41AH	Magnetventil Automatik-Choke	solenoid assembly	BN7, BT7 29D-H2864 bis 29D-H6394	1
V42AH	Clip Drosselklappenwelle	clip	BN4, BN6, BN7, BT7	2
V43AH	Thermoschalter	switch, thermal	BN7 & BT7 (AUC935)	1
V48TRH6	Schwimmer (Messing)	float	BN4, BN6, BN7, BT7	2
V48MGA-16	Scheibe Aluminium	washer, aluminum	BN4, BN6, BN7, BT7	1/2
V49MGA-16	Halteschraube für Schwimmerkammerdeckel	cap nut	BN4, BN6, BN7, BT7	2
V52MGA-16	Lagerstift Schwimmer	pin	BN4, BN6, BN7, BT7	2
V54TRH6	Schwimmerkammerdeckeldichtung	gasket, float chamber lid	BN4, BN6, BN7, BT7	2
V62MGA-16	Schraube	bolt	BN4, BN6, BN7, BT7	A/R
V66MGA-16	Anschluß Unterdruckleitung	union, vacuum advance	BN4, BN6, BN7, BT7	1
V67MGA-16	Rückholfeder Gasgestänge vorne	spring, return	BN4, BN6, BN7, BT7	2
V74MGA-16	Stift	pin, tapered	BN4, BN6, BN7, BT7	A/R
V75MGA-16	Deckel Schwimmerkammer mit Hebel hinten	lid, float chamber, rear	BN4, BN6, BN7, BT7	A/R
M75aMGB	Dichtung	washer, fiber	BN4, BN6, BN7, BT7	1/4
M76MGB	Schraube Banjo Anschluß	bolt banjo	BN4, BN6, BN7, BT7	1/2
V76MGA-16	Deckel Schwimmerkammer mit Hebel vorne	lid, float chamber, with lever, front	BN4, BN6, BN7, BT7	1
V77MGA-16	Feststellmutter Gasgestänge 4B A	nut	BN4, BN6, BN7, BT7	2/4
V77aTRH6	Gabel	fork	BN4, BN6, BN7, BT7 AUC914 & AUC963	2
V90HD6	Vergaserdichtsatz	gasket kit	BN4, BN6, BN7, BT7	2
V91HD6	Vergaserreparatursatz 1 Vergaser	rebuild kit for 1 carb.	BN4, BN6, BN7, BT7	2
u/no.6	Unterlegscheibe No.6, 1/8"	washer, plain	BN4, BN6, BN7, BT7	2/4
SU-VÖ	SU Vergaseröl 150 ml	oil, SU carb. 150 ml	BN4, BN6, BN7, BT7	A/R

Luftfilter / Air cleaner

V75AH-V/BN4	Luftfilter vorne (ohne Stutzen)	air cleaner, front (with connection)	BN4, BN6, BN7, BT7	1
V75AH-H/BN4	Luftfilter hinten (mit Stutzen)	air cleaner, rear (w/o connection)	BN4, BN6, BN7, BT7	1
V75KNHS6	K&N Luftfilter 63 mm	air cleaner, K&N type, 63 mm	BN4, BN6, BN7, BT7	2
V82TRH6	Isolierflansch	insulating block	BN4, BN6, BN7, BT7	2
V83TRH6	Dichtung	gasket	BN4, BN6, BN7, BT7	2
V92TRH6	Luftfilterdichtung	gasket, air cleaner to carb.	BN4, BN6, BN7, BT7	2
EM122AH/BN4	Aufkleber Luftfilter Cooper	decals, air cleaners	BN4, BN6, BN7, BT7	2

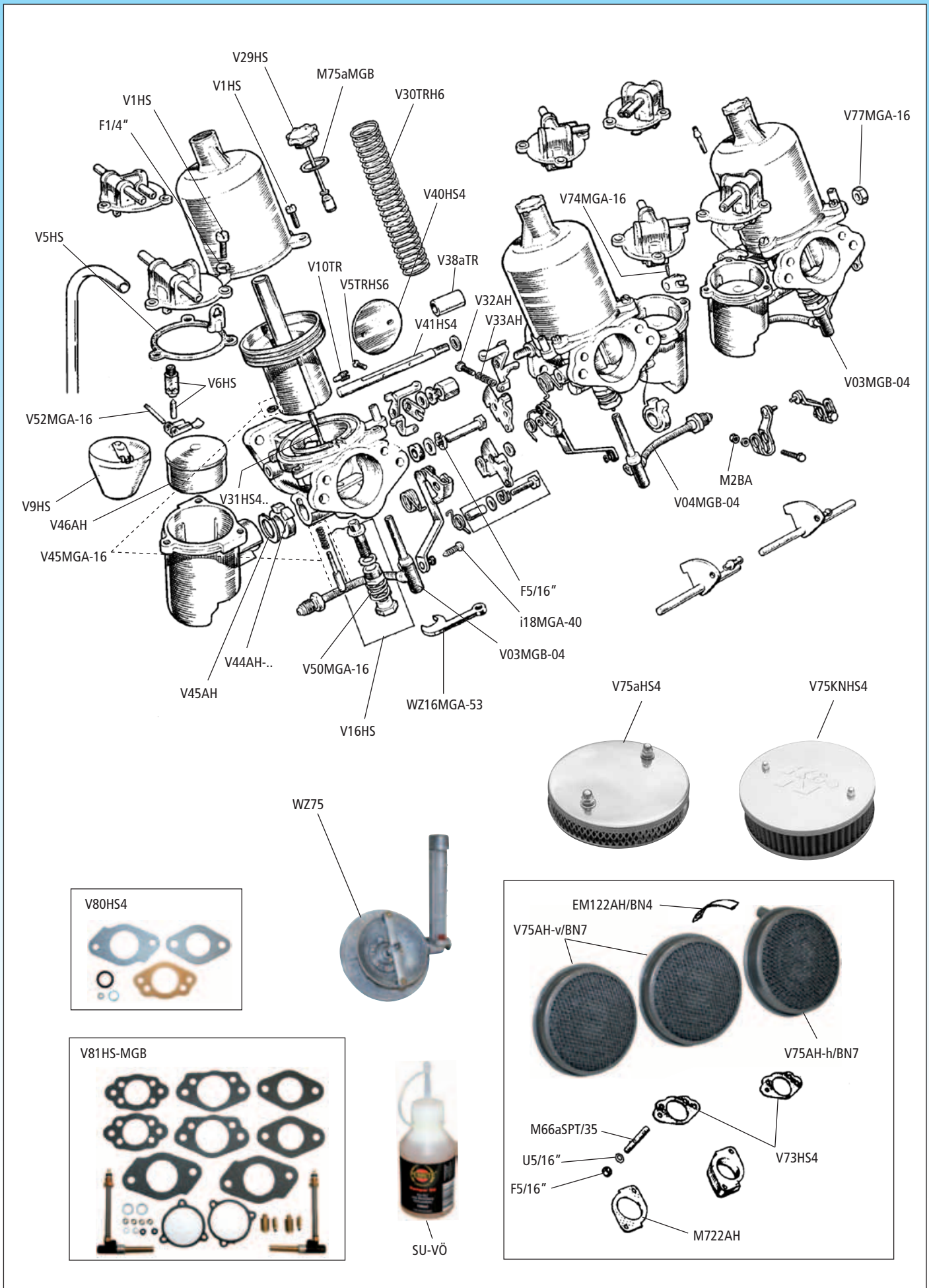

No.	Bezeichnung	Description	Type	Anzahl/Qty.
V1AH/BT7	AT-Vergaser-Satz (3-Vergaser)	carburettor set (3 carbs.), exchange	BN7, BT7	1
V1HS	Schraube Schwimmerkammerdeckel	screw, chamber to body	BN7, BT7	18
M2BA	Mutter 2BA	nut 2BA	BN7, BT7	3
V03MGB-04	Düsenstock vorderer + hinterer Vergaser	jet assembly, front & rear carbs.	BN7, BT7	2
V04MGB-04	Düsenstock mittlerer Vergaser	jet assembly, center carb.	BN7, BT7	1
V5HS6	Schraube Drosselklappenwelle	screw	BN7, BT7	6
V5HS	Schwimmerkammerdeckeldichtg	gasket, float chamber lid	BN7, BT7	3
V6HS	Schwimmernadelventil	needle & seat assembly	BN7, BT7	2/3
V9HS	Schwimmer	float	BN7, BT7	2
V10TR	Madenschraube Düsennadel	screw, needle locking	BN7, BT7	3
WZ16MGA-53	Einstellschlüssel Vergaser-Gemisch	wrench, jet adjusting	BN7, BT7	1
i18MGA-40	Befestigungsschraube No.6x5/8"	screw, self-tapping	BN7, BT7	3
V29HS	Vergaserdämpfer	cap and damper assembly	BN7, BT7	3
V30TRH6	Feder SU-Vergaser rot	spring, piston return, red	BN7, BT7	3
V31HS4DK	Düsennadel DK, fett	needle, jet, rich DK	BN7, BT7	3
V31HS4DJ	Düsennadel DJ standard	needle, jet, std. DJ	BN7, BT7	3
V31HS4DH	Düsennadel DH, mager	needle, jet, lean DH	BN7, BT7	3
V32AH	Leerlauf-Anschlagschraube	screw, throttle stop	BN7, BT7	6
V33AH	Feder Einsteller	spring	BN7, BT7	6
V38aTR	Büchse Drosselklappenwelle 5/16"	bush, throttle shaft	BN7, BT7	6
V41HS4	Drosselklappenwelle	shaft, throttle standard	BN7, BT7	3
V40HS4	Drosselklappe	disc, throttle	BN7, BT7	3
V44AH-V+H/F	Adapter Schwimmerkammer vorne/ hinten	adaptor, front & rear carbs.	BN7, BT7 < 29E-H928	2
V44AH-V+H/S	Adapter Schwimmerkammer vorne/ hinten	adaptor, front & rear carbs.	BN7, BT7 > 29E-H929	2
V44AH-M/F	Adapter-Schwimmerkammer mitte	adaptor, center carb.	BN7, BT7 < 29E-H928	1
V44AH-M/S	Adapter Schwimmerkammer mitte	adaptor, center carb.	BN7, BT7 > 29E-H929	1
V45AH	Vergaser-Scheibe Schwimmer	washer, adaptor	BN7, BT7 > 29E-H929	3
V45MGA-16	Hebestiftsatz Kolben	pin & spring assembly	BN7, BT7	3
V46AH	Vergaser-Schwimmer Messing	float, brass	BN7, BT7 < 29E-H2994	3
V50MGA-16	Feder für Einstellmutter	spring, jet return	BN7, BT7	3
V52MGA-16	Lagerstift Schwimmer	pin	BN7, BT7	3
V74MGA-16	Stift	pin, tapered	BN7, BT7	2
M75aMGB	Dichtung	washer, fiber	BN7, BT7	3
V77MGA-16	Feststellmutter Gasgestänge 4BA	nut, for lever, rear carb.	BN7, BT7	1
V80HS4	Vergaserdichtsatz 1 Vergaser	gasket kit, for 1 carb.	BN7, BT7	3
V81HS-MGB	Rep.-Satz Vergaser für vorderen + mittleren Vergaser	rebuild kit, for front + center carbs.	BN7, BT7	1
V81HS-BN7	Rep.-Satz Vergaser für hinteren Vergaser	rebuild kit, for rear carb.	BN7, BT7	1
SU-VÖ	SU Vergaseröl 150 ml	oil, SU carb. 150 ml	BN7, BT7	A/R

Luftfilter / Air cleaner

M66aSPT/35	Stehbolzen UNF 5/16"	stud, air cleaner to carb.	BN7, BT7	6
V73HS4	Luftfilterdichtung	gasket, air cleaner to carb.	BN7, BT7	3
V75AH-V/BN7	Luftfilter vorne & mitte (ohne Stutzen)	air cleaner, front & center (with connection)	BN7, BT7	2
V75AH-H/BN7	Luftfilter hinten (mit Stutzen)	air cleaner, rear (w/o connection)	BN7, BT7	1
V75aHS4	Chromluftfilter	air cleaner, chrome	BN7, BT7	3
V75KNHS4	K+N Luftfilter	air cleaner, K&N type	BN7, BT7	3
EM122AH/BN4	Aufkleber Luftfilter	decal, air cleaners	BN7, BT7	3
M722AH	Vergaser-Dichtung 3-fach Vergaser	gasket carb. mounting	BN7, BT7	3/6
WZ75	Vergaser-Synchro-Tester	carburettor synchronizer	BN7, BT7	A/R

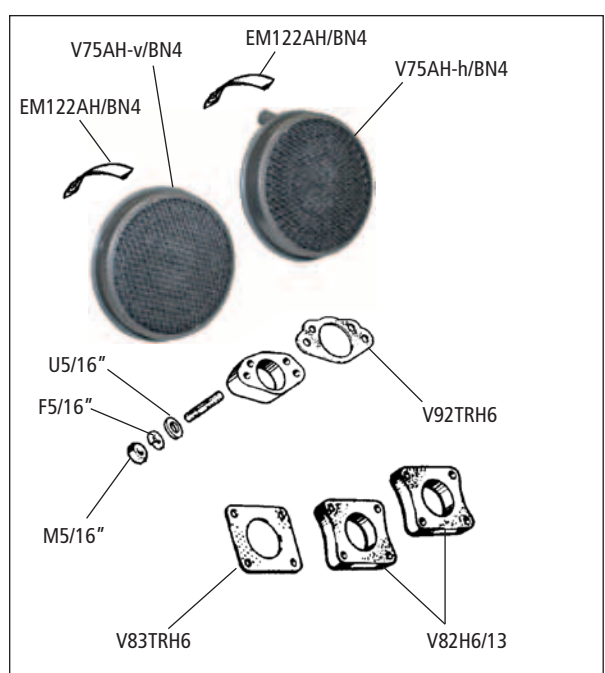
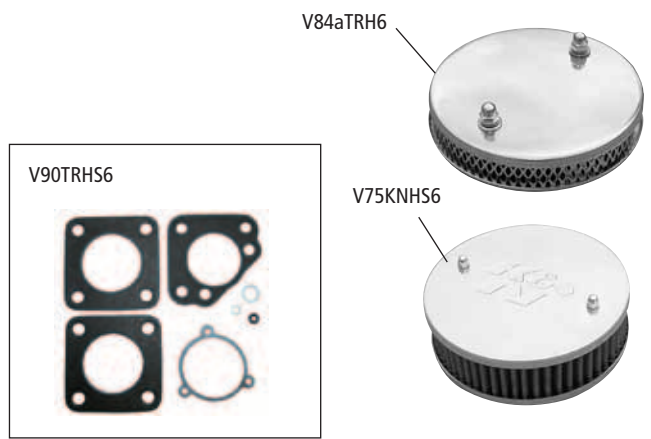
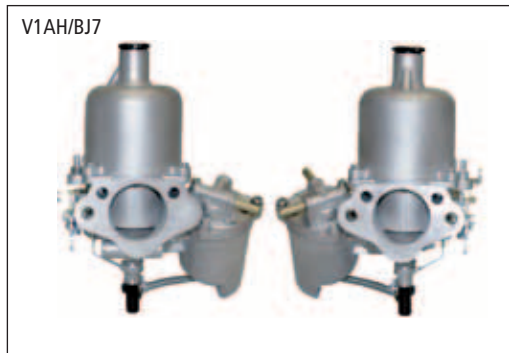
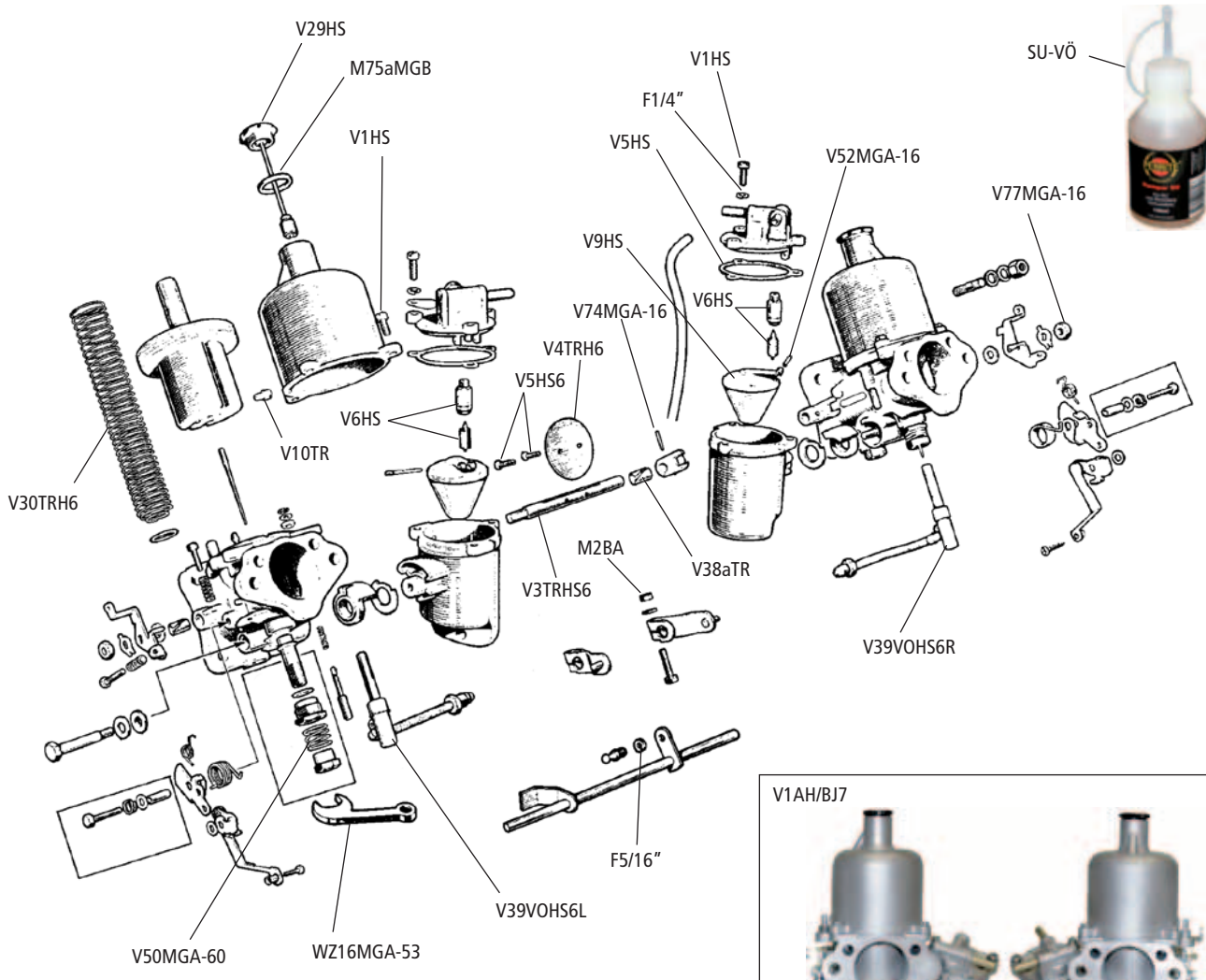

No.	Bezeichnung	Description	Type	Anzahl/Qty.
V1AH/BJ7	AT-Vergaser-Paar	carburettor set, exchange	BJ7	1
V1HS	Schraube Schwimmerkammerdeckel / Schraube Vergaserdeckel	screw, float chamber lid / screw chamber to body	BJ7 BJ7	6 6
M2BA	Mutter 2BA	nut	BJ7	2
V3TRHS6	Drosselklappenwelle	shaft, throttle	BJ7	2
V4TRH6	Drosselklappe	disc, throttle	BJ7	2
V5HS	Schwimmerkammerdeckeldichtung	gasket, float chamber lid	BJ7	2
V5HS6	Schraube Drosselklappenwelle	screw	BJ7	4
V6HS	Schwimmernadelventil	needle and seat	BJ7	2
V9HS	Schwimmer	float	BJ7	2
V10TR	Madenschraube Düsennadel	screw, needle locking	BJ7	2
WZ16MGA-53	Einstellschlüssel Vergasergemisch	wrench, jet adjusting	BJ7	1
V29HS	Vergaserdämpfer	cap and damper assembly	BJ7	2
V31HD6RD	Düsennadel RD, fett	needle, jet, rich RD	BJ7	2
V31HS6BC	Düsennadel BC, standard	needle, jet, std. BC	BJ7	2
V31HS6TZ	Düsennadel TZ, mager	needle, jet lean TZ	BJ7	2
V38aTR	Büchse Drosselklappenwelle 5/16"	bush, throttle shaft	BJ7	4
V39VOHS6L	Düsenstock vorne	jet assembly, front carb.	BJ7	1
V39VOHS6R	Düsenstock hinten	jet assembly, rear carb.	BJ7	1
V44AH-M/S	Adapter Schwimmerkammer vorne	adaptor, front carb.	BJ7	1
V44AH-V+H/S	Adapter Schwimmerkammer hinten	adaptor, rear carb.	BJ7	1
V50MGA-16	Feder für Einstellmutter	spring, jet adjuster	BJ7	2
V52MGA-16	Lagerstift Schwimmer	pin	BJ7	2
V74MGA-16	Stift	pin, tapered	BJ7	2
M75aMGB	Dichtung	washer, fiber	BJ7	2
V77MGA-16	Feststellmutter Gasgestänge 4BA	nut, for lever, front and rear carbs.	BJ7	2
V90TRHS6	Vergaserdichtsatz (1 Vergaser)	gasket kit for 1 carb.	BJ7	2
V91TRHS6L	Vergaserreparatursatz vorderer Vergaser	rebuild kit, front carb.	BJ7	1
V91TRHS6R	Vergaserreparatursatz hinterer Vergaser	rebuild kit, rear carb.	BJ7	1
SU-VÖ	SU Vergaseröl, 150 ml	oil, SU carb. 150 ml	BJ7	A/R

Luftfilter / Air cleaner

V75AH-V/BN4	Luftfilter vorne (ohne Stutzen)	air cleaner, front (with connection)	BJ7	1
V75AH-H/BN4	Luftfilter hinten (mit Stutzen)	air cleaner, rear (w/o connection)	BJ7	1
V75KNHS6	K+N Luftfilter	air cleaner K&N type	BJ7	2
V82H6/13	Isolierflansch 13mm dick	insulating block, 13 mm thick	BJ7	4
V83TRH6	Dichtung	gasket, carb. mounting	BJ7	2
V84aTRH6	Chromluftfilter	air cleaner, chrome	BJ7	2
V92TRH6	Luftfilterdichtung	gasket, air cleaner to carb.	BJ7	2
EM122AH/BN4	Aufkleber Luftfilter Cooper	decals, air cleaners Coopers	BJ7	A/R

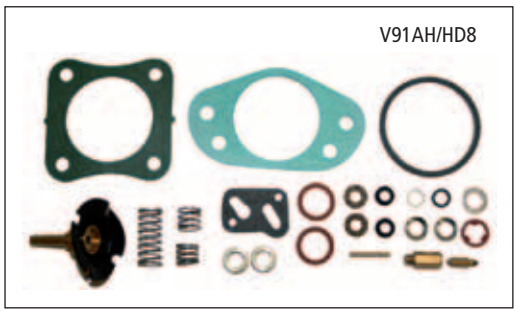
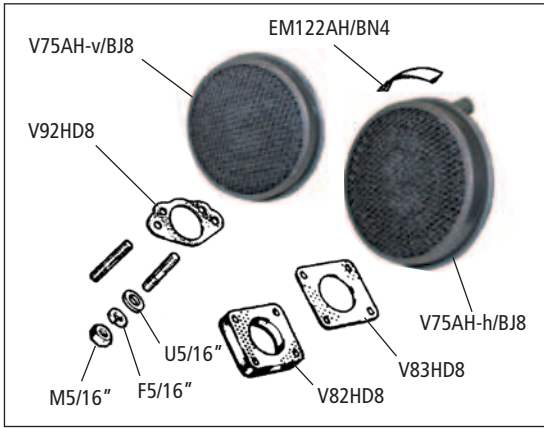
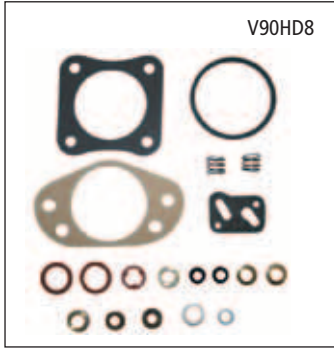
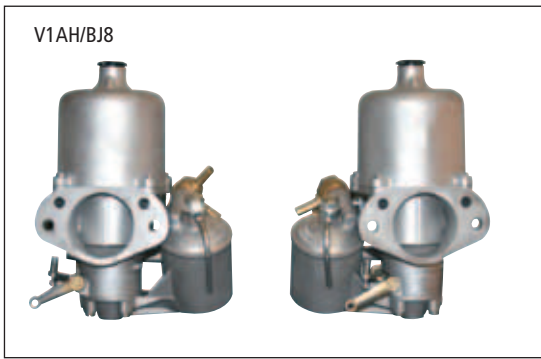
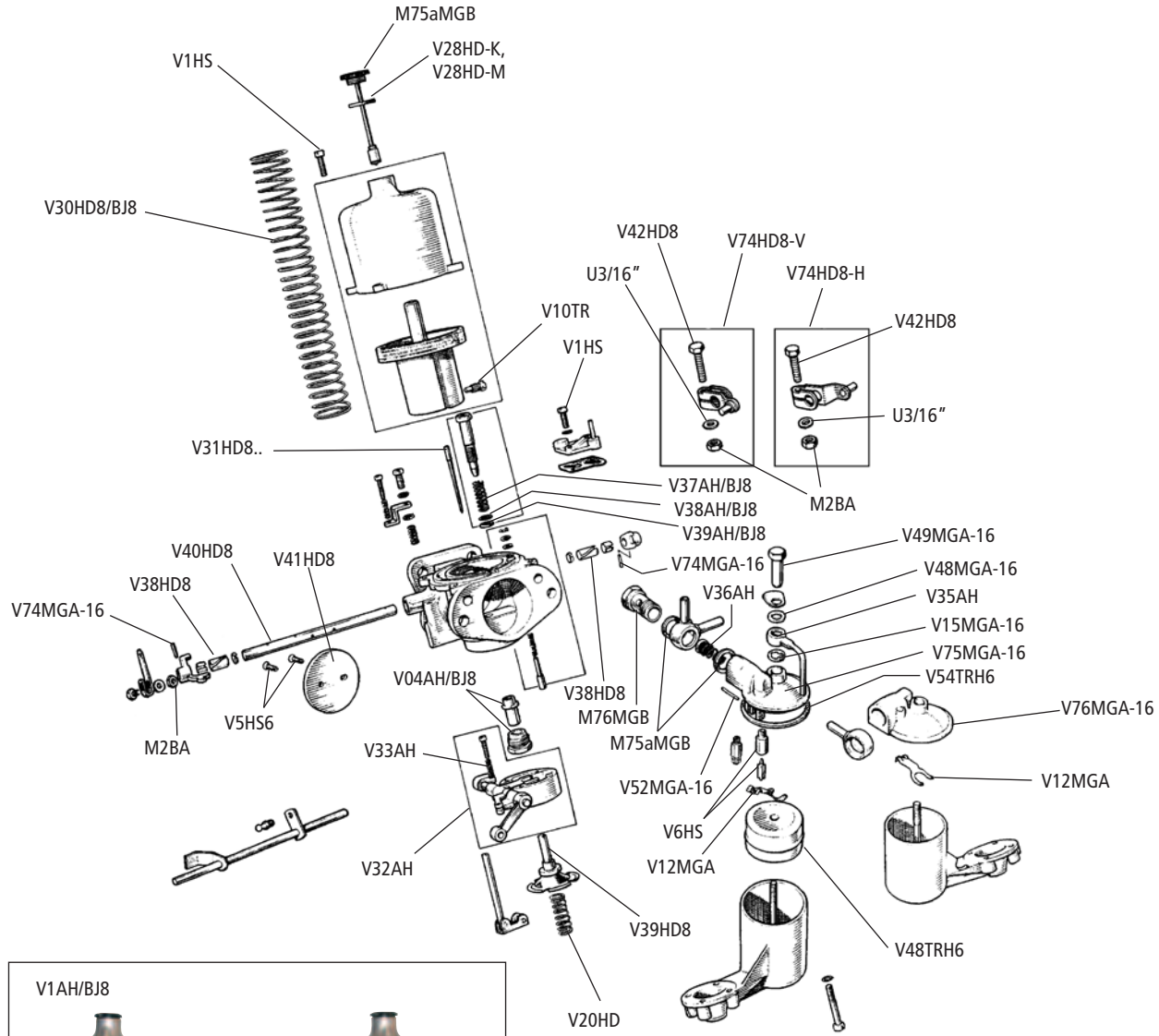

No.	Bezeichnung	Description	Type	Anzahl/Qty.
V1AH/BJ8	AT-Vergaser Paar HD8	carburettor set HD8, exchange	BJ8	1
V1HS	Schraube Schwimmerkammerdeckel	screw	BJ8	10
M2BA	Mutter 2BA	nut	BJ8	A/R
V04AH/BJ8	Lagersatz Düsenstock	jet bearing kit	BJ8	2
V5HS6	Schraube Drosselklappenwelle	screw	BJ8	4
V6HS	Schwimmernadelventil alle SU-Vergaser	needle & seat assembly	BJ8	2
V10TR	Madenschraube Düsennadel	screw, needle locking	BJ8	2
V12MGA	Vergaser-Schwimmer-Hebel	lever,hinged	BJ8	2
V15MGA-16	Dichtscheibe Schwimmerdeckel/- laufleitung	washer, fiber	BJ8	2
V20HD	Einstellteil Düsenstock	spring, jet return	BJ8	2
V28HD8-K	Vergaser-Kolben Kunststoff	cap & damper, plastic	BJ8	2
V28HD8-M	Vergaser-Kolben Messing	cap & damper, brass	BJ8	2
V30HD8/BJ8	Feder SU-Vergaser rot + grün	spring, piston return, red & green	BJ8	2
V31HD8UN	Düsennadel UN, fett	needle, rich UN	BJ8	2
V31HD8UH	Düsennadel UH, standard	needle, std. UH	BJ8	2
V31HD8UL	Düsennadel UL, mager	needle, lean UL	BJ8	2
V32AH	Leerlauf-Anschlagschraube	screw, jet adjusting	BJ8	2
V33AH	Feder Einsteller	spring	BJ8	2
V35AH	Überlaufrohr	drain pipe	BJ8	2
V36AH	Filter Schwimmerkammer	filter	BJ8	2
V37AH/BJ8	Feder	spring	BJ8	2
V38HD8	Büchse Drosselklappenwelle	bush, throttle shaft	BJ8	4
V38AH/BJ8	Unterlegscheibe	washer, cupped	BJ8	2
V39AH/BJ8	Unterlegscheibe Gummi	washer, rubber	BJ8	2
V39HD8	Düsenstock	jet assembly	BJ8	2
V40HD8	Drosselklappe vorne	shaft, throttle	BJ8	2
V41HD8	Drosselklappe	disc, throttle	BJ8	2
V42HD8	Schraube für Anschlussstück	bolt	BJ8	4
V48MGA-16	Scheibe Aluminium	washer, aluminum	BJ8	2
V48TRH6	Schwimmer (Messing)	float, brass	BJ8	2
V49MGA-16	Halteschraube Deckel Schwimmerkammer	cap nut	BJ8	2
V52MGA-16	Lagerstift Schwimmer	pin	BJ8	2
V54TRH6	Schwimmerkammerdeckeldichtung	gasket, float chamber lid	BJ8	2
V74MGA-16	Stift	pin, tapered	BJ8	4
V74HD8-V	Anschlussstück vorne	coupling, front	BJ8	1
V74HD8-H	Anschlussstück hinten	coupling, rear	BJ8	1
M75aMGB	Dichtung	washer, fiber	BJ8	A/R
V75MGA-16	Deckel Schwimmerkammer mit Heber vorne	lid, float chamber front	BJ8	1
V76MGA-16	Deckel Schwimmerkammer mit Heber hinten	lid, float chamber rear	BJ8	1
M76MGB	Schraube Banjo Anschluß	bolt, banjo	BJ8	2
V90HD8	Vergaserdichtsatz 1 Vergaser	gasket kit, for 1 carb.	BJ8	2
V91AH/HD8	Vergaser-Überhol-Satz für 1x Vergaser	master rebuild kit, for 1 carb.	BJ8	2
SU-VÖ	SU Vergaseröl 150 ml	oil, SU carb. 150 ml	BJ8	A/R

Luftfilter / Air cleaner

V75AH-V/BJ8	Luftfilter vorne (ohne Stutzen)	air cleaner, front (with connection)	BJ8	1
V75AH-H/BJ8	Luftfilter hinten (mit Stutzen)	air cleaner, rear (w/o connection)	BJ8	1
V82HD8	Isolierflansch HD8 Vergaser 2"	insulating block, heat shield to manifold	BJ8	2
V83HD8	Dichtung Flansch	gasket, heat shield to carb.	BJ8	4
V92HD8	Dichtung Vergaser-/Luftfilter	gasket, air cleaner to carb.	BJ8	2
EM122AH/BN4	Aufkleber Luftfilter	decals, air cleaners Coopers	BJ8	2

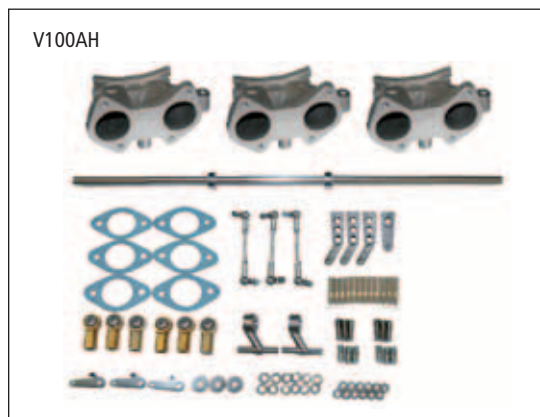
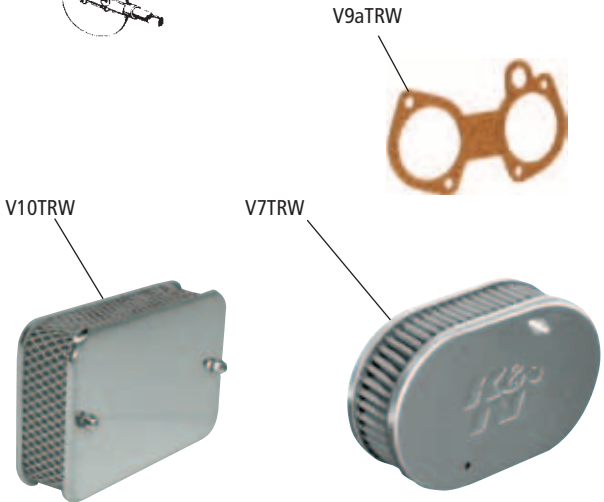
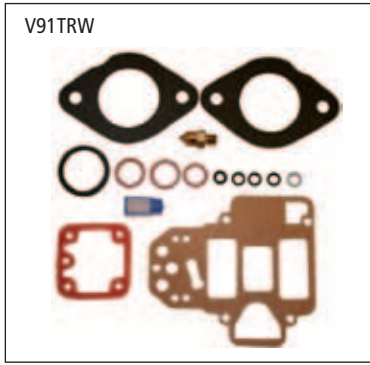
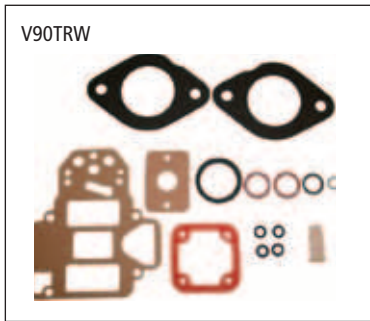
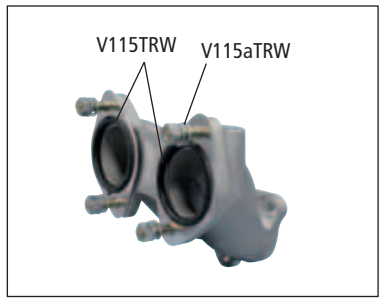
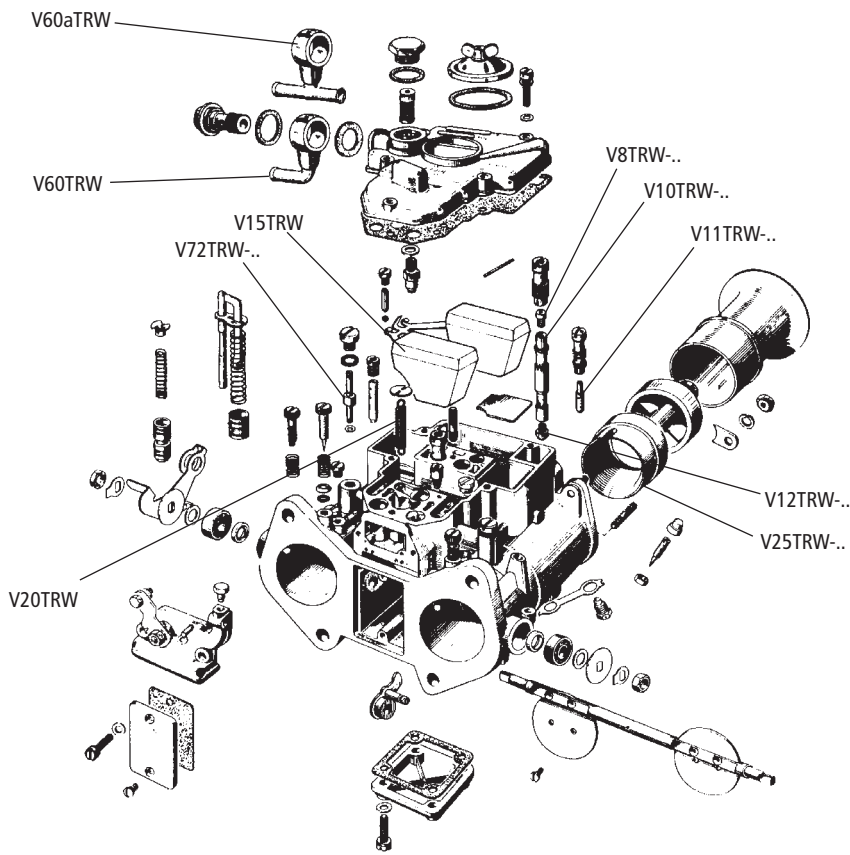

No.	Bezeichnung	Description	Type	Anzahl/Qty.
V4TRW	Vergaser Weber 45 DCOE mit Düsenbestückung	Weber DCOE45 with needles, jets	BN6, BN7, BT7, BJ7, BJ8	A/R
V5TRW/AH	Umrüstsatz bestehend aus: 1x Ansaugstutzen, 3x Vergaser DCOE, 1x Anbausatz mit Gasgestänge, 1x E/A Dichtung	conversion kit, consists of 1x inlet manifold, 3 x carburettor, linkage assembly and all fittings and manifold gasket	BN6, BN7, BT7, BJ7, BJ8	1
V7TRW	K+N Luftfilter, Bauhöhe 55mm, 40/45-er Weber	air Filter K&N, height 55 mm for DCOE 40/45	BN6, BN7, BT7, BJ7, BJ8	1
V8TRW-...	Luftkorrekturdüse (bitte Größe angeben)	air correction jet (please refer size)	BN6, BN7, BT7, BJ7, BJ8	A/R
V9aTRW	Luftfilterdichtung für V7TRW+V10TRW	Gasket air filter for V7TRW+V10TRW	BN6, BN7, BT7, BJ7, BJ8	A/R
V10TRW	Chromluftfilter f.Weber DCOE 40er und 45er	Air Filter Chrome, Weber DCOE 40/45	BN6, BN7, BT7, BJ7, BJ8	A/R
V10TRW-...	Mischrohr (bitte Bezeichnung angeben)	Emulgation tube (please refer description)	BN6, BN7, BT7, BJ7, BJ8	A/R
V11TRW-...	Leerlaufdüse (bitte Bezeichnung angeben)	Idle speed jet (please refer description)	BN6, BN7, BT7, BJ7, BJ8	A/R
V12TRW-...	Hauptdüse (bitte Größe angeben)	main jet (please refer size)	BN6, BN7, BT7, BJ7, BJ8	A/R
V15TRW	Schwimmer	float	BN6, BN7, BT7, BJ7, BJ8	A/R
V20TRW	Rückholfeder Drosselklappenwelle im Vergaser	return spring throttle shaft	BN6, BN7, BT7, BJ7, BJ8	A/R
V25TRW-...	Lufttrichter	funnel pipe	BN6, BN7, BT7, BJ7, BJ8	A/R
V60TRW	Benzinanschluss einfach	fuel pipe fitting, single	BN6, BN7, BT7, BJ7, BJ8	A/R
V60aTRW	Benzinanschluss doppelt	fuel pipe fitting, double	BN6, BN7, BT7, BJ7, BJ8	A/R
V72TRW-...	Pumpendüse (bitte Größe angeben)	pump jet (please refer size)	BN6, BN7, BT7, BJ7, BJ8	A/R
V90TRW	Vergaserdichtsatz für Weber DCOE 40/45	carburettor gasket set Weber DCOE 40/45	BN6, BN7, BT7, BJ7, BJ8	A/R
V91TRW	Vergaserreparatursatz für Weber DCOE	rebuilt kit Weber DCOE	BN6, BN7, BT7, BJ7, BJ8	A/R
V100AH	Ansaugstutzen mit Kugelgelenk-Gasgestänge und allen benötigten Befestigungsteilen für 3 x WEBER-Vergaser DCOE 45	inlet manifold, linkage assembly and all parts needed to fit 3 weber 45 DCOE included	BN6, BN7, BT7, BJ7, BJ8	1
V115TRW	O-Ring mit Metalleinlage Weber (zw. Vergaser und Ansaugbrücke)	o-ring with metal insert between Weber carburettor and inlet manifold	BN6, BN7, BT7, BJ7, BJ8	6
V115aTRW	Wellring	washer thackery	BN6, BN7, BT7, BJ7, BJ8	12

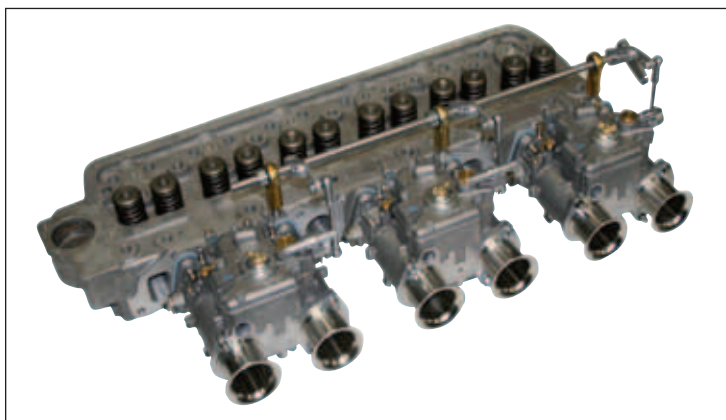

Benzintanks auch in Aluminium lieferbar !

- für BN1-BN2 Modelle
- für BN4-BJ8 Modelle
- einfache Montage

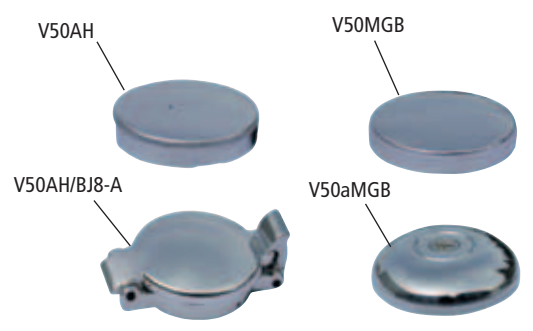
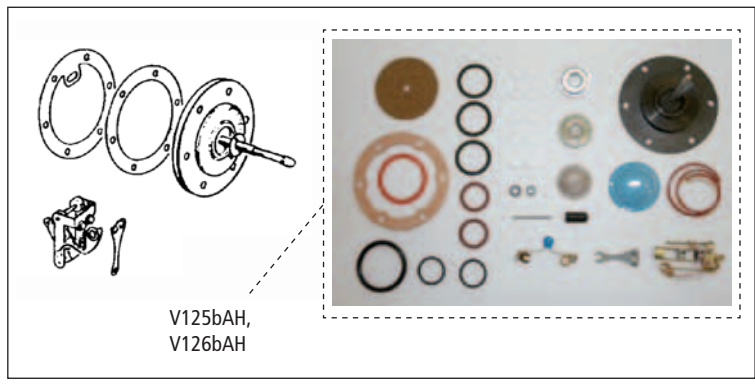
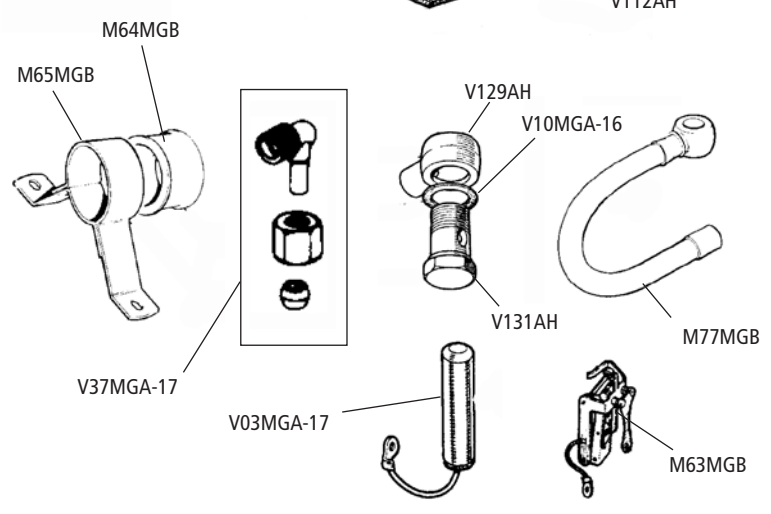
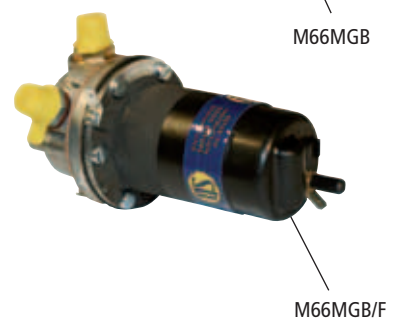
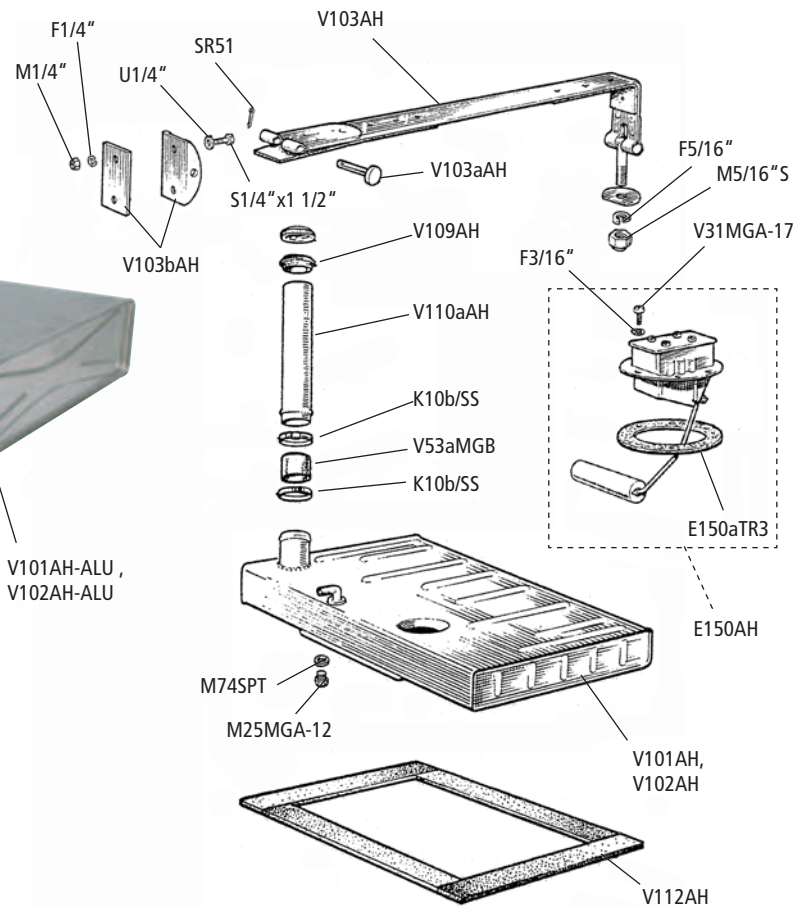

No.	Bezeichnung	Description	Type	Anzahl/Qty.
V03MGA-17	Kondensator Benzinpumpe (– an Masse)	condenser fuel pump (negative earth)	BN1-BJ8	1
V10MGA-16	Scheibe (Fiber)	washer (fibre)	BN1-BJ8	4
K10b/SS	Schelle	clamp	BN4-BJ8	2
M25MGA-12	Ablaßschraube	drain plug	BN1-BJ8	1
V31MGA-17	Schraube Tankgeber	screw tank sender unit	BN1-BJ8	6
V37MGA-17	Anschlußteil Benzinpumpe (+ an Masse)	fuel pump elbow/washer (positive earth)	BN1-BJ8	1
SR51	Splint	split pin	BN4-BJ8	2
V50AH	Tankdeckel	filler cap	BN1-BN2	1
V50AH/BJ8-A	Aston-Tankdeckel 2 1/2", abschließbar	filler cap 2 1/2", locking	BN4-BJ8	1
V50MGB	Tankdeckel	filler cap	BN4-BJ8	1
V50aMGB	Tankdeckel, abschließbar	filler cap, locking	BN4-BJ8	1
V53aMGB	Verbindung Einfüllstutzen >Tank	connection tank >filler	BN4-BJ8	1
M63MGB	Kontaktsatz Benzinpumpe	rocker and blade set fuel pump	BN1-BJ8	1
M64MGB	Gummilagerung Benzinpumpe	rubber packing fuel pump	BN1-BJ8	1
M65MGB	Halter Benzinpumpe	fuel pump bracket	BN1-BJ8	1
M66MGB	Benzinpumpe (– an Masse)	fuel pump (negative earth)	BN4>60413-BJ8	1
M66MGB/F	Benzinpumpe (+ an Masse) mit Außen- gewinde-Anschlüssen	fuel pump (positive earth) with screw on connectors	BN1-BN4<60412	1
M66aMGB	Repro-Benzinpumpe als Alternative für M66MGB	Repro fuel pump, optional replacement of no. M66MGB	BN4>60413-BJ8	1
M66bMGB/F	Repro-Benzinpumpe als Alternative für M66MGB/F	Repro fuel pump, optional replacement of no. M66MGB/F	BN1-BN4<60412	1
M74SPT	Dichtring Ablaßschraube	washer drain plug	BN1-BJ8	1
M77MGB	Benzinschlauch mit Überwurfmutter zum Anschluß an Benzinpumpe M66MGB/F	fuel hose for fuel pump no. M66MGB/F	BN1-BN4<60412	1
V101AH	Benzintank	petrol tank	BN4-BJ8	1
V101AH-ALU	Aluminium-Benzintank	aluminium-petrol tank	BN4-BJ8	1
V102AH	Benzintank	petrol tank	BN1-BN2	1
V102AH-ALU	Aluminium-Benzintank	aluminium-petrol tank	BN1-BN2	1
V103AH	Halterung Benzintank	petrol tank strap	BN4-BJ8	2
V103aAH	Lagerstift Halter Benzintank	clevis pin, for straps	BN4-BJ8	2
V103bAH	Halteplatte + Gegenplatte	bracket and plate	BN7,BT7,BJ7,BJ8	2
V109AH	Gummiring Tankdeckel/Karosserie	grommet filler cap >body	BN4-BJ8	1
V110aAH	Rohr Tankdeckel zu Benzintank	connecting pipe, filler neck >fuel tank	BN4-BJ8	1
V112AH	Gummiunterlage Benzintank	sealing rubber/fuel tank	BN4-BJ8	1
V125bAH	Reparatursatz für Benzinpumpe M66MGB (– an Masse) enthält Kontakt, Kondensator, Membrane, Ventil	repair kit to fuel pump no. M66MGB (negative earth) consists of: contact set, condenser, valve, diaphragm	BN4>60413-BJ8	1
V126bAH	Reparatursatz Benzinpumpe M66MGB/F (+ an Masse) enthält Kontakt, Kondensator, Membrane, Ventil	repair kit to fuel pump no. M66MGB/F (positive earth) consists of: contact set, con- denser, valve, diaphragm	BN1-BN4<60412	1
V129AH	Banjo-Anschluß Benzinpumpe (– an Masse)	banjo union fuel pump (negative earth)	BJ8	1
V131AH	Hohlschraube Benzinpumpe (– an Masse)	banjo union fuel pump (negative earth)	BJ8	1
V142AH	Halteclip Benzinleitung	clip, pipe to chassis	BN1-BN7	
V146AH	Original „eckige“ Benzinpumpe (+ an Masse)	orig. „square type“ fuel pump (positive earth)	BN1-BN4	1
E150AH	Tankgeber	petrol sender unit	BN1-BJ7	1
E150AH/BJ8	Tankgeber	petrol sender unit	BJ8	1
E150aTR3	Dichtscheibe Tankgeber	washer tank unit	BN1-BJ8	1

Benzinleitungen im Motorraum / fuel lines engine bay

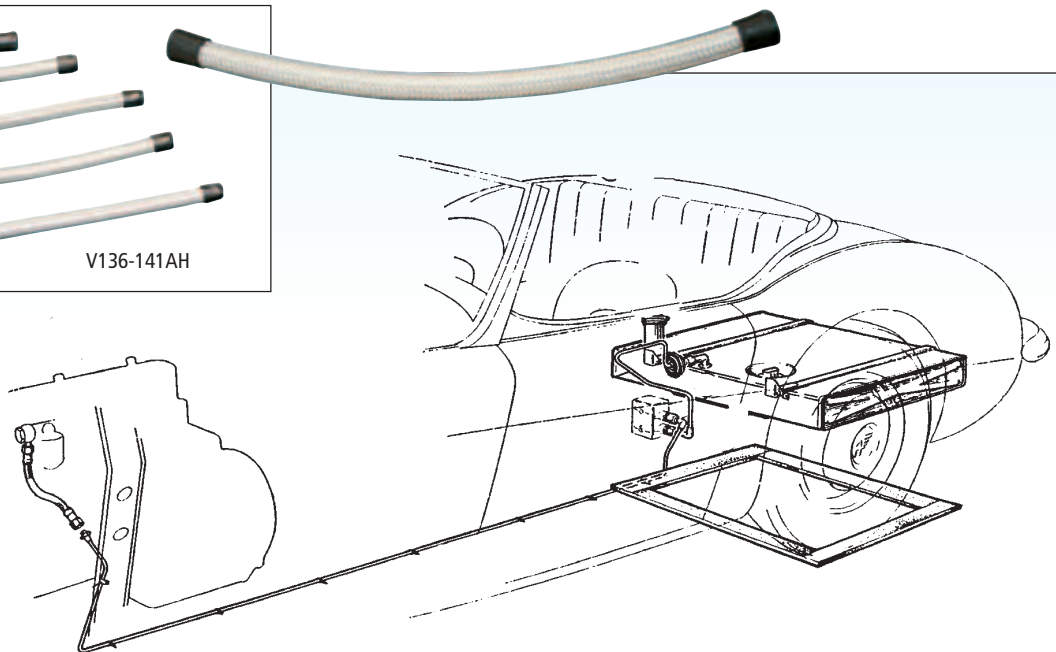
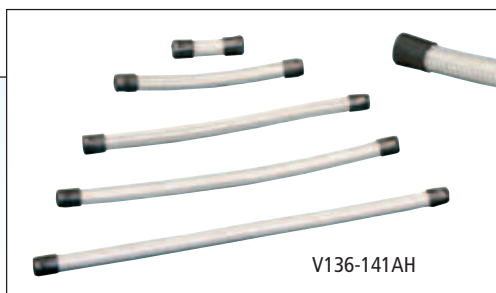
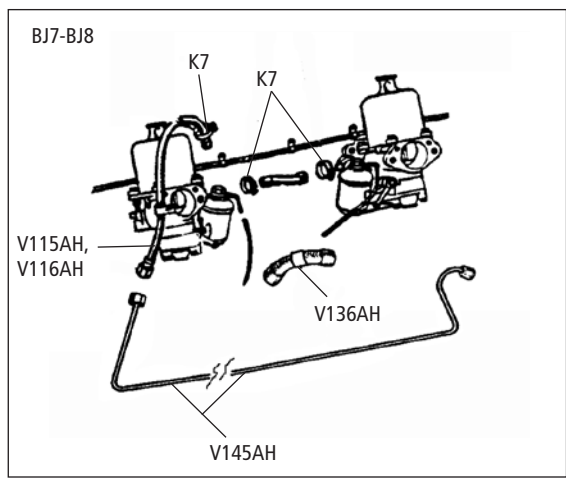
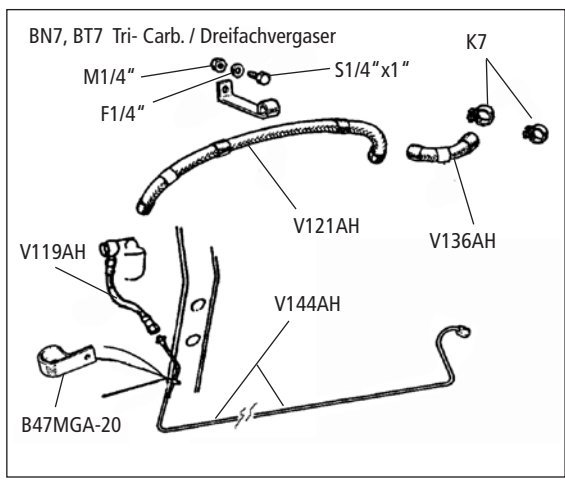
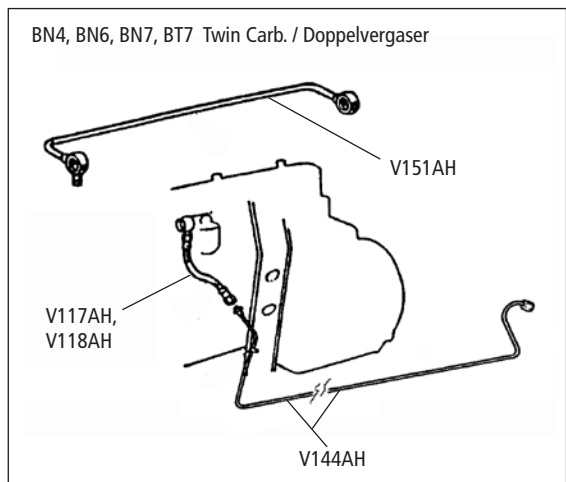
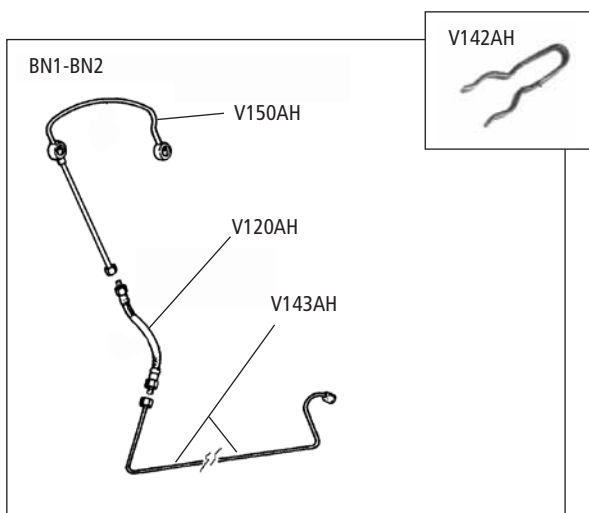

No.	Bezeichnung	Description	Type	Anzahl/Qty.
V115AH	Schlauch Benzinleitung an Vergaser	fuel hose pipe >carburettor	BJ8	1
V116AH	Schlauch Benzinleitung an Vergaser	fuel hose pipe >carburettor	BJ7	1
V117AH	Schlauch Benzinleitung an Vergaser	fuel hose pipe >carburettor	BN4>58727,BN6,BN7,BT7<29e101	1
V118AH	Schlauch Benzinleitung an Vergaser	fuel hose pipe >carburettor	BN4<58726	1
V119AH	Schlauch Benzinleitung an Vergaser	fuel hose pipe >carburettor	BN7-BT7>29e101	1
V120AH	Schlauch Benzinleitung an Vergaser	fuel hose pipe >carburettor	BN1-BN2	1
V121AH	Schlauch Vergaser vorne/Mitte	fuel hose front >centre carburettor	BN7-BT7 (3-fach Verg./Tri-carb.)	1
V136AH	Schlauch zwischen beiden Vergasern oder Schlauch Vergaser Mitte/hinten	fuel hose between carburettors or fuel hose centre >rear carburettor	BJ7-BJ8 BN7-BT7 (3-fach Verg./Tri-carb)	1
	Benzin Schlauch metallumwebt:	fuel hose braided:		
V136AH	mit Gummi-Endkappen (6 cm)	with rubber end caps (6 cm)	BN1-BJ8	1
V137AH	mit Gummi-Endkappen (12 cm)	with rubber end caps (12 cm)	BN1-BJ8	1
V138AH	mit Gummi-Endkappen (18 cm)	with rubber end caps (18 cm)	BN1-BJ8	1
V139AH	mit Gummi-Endkappen (30 cm)	with rubber end caps (30 cm)	BN1-BJ8	1
V140AH	mit Gummi-Endkappen (36 cm)	with rubber end caps (36 cm)	BN1-BJ8	1
V141AH	mit Gummi-Endkappen (56 cm)	with rubber end caps (56 cm)	BN1-BJ8	1
V142AH	Befestigungsclip Benzinleitungen	fixing clip fuel pipes	BN1-BN7	A/R
V141aAH	Gummi Endkappe Benzinschlauch	rubber end cap fuel hose	BN1-BJ8	A/R
V132aAH	Klemmkeil/Mutter Benzinleitung	wedge/nut fuel pipe	BN1-BN2	A/R
	Benzinleitungen BN1-BN2	Fuel lines BN1-BN2		
V120AH	Schlauch Benzinleitung an Vergaser	fuel hose pipe >carburettor	BN1-BN2	1
V143AH	Benzinleitungssatz Kupfer, 2-teilig	copper fuel pipes, set (2 pcs.)	BN1-BN2	1
V150AH	Benzinleitung Vergaser zu Vergaser	fuel hose connector carburettor to carburettor	BN1-BN2	1
	Benzinleitungen BN4, BN6, BN7, BT7	Fuel lines BN4, BN6, BN7, BT7		
V117AH	Schlauch Benzinleitung an Vergaser	fuel hose pipe >carburettor	BN4>58727,BN6,BN7,BT7	1
V118AH	Schlauch Benzinleitung an Vergaser	fuel hose pipe >carburettor	BN4<58726	1
V144AH	Benzinleitungssatz Kupfer, 2-teilig	copper fuel pipes, set (2 pcs.)	BN4-BT7	1
V151AH	Benzinleitung Vergaser zu Vergaser	fuel hose connector carburettor to carburettor	BN4>48863,BN6,BN7, BT7<29D-H26212	1
	Benzinleitungen BN7, BT7 3-fach Vergaser	Fuel lines BN7, BT7 Tri-Carb.		
K7	Schlauchschelle	clip wire	BN7, BT7	5
B47MGA-20	Leitungsklammer 5/16"	clip, pipe	BN7, BT7	5
V121AH	Benzinschlauch vorne	fuel hose front	BN7, BT7	1
V136AH	Benzinschlauch Mitte/hinten	fuel hose centre/rear	BN7, BT7	2
V144AH	Benzinleitungssatz Kupfer, 2-teilig	copper fuel pipes, set (2 pcs.)	BN7, BT7	1
	Benzinleitungen BJ7-BJ8	Fuel lines BJ7, BJ8		
K7	Schlauchschelle	clip wire	BJ7-BJ8	2
V115AH	Schlauch Benzinleitung an Vergaser	fuel hose pipe >carburettor	BJ8	1
V116AH	Schlauch Benzinleitung an Vergaser	fuel hose pipe >carburettor	BJ7	1
V136AH	Benzinschlauch	fuel hose	BJ7-BJ8	1
V145AH	Benzinleitungssatz Kupfer, 2-teilig	copper fuel pipes, set (2 pcs.)	BJ7-BJ8	1

BJ7, BJ8 (LHD,RHD)

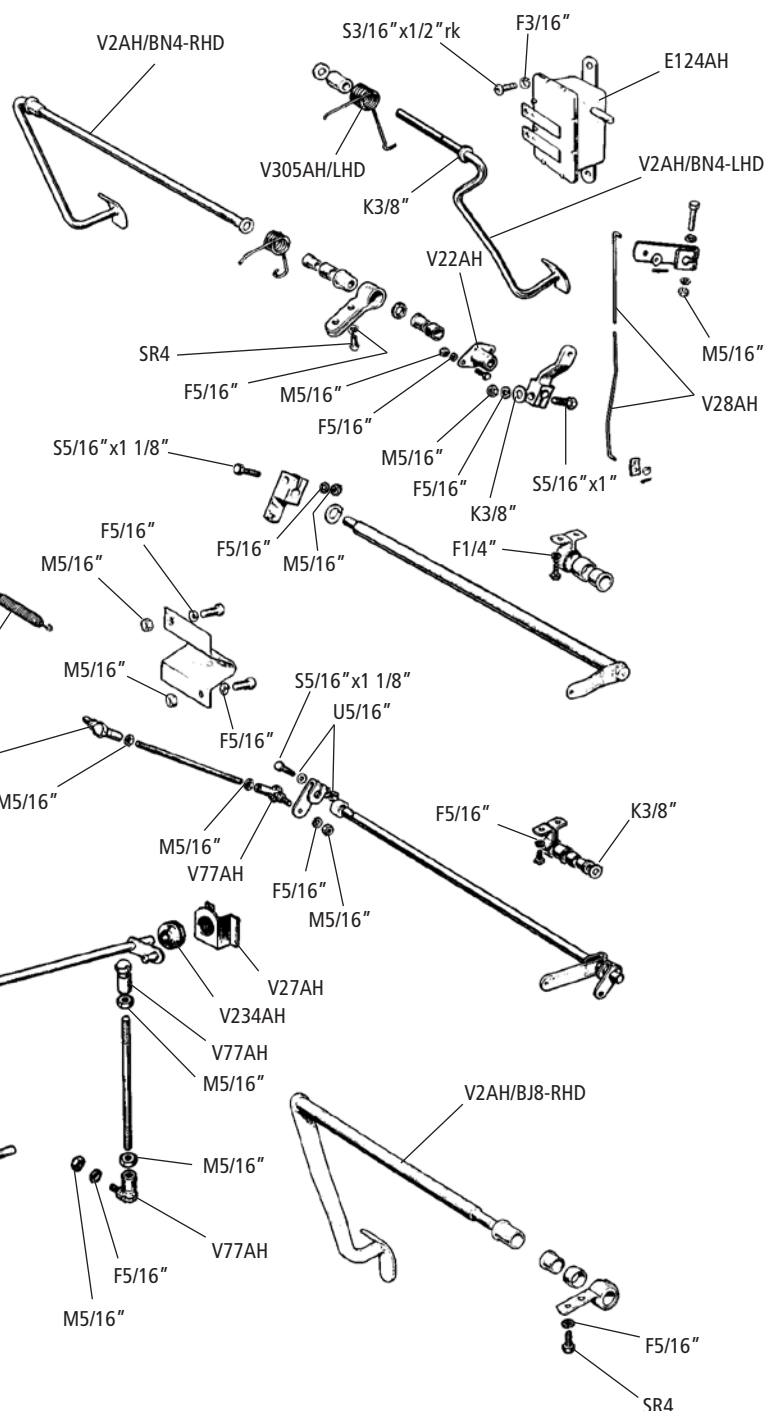
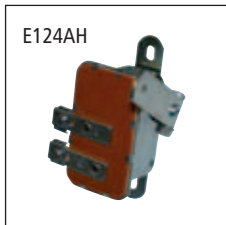
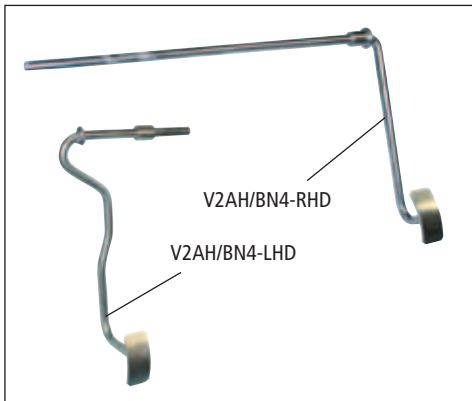

Gaszug / Accelerator BJ7, BJ8 (LHD, RHD)

No.	Bezeichnung	Description	Type	Anzahl/Qty.
V2AH/BN4-LHD	Gaspedal LHD	accelerator pedal & shaft, LHD	BJ7, BJ8	1
V2AH/BN4-RHD	Gaspedal RHD	accelerator pedal & shaft, RHD	BJ7	1
V2AH/BJ8-RHD	Gaspedal RHD	accelerator pedal & shaft, RHD	BJ8	1
SR4	Rundkopfschraube 1/4" x 1" UNF	screw	BJ7, BJ8	2
V22AH	Führung Gaspedal	cup, for bush	BJ7, BJ8	1
V23AH	Nylonlager Gasgestänge/Krümmter	bracket, relay shaft, nylon	BJ7, BJ8	1
V25AH	Halter Starterzug	bracket, reinforcement	BJ7, BJ8	1
V26AH	Halter Verstärkung	bracket, reinforcement	BJ7, BJ8	1
V27AH	Gehäuse Buchse Gasgestänge	bracket, relay shaft bearing	BJ7, BJ8	1
V28AH	Verbindung Drosselklappenwelle	link, throttle switch	BJ7, BJ8	1
B47MGA-20	Klammer 8mm x 5mm	clip, 8mm x 5mm	BJ7, BJ8	1
V71HS	Vergaser-Rückholfeder	spring, throttle return	BJ7, BJ8	2
V77AH	Kugelgelenk Gasgestänge	ball joint, for rod	BJ7, BJ8	A/R
V75AH	Hebel Welle	lever, accelerator spindle	BJ7, BJ8	1
E124AH	Kickdown-Schalter Overdrive	throttle switch	BJ7, BJ8	1
V234AH	Lagerbuchse Gestänge/Spritzwand	bearing, relay shaft, in dash	BJ7, BJ8	1
V305AH/LHD	Rückholfeder Gaspedal LHD	spring, pedal return LHD	BJ7, BJ8	1
V306bAH	Halter Vergaser-Rückholfeder	bracket	BJ7, BJ8	1
K3/8"	Karoseriescheibe 3/8"	washer, plain	BJ7, BJ8	A/R

Chokeyzug/ Choke Cable BJ7, BJ8 (LHD, RHD)

W15	Nippel, Chokey/Heizungszug	trunion & screw	BJ7	2
V37MGA-16	Befestigung Gaszug	cable stop	BJ8	2
V111AH/BJ8	Umrüstsatz Gasgestänge zu Gaszug	throttle cable conversion	BJ7, BJ8	1
V128AH/BJ8-RH	Haupt-Chokeyzug RHD	choke cable RHD	BJ7, BJ8	1
V128AH/BJ8-LH	Haupt-Chokeyzug LHD	choke cable LHD	BJ7, BJ8	1
V128aAH/BJ8-V	Chokeyzug vorne	choke cable, front carb.	BJ7, BJ8	1
V128aAH/BJ8-H	Chokeyzug hinten	choke cable, rear carb.	BJ7, BJ8	1
V130AH/BJ8	Halter Chokeyzug	bracket, choke cable	BJ8	2
V132AH	Gelenkstift Chokeyzug	cable stop, cable to block	BJ7, BJ8	1
V133AH	Halter Starterzug	body, choke control	BJ7, BJ8	1
V134AH	Halteblock Chokeyzug	block, remote control cable	BJ7, BJ8	1

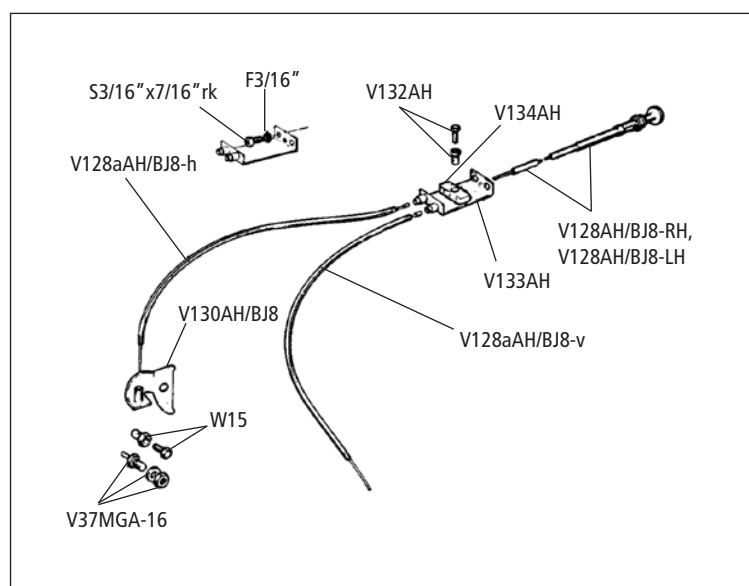

Gas- und Chokeyzug:

- BN7, BT7 Tri Carburettor auf Seite 58-59
- BN4, BN6, BN7, BT7 Twin Carburettor auf Seite 60-61
- BN1-BN2 auf Seite 62

Accelerator & choke control:

- BN7, BT7 Tri Carburettor on page 58-59
- BN4, BN6, BN7, BT7 Twin Carburettor on page 60-61
- BN1-BN2 on page 62

Abb. RHD / fig. RHD illustrated – Tri Carb BN7, BT7

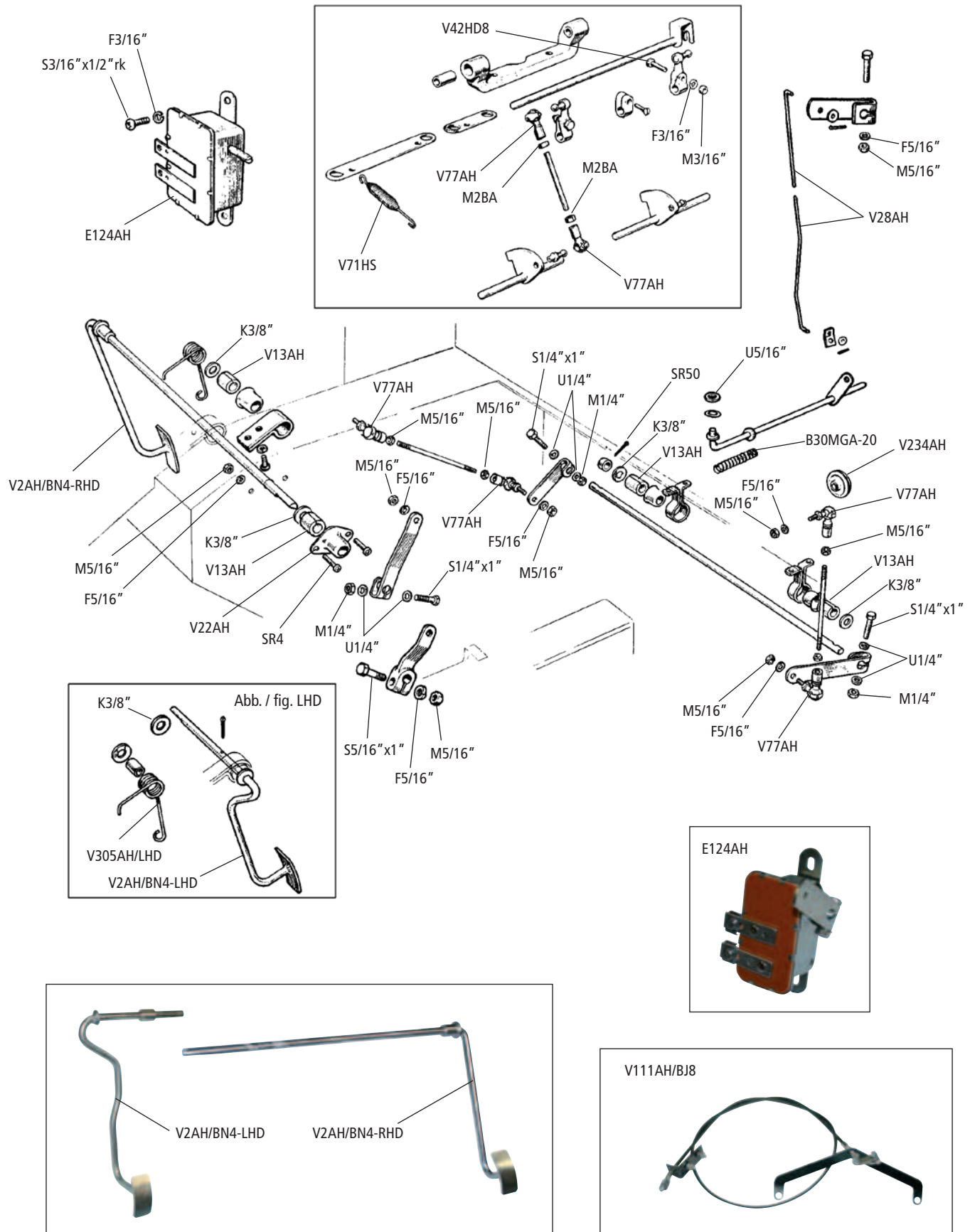

Gaszug / Accelerator Tri Carb BN7, BT7 (LHD, RHD)

No.	Bezeichnung	Description	Type	Anzahl/Qty.
V2AH/BN4-LHD	Gaspedal LHD	accelerator pedal & shaft, LHD	BN7, BT7	1
V2AH/BN4-RHD	Gaspedal RHD	accelerator pedal & shaft, RHD	BN7, BT7	1
M2BA	Mutter 2BA	nut 2BA	BN7, BT7	4
SR4	Rundkopfschraube 1/4" x 1" UNF	screw, cup to pedal box	BN7, BT7	A/R
V13AH	Hülse Gaspedal	bush	BN7, BT7	A/R
V22AH	Führung Gaspedal	cup, for bush	BN7, BT7	1
V28AH	Verbindung Drosselklappenwelle	link, throttle switch	BN7, BT7	1
B30MGA-20	Feder	spring	BN7, BT7	1
V42HD8	Schraube für Anschlussstück	bolt	BN7, BT7	2
SR50	Splint LHD	cotter pin	BN7, BT7	1
V71HS	Vergaser-Rückholfeder	spring, throttle return	BN7, BT7	2
V77AH	Kugelgelenk Gasgestänge	ball joint, for rod	BN7, BT7	A/R
E124AH	Kickdown-Schalter Overdrive	throttle switch	BN7, BT7	1
V234AH	Lagerbuchse Gestänge/Spritzwand	bearing, relay shaft, in bulkhead	BN7, BT7	1
V305AH/LHD	Rückholfeder Gaspedal LHD	spring, pedal return	BN7, BT7	1
K3/8"	Karoseriescheibe 3/8"	washer 3/8"	BN7, BT7	A/R

Chokeyzug/ Choke Cable Tri Carb BN7, BT7 (LHD, RHD)

W15	Nippel, Chokey/Heizungszug	cable stop	BN7, BT7	4
V43MGA-16	Halter Gaszug	abutment, cable	BN7, BT7	1
V111AH/BJ8	Umrüstsatz Gasgestänge zu Gaszug	throttle cable conversion	BN7, BT7	1
V128AH/BN4	Haupt-Chokeyzug	choke cable	BN7, BT7	1
V128aAH/BT7-v	Chokeyzug vorne	choke cable, front	BN7, BT7	1
V128aAH/BT7-m	Chokeyzug mitte	choke cable, center	BN7, BT7	1
V128aAH/BT7-h	Chokeyzug hinten	choke cable, rear	BN7, BT7	1
RT3/4"	Tülle Chokeyzug/Gaszug Bohrungs-Ø 19mm	grommet, choke cable	BN7, BT7	1



Abb. RHD / fig. RHD illustrated – Twin Carb BN4, BN6, BN7, BT7



Gaszug / Accelerator Twin Carb BN4, BN6, BN7, BT7

No.	Bezeichnung	Description	Type	Anzahl/Qty.
V2AH/BN4-LHD	Gaspedal LHD	accelerator pedal & shaft, LHD	BN4,BN6,BN7, BT7	1
V2AH/BN4-RHD	Gaspedal RHD	accelerator pedal & shaft, RHD	BN4,BN6,BN7, BT7	1
SR4	Rundkopfschraube 1/4" x 1" UNF	screw	BN7, BT7	2
V6TR	Doppelfeder	coupling assembly	BN4<48862	1
V13AH	Hülse Gaspedal	bush, felt	BN4,BN6,BN7, BT7	A/R
V22AH	Führung Gaspedal	cup, for bush	BN4,BN6,BN7, BT7	1
V23AH	Nylonlager	bracket, relay shaft, nylon	BN4>48863,BN6,BN7,BT7	1
ZK51MGA-09	Klammer Bolzen	circlip, for relay shaft	BN6,BN7, BT7	2
V62MGA-16	Schraube	bolt	BN4<48862	1
V77MGA-16	Feststellmutter Gasgestänge 4B A	nut	BN4<48862	1
V77AH	Kugelgelenk Gasgestänge	ball joint, for rod	BN4,BN6,BN7, BT7	6
E124AH	Kickdown-Schalter Overdrive	throttle switch	BN4,BN6,BN7, BT7	1
V234AH	Lagerbuchse	bearing, relay shaft, in bulkhead	BN4,BN6,BN7, BT7	1
V305AH/LHD	Rückholfeder Gaspedal LHD	spring, pedal return	BN4,BN6,BN7, BT7	1
K3/8"	Karoseriescheibe 3/8"	washer	BN4,BN6,BN7, BT7	A/R

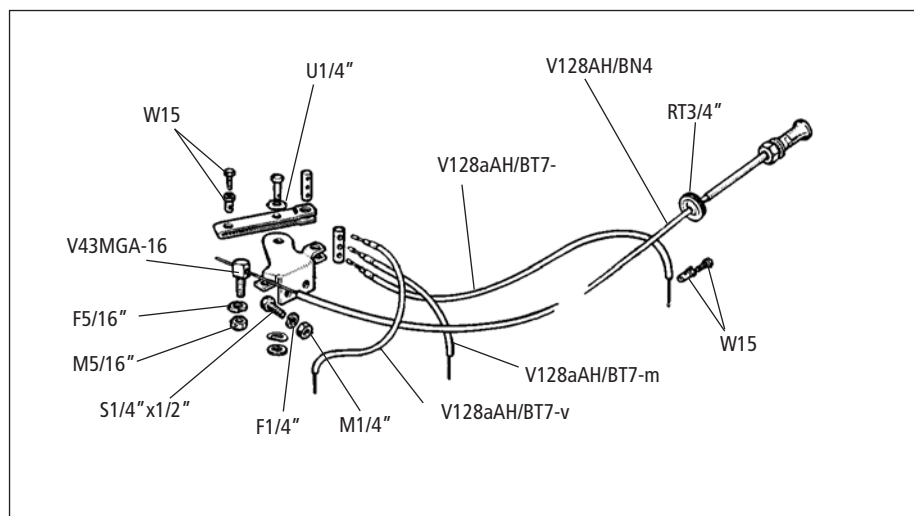
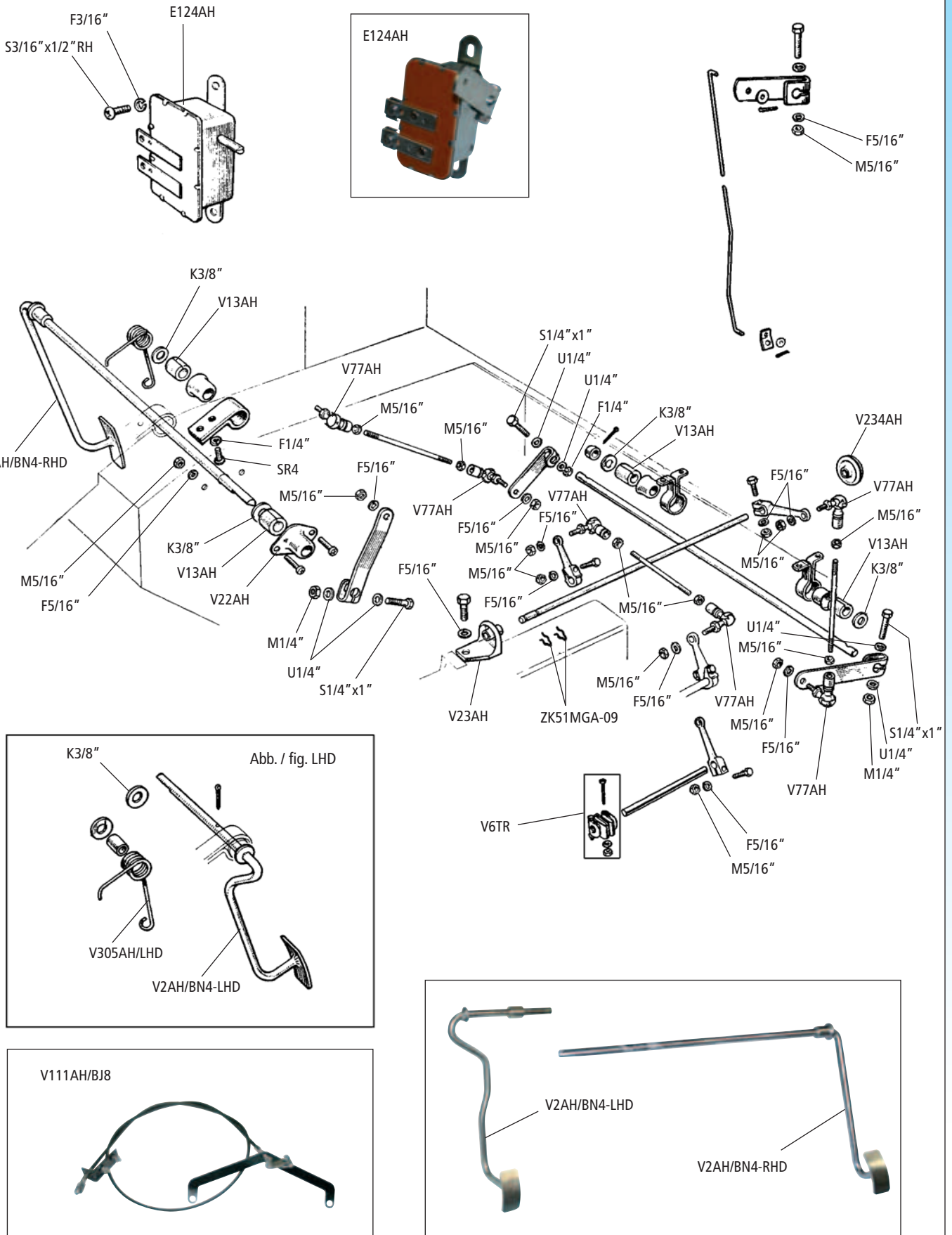
Chokeyzug / Choke Cable Twin Carb BN4, BN6, BN7, BT7

W15	Nippel, Chokey/Heizungszug	trunnion & screw	BN4<48862	2
V24AH	Einstellstift	pin, abutment, for outer cable	BN4<48862	1
V24aAH	Endstück Einstellstift	distance piece, for pin	BN4<48862	1
V92HD8	Dichtung Vergaser-/Luftfilter	gasket carb/air cleaner	BN6,BN7,BT7<2193,BN7>5234, BT7>5310	1
V111AH/BJ8	Umrüstsatz Gasgestänge zu Gaszug	throttle cable conversion	BN4,BN6,BN7, BT7	1
V126AH	Verbindungsbügel	stirrup, for connecting jet levers	BN4<48862	1
V127AH	Befestigungssatz Chokey	trunnion assembly	BN4>48863, BN6,BN7,BT7<2193	1
V128AH/BN4	Haupt-Chokeyzug	choke cable	BN4,BN6,BN7, BT7	1
V130AH/BN4	Halter Chokey (HD6)	bracket, choke cable	BN4<48862,BN6,BN7,BT7<2193,BN7 >5234,BT7>5310	1
RT3/4"	Tülle Ø 19mm 3/4"x3/16"	grommet, choke cable	BN6, BN7&BT7<2193, BN7>5234, BT7>5310	1

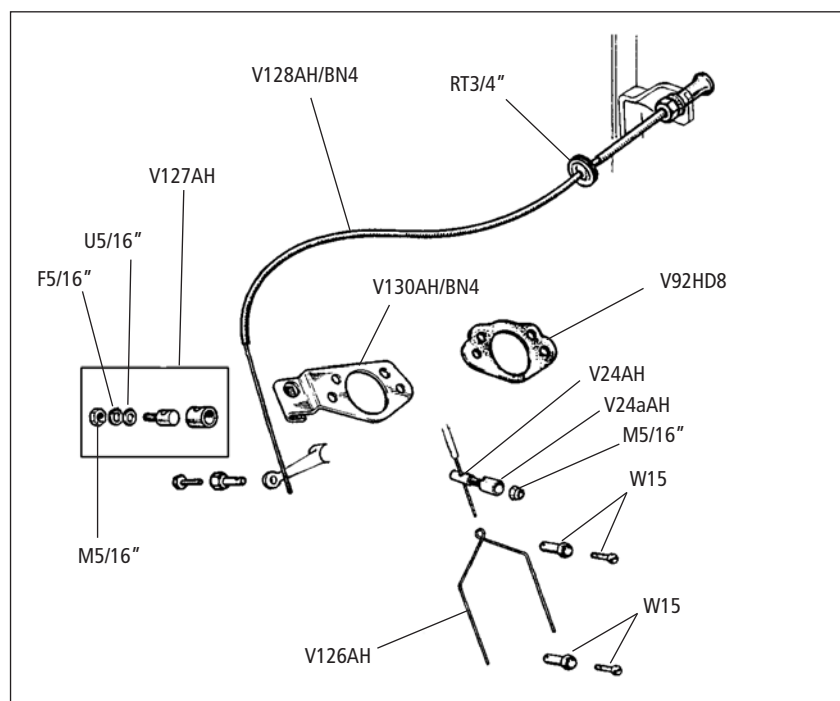

Gaszug / Accelerator BN1, BN2 (LHD + RHD)

No.	Bezeichnung	Description	Type	Anzahl/Qty.
V2AH/BN1-LHD	Gaspedal LHD	accelerator pedal & shaft, LHD	BN1, BN2	1
V2AH/BN1-RHD	Gaspedal RHD	accelerator pedal & shaft, RHD	BN1, BN2	1
M2BA	Mutter 2BA	nut 2BA	BN1<223383	A/R
M3/16"	Mutter 3/16"	nut 3/16"	BN1>223384, BN2	A/R
V3AH	Halter Gaspedalstange RHD/LHD	bracket, for shaft RHD/LHD	BN1, BN2	1
V77AH/BN1	Kugelgelenk Gasgestänge	ball joint, for rod	BN1<223383	6
V77AH	Kugelgelenk Gasgestänge	ball joint, for rod	BN1>223384, BN2	6
E124AH	Kickdown-Schalter Overdrive	throttle switch	BN1, BN2	1

Chokezug/ Choke Cable BN1, BN2 (LHD + RHD)

W15	Nippel, Choke/Heizungszug	trunion & screw	BN1, BN2	3
V111AH/BN1	Umrüstsatz Gasgestänge zu Gaszug	throttle cable conversion	BN1, BN2	1
V124AH	Halter Choke hinten	bracket, choke cable abutment	BN1, BN2	1
V125AH	Pin + Mutter für Chokekabel	pin & nut, abutment for outer cable	BN1, BN2	1
V126AH	Verbindungsbügel	stirrup, for connecting jet levers	BN1, BN2	1
V128AH	Haupt-Chokezug	choke cable	BN1, BN2	1
V130AH	Halter Choke vorne	bracket, choke cable to parcel shelf	BN1, BN2	1
RT3/4"	Tülle Chokezug/Gaszug Bohrungs-Ø 19mm	grommet, choke cable	BN1, BN2	1

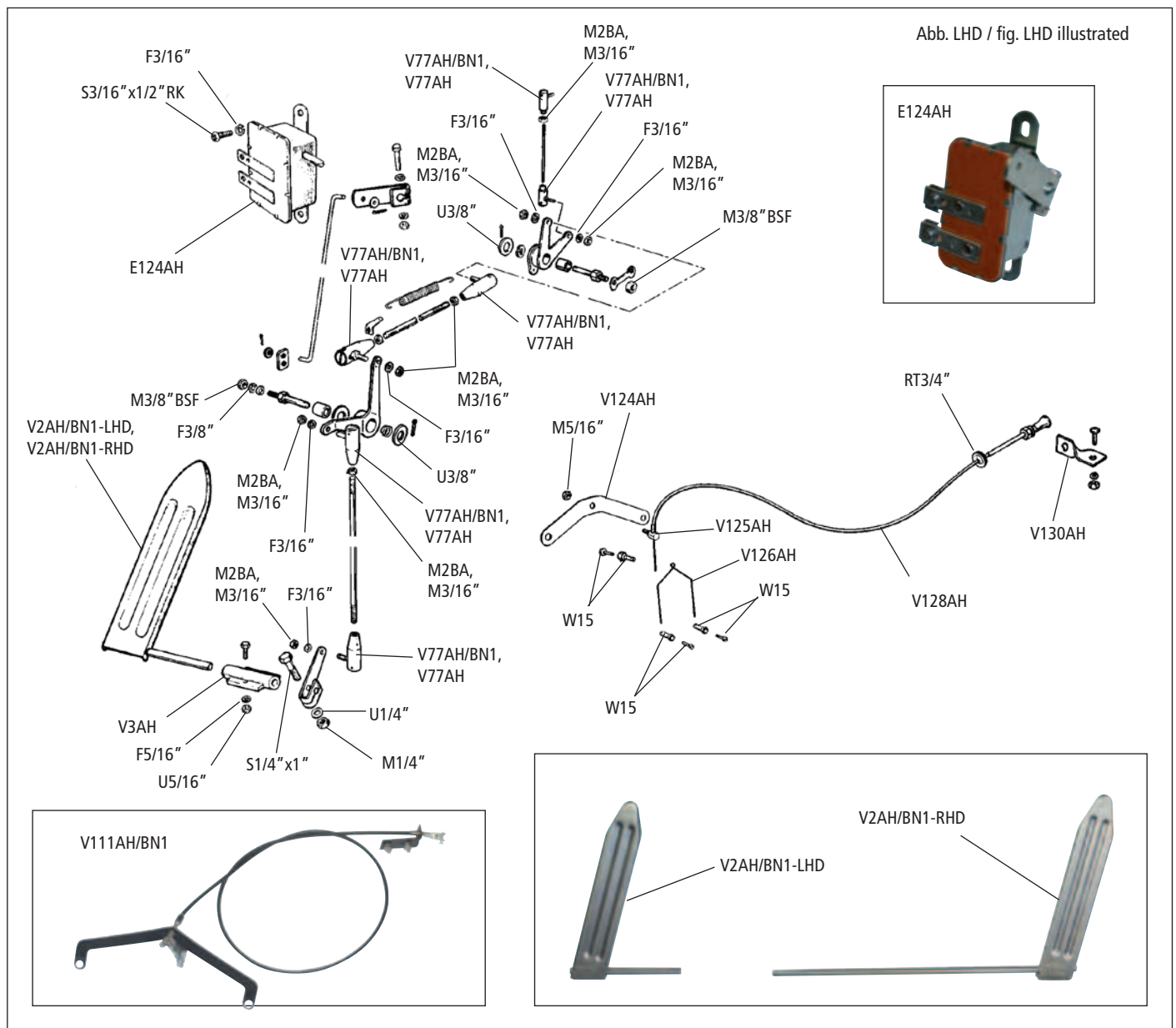

Heizung / Heater Assembly BN1-BN2 (100-4)

No.	Bezeichnung	Description	Type	Anzahl/Qty.
K22TR3	Netz Heizungskühler	radiator assembly	BN1-BN2	1
K50AH	Heizung	heater assembly	BN1-BN2	1
K60AH	Heizungs-Regelschalter für gesteckten Bedienungsknopf	switch, rheostat	BN1-BN2	1
K60aAH	Knopf Heizungsschalter, gesteckt	knob, push-on	BN1-BN2	1
K61AH	Knopf Heizungsschalter, durch Schraube gesichert	knob, screw retained	BN1-BN2	1
K61aAH	Schraube zu K61AH	screw, knob, to no. K61AH	BN1-BN2	1

Wasserschläuche, Heizungsventil / Water Pipes and Control Valve

G08MGB-09	Fiberscheibe	washer, fiber	BN1-BN2	A/R
K19AH	Heizungshahn Wasserpumpe	heater tap, on water pump	BN1-BN2	1
K20AH	Schlauch Heizhahn	hose, return pipe to heater tap	BN1-BN2	1
M21AH/BN1	Heizungsventil	heater valve, on cylinder head	BN1-BN2	1
K52AH/BN1	Wasserrohr Heizung	return pipe, copper	BN1-BN2	1
K127AH	Schlauch-Schelle	clip, water hoses	BN1-BN2	6

Lüftungsschlitze / Hot Air Outlets

EM1aTR	Halteclip	nut, spire	BN1-BN2	6
K23MGA-32	Schlauch-Schelle	clip, hose	BN1-BN2	4
K37AH	Schlauch 14"	hose 14"	BN1-BN2	1
K37aAH	Schlauch 12"	hose 12"	BN1-BN2	1
i505AH	Blende Lüftungsschlitze zur Scheibe	mask assembly, demister outlet	BN1-BN2	2
i505AH/C	Blende Lüftungsschlitze chrom zur Scheibe	mask assembly, demister outlet, chrome	BN1-BN2	2

Frischluftsystem / Fresh Air System

V02MGA-14	Klammer Schlauch	clamp, hose to wheelarch	BN1-BN2	1
K15AH	Frischluftschlauch 81 cm	hose 81 cm	BN1-BN2	1
K15bAH/BN1	Lufteinlass + Klappe	valve assembly, fresh air	BN1-BN2	1
K15bAH	Netz Lufteinlass	gauze, fresh air valve	BN1-BN2	1
W15TR4	Heizungszug	cable, fresh air control	BN1-BN2	1
KA21AH	Kaltluft Regulierknopf	knob, fresh air control cable	BN1-BN2	1
K23MGA-32	Schlauch-Schelle 4"	clip 4"	BN1-BN2	1
R240AH	Stopfen Getriebetunnel	plug, in scuttle, fresh air inlet	BN1-BN2	1
RT3/4"	Tülle Ø 19mm	grommet Ø 19mm	BN1-BN2	1

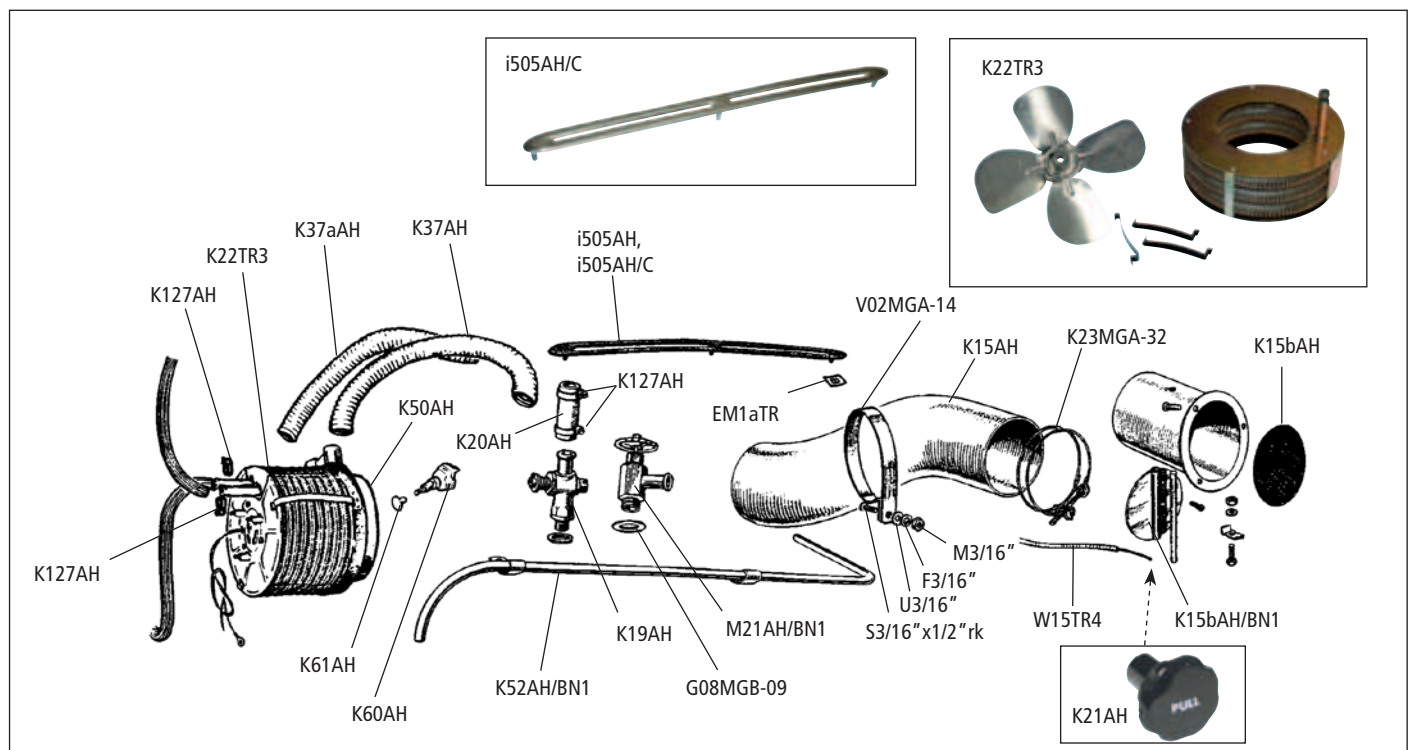

BN4, BN6, BN7, BT7, BJ7, BJ8 (100-6, 3000)

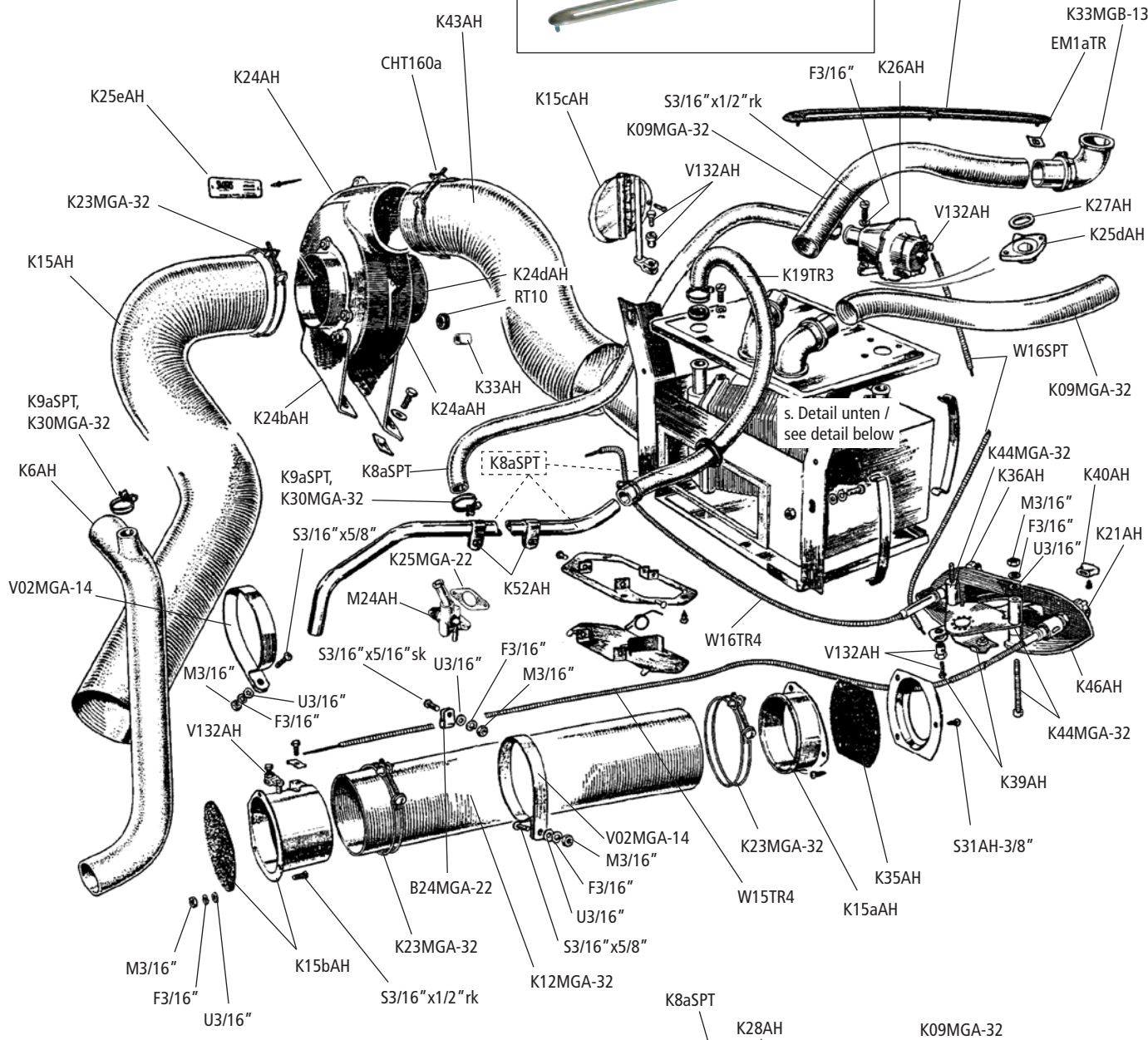

s. Detail unten / see detail below

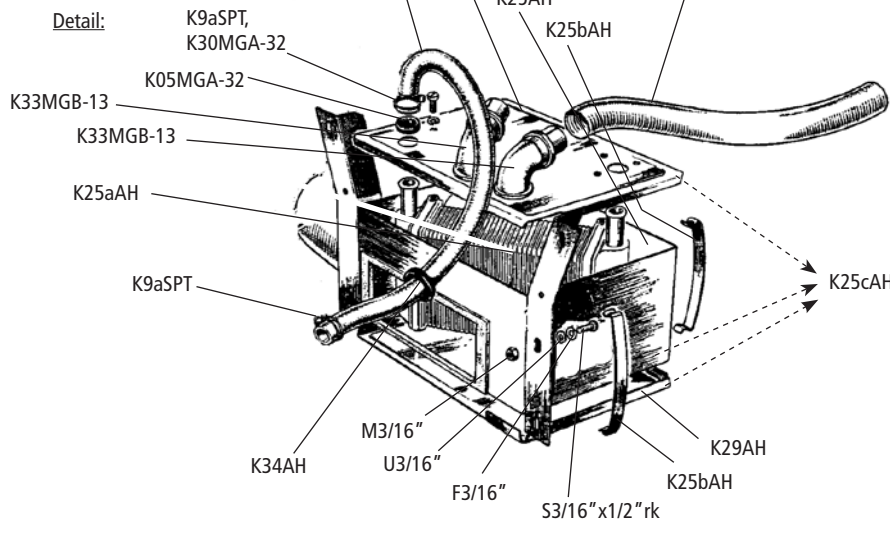

Heizung / Heater Assembly BN4, BN6, BN7, BT7, BJ7, BJ8 (100-6, 3000)

No.	Bezeichnung	Description	Type	Anzahl/Qty.
K15cAH	Gummi-Dichtung Lufteinlass vorne	seal, air inlet	BN4-BJ8	1
K25AH	Heizung komplett	heater assembly	BN4-BJ8	1
K25aAH	Heizungskühler	radiator	BN4-BJ8	1
K25bAH	Klammer Heizungsgehäuse	clip, spring	BN4-BJ8	3
K25cAH	Gehäuse Heizung	heater unit case, complete	BN4-BJ8	1
K28AH	Deckel Gehäuse Heizung	heater box, top	BN4-BJ8	1
K29AH	Gehäuseboden Heizung	heater box, bottom	BN4-BJ8	1
S31AH-3/8	Schraube selbstschneidend	screw	BN4-BJ8	11

Wasserschläuche, Heizungsventil / Water Pipes and Control Valve

K05MGA-32	Dichtung Heizung zu Karroserie	grommet, heater box	BN4-BJ8	1
K6AH	Kühler-Schlauch unten	radiator hose bottom	BN4-BJ8	1
K8aSPT	Schlauch	hose	BN4-BJ8	1+1
K9aSPT	Schlauchschnelle 16-27mm	clip 16-27mm	BN4-BJ8	4
K19TR3	Heizungsschlauch Innenraum	heating hose	BN4-BJ8	1
M24AH	Heizungsabsperrventil a. Motor	heater control tap (on engine)	BN4-BJ8	1
K25MGA-32	Dichtung	gasket	BN4-BJ8	1
K25dAH	Adapter/Verbinder Heizventil	adaptor, heater valve	BN4-BJ8	1
K26AH	Heizungsventil	heater control valve	BN4-BJ8	1
K27AH	Dichtring Heizungsventil	O ring	BN4-BJ8	1
K30MGA-32	Drahtschelle 9/16 - 3/4"	clip 9/16 - 3/4", wire type	BN4-BJ8	4
K34AH	Dichtgummi	grommet, bulkhead	BN4-BJ8	2
K52AH	Wasserrohr Heizung	pipe, water return	BN4-BJ8	1

Frischlufzufuhr zur Heizung / Cool Air to Heater

V02MGA-14	Klammer Schlauch	clamp	BN4-BJ8	2
RT10	Gummiunterlage Heizungsgebläse	grommet, blower mounting	BN4-BJ8	4
K15AH	Frischlufschlauch 81cm	hose 81cm	BN4-BJ8	1
K23MGA-32	Schlauch-Schnelle 4"	clip 4"	BN4-BJ8	3+3
K24AH	Heizgebläse	blower assembly	BN4-BJ8	1
K24aAH	Gehäuse Heizgebläse	casing	BN4-BJ8	1
K24bAH	Halter Heizgebläse	bracket, blower	BN4-BJ8	2
K24dAH	Motor Heizgebläse	motor	BN4-BJ8	1
K25eAH	Schild „Smiths heater“	name plate, SMITHS	BN4-BJ8	1
K33AH	Abstandsbuchse	spacer	BN4-BJ8	4
K43AH	Schlauch Gebläse zur Heizung 3 1/4"	hose 3 1/4", blower to heater	BN4-BJ8	1
CHT160a	Schlauch-Schnelle 3 1/4"	clip 3 1/4", wire type	BN4-BJ8	2

Lüftungsschlitze / Hot Air Outlets

EM1aTR	Halteclip	nut, spire	BN4-BJ8	6
K09MGA-32	Luftschlauch Armaturen Brett	hose defroster	BN4-BJ8	2
K33MGB-13	Winkelschlauch Luftzufuhr Heizung	elbow assembly, hot air	BN4-BJ8	4
i505AH	Blende Lüftungsschlitze zur Scheibe	mask, hot air outlet, defroster	BN4-BJ8	2
i505AH/C	Blende Lüftungsschlitze zur Scheibe, chrom	mask, hot air outlet, defroster, chrome	BN4-BJ8	2

Frischlufsystem / Fresh Air System

K12MGA-32	Defrosterschlauch „lang“ 4"	hose 4"	BN4-BJ8	1
K15aAH	Stutzen Lufteinlass vorne	flange, bulkhead, fresh air	BN4-BJ8	1
K15bAH	Lufteinlass + Klappe	intake assembly	BN4-BJ8	1
K35AH	Drahtgeflecht Lufteinlass	gauze	BN4-BJ8	1

Heizungsbedienung / Heater Controls

W15TR4	Heizungszug	cable, fresh air control	BN4-BJ8	1
W16TR4	Luftregulierungszug	cable, heater air inlet control	BN4-BJ8	1
W16SPT	Lüfterzug	cable, water valve control	BN4-BJ8	1
K21AH	Kaltluft Regulierknopf	knob, fresh air control cable	BN4-BJ8	1
B24MGA-22	Klammer	clip, fresh air control cable	BN4-BJ8	1
K36AH	Knopf Heissluft	knob, heater air control cable	BN4-BJ8	1
K39AH	Heizungsschalter	control lever assembly	BN4-BJ8	1
K40AH	Knopf Heisschieber	knob, levre control	BN4-BJ8	1
K44MGA-32	Bolzen und Buchse	mounting kit, control panel	BN4-BJ8	2
K46AH	Schieberblende Heizung	panel, heater control	BN4-BJ8	1
V132AH	Gelenkstift	trunnion and screw, cables	BN4-BJ8	4

Kühler / Radiator BN1-BN2

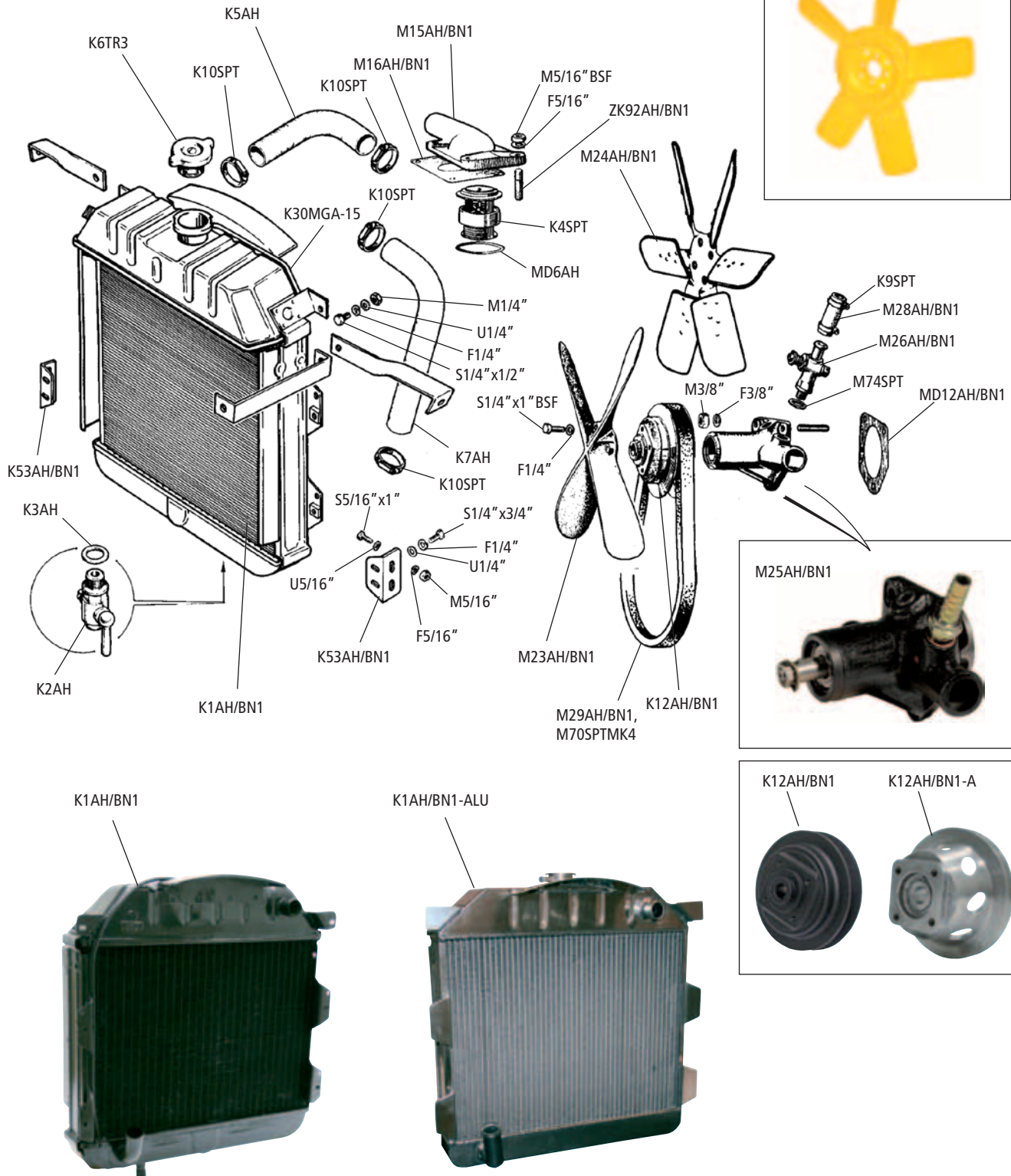

Bitte beachten Sie, dass bei den Modellen 100/4 (BN1 bis Fgst.Nr. 221403) fast ausschließlich Schrauben und Muttern mit B.S.F. Gewinde verwendet wurden. Die angegebenen Schrauben und Muttern in der Illustration beziehen sich auf BN2-BJ8 Modelle mit UNF Gewinde! – B.S.F. Schrauben und Muttern finden Sie in der separaten Auflistung auf S. 226-227.

Please note that on 100/4 models (BN1 up to chassis number 221403) the threads used have been almost exclusively B.S.F. The nuts and bolts referred to in the illustration are for the later BN2-BJ8 models with UNF thread!
- You will find details of the B.S.F. nuts and bolts in a separate list on page 226-227.

Kühler / Radiator BN1-BN2 (100-4)

No.	Bezeichnung	Description	Type	Anzahl/Qty.
K1AH/BN1	Kühler	radiator assembly	BN1-BN2	1
K1AH/BN1-ALU	Kühler Aluminium	radiator assembly, alloy	BN1-BN2	1
K2AH	Wasserablasshahn	drain tap	BN1-BN2	1
K3AH	Fiberscheibe	sealing washer	BN1-BN2	A/R
K4SPT	Thermostat 74 Grad	thermostat 74 °C	BN1-BN2	1
K4aSPT	Thermostat 82 Grad	thermostat 82 °C	BN1-BN2	1
K5AH	Kühler-Schlauch oben	radiator hose, top	BN1-BN2	1
K6TR3	Kühlerdeckel	radiator cap	BN1-BN2	1
MD6AH	Dichtung Thermostat-Gehäuse	gasket, thermostat	BN1-BN2	1
K7AH	Kühler-Schlauch unten	radiator hose, buttom	BN1-BN2	1
K9SPT	Schlauchschele Heizung	clip	BN1-BN2	2
K10SPT	Schlauchschele 30-45mm	clip, hose	BN1-BN2	4
K12AH/BN1	Keilriemenscheibe Wasserpumpe	pulley	BN1-BN2	1
K12AH/BN1-A	Keilriemenscheibe Wasserpumpe Alu für schmalen Keilriemen	pulley, alloy (small fan belt)	BN1-BN2	1
MD12AH/BN1	Dichtung Wasserpumpe	gasket, water pump to block	BN1-BN2	1
M15AH/BN1	Deckel Thermostat-Gehäuse	water outlet elbow	BN1-BN2	1
M16AH/BN1	Dichtung Thermostat-Gehäuse	gasket	BN1-BN2	1
M23AH/BN1	Lüfterflügel 4-Flügel Aluminium-Guß	fan, cast alloy (4 blade)	BN1-BN2	1
M24AH/BN1	Lüfterflügel 6-Flügel	fan, 6 blade	BN1-BN2	1
M25AH/BN1	Wasserpumpe	water pump	BN1-BN2	1
M26AH/BN1	Absperrventil Heizung an Wasserpumpe	heater tap, at water pump	BN1-BN2	1
M28AH/BN1	Schlauch Absperrventil zu Rohr	hose, tap to outlet pipe	BN1-BN2	1
M29AH/BN1	Keilriemen 17x1100	fan belt	BN1-BN2	1
K30MGA-15	Überlaufschlauch Kühler	overflow pipe	BN1-BN2	1
K53AH/BN1	Halteblech Kühler unten	radiator support bracket	BN1-BN2	2
M70SPTMK4	Keilriemen für Umbau auf schmalen Keilriemen	fan belt (for conversion kit to small v-belt)	BN1-BN2	1
M74SPT	Kupferdichtring	washer, copper	BN1-BN2	1
ZK92AH/BN1	Stehbolzen Deckel Thermostatgehäuse	stud, thermostat housing	BN1-BN2	4
M108aAH	Hochleistungs-Lüfterflügel Kunststoff	high performance radiator fan, plastic	BN1-BN2	1

Ölkühler / Oil cooler BN1-BJ8

No.	Bezeichnung	Description	Type	Anzahl/Qty.
K15cSPT	Schlauchanschlussplatte	hose connection plate	BN1-BJ8	1
K15eTR	Anschlussverschraubung	bolt connection	BN1-BJ8	1
K17SPT	Ölkühler 13 Reihen	oil coller 13 rows	BN1-BJ8	1
K28aTR6	Stahlummantelter Schlauch	steel reinforced hose	BN1-BJ8	2
K30TR	Ölkühler 16 Reihen	oil cooler 16 rows	BN1-BJ8	1
M97VOB18	Ölfilter	oil filter	BN1-BJ8	1
M140AH	Einweg Ölfilter-Adapter	adaptor, oil filter	BN1-BJ8	1
K320AH	Ölkühler Kit mit Stahlschläuchen inkl. 13-reihigem Ölkühler und Ölfilter	Oil cooler set with steel reinforced hoses incl. oil filter	BN1-BJ8	1

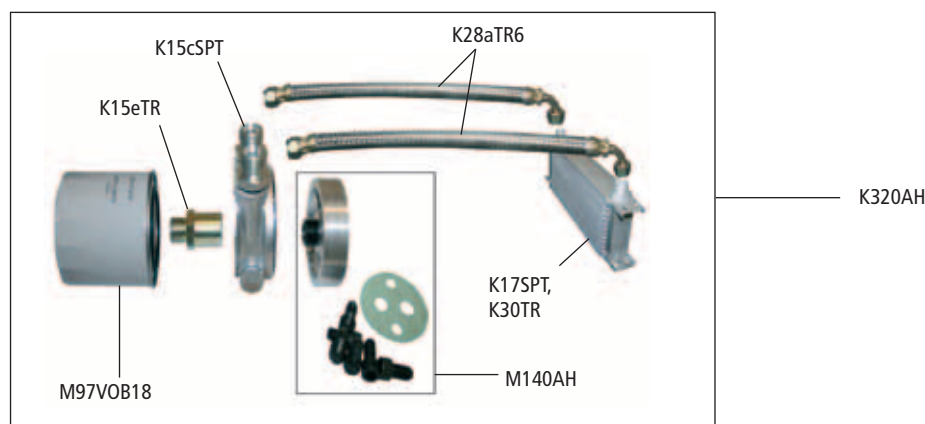

Kühler / Radiator BN4-BJ8

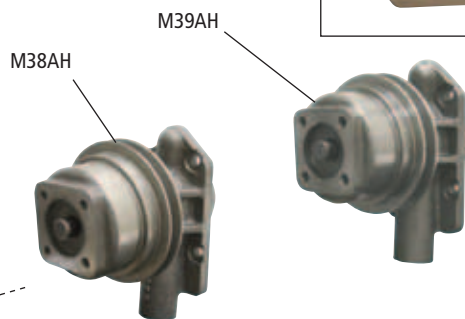

M22GT6, M105AH

F5/16"

S5/16" x3/4"

K1AH

K6TR3

K10SPT

K4AH

K30MGA-15

K10SPT

U5/16"

S5/16" x3/4"

F5/16"

K10SPT

K9SPT

M25AH

M5/16"

F5/16"

ZK06MGA-08

K4SPT

MD6SPT

MD6AH

K6AH

K6aAH

K10SPT

S5/16" x2"

M108AH

KA119AH..

K53AH/BN1

K3AH

K2AH

K53AH/BN1

M5/16"

F5/16"

U5/16"

F5/16"

S5/16" x3/4"

U5/16"

S1/4" x3/4"

U1/4"

F1/4"

M1/4"

F1/4"

K1AH



Kühler / Radiator BN4-BJ8 (100-6, 3000)

No.	Bezeichnung	Description	Type	Anzahl/Qty.
K1AH	Hochleistungs Kühler	high performance radiator assembly	BN4-BJ8	1
K1AH-ALU	Kühler Aluminium	radiator assembly, alloy	BN4-BJ8	1
K2AH	Wasserablasshahn	drain tap	BN4-BJ8	1
K3AH	Fiberscheibe	sealing washer	BN4-BJ8	A/R
K4AH	Kühlerschlauch oben	radiator hose, top	BN4-BJ8	1
K4SPT	Thermostat 74 Grad	thermostat 74 °C	BN4-BJ8	1
K4aSPT	Thermostat 82 Grad	thermostat 82 °C	BN4-BJ8	1
MD6AH	Thermostatdichtung	gasket, thermostat	BN4-BJ8	1
MD6SPT	Thermostatdichtung	gasket, thermostat	BN4-BJ8	1
ZK06MGA-08	Stehbolzen UNF	stud UNF	BN4-BJ8	2
K6AH	Kühlerschlauch unten	radiator hose, bottom	BN4-BJ8	1
K6TR3	Kühlerdeckel	radiator cap	BN4-BJ8	1
K9SPT	Schlauchschele 12-22mm	clip	BN4-BJ8	1
K10SPT	Schlauchschele 30-45mm	clip, hose	BN4-BJ8	4
M22GT6	Keilriemen 10mm Breite	fan belt, 10 mm	BN4-BJ8	1
M25AH	Thermostat-Gehäuse	thermostat housing	BN4-BJ8	1
K30MGA-15	Überlaufschlauch Kühler 77cm lang	overflow pipe	BN4-BJ8	1
M37AH	Wasserpumpendichtung	gasket, water pump	BN4-BJ8	1
M38AH	Wasserpumpe 3/8" breite Riemenscheibe	water pump, 3/8" pulley	BN4, BN6, BN7, BJ7, BT7, BJ8 < 29K-H10271	1
M39AH	Wasserpumpe 1/2" breite Riemenscheibe	water pump, 1/2" pulley	BJ8 > 29K-H10272	1
K53AH/BN1	Halteblech Kühler unten	radiator support bracket	BN4 > 40501-BJ8	2
M105AH	Keilriemen 12mm breit	fan belt (for conversion kit to small v-belt)	BJ8	1
M105AH/BN4	Keilriemen	fan belt	BN4-BN6	1
M108aAH	Hochleistungs-Lüfterflügel Kunststoff 5-Blätter	high performance radiator fan, plastic (5 blade)	BN4-BJ8	1
M108AH	Lüfterflügel Metall 6-Flügel	radiator fan, metall (6 blade)	BN4-BJ8	1
KA119AH/BJ7	Luftführung zu Kühler	air deflector assembly	BN7, BT7 > 13751, BJ7, BJ8 mit senkrechtem Grill / vertical grille models	1
KA119AH/BN4	Luftführung zu Kühler	air deflector assembly	BN4 > 47184RHD/47191LHD, BN6, BN7, BT7 < 13750	1

Elektrolüfter / Electric fan BN1-BJ8

No.	Bezeichnung	Description	Type	Anzahl/Qty.
K20SPT	Elektrolüfter	electric fan	BN1-BJ8	1
K20aSPT	Ventilatorhalter universal (4x erforderlich)	fan fitting kit, universal (necessary 4x)	BN1-BJ8	4
K21SPT	Thermostat	thermostat	BN1-BJ8	1
K22SPT	Wasserrohr mit Anschlussgewinde	water hose with thread	BN1-BJ8	1
K200SPT	Elektrolüfter-Kit - bestehend aus: Elektrolüfter, Universalhalter (4x), Wasserrohr mit Anschluss-gewinde, Thermostat	Electric fan kit - contains: electric fan, fan fitting kit (4x), water hose with thread, thermostat	BN1-BJ8	1

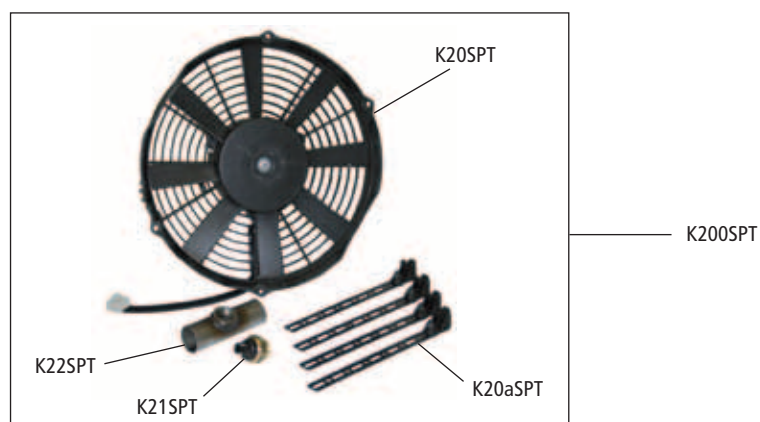
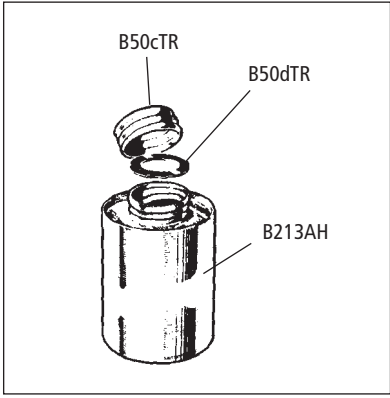
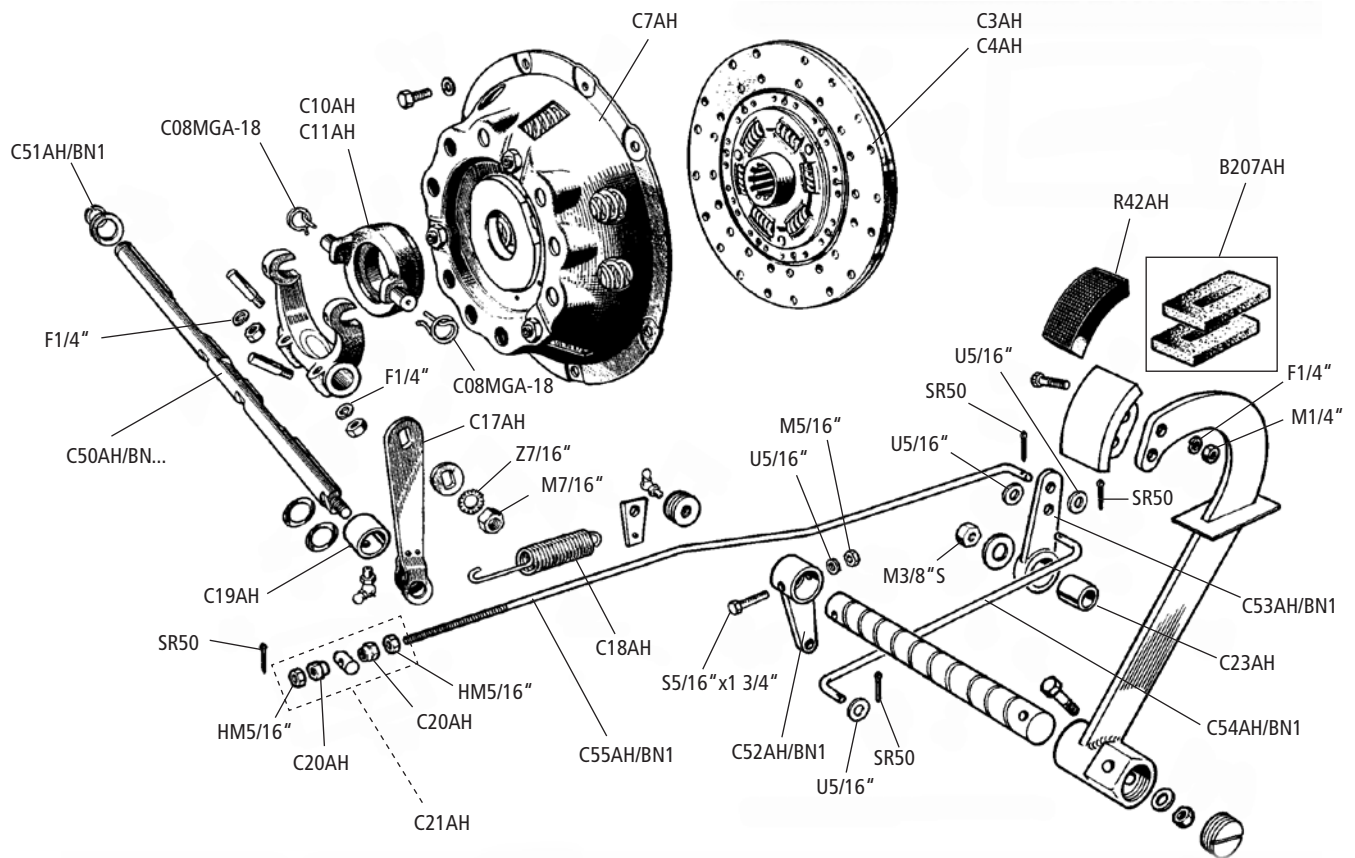

Illustration: BN1-BN2 (RHD)



C5AH, C6AH
C7AH



C3AH
C4AH



C10AH
C11AH



BR05 **

No.	Bezeichnung	Description	Type	Anzahl/Qty.
C3AH	Kupplungsscheibe	clutch plate	BN2	1
C4AH	Kupplungsscheibe	clutch plate	BN1	1
C7AH	Kupplungsautomat	clutch cover	BN1	1
C08MGA-18	Klammer Kupplungslager	clip clutch release bearing	BN1, BN2	2
B9aSPT	Abdeckkappe Entlüftungsnippel	cap air bleed screw	BN1, BN2	1
C10AH	Kupplungslager	clutch release bearing	BN2	1
C11AH	Kupplungslager	clutch release bearing	BN1	1
C17AH	Ausrückhebel Kupplung	clutch release lever	BN1, BN2	1
C18AH	Feder Kupplungsgestänge	return spring clutch lever	BN1, BN2	1
C19AH	Buchse Kupplungswelle (Getriebeglocke)	bush clutch shaft (gearbox case)	BN1, BN2	1
C20AH	Mutter Kupplungsspiel	nut clutch adjusting	BN1, BN2	1
C21AH	Verbinder Kupplungsgabel (Satz)	trunnion clutch lever (set)	BN1, BN2	1
HM5/16"	Mutter	nut	BN1, BN2	A/R
C23AH	Buchse Kupplungsausrückhebel	bush clutch release lever	BN1, BN2	1
B27SPT	Entlüftungsnippel	air bleed screw	BN1, BN2	1
C30AH	Sicherungsstift	clevis pin	BN1, BN2	1
C36MGB-20	Sicherungsstift	clevis pin	BN1, BN2	1
R42AH	Pedalgummi	pedal rubber	BN1, BN2	1
B50cTR	Deckel Flüssigkeitsbehälter	cover fluid reservoir	BN1, BN2	1
B50dTR	Dichtung Flüssigkeitsbehälter	seal fluid reservoir	BN1-BJ8	1
C50AH/BN1	Ausrückwelle	shaft, clutch operating	BN1, LHD	1
C50AH/BN1-RHD	Ausrückwelle	shaft, clutch operating	BN1, RHD	1
C50AH/BN2	Ausrückwelle	shaft, clutch operating	BN2, LHD	1
C50AH/BN2-RHD	Ausrückwelle	shaft, clutch operating	BN2, RHD	1
C51AH/BN1	Sicherungsring Ausrückwelle	circlip	BN1, BN2	1
C52AH/BN1	Umlenkhebel Kuppl.-gestänge an Pedalwelle	lever, clutch connecting rod	BN1, BN2	1
C53AH/BN1	Umlenkhebel Kuppl.-gestänge	relay lever, clutch	BN1, BN2	1
C54AH/BN1	Kuppl.-gestänge Pedal zu Umlenkhebel	connecting rod, clutch	BN1, BN2	1
C55AH/BN1	Kuppl.-gestänge Umlenkhebel zu Ausrückwelle	connecting rod, clutch	BN1, BN2	1
B207AH	Staubabdeckung (Paar) Pedaldurchführung/ Spritzwand	dust excluders, pedals (pair)	BN1, BN2	1
B213AH	Behälter Kupplungszyylinder für 1x Anschluß	tank, single supply	BN1, BN2	1
BR05	Kupplungsflüssigkeit 1/2 l	clutch fluid 1/2 l		
BR-Si05	Silikon Brems/Kupplungsflüssigkeit 1/2 l *	silicone brake/clutch fluid 1/2 l *		
BR-Si1	Silikon Brems/Kupplungsflüssigkeit 1 l *	silicone brake/clutch fluid 1 l *		

*** Anmerkungen zu BR-Si05, BR-Si1:**

Silikon Brems/Kupplungsflüssigkeit zieht keine Feuchtigkeit an, wodurch Rostansatz in den Leitungen vermieden und die Flüssigkeit auch nicht mehr jährlich gewechselt werden muß.

Sie weist zudem einen höheren Siedepunkt auf, verträgt sich mit allen Gummimanschetten und greift Lacke/Farben nicht an.



ACHTUNG! Silikon Brems- und Kupplungsflüssigkeit darf nicht mit einer anderen Brems/Kupplungsflüssigkeit vermischt werden!

*** Note to BR-Si05, BR-Si1:**

Silicone brake/clutch fluid does not absorb moisture from air like ordinary brake fluid. As a result, the brake/clutch pipes, the cylinders and hoses will last much longer and you do not have to change the fluid at least once a year. Also silicone brake/clutch fluid has a slightly higher boiling point.



WARNING! It is not possible to mix with other brake/clutch fluid!

** Abb. dient der Veranschaulichung, Produkt-/verpackung kann abweichen. / Image similarly, product and packing may vary.

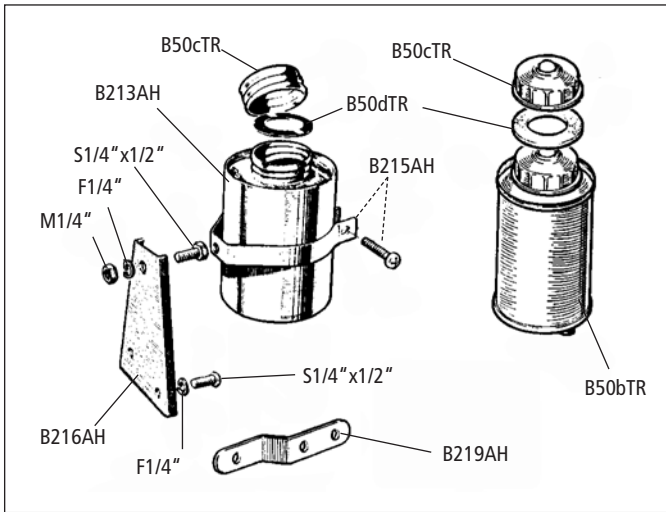
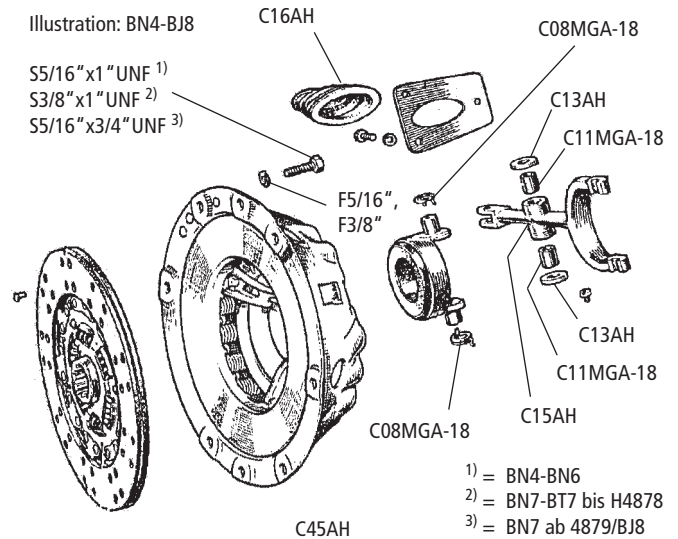
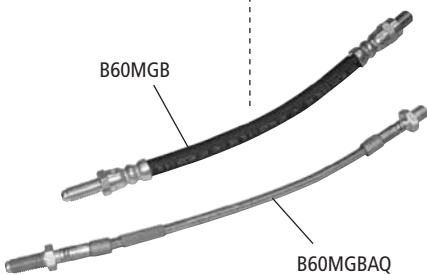
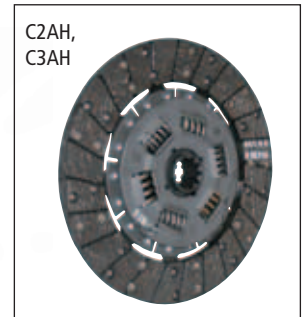
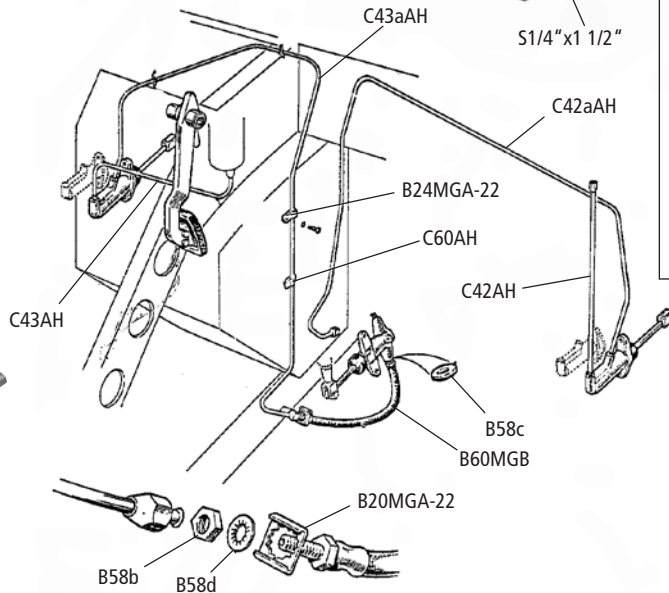
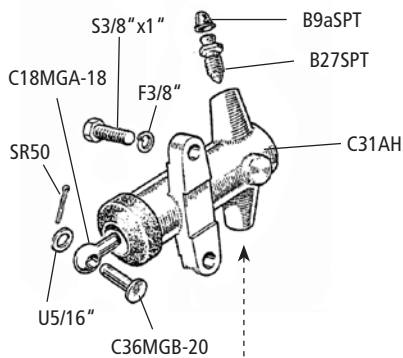
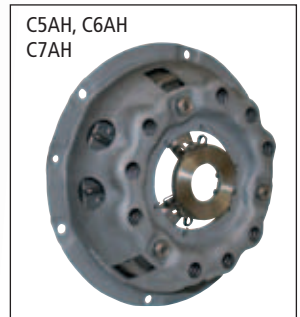
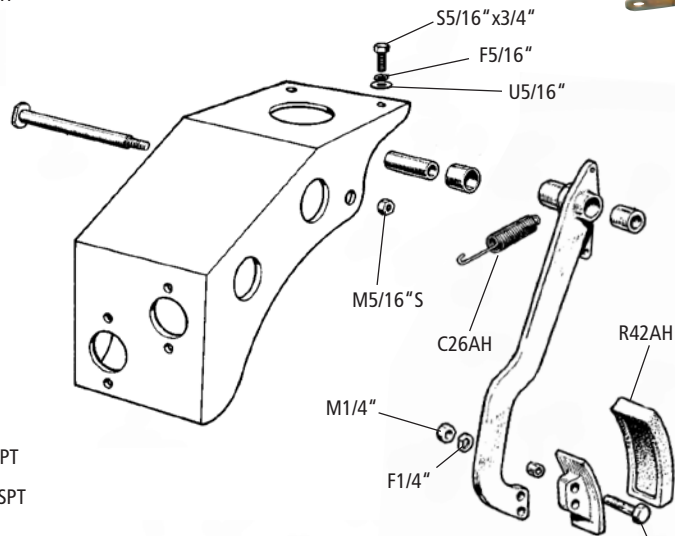
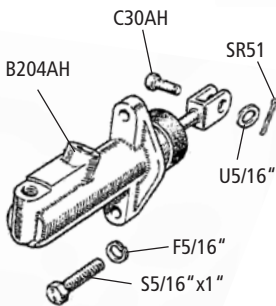
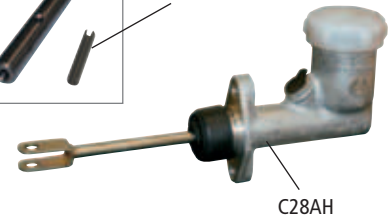
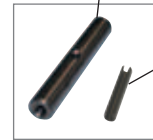
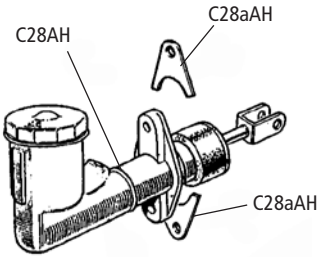

Illustration: BN4-BJ8

- S5/16" x 1" UNF ¹⁾
- S3/8" x 1" UNF ²⁾
- S5/16" x 3/4" UNF ³⁾



- 1) = BN4-BN6
- 2) = BN7-BT7 bis H4878
- 3) = BN7 ab 4879/BJ8



No.	Bezeichnung	Description	Type	Anzahl/Qty.
C2AH	Kupplungsscheibe (10"/25 cm)	clutch plate (10"/25 cm)	BN7-BT7/BJ7<Motor 29f4878	1
C3AH	Kupplungsscheibe (9"/23 cm)	clutch plate (9"/23 cm)	BN2-BN6, BJ7-BJ8>Motor 29f4879	1
C5AH	Kupplungsautomat (9"/23 cm)	clutch cover (9"/23 cm)	BJ7-BJ8>Motor 29f4879	1
C6AH	Kupplungsautomat (10"/25 cm)	clutch cover (10"/25 cm)	BN7-BT7-BJ7<Motor 29f4878	1
C7AH	Kupplungsautomat	clutch cover	BN4-BN6	1
C6AH	Reparatur-Satz Kupplungsgeberzylinder	clutch master repair kit	BN4-BJ8	1
C6SPT	Reparatur-Satz für B204AH	repair kit to no. B204AH	BN4>48863-BJ8	1
C08MGA-18	Klammer Kupplungslager	clip clutch release bearing	BN4-BJ8	2
C8AH	Kupplungslager	clutch release bearing	BJ7-BJ8>Motor 29f4879	1
C9AH	Kupplungslager	clutch release bearing	BN7-BT7-BJ7<Motor 29f4878	1
C10AH	Kupplungslager	clutch release bearing	BN4-BN6	1
B9aSPT	Abdeckkappe Entlüftungsrippel	cap air bleed screw	BN4-BJ8	1
C11MGA-18	Buchse Kupplungsausrückhebel	bush clutch lever	BN4-BJ8	2
C13AH	Anlaufscheibe Kupplungsausrückhebel	thrust washer clutch lever	BN4-BJ8	2
C15AH	Kupplungsgabel	clutch release lever	BN4-BJ8	1
C16AH	Gummi Kupplungshebel	gaiter clutch lever	BN4-BJ8	1
C18MGA-18	Druckstange Kupplungsnehmerzylinder	push rod clutch slave cylinder	BN4-BJ8	1
HM5/16"	Mutter	nut	BN4-BJ8	A/R
C25AH	Lagerbuchse Kupplungspedal	bush bearing clutch pedal	BN4-BJ8	2
C26AH	Rückholfeder Kupplungspedal	return spring clutch pedal	BN4-BJ8	1
B27SPT	Entlüftungsrippel	air bleed screw	BN4-BJ8	1
B20MGA-22	Sicherungsblech	lockplate	BN4-BJ8	1
B24MGA-22	Klammer Kupplungsleitung	clip, pipe	BN4-BJ8	1
B204AH	Kupplungsgeberzylinder (separater Flüssigkeitsbehälter)	clutch master cylinder (separate clutch fluid reservoir)	BN4>48863-BJ8	1
C28AH	Kupplungsgeberzylinder (integrierter Flüssigkeitsbehälter)	clutch master cylinder (built in clutch fluid reservoir)	BN4<48862	1
C28aAH	Halter Kupplungszyylinder	shim	BN4-BJ8	2
C30AH	Sicherungsstift	clevis pin	BN4-BJ8	1
C31AH	Kupplungsnehmerzylinder	clutch slave cylinder	BN4-BJ8	1
C32AH	Reparatur-Satz Kupplungsnehmerzylinder	clutch slave repair kit	BN4-BJ8	1
C36MGB-20	Sicherungsstift	clevis pin	BN4-BJ8	1
R42AH	Pedalgummi	pedal rubber	BN1-BJ8	1
C42AH	Leitung Kupplungsbehälter LHD	pipe clutch master cyl./reservoir lhd	BN4>48863-BJ8	1
C42aAH	Leitung Kupplungsbehälter / K.-Schlauch LHD	pipe clutch master cyl./hose lhd	BN4-BJ8	1
C43AH	Leitung Kupplungsbehälter RHD	pipe clutch master cyl./reservoir rhd	BN4>48863-BJ8	1
C43aAH	Leitung Kupplungsbehälter / K.-Schlauch RHD	pipe clutch master cyl./hose rhd	BN4-BJ8	1
C45AH	Lagerwelle und Spannstift	shaft clutch fork	BN4-BJ8	1
C46AH	Spannstift	split pin	BN2-BJ8	1
B50bTR	Kupplungsflüssigkeitsbehälter, 2 Anschlüsse	master cylinder reservoir, dual supply	BN4>48863-BJ8	1
B50cTR	Deckel Flüssigkeitsbehälter	cover fluid reservoir	BN4-BJ8	1
B50dTR	Dichtung Flüssigkeitsbehälter	seal fluid reservoir	BN1-BJ8	1
B51aTR	Reparatur-Satz für C28AH	repair kit to no. C28AH	BN4>48862	1
SR50	Splint	split pin	BN4-BJ8	1
SR51	Splint	split pin	BN4-BJ8	1
B58b	Kontermutter Kupplungs-/Bremsschlauch	nut	BN4-BJ8	1
B58c	Kupferdichtung für Kupplungsschlauch	copper washer	BN4-BJ8	1
B58d	Zahnscheibe für Kupplungsschlauch	washer, shakeproof	BN4-BJ8	1
B60MGB	Kupplungsschlauch „Gummi“	clutch hose „rubber“	BN4-BJ8	1
B60MGBAQ	Kupplungsschlauch stahlummantelt	clutch hose, steel coated	BN4-BJ8	1
C60AH	Halteklammer Kupplungsleitung	clip	BN4-BJ8	1
B215AH	Halter für Kupplungszyylinder	bracket, clutch cylinder	BN6-BJ8	1
B216AH	Halter Flüssigkeitsbehälter RHD	bracket, supply tank RHD	BN6-BJ8	1
B219AH	Halter Flüssigkeitsbehälter LHD	bracket, supply tank LHD	BN6-BJ8	1
BR05	Kupplungsflüssigkeit 1/2 l	clutch fluid 1/2 l		
BR-Si05	Silikon Brems/Kupplungsflüssigkeit 1/2 l *	silicone brake/clutch fluid 1/2 l *		
BR-Si1	Silikon Brems/Kupplungsflüssigkeit 1 l *	silicone brake/clutch fluid 1 l *		

* Anmerkungen zu BR-Si05, BR-Si1: siehe Seite 71
 * note to BR-Si05, BR-Si1: see page 71

Getriebe 3-Gang / Gearbox 3 speed BN1

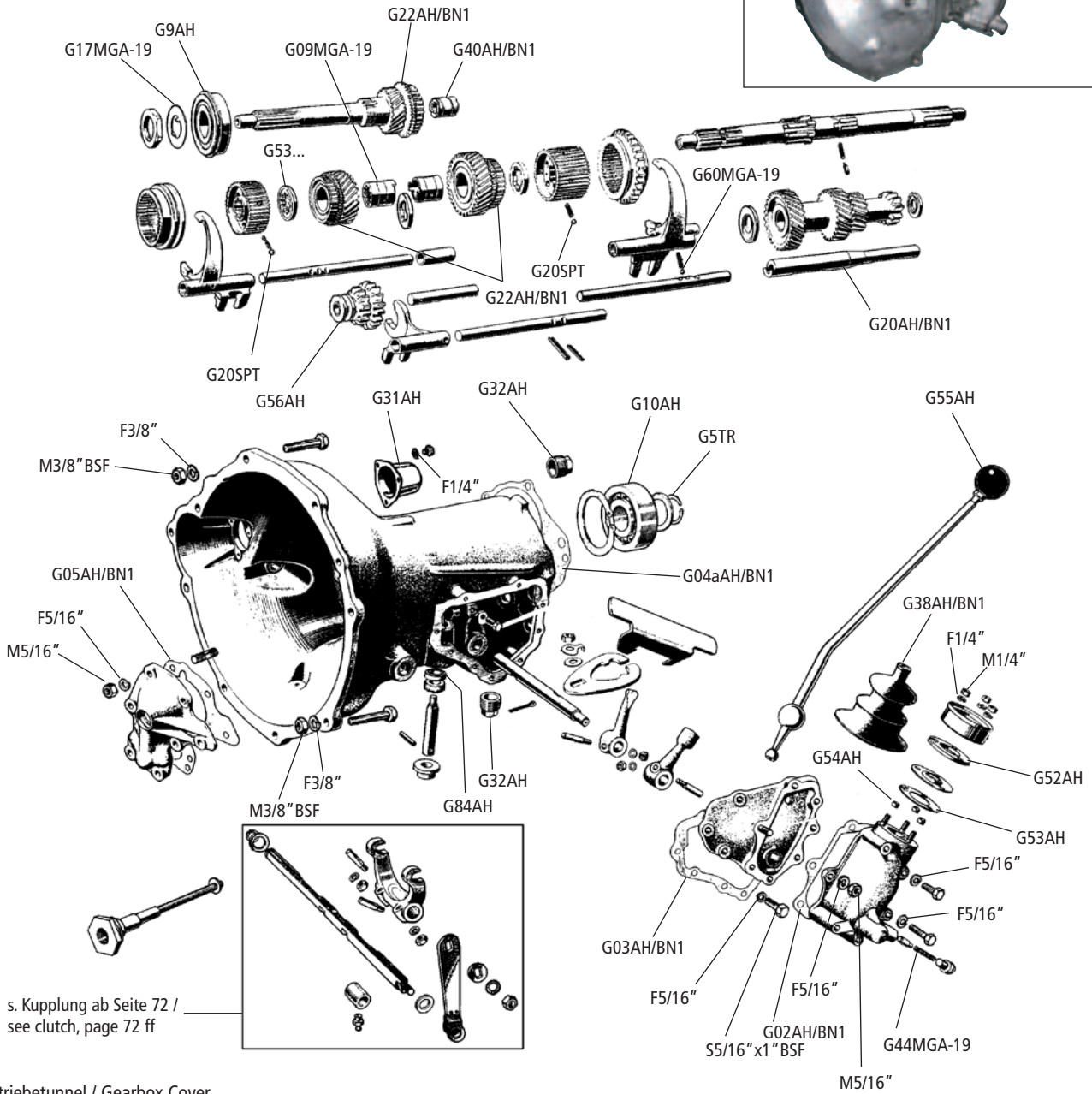
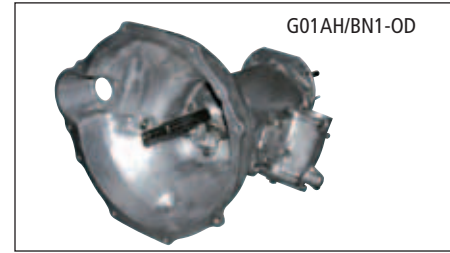

s. Kupplung ab Seite 72 / see clutch, page 72 ff

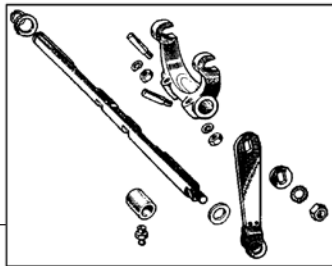

Getriebetunnel / Gearbox Cover

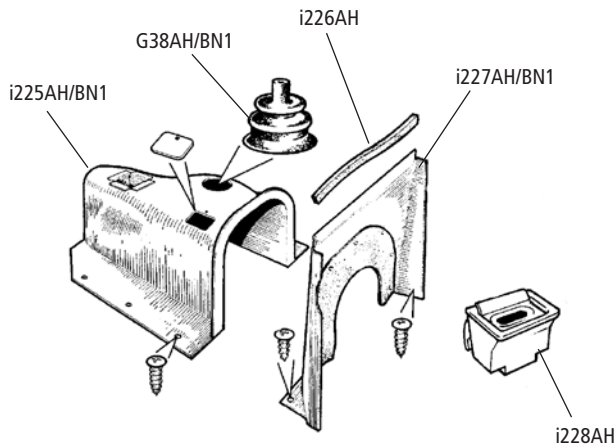

Getriebebefestigung / Gearbox Mountings

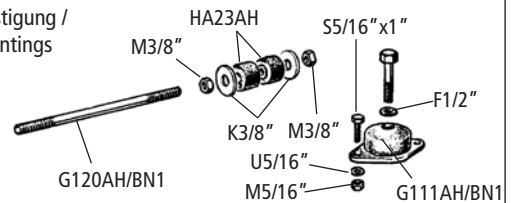

Getriebe 3-Gang / Gearbox 3 speed BN1

No.	Bezeichnung	Description	Type	Anzahl/Qty.
G01AH/BN1-OD	AT-Getriebe Seitenschaltung 3-Gang für Overdrive	gearbox ass. 3 speed, sideshift for overdrive use, exchange	BN1	1
G02AH/BN1	Dichtung Seitendeckel zu Schaltung	gasket, body side to cover	BN1	1
G03AH/BN1	Dichtung Seitendeckel-Gehäuse	gasket, side cover	BN1	1
G3AH/BN1	Getriebe Dichtsatz	gasket set	BN1	1
G04aAH/BN1	Dichtung Getriebehals	gasket, casing to o/d adaptor plate	BN1	1
G05AH/BN1	Gehäusedeckeldichtung	gasket, front cover	BN1	1
G5TR	Sicherungsring	circlip	BN1	1
G9AH	Kugellager Getriebe	bearing	BN1	1
G09MGA-19	Buchse 3. Gang	bush, 3rd speed mainshaft gear	BN1	1
G10AH	Kugellager Getriebe	bearing, main shaft	BN1	1
G12AH	Synchronkörper 2. Gang	synchronizer, 2nd speed	BN1	1
G12bAH	Synchronkörper 3. + 4. Gang	synchronizer 3rd & 4th	BN1	1
G17MGA-19	Sicherungsscheibe	lockwasher	BN1	1
G20AH/BN1	Vorgelegewelle	layshaft	BN1	1
G20SPT	Kugel Ø 1/4"	ball 1/4"	BN1	9
G22AH/BN1	Synchronring	synchro cone	BN1	3
G31AH	Abdeckkappe Anlasser-Ritzel	cover, starter pinion	BN1	1
G32AH	Abdeckstopfen	plug, oil drain/filler	BN1	2
G38AH/BN1	Schalthebelgummi	boot, gearshift	BN1	1
G40AH/BN1	Büchse Getriebeeingangswelle	bush, 1. motion shaft	BN1	1
G44MGA-19	Feder	spring	BN1	1
G52AH	Gummi Scheibe Schalthebel dick	pad, shift lever packing (thick)	BN1	1
G53AH	Gummi Scheibe Schalthebel dünn	washer, sealing, rubber (thin)	BN1	1
G53MGA-19	Anlaufscheibe „3.962-3.988"	thrust washer „3.962-3.988"	BN1	1
G53aMGA-19	Anlaufscheibe „4.013-4.039"	thrust washer „4.013-4.039"	BN1	1
G53bMGA-19	Anlaufscheibe „4.060-4.085"	thrust washer „4.060-4.085"	BN1	1
G54AH	Abdeckung Distanzstück	distance piece	BN1	3
G55AH	Schaltknopf	knob, gearshift	BN1	1
G56AH	Rückwärtsgangrad	gear, reverse	BN1	1
G60MGA-19	Kugel 9/32"	ball 9/32"	BN1	3
G84AH	Dichtring Getriebestift	oil seal	BN1	1
S5/16X1"BSF	Schraube 5/16"x1"BSF	screw 5/16"x1"BSF	BN1	3

Getriebetunnel / Gearbox Covers

G38AH/BN1	Schalthebelgummi	boot, shift lever	BN1	1
i225AH/BN1	Getriebetunnel aus GFK	gearbox cover GFK	BN1	1
i226AH	Dichtsatz Getriebetunnel	seal set, gearbox cover	BN1	1
i227AH/BN1	Anschlussblech Getriebetunnel	extension panel, gearbox cover	BN1	1
i228AH	Aschenbecher	ashtray assembly	BN1	1

Getriebebefestigung / Gearbox Mountings

HA23AH	Gummi-Buchse	bush, rubber, tie rod	BN1	4
G111AH/BN1	Gummilager Getriebehals	mounting, gearbox, unf	BN1	2
G120AH/BN1	Getriebestützstrebe	tie rod, engine	BN1	1

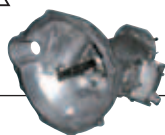
Hinweis /
Note

3 Jahre Garantie auf alle mechanischen Teile unserer AT-Getriebe und AT-Overdrives.

Beachten Sie bitte die Hinweise zu den Austauschgetrieben und - Overdrives auf Seite 23!

3 years guarantee on all mechanical gearbox and overdrive components.

Please refer to our notes "Exchange Parts" on page 23!

Getriebe 4-Gang seitengeschaltet / External Gearbox 4 speed sideshift
BN2, BN4, BN6, BN7, BT7, BJ7

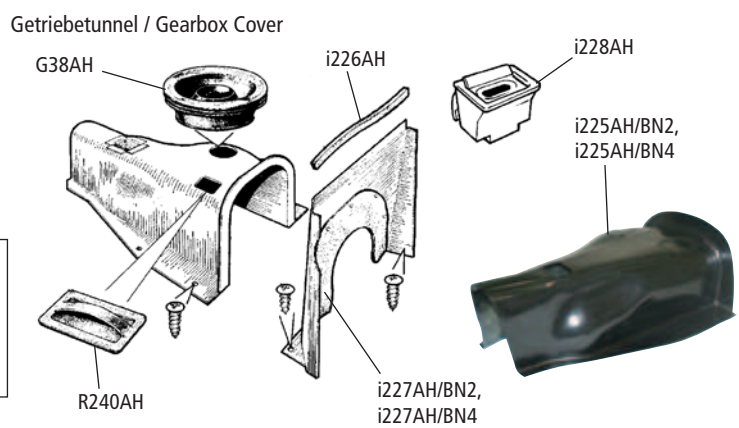
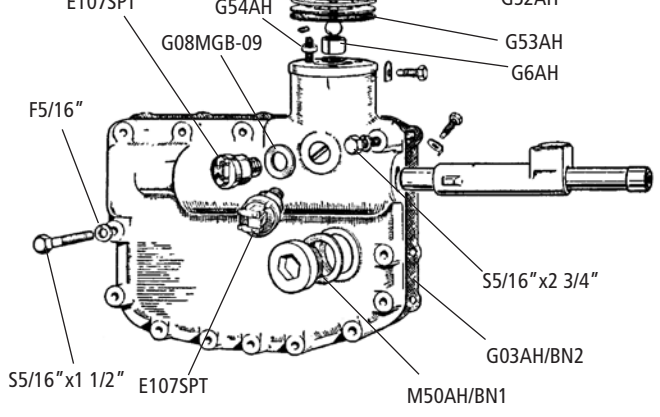
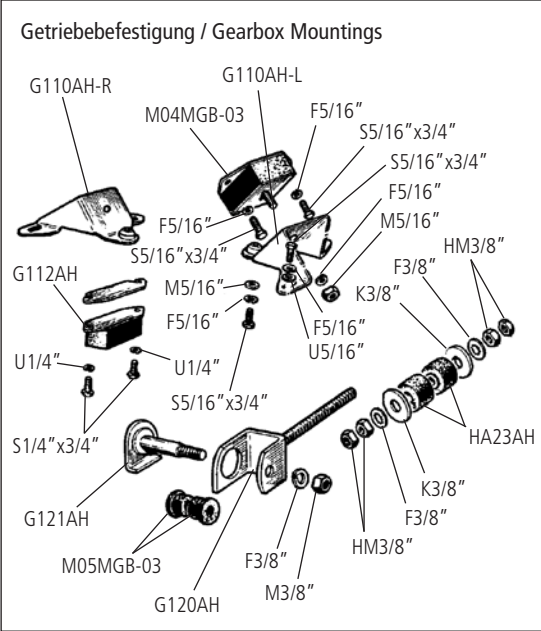
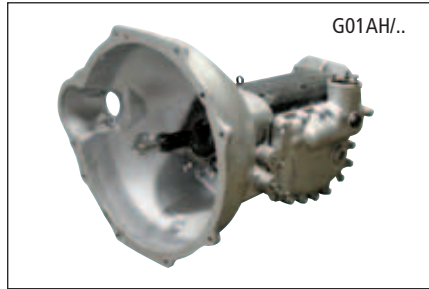
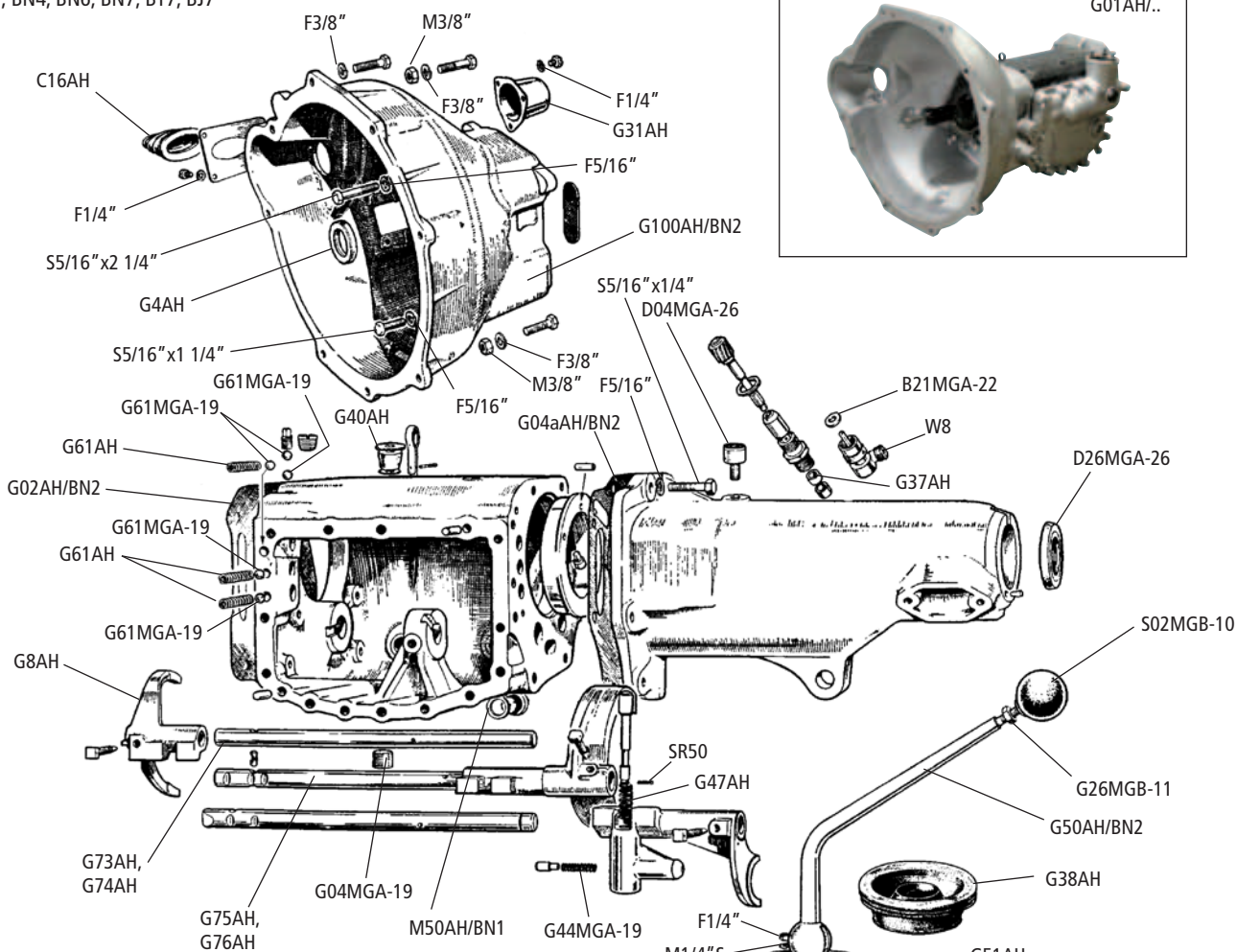

Hinweis / Note  Beachten Sie bitte die Hinweise zu den Austauschgetrieben und -Overdrives auf S. 75 und S. 23!
Please refer to our notes "Gearbox/Overdrives" and "Exchange Parts" on page 75 and 23!



Getriebe 4-Gang seitengeschaltet / Gearbox 4 speed sideshift BN2, BN4, BN6, BN7, BT7, BJ7

No.	Bezeichnung	Description	Type	Anzahl / Qty.
G01AH/BN4	AT-Getriebe Seitenschaltung Standard	gearbox ass. sideshift standard, exchange	BN2, BN4, BN6	1
G01AH/BN4-OD	AT-Getriebe Seitenschaltung für Overdrive	gearbox ass. sideshift, for overdrive , exchange	BN2, BN4, BN6	1
G01AH/BN7	AT-Getriebe Seitenschaltung Standard	gearbox ass. sideshift, standard, exchange	BN7, BT7, BJ7	1
G01AH/BN7-OD	AT-Getriebe Seitenschaltung für Overdrive	gearbox ass. sideshift, for overdrive , exchange	BN7, BT7, BJ7	1
S02MGB-10	Schaltnauf rund	knob, gear lever	BN2, BN4, BN6, BN7, BT7	1
G02AH/BN2	Dichtung Getriebeglocke	gasket, case to clutch housing	BN2, BN4, BN6, BN7, BT7	1
G03AH/BN2	Dichtung Schaltdeckel	gasket, cover to gearbox	BN2, BN4, BN6, BN7, BT7	1
G3AH	Getriebe Dichtsatz	gasket set	BN2, BN4, BN6, BN7, BT7	1
G4AH	Simmerring Getriebe vorne	seal, oil	BN2, BN7, BT7	1
G04aAH/BN2	Dichtung Getriebehals	gasket, casing overdrive to gearbox	BN4, BN6, BN7, BT7 ohne,w/o. OD	1
G04MGA-19	Ölablass/einfüll-Schraube	plug, oil drain	BN2, BN4, BN6, BN7, BT7	1
D04MGA-26	Entlüftungsventil	breather	BN4, BN6, BN7, BT7 ohne,w/o. OD	1
G6AH	Buchse Schalthebel +Klammer	bush, lever incl. circlip	BN4, BN6, BN7, BT7	1
G8AH	Schaltgabel 3. und 4. Gang	fork, striking, 3rd & 4th	BN2, BN4, BN6, BN7, BT7	1
W8	Winkelantrieb Tachowelle Overdrive	angle drive, speedometer	BN2, BN4, BN6, BN7, BT7	1
G08MGB-09	Fiberscheibe	washer, fiber	BN2, BN4, BN6, BN7, BT7	A/R
C16AH	Gummi-Balg Kupplungs-Hebel	boot, clutch fork	BN4, BN6, BN7, BT7	1
B21MGA-22	Kupferscheibe 7/16"	washer, adaptor	BN2, BN4, BN6, BN7, BT7	1
G26MGB-11	Mutter Schaltnauf	locknut, knob	BN2, BN4, BN6, BN7, BT7	1
D26MGA-26	Simmerring	seal, oil	BN4, BN6, BN7, BT7 ohne,w/o. OD	1
G31AH	Abdeckkappe Anlasserritzel	cover, starter end	BN2, BN4, BN6, BN7, BT7	1
G37AH	Dichtring Antriebsritzels	seal,oil, pinion	BN4, BN6, BN7, BT7 ohne,w/o. OD	1
G38AH	Schalthebelgummi	boot, gear shift	BN4, BN6, BN7, BT7 ohne,w/o. OD	1
G40AH	Dichtring Ölmeßstab	dipstick conversion	BN2, BN4, BN6, BN7, BT7	1
G44MGA-19	Feder	spring, detent plunger	BN2, BN4, BN6, BN7, BT7	1
G47AH	Feder Schaltkulisse Rückwärtsgang	spring, plunger	BN2, BN4, BN6, BN7, BT7	1
M50AH/BN1	Kupferdichtring	washer	BN2, BN4, BN6, BN7, BT7	A/R
G50AH/BN2	Schalthebel	shift lver	BN2, BN4, BN6, BN7, BT7	1
SR50	Splint 1.6mm x32mm	cotter pin	BN2, BN4, BN6, BN7, BT7	1
G51AH	Halter Schalthebel	cover, shift lever	BN2, BN4, BN6, BN7, BT7	1
G52AH	Gummi Scheibe Schalthebel dick	pad, shift lever packing, thick	BN2, BN4, BN6, BN7, BT7	1
G53AH	Gummi Scheibe Schalthebel dünn	pad, shift lever packing, thin	BN2, BN4, BN6, BN7, BT7	1
G54AH	Abdeckung Distanzstück	distance piece, cover	BN2, BN4, BN6, BN7, BT7	3
G61AH	Feder Schaltwelle	spring, ball	BN2, BN4, BN6, BN7, BT7	3
G61MGA-19	Kugel	ball, selector shaft	BN2, BN4, BN6, BN7, BT7	5
G73AH	Welle 3.Gang + 4.Gang	shaft, 3rd and 4th selector	BN4, BN6, BN7, BT7	1
G74AH	Welle 3.Gang + 4.Gang	shaft, 3rd and 4th selector	BN2	1
G75AH	Welle 1.Gang + 2.Gang	shaft, 1st and 2nd selector	BN2	1
G76AH	Welle 1.Gang + 2.Gang	shaft, 1st and 2nd selector	BN4, BN6, BN7, BT7	1
G100AH/BN2	Getriebeglocke	bell housing	BN2	1
E107SPT	Schalter auf Getriebedeckel	switch, overdrive on gearbox	BN2, BN4, BN6, BN7, BT7	1

Getriebetunnel / Gearbox Covers

G38AH	Schalthebelgummi für Seitenschaltung	boot, shift lever, sideshift	BN4, BN6, BN7<16038, BT7<15880	1
i225AH/BN4	Getriebetunnel Seitenschaltung GFK	gearbox cover GFK, sideshift	BN4, BN6, BN7<16038, BT7<15880	1
i225AH/BN2	Getriebetunnel Seitenschaltung GFK	gearbox cover GFK, sideshift	BN2	1
i226AH	Dichtsatz Getriebetunnel	seal set, gearbox cover	BN2, BN4, BN6, BN7, BT7, BJ7	1
i227AH/BN4	Anschlussblech Getriebetunnel	extension panel, gearbox cover	BN4, BN6, BN7<16038, BT7<15880	1
i227AH/BN2	Anschlussblech Getriebetunnel	extension panel, gearbox cover	BN2	1
i228AH	Aschenbecher	ashtray assembly	BN2, BN4, BN6, BN7, BT7, BJ7	1
R240AH	Stopfen Getriebetunnel	plug, gearbox cover	BN4, BN6, BN7<16038, BT7<15880	1

Getriebebefestigung / Gearbox Mountings

M04MGB-03	Gummilager Getriebehals hinten	mounting, gearbox	BN2, BN4, BN6, BN7, BT7, BJ7	2
M05MGB-03	Büchse Schubstrebe	bush, rubber, gearbox rear cover	BN2, BN4, BN6, BN7, BT7, BJ7	2
HA23AH	Gummibuchse	bush, rubber, tie rod	BN2, BN4, BN6, BN7, BT7, BJ7	2
G110AH-L	Halter Getriebe-Aufhängung links	bracket, mounting LH	BN2, BN4, BN6, BN7, BT7, BJ7	1
G110AH-R	Halter Getriebe-Aufhängung rechts	bracket, mounting RH	BN2, BN4, BN6, BN7, BT7, BJ7	1
G112AH	Gummiaufhängung Getriebe	rebound rubber	BN2, BN4, BN6, BN7, BT7, BJ7	1
G120AH	Getriebe Haltestrebe hinten	tie rod, engine	BN2, BN4, BN6, BN7, BT7, BJ7	1
G121AH	Lagerbolzen Anlenkhebel	pin, hinge	BN2, BN4, BN6, BN7, BT7, BJ7	1

Getriebe Mittelschaltung / Gearbox centershift
 BN7, BT7, BJ7, BJ8 ab/from Nov. 1961 E29E/2246 C BT7/15881

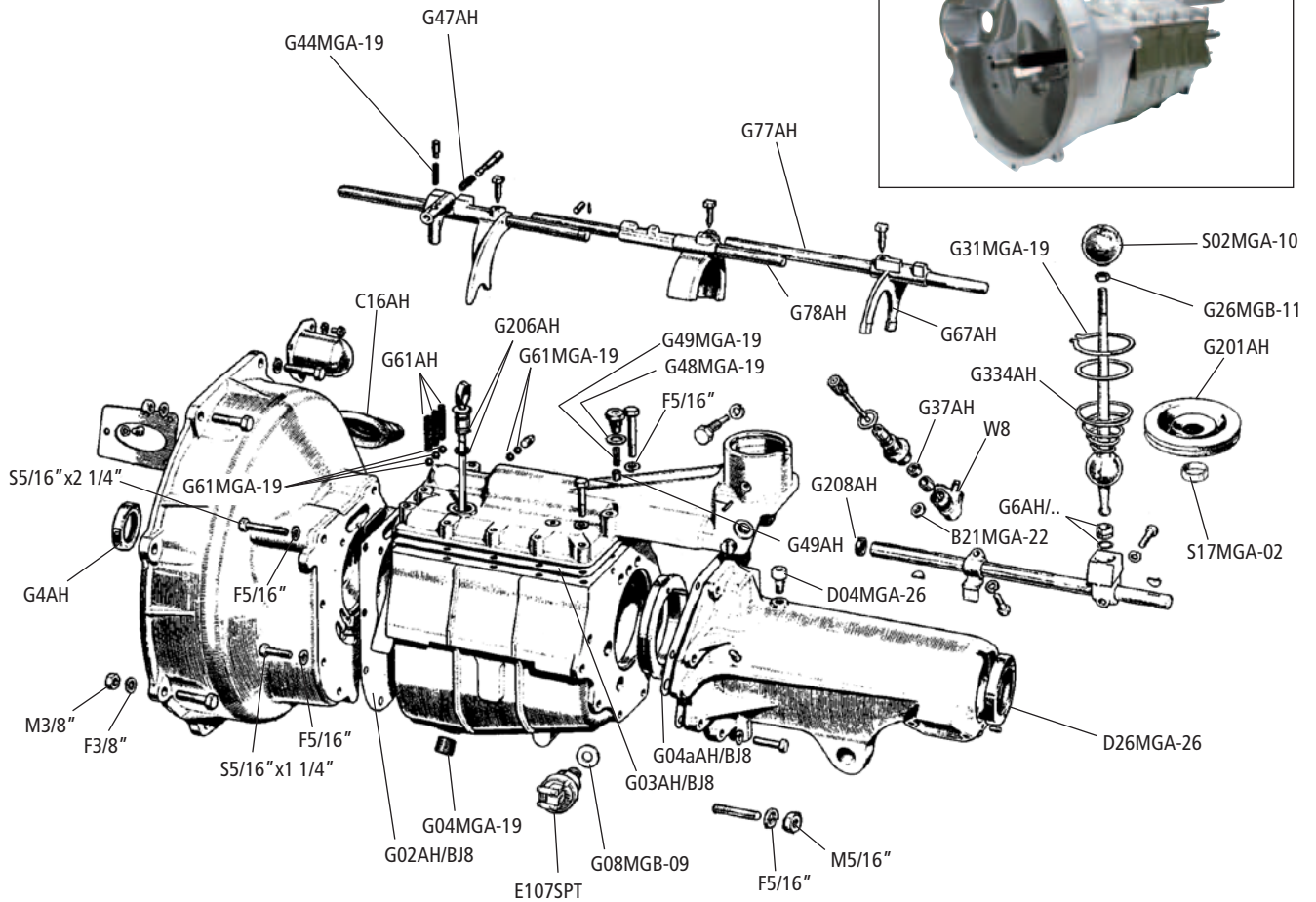

Getriebebefestigung / Gearbox Mountings

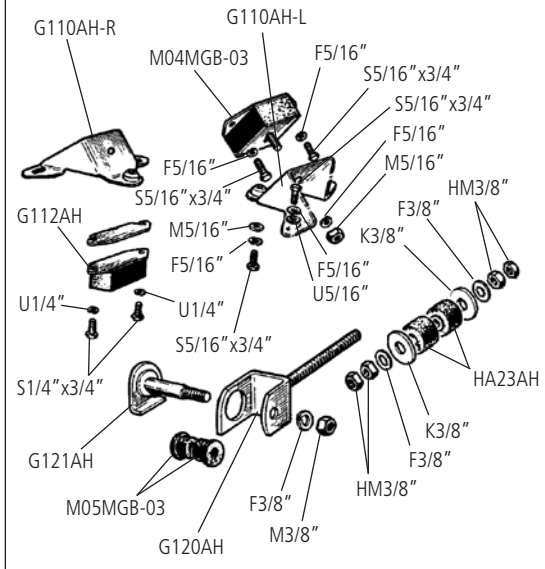

Getriebetunnel / Gearbox Cover

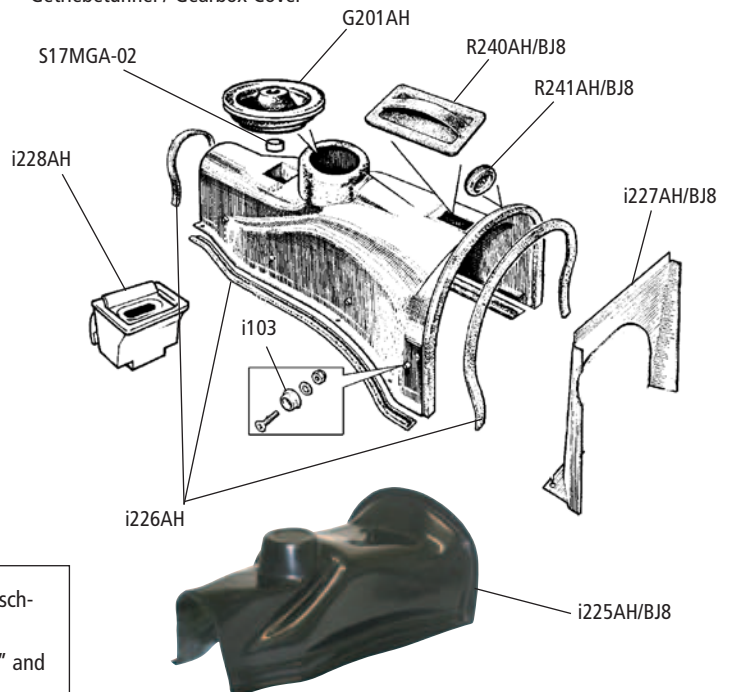

Hinweis / Note



Beachten Sie bitte die Hinweise zu den Austauschgetrieben und - Overdrives auf S. 75 und S. 23!
 Please refer to our notes "Gearbox/Overdrives" and "Exchange Parts" on page 75 and 23!



Getriebe Mittelschaltung / Gearbox centershift BN7, BT7, BJ7, BJ8 ab/from Nov. 1961 E29E/2246 C BT7/15881

No.	Bezeichnung	Description	Type	Anzahl/Qty.
G01AH/BJ7	AT-Getriebe Mittelschaltung Standard	gearbox ass. centershift, standard, exchange	BN7, BT7, BJ7	1
G01AH/BJ7-OD	AT-Getriebe Mittelschaltung für Overdrive	gearbox ass. centershift, overdrive, exchange	BN7, BT7, BJ7	1
G01AH/BJ8	AT-Getriebe Mittelschaltung Standard	gearbox ass.centershift, standard, exchange	BJ8	1
G01AH/BJ8-OD	AT-Getriebe Mittelschaltung für Overdrive	gearbox ass. centershift, overdrive, exchange	BJ8	1
S02MGB-10	Schaltknopf rund	knob, gear lever	BN7, BT7, BJ7, BJ8	1
G02AH/BJ8	Dichtung Getriebeglocke	gasket, case to clutch housing	BN7, BT7, BJ7, BJ8	1
G03AH/BJ8	Dichtung Schaltdeckel	gasket, gearbox to cover	BN7, BT7, BJ7, BJ8	1
G3AH	Getriebe Dichtsatz	gasket set	BN7, BT7, BJ7, BJ8	1
D04MGA-26	Entlüftungsventil	breather	BN7, BT7, BJ7, BJ8 ohne, w/o OD	1
G4AH	Simmerring Getriebe	seal, oil	BN7, BT7, BJ7, BJ8	1
G04aAH/BJ8	Dichtung Getriebehals	gasket	BN7, BT7, BJ7, BJ8	1
G04MGA-19	Ölablass/einfüll-Schraube	plug, oil drain	BN7, BT7, BJ7, BJ8	1
G6AH	Buchse Schalthebel + Klammer	bush assembly, lever incl. circlip	BN7, BT7, BJ7	1
G6AH/BJ8	Lagerbuchse Schalthebel Nylon	bush, lever, nylon	BJ8	1
G08MGB-09	Fiberscheibe	washer, fiber	BN7, BT7, BJ7, BJ8	1
W8	Winkelantrieb Tachowelle Overdrive	angle drive, speedometer	BN7, BT7, BJ7, BJ8	1
C16AH	Gummi-Balg Kupplungshebel	boot, clutch fork	BN7, BT7, BJ7, BJ8	1
S17MGA-02	Ring Schalthebel-Manschette	ring, gear lever boot	BN7, BT7, BJ7, BJ8	1
B21MGA-22	Kupferscheibe 7/16"	washer, adaptor	BN7, BT7, BJ7, BJ8	1
D26MGA-26	Simmerring	seal, oil	BN7, BT7, BJ7, BJ8 ohne, w/o OD	1
G26MGB-11	Mutter Schaltknopf	locknut, knob	BN7, BT7, BJ7, BJ8	1
G31MGA-19	Sicherungsclip Schalthebel	circlip	BN7, BT7, BJ7, BJ8	1
G37AH	Dichtring Antriebsritzel	seal, oil, pinion	BN7, BT7, BJ7, BJ8 ohne, w/o OD	1
G44MGA-19	Feder	spring, detent plunger	BN7, BT7, BJ7, BJ8	1
G47AH	Feder Schaltkulisse Rückwärtsgang	spring, plunger	BN7, BT7, BJ7, BJ8	1
G48MGA-19	Kupferscheibe	washer, plug	BN7, BT7, BJ7, BJ8	1
G49AH	Hülse	plunger	BN7, BT7, BJ7, BJ8	1
G49MGA-19	Feder	spring, plunger	BN7, BT7, BJ7, BJ8	1
G61AH	Feder Schaltwelle	spring, ball	BN7, BT7, BJ7, BJ8	3
G61MGA-19	Kugel	ball	BN7, BT7, BJ7, BJ8	A/R
G67AH	Gabel 3. und 4. Gang	fork, 3rd and 4th	BN7, BT7, BJ7, BJ8	1
G77AH	Welle 3.Gang + 4.Gang	shaft, 3rd and 4th selector	BN7, BT7, BJ7, BJ8	1
G78AH	Welle 1.Gang + 2.Gang	shaft, 1th and 2nd selector	BN7, BT7, BJ7, BJ8	1
E107SPT	OD-Schalter an Getriebe	switch, overdrive on gearbox	BN7, BT7, BJ7, BJ8	1
G201AH	Schalthebelgummi	boot, gear lever	BN7, BT7, BJ7, BJ8	1
G206AH	Gummi-Dichtung Ölmesstab Getriebe	grommet, dipstick	BN7, BT7, BJ7, BJ8	2
G208AH	Öldichtring Schaltgestänge	seal, oil	BN7, BT7, BJ7, BJ8	1
G334AH	Haltefeder Schalthebel	spring, ball end retaining	BN7, BT7, BJ7, BJ8	1

Getriebetunnel / Gearbox Covers

S17MGA-02	Ring Schalthebel-Manschette	ring, shift lever grommet	BN7>16039, BT7>15881, BJ7, BJ8	1
i103	Druckknopfunterteil auf Karosserie	snap, male	BN7>16039, BT7>15881, BJ7, BJ8	A/R
G201AH	Schalthebelgummi	boot, gearbox cover	BN7>16039, BT7>15881, BJ7, BJ8	1
i225AH/BJ8	Getriebetunnel GFK	gearbox cover GFK	BN7>16039, BT7>15881, BJ7, BJ8	1
i226AH	Dichtsatz Getriebetunnel	seal set, gearbox cover	BN7>16039, BT7>15881, BJ7, BJ8	1
i227AH/BJ8	Anschlussblech Getriebetunnel	extension panel, gearbox cover	BN7>16039, BT7>15881, BJ7, BJ8	1
i228AH	Aschenbecher	ashtray assembly	BN7>16039, BT7>15881, BJ7, BJ8	1
R240AH/BJ8	Stopfen Getriebetunnel	plug, gearbox cover	BN7>16039, BT7>15881, BJ7, BJ8	1
R241AH/BJ8	Tülle Tachowelle in Getriebetunnel	boot, speedometer cable	BN7>16039, BT7>15881, BJ7, BJ8	1

Getriebebefestigung / Gearbox Mountings

M04MGB-03	Gummilager Getriebehals hinten	mounting, gearbox	BN7, BT7, BJ7, BJ8	2
M05MGB-03	Büchse Schubstrebe	bush, rubber, gearbox rear cover	BN7, BT7, BJ7, BJ8	2
HA23AH	Gummibuchse	bush, rubber, tie rod	BN7, BT7, BJ7, BJ8	2
G110AH-L	Halte Getriebe-Aufhängung links	bracket, mounting LH	BN7, BT7, BJ7, BJ8	1
G110AH-R	Halte Getriebe-Aufhängung rechts	bracket, mounting RH	BN7, BT7, BJ7, BJ8	1
G112AH	Gummiaufhängung Getriebe	rebound rubber	BN7, BT7, BJ7, BJ8	1
G120AH	Getriebe Haltestrebe hinten	tie rod, engine	BN7, BT7, BJ7, BJ8	1
G121AH	Lagerbolzen Anlenkhebel	pin, hinge	BN7, BT7, BJ7, BJ8	1

Getriebe 4-Gang / Internal Gearbox 4 speed
BN2, BN4, BN6, BN7, BT7, BJ7, BJ8

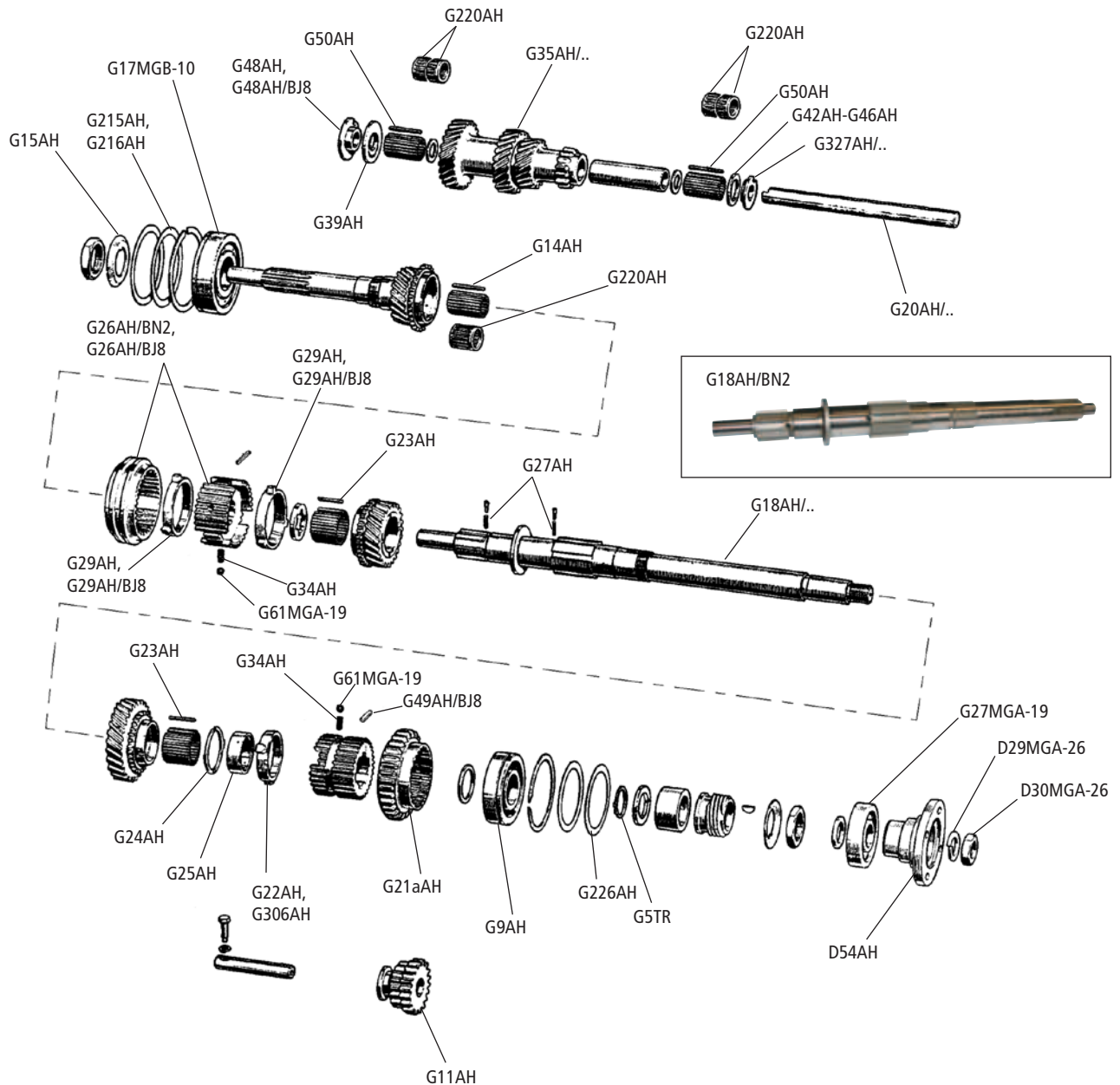

No.	Bezeichnung	Description	Type	Anzahl/Qty.
G3AH	Getriebe Dichtsatz	gasket set, gearbox	BN2, BN4, BN6, BN7, BT7, BJ7, BJ8	1
G5TR	Sicherungsring	circlip	BN2, BN4, BN6, BN7, BT7, BJ7, BJ8 o/d	1
G9AH	Kugellager Getriebe	bearing, mainshaft	BN2, BN4, BN6, BN7, BT7, BJ7, BJ8	1
G11AH	Rückwärtsgangrad (18-14 Zähne)	gear, reverse (18-14 cog)	BN7, BT7, BJ7, BJ8	1
G11AH/BN2	Rückwärtsgangrad (19-14 Zähne)	gear, reverse (19-14 cog)	BN2, BN4, BN6	1
G14AH	Nadel für Nadellager Getriebeeingangswelle	bearing, needle, 1st motion shaft	BN2, BN4, BN6, BN7, BT7, BJ7	A/R
G15AH	Sicherungsblech Getriebewelle	lockwasher	BN2, BN4, BN6, BN7, BT7, BJ7, BJ8	1
G17MGB-10	Lager Getriebe Eingangswelle	bearing, 1st motion shaft	BN2, BN4, BN6, BN7, BT7, BJ7, BJ8	1
G18AH/BN2	Hauptwelle Getriebe Overdrive	mainshaft, overdrive	BN2, BN4, BN6	1
G18AH/BN7	Hauptwelle Getriebe Overdrive	mainshaft, overdrive	BN7 + BT7 < 29D10543	1
G18AH/BJ7	Hauptwelle Getriebe Overdrive	mainshaft, overdrive	BN7, BT7 > 29D 10544 seit.gesch./sideshift; BN7, BT7 Mittelschaltung/centershift, BJ7	1

Getriebe 4-Gang / Internal Gearbox 4 speed BN2, BN4, BN6, BN7, BT7, BJ7, BJ8

No.	Bezeichnung	Description	Type	Anzahl/Qty.
G18AH/BJ8	Hauptwelle Getriebe Overdrive	mainshaft, overdrive	BJ8	1
G21aAH	Gangrad 1.Gang (Aussenteil)	outer ring, first gear	BN2, BN4, BN6, BN7, BT7, BJ7, BJ8	1
G22AH	Synchronring Messing	synchro ring, 2nd	BN2, BN4, BN6	1
G23AH	Nadel für Nadellager	bearing, needle roller	BN2, BN4, BN6, BN7, BT7, BJ7, BJ8	65
G24AH	Ausgleichscheibe 2.Gang	thrustwasher, 2nd gear	BN2, BN4, BN6, BN7, BT7, BJ7, BJ8	1
G25AH	Anlaufplatte 2.Gang	plate, locking	BN2, BN4, BN6, BN7, BT7, BJ7, BJ8	A/R
G26AH/BN2	Synchronnabe 3. + 4. Gang	sliding hub assembly, 3rd & 4th	BN2-BJ8	1
G26AH/BJ8	Synchronnabe 3. + 4. Gang	sliding hub assembly, 3rd & 4th	BJ8	1
G27AH	Feder Gangrad-Einheit	spring, plunger	BN2, BN4, BN6, BN7, BT7, BJ7, BJ8	2
G27MGA-19	Lager Getriebehals	bearing	BN2, BN4, BN6, BN7, BT7, BJ7, BJ8 ohne, w/o OD	1
G29AH	Synchronring 3. + 4. Gang	synchro ring 3rd & 4th	BN2, BN4, BN6, BN7, BT7, BJ7	2
D29MGA-26	Federring 3/4"	washer, locking	BN2, BN4, BN6, BN7, BT7, BJ7, BJ8 ohne, w/o OD	1
D30MGA-26	Mutter 3/4" UNF flach	nut, flange	BN2, BN4, BN6, BN7, BT7, BJ7, BJ8 ohne, w/o OD	1
G34AH	Feder Schaltmuffe	spring, ball	BN2, BN4, BN6, BN7, BT7, BJ7, BJ8	6
G35AH/BN2	Vorgelegezahnkranz überholt (1.Gang/Rückwärtsgang wird ausgetauscht)	laygear, rebuild (1st motion/reverse gear for exchange)	BN2, BN4, BN6	1
G35AH/BT7	Vorgelegezahnkranz	laygear	seitengeschaltet / sideshift BN7,BT7>29D-H14910-1823 non O/D + 29D-H14566-12319 o/d	1
G35aAH/BT7	Vorgelegezahnkranz	laygear	seitengeschaltet / sideshift BN7,BT7>29D-H11342-29DH14909 non o/d + 29D-H10897-29D-H14565 o/d	1
G35AH/BN7	Vorgelegezahnkranz	laygear	seitengeschaltet / sideshift BN7,BT7<29D-H11341 non o/d + BT7<29D-H10886 o/d	1
G35AH/BJ7	Vorgelegezahnkranz	laygear	seitengeschaltet / sideshift BN7,BT7>1824 non o/d + >12320 o/d, BN7+BT7 all center shift, BJ7	1
G35AH/BJ8	Vorgelegezahnkranz	laygear	BJ8	1
G39AH	Anlaufscheibe vorne	thrustwasher, front	BN2, BN4, BN6, BN7, BT7, BJ7, BJ8	1
G42AH	Anlaufscheibe hinten .080"	thrustwasher, rear, .080"	BN7, BT7, BJ7	A/R
G43AH	Anlaufscheibe Vorgelege hinten .080"	thrustwasher, rear .080"	BJ8	A/R
G44AH	Anlaufscheibe Vorgelege hinten .078"	thrustwasher, rear .078"	BJ8	A/R
G45AH	Anlaufscheibe Vorgelege hinten .081"	thrustwasher, rear .081"	BJ8	A/R
G46AH	Anlaufscheibe Vorgelege hinten .085"	thrustwasher, rear .085"	BN2, BN4, BN6, BN7, BT7	1
G48AH	Anlaufscheibe Vorgelege vorne	plate, gear unit thrust, front	BN2, BN4, BN6, BN7, BT7, BJ7	1
G48AH/BJ8	Anlaufscheibe Vorgelege vorne	plate, gear unit thrust, front	BJ8	1
G49AH/BJ8	Hülse	plunger	BJ8	2
G50AH	Nadel für Vorgelegewelle Lagerung	bearing, needle, laygear	BN2, BN4, BN6, BN7, BT7, BJ7	46
D54AH	Flansch	flange, coupling	BN2, BN4, BN6, BN7, BT7, BJ7, BJ8 ohne, w/o OD	1
G61MGA-19	Kugel	ball	BN2, BN4, BN6, BN7, BT7, BJ7, BJ8	3
G215AH	Ausgleich-Scheibe Lager vorne 0.002"	shim, bearing 0.002"	BN2, BN4, BN6, BN7, BT7, BJ7, BJ8	A/R
G216AH	Ausgleich-Scheibe Lager vorne 0.005"	shim, bearing 0.005"	BN2, BN4, BN6, BN7, BT7, BJ7, BJ8	A/R
G220AH	Käfiglager Vorgelege + Hauptwelle	bearing, laygear/caged, 1st motion shaft	BJ8	4/1
G226AH	Scheibe Hauptwelle	shim, bearing	BJ8	A/R
G29AH/BJ8	Synchronring 3. + 4.Gang	synchro ring, 3rd & 4th	BJ8	2
G306AH	Synchronring (Stahl)	synchro ring, 2nd (steel)	BJ8	1
G20AH/BJ8	Vorgelegewelle	layshaft	BJ8	1
G20AH/BN2	Vorgelegewelle	layshaft	BN2, BN4, BN6, BN7, BT7, BJ7	1
G327AH/BN2	Anlaufscheibe Vorgelege hinten	plate, gear unit thrust, rear	BN2, BN4, BN6, BN7, BT7, BJ7	1
G327AH/BJ8	Anlaufscheibe Vorgelege hinten	plate, gear unit thrust, rear	BJ8	1

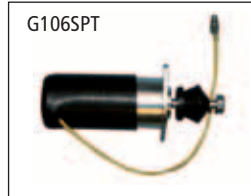
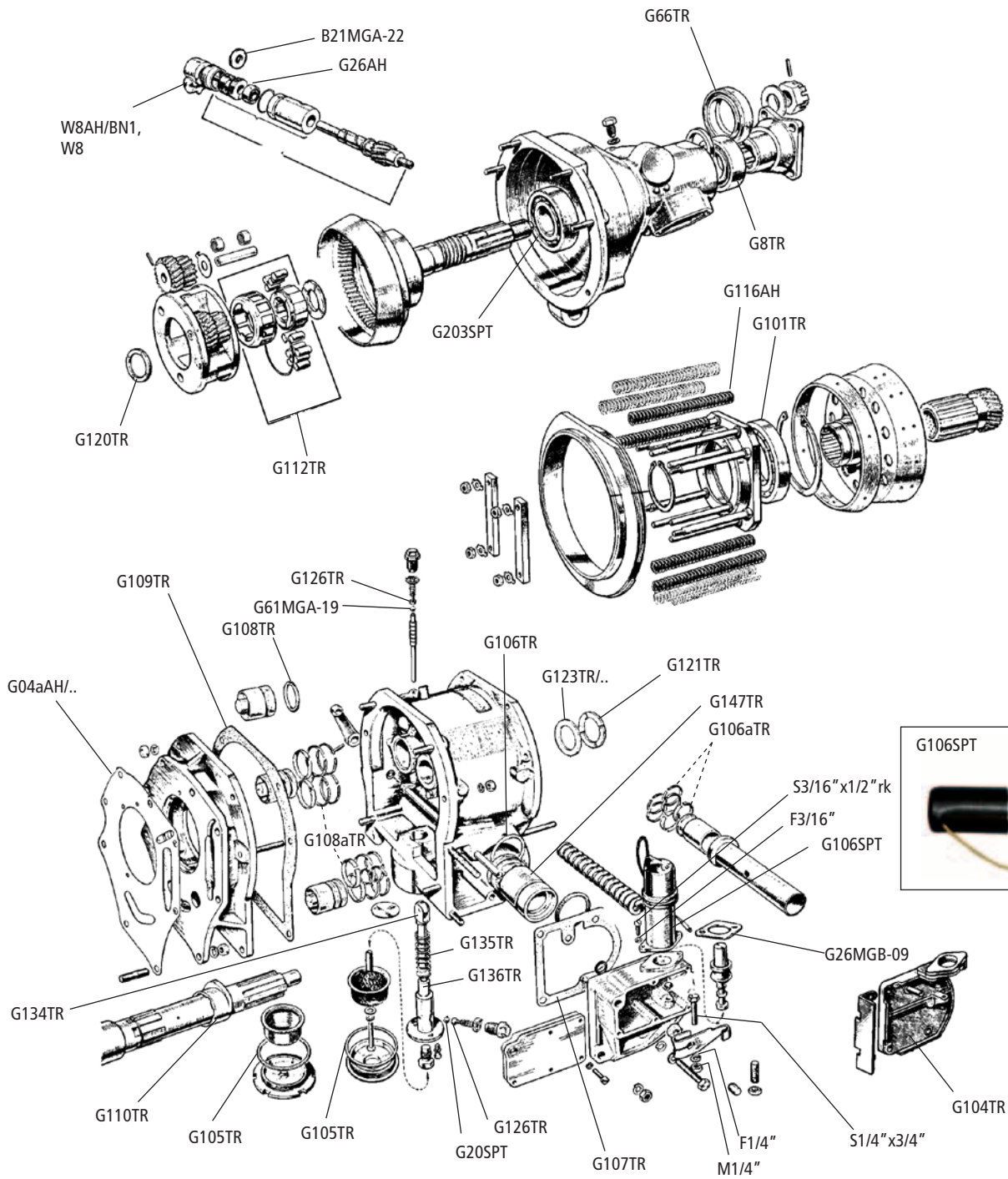

G04AH/BN1



G04AH/BN2



No.	Bezeichnung	Description	Type	Anzahl/Qty.
G3AH	Getriebedichtsatz	gasket set, for gearbox and O/D	BN1, BN2, BN4, BN6, BN7, BT7, BJ7, BJ8	1
G04AH/BN1	AT-Overdrive A-Typ	overdrive, Type A, exchange	BN1	1
G04AH/BN2	AT-Overdrive A-Typ	overdrive, Type A, exchange	BN2, BN4, BN6	1
G04AH/BN7	AT-Overdrive A-Typ	overdrive, Type A, exchange	BN7, BT7, BJ7, BJ8	1
G04aAH/BN1	Dichtung Getriebehals	gasket, overdrive to gearbox	BN1	1
G04aAH/BN2	Dichtung Getriebehals Seitenschaltung	gasket, overdrive to gearbox	BN2, BN4, BN6, BN7, BT7, BJ7	1
G04aAH/BJ8	Dichtung Getriebehals Mittelschaltung	gasket, overdrive to gearbox	BN7, BT7, BJ7, BJ8	1
G8TR	Lager 6206/Getriebelager	bearing, annulus, rear	BN1, BN2, BN4, BN6, BN7, BT7, BJ7, BJ8	1
W8AH/BN1*	Winkelantrieb	adaptor box, speedometer	BN1, BN2	1
W8	Winkelantrieb Tachowelle	adaptor box, speedometer	BN4, BN6, BN7, BT7, BJ7, BJ8	1
W10MGB	Tachowelle	speedometer	BN1, BN2	1
G20SPT	Kugel ø 1/4"	ball 1/4"	BN1, BN2, BN4, BN6, BN7, BT7, BJ7, BJ8	1
B21MGA-22	Kupferscheibe 7/16"	washer, adaptor	BN1, BN2, BN4, BN6, BN7, BT7, BJ7, BJ8	1
G26AH	Dichtring	seal, oil	BN1-BJ8	1
G26MGB-09	Dichtung Magnetschalter	gasket, solenoid to bracket	BN1, BN2, BN4, BN6, BN7, BT7, BJ7, BJ8	1
G61MGA-19	Kugel	ball	BN1, BN2, BN4, BN6, BN7, BT7, BJ7, BJ8	3
G66TR	Simmerring Getriebe hinten	seal, oil	BN1, BN2, BN4, BN6, BN7, BT7, BJ7, BJ8	1
G101TR	Kupplungslager	bearing, thrust ring	BN1, BN2, BN4, BN6, BN7, BT7, BJ7, BJ8	1
G104TR	Deckel Druckspeicher	bracket, solenoid	BN2, BN4, BN6	1
G105TR	Dichtung Ölfilter	washer, fiber	BN1, BN2, BN4, BN6, BN7, BT7, BJ7, BJ8	1
G106SPT	Magnetschalter	solenoid, operating	BN1, BN2, BN4, BN6, BN7, BT7, BJ7, BJ8	1
G106TR	O-Ring Druckspeicherkolben	O ring	BN1, BN2, BN4, BN6, BN7, BT7, BJ7, BJ8	2/1
G106aTR	Satz Kolbenringe Druckspeicher	ring set, piston	BN1, BN2, BN4, BN6, BN7, BT7, BJ7, BJ8	1
G107TR	Dichtung Druckspeicherdeckel	gasket, bracket to casing	BN1, BN2, BN4, BN6, BN7, BT7, BJ7, BJ8	1
G108TR	O-Ring Arbeitskolben	o ring, operating piston	BN7+ BT7> O/D 22/3009/607 BJ7, BJ8	2
G108aTR	Satz Kolbenringe (2x Kolben) für Arbeitskolben	piston ring set (2x piston)	BN1-BN7+BT7<O/D 22/3009/607	4
G109TR	Dichtung Adapterplatte	gasket, palte to casing	BN1, BN2, BN4, BN6, BN7, BT7, BJ7, BJ8	1
G110TR	Antriebsnocken	cam, oil pump	BN1, BN2, BN4, BN6, BN7, BT7, BJ7, BJ8	1
G112TR	Freilauf	assembly, unidirectional clutch	BN1, BN2, BN4, BN6, BN7, BT7, BJ7, BJ8	1
G116AH	Satz Federn (8 Stück) A-Overdrive Kupplung	spring set, clutch	BN1, BN2, BN4, BN6, BN7, BT7, BJ7, BJ8	1
G120TR	Anlaufscheibe Overdrive Sonnenrad hinten	washer, bronze, sunwheel thrust, rear	BN1, BN2, BN4, BN6, BN7, BT7, BJ7, BJ8	1
G121TR	Anlaufscheibe Overdrive Sonnenrad vorne	thrust washerm bronze, sunwheel, front	BN1, BN2, BN4, BN6, BN7, BT7, BJ7, BJ8	1
G126TR	Kolben Öldruckventil	plunger	BN1, BN2, BN4, BN6, BN7, BT7, BJ7, BJ8	1
G134TR	Kolben Ölpumpe	plunger assembly, oil pump	BN1, BN2, BN4, BN6, BN7, BT7, BJ7, BJ8	1
G135TR	Druckfeder Pumpenkolben	spring	BN1, BN2, BN4, BN6, BN7, BT7, BJ7, BJ8	1
G136TR	Gehäuse Ölpumpe	body, oil pump	BN1, BN2, BN4, BN6, BN7, BT7, BJ7, BJ8	1
G147TR	Gehäuse Druckspeicher	housing assembly, accumulator	BN1, BN2, BN4, BN6, BN7, BT7, BJ7, BJ8	1
G123TR/.113	Ausgleichscheibe .113-.114"	washer, sunwheel adjust., front .113-.114"	BN1, BN2, BN4, BN6, BN7, BT7, BJ7, BJ8	A/R
G123TR/.107	Ausgleichscheibe .107-.108"	washer, sunwheel adjust., front .107-.108"	BN1, BN2, BN4, BN6, BN7, BT7, BJ7, BJ8	A/R
G123TR/.101	Ausgleichscheibe .101-.102"	washer, sunwheel adjust., front .101-.102"	BN1, BN2, BN4, BN6, BN7, BT7, BJ7, BJ8	A/R
G123TR/.095	Ausgleichscheibe .095-.096"	washer, sunwheel adjust., front .095-.096"	BN1, BN2, BN4, BN6, BN7, BT7, BJ7, BJ8	A/R
G123TR/.089	Ausgleichscheibe .089-.090"	washer, sunwheel adjust., front .089-.090"	BN1, BN2, BN4, BN6, BN7, BT7, BJ7, BJ8	A/R
G123TR/.083	Ausgleichscheibe .083-.084"	washer, sunwheel adjust., front .083-.084"	BN1, BN2, BN4, BN6, BN7, BT7, BJ7, BJ8	A/R
G123TR/.077	Ausgleichscheibe .077-.078"	washer, sunwheel adjust., front .077-.078"	BN1, BN2, BN4, BN6, BN7, BT7, BJ7, BJ8	A/R
G203SPT	Lager Overdrive Mitte	bearing, annulus, front	BN1, BN2, BN4, BN6, BN7, BT7, BJ7, BJ8	1

* Winkelantrieb für BN1, BN2 nicht mehr lieferbar, benutze W8 + W10MGB / angle drive, speedometer BN1, BN2 no longer available - please use no. W8 + W10MGB

Hinweis /
Note



3 Jahre Garantie auf alle mechanischen Teile unserer AT-Getriebe und AT-Overdrives.

Beachten Sie bitte die Hinweise zu den Austauschgetrieben und - Overdrives auf Seite 23!

3 years guarantee on all mechanical gearbox and overdrive components.

Please refer to our notes "Exchange Parts" on page 23!

BN1 bis BJ8 früh < 26704 / BN1 to early BJ8 < 26704

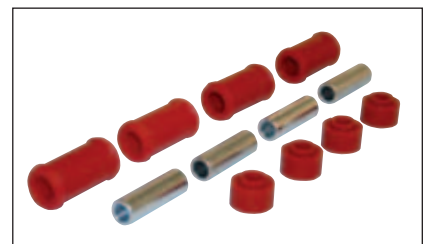
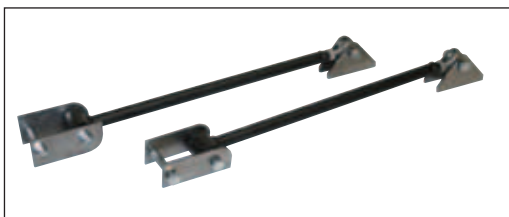
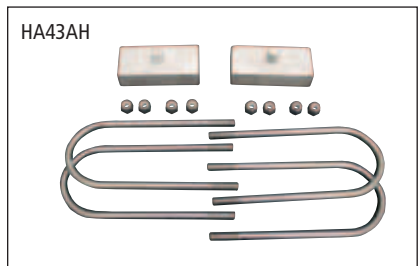
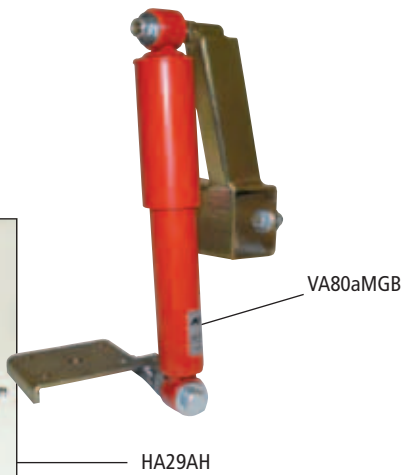
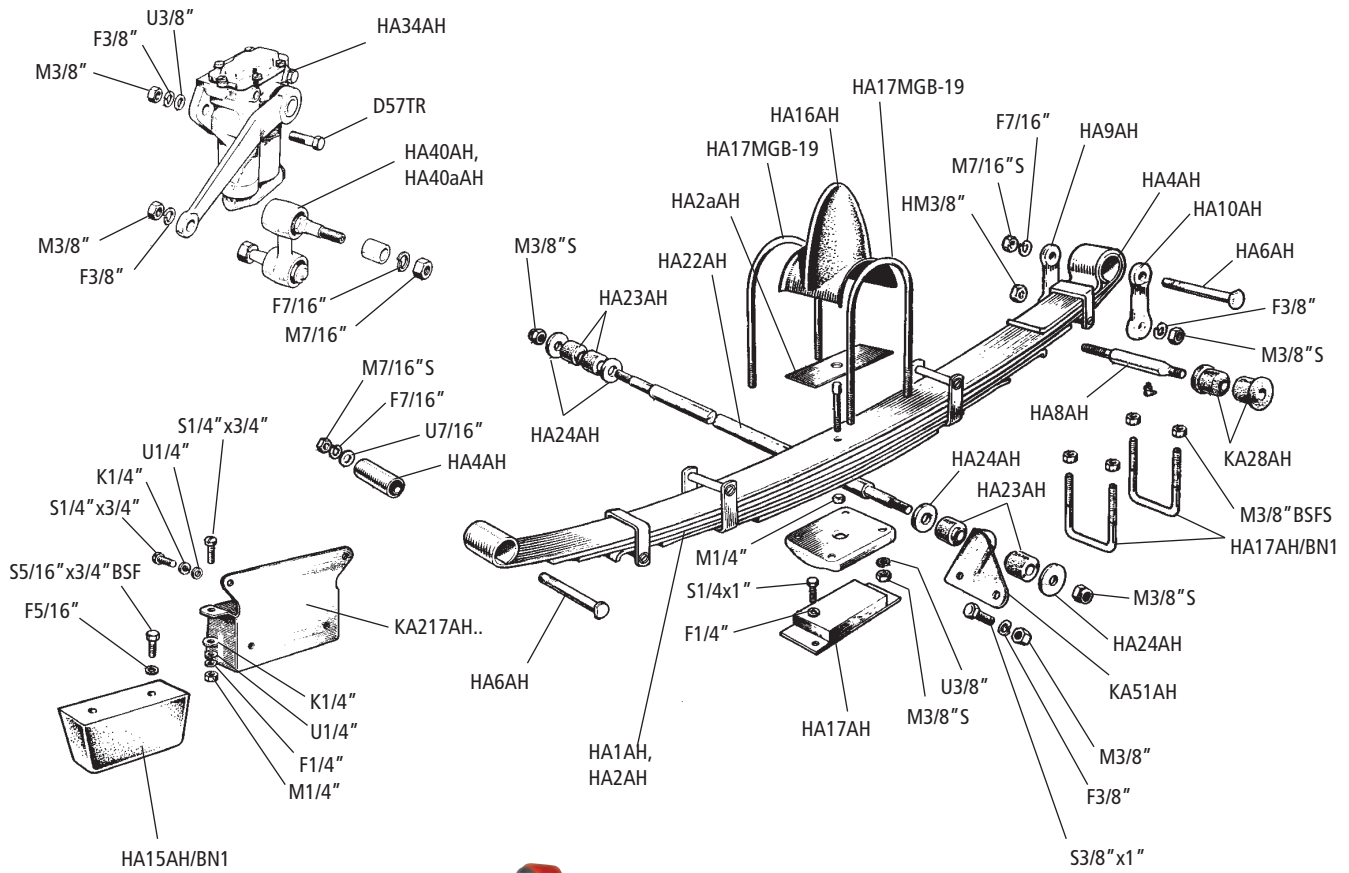



HA50AH

HSD

HA45AH

BN1 bis BJ8 < 26704 früh / BN1 to early BJ8 < 26704

No.	Bezeichnung	Description	Type	Anzahl/Qty.
HA1AH	Blattfeder (7 Blätter)	rear spring (7 leaf)	BN4-BJ8<26704	2
HA1AH/C	Blattfeder verstärkt (8 Blätter)	rear spring, reinforced (8 leaf)	BN4-BJ8<26704	2
HA1AH/RACE	Blattfeder für Motorsportzwecke	rear spring for competition use	BN1-BJ8<26704	2
HA2AH	Blattfeder (8 Blätter)	rear spring (8 leaf)	BN1-BN2	2
HA2aAH	Blattfeder Auflage	rear spring mounting plate	BN1>221536-BJ8<26704	2
HA2aAH/BN1	Blattfeder Auflage, keilförmig	packing piece, fiber	BN1<221535	2
HA4AH	Buchse Blattfederauge vorne	silentbloc bush rear spring front	BN1-BJ8<26704	4
HA6AH	Lagerbolzen	spring bush bolt	BN1-BJ8<26704	4
HA8AH	Lagerstift Blattfeder	shackle pin	BN1-BJ8<26704	2
HA9AH	Halteplatte Blattfeder außen	outer shackle	BN1-BJ8<26704	2
HA10AH	Halteplatte Blattfeder innen	inner shackle	BN1-BJ8<26704	2
HA15AH/BN1	Anschlag Blattfeder oben auf Karosserie.	bump stop box (on body)	BN1<221535	2
HA16AH	Anschlag Blattfeder oben	bump stop top rear spring	BN1>221536-BJ8<26704	2
HA17AH	Anschlag Hinterachse	bump stop rebound	BN1-BJ8<26704	2
HA17AH/BN1	U-Bügel Hinterachse	u-bolt	BN1<221535	4
HA17MGB-19	U-Bügel Hinterachse	u-bolt	BN1>221536-BJ8<26704	4
HA22AH	Panhardstab (ohne Gummi Buchsen)	panhard rod assembly (without bushes)	BN1-BJ8<26704	4
HA23AH	Gummibuchse Panhardstab	rubber bush panhard rod	BN1-BJ8<26704	4
HA23AH/P	Polyurethan Buchse, als Ersatz für HA23AH	polyurethan bush, replaces no. HA23AH	BN1-BJ8<26704	4
HA24AH	Scheibe Panhardstab	washer panhard rod	BN1-BJ8<26704	4
KA28AH	Lagerbuchse Im Rahmen	bush in frame	BN1-BJ8<26704	4
HA29AH/BN1	Umrüstsatz *) Hebelstoßdämpfer auf normale Stoßdämpfer - mit TÜV-Gutachten (ohne Stoßdämpfer VA80aMGB)	servcie kit *) - to fit standard shock absorbers - with TÜV approval (w/o absorber no. VA80aMGB))	BN1<221535	
HA29AH	Umrüstsatz *) Hebelstoßdämpfer auf normale Stoßdämpfer - mit TÜV-Gutachten (ohne Stoßdämpfer VA80aMGB)	servcie kit *) - to fit standard shock absorbers - with TÜV approval (w/o absorber no. VA80aMGB))	BN1>221536-BJ8<26704	
HA34AH/R	Stoßdämpfer hinten rechts	rear shocker right	BN1-BJ8<26704	1
HA34AH/L	Stoßdämpfer hinten links	rear shocker left	BN1-BJ8<26704	1
HA40AH	Stoßdämpferarm	shocker link	BN1>221536-BJ8<26704	2
HA40aAH	Stoßdämpferarm	shocker lin	BN1<221535	2
HA42AH	Befestigungssatz Blattfeder hinten, enthält: 2x HA6AH, 1x HA8AH, 2x HA4AH)	rear spring fitting kit includes: 2x HA6AH, 1x HA8AH, 2x HA4AH)	BN1-BJ8<26704	1
HA43AH/BN1	Tieferlegungssatz	rear lowering kit	BN1<221535	1
HA43AH	Tieferlegungssatz	rear lowering kit	BN1>221536-BJ8<26704	1
HA45AH	Polyurethan Buchsen und Unterlagen Satz	polyurethan bushes and plates ensemble	BN1-BJ8<26704	1
HA50AH	Zusatzstrebe Satz Hinterachse	tramp bar kit	BN1>221536-BJ8<26704	1
KA51AH	Halter Panhardstab	bracket panhard rod	BN1-BJ8<26704	2
D57TR	Bef.-Schraube Stoßdämpfer	bolt rear shocker	BN1-BJ8<26704	4
VA80aMGB	Stoßdämpfer Koni	shock absorber Koni	BN1-BJ8<26704	2
KA217AH/BN1	Blech Anschlaggummi	bump stop box	BN1<221535	2
KA217AH	Blech Anschlaggummi	bump stop box	BN1>21536-BJ8<26704	2
HM3/8"	Mutter Flach	nut flat	BN1-BJ8<26704	2
M3/8"S	Selbstsichernde Mutter	nut nyloc	BN1-BJ8<26704	A/R
M7/16"S	Selbstsichernde Mutter	nut nyloc	BN1-BJ8<26704	A/R
HSD	Hebelstoßdämpferöl 0,5 Liter	shocker oil 0,5 Liter	BN1-BJ8	A/R

*) Montageanleitungen finden Sie auf unseren Internetseiten.

*) Please refer to our mounting instructions on our websites.

BJ8 spät / late BJ8 > 26705

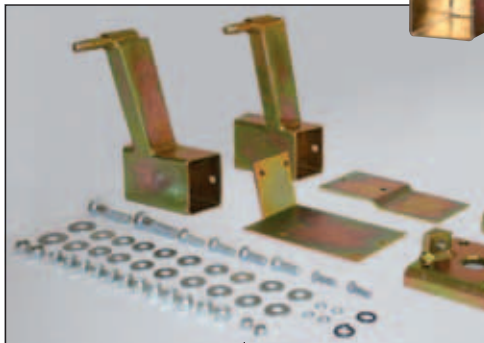
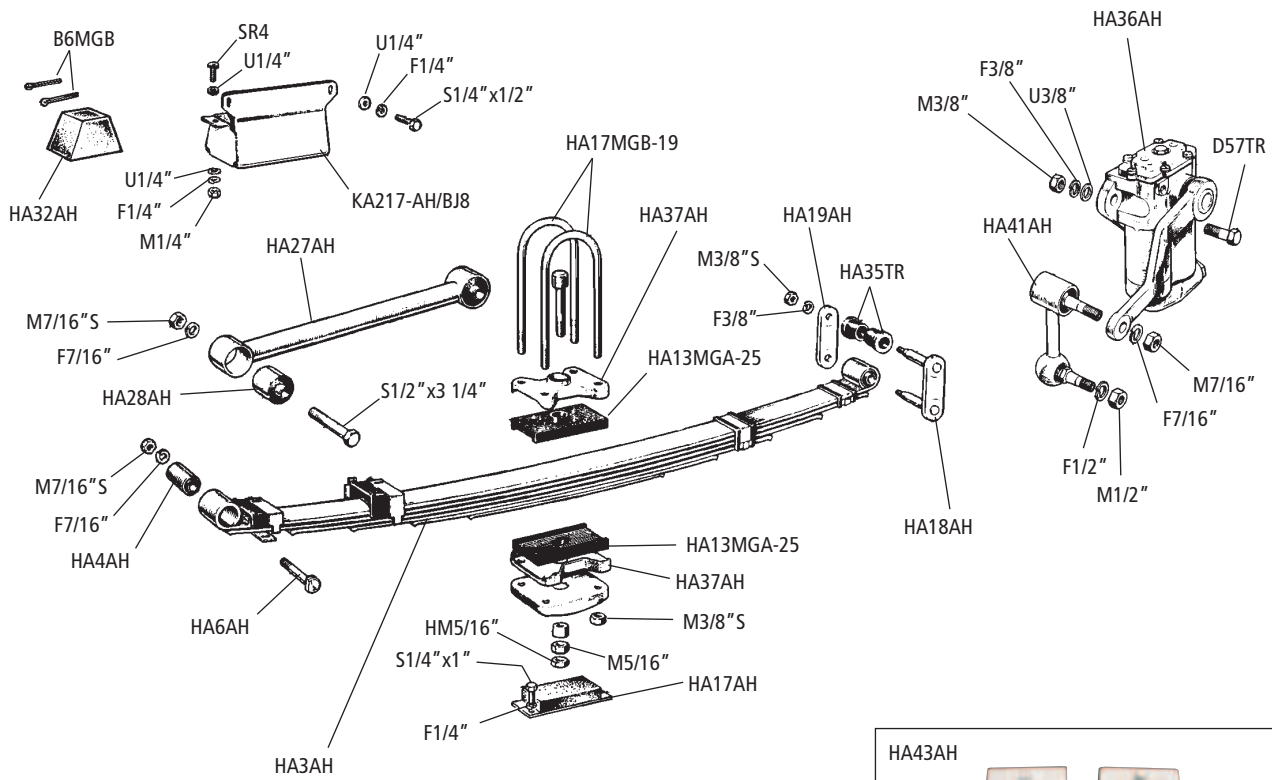

HA29AH/BJ8

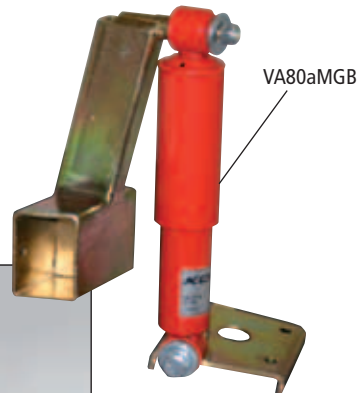

VA80aMGB



HSD

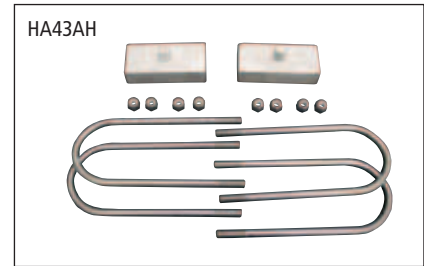

HA43AH

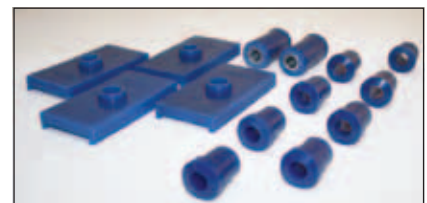

HA45AH/BJ8p

BJ8 spät >26705 / late BJ8 >26705

No.	Bezeichnung	Description	Type	Anzahl/Qty.
HA3AH	Blattfeder (6 Blätter) mit Buchsen	rear spring (6 leaf) with bush	BJ8>26705	2
HA4AH	Buchse Blattfederauge vorne	silentbloc bush rear spring front	BJ8>26705	4
SR4	Rundkopfschraube 1/4"	round-head screw 1/4"	BJ8>26705	4
HA6AH	Lagerbolzen	spring bush bolt with nut	BJ8>26705	2
B6MGB	Splint für Anschlaggummi HA32AH	pin to bump stop no. HA32AH	BJ8>26705	4
HA17AH	Anschlag Hinterachse	bump stop rebound	BJ8>26705	2
HA17MGB-19	U-Bügel Blattfeder hinten	rear shackle assembly	BJ8>26705	2
HA19AH	Halter Blattfeder hinten	rear shackle inne	BJ8>26705	2
HA13MGA-25	Gummiauflage Blattfeder	rear spring pad	BJ8>26705	4
HA27AH	Schubstrebe hinten	radius arm assy	BJ8>26705	2
HA28AH	Silentgummi	bush	BJ8>26705	4
HA29AH/BJ8	Umrüstsatz *) Hebelstoßdämpfer auf normale Stoßdämpfer - mit TÜV-Gutachten (ohne Stoßdämpfer VA80aMGB)	servcie kit *) - to fit standard shock absorbers - with TÜV approval (w/o absorber no. VA80aMGB)	BJ8>26705	1
				
HA32AH	Anschlaggummi	rear bump stop rubber	BJ8>26705	2
HA35TR	Gummibuchse Federaufhängung	shackle plate bush	BJ8>26705	8
HA36AH/R	Stoßdämpfer hinten rechts	rear shocker right	BJ8>26705	1
HA36AH/L	Stoßdämpfer hinten links	rear shocker left	BJ8>26705	1
HA37AH	Zentrierplatte Blattfeder	plate locating	BJ8>26705	4
HA41AH	Stoßdämpferarm	shocker link	BJ8>26705	2
HA43AH	Tieferlegungssatz (beidseitig) denkbar einfachste Montage, die eine Tieferlegung des Fahrzeugs um ca. 2,5 cm erbringt	lowering bock kit (both sides) absolutely easy to install, allows lowering of the car about 2,5 cm	BJ8>26705	1
HA45AH/BJ8p	Polyurethan Buchsen und Unterlagen Satz	polyurethan bushes and plates ensemble	BJ8>26705	1
VA80aMGB	Stoßdämpfer Koni	shock absorber Koni	BJ8>26705	2
KA217-AH/BJ8	Anschlagkasten Blattfeder oben auf Karosserie	bump stop box on body	BJ8>26705	2
HSD	Hebelstoßdämpferöl 0,5 Liter	shocker oil 0,5 Litre	BJ8>26705	A/R

*) Montageanleitungen finden Sie auf unseren Internetseiten.

*) Please refer to our mounting instructions on our websites.

Hinterachse BN1 früh / Rear axle early BN1
Spiral Bevel Type < 221535

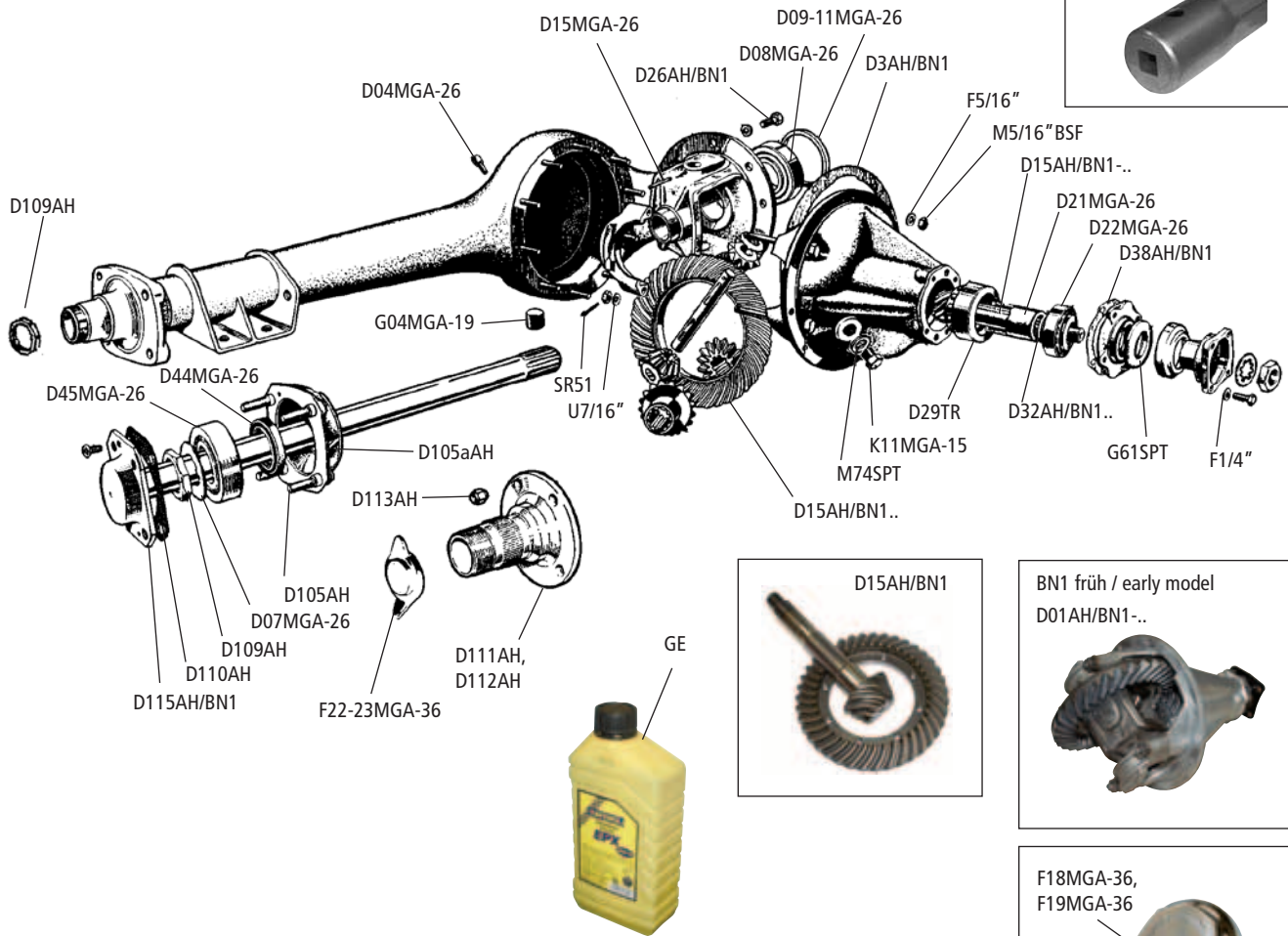

Kardanwelle / Propshaft BN1-BJ8

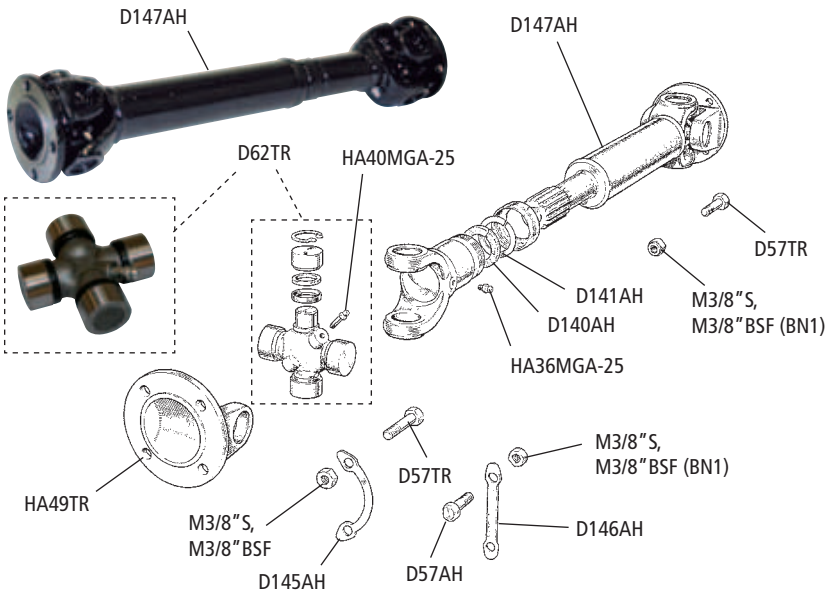

Hinweis: Bei 100/4, BN1- Modellen sind ausschließlich BSF Bolzen und Schrauben montiert worden. Die nicht lieferbaren BSF-Bolzen sind problemlos gegen die UNF-Bolzen und -Mutter der Nachfolgemodelle austauschbar.

Please note that on 100/4 BN1-models the threads used have been almost exclusively B.S.F. For the BSF-bolts and -nuts which are NLA you can use the UNF-bolts and -nuts from the late models.

BN1 früh < 221535 / early BN1 < 221535 (Spiral bevel type)

No.	Bezeichnung	Description	Type	Anzahl/Qty.
D01AH/BN1-3.6	AT-Differential 3.600	differential, exchange 3.600	BN1<221535	1
D01AH/BN1-4.1	AT-Differential 4.100	differential, exchange 4.100	BN1<221535	1
D3AH/BN1	Dichtung	gasket	BN1<221535	1
G04MGA-19	Einfüll/Ablass-Stopfen	oil drain/filler plug	BN1<221535	1
D04MGA-26	Entlüftungsventil	breather	BN1<221535	1
D07MGA-26	Sicherungsscheibe	lockwasher	BN1<221535	2
D08MGA-26	Lager Abtriebsseite	bearing carrier	BN1<221535	2
D09MGA-26	Ausgleichsscheibe 0.002"	shim 0.002"	BN1<221535	A/R
D10MGA-26	Ausgleichsscheibe 0.003"	shim 0.003"	BN1<221535	A/R
D11MGA-26	Ausgleichsscheibe 0.006"	shim 0.006"	BN1<221535	A/R
K11MGA-15	Einfüllstopfen	plug filler	BN1<221535	1
D15AH/BN1-3.6	Teller + Kegelrad 9/33 (3.666:1)	pinion & crown wheel 9/33 (3.666:1)	BN1<221535	1
D15AH/BN1-4.1	Teller + Kegelrad 8/33 (4.125:1)	pinion & crown wheel 8/33 (4.125:1)	BN1<221535	1
D15MGA-26	Sicherungsstift	plug	BN1<221535	1
F18MGA-36	8-Kantmutter 12 Tpi RH	octagon wheel nut 12 tpi RH	BN1<221535	2
F19MGA-36	8-Kantmutter 12 Tpi LH	octagon wheel nut 12 tpi LH	BN1<221535	2
F22MGA-36	2-zackige Flügelmutter 12 Tpi RH	2-earried wheel nut 12 tpi RH	BN1<221535	2
F23MGA-36	2-zackige Flügelmutter 12 Tpi LH	2-earried wheel nut 12 tpi LH	BN1<221535	2
F24MGA-36	3-zackige Flügelmutter 12 Tpi RH	3-earried wheel nut 12 tpi RH	BN1<221535	2
F25MGA-36	3-zackige Flügelmutter 12 Tpi LH	3-earried wheel nut 12 tpi LH	BN1<221535	2
D21MGA-26	Distanzstück	spacer bearing	BN1<221535	1
D22MGA-26	Lager Kegelrad außen	bearing pinion front	BN1<221535	1
D29TR	Lager Kegelrad innen	bearing pinion rear	BN1<221535	1
D26AH/BN1	Befestigungsschraube Tellerrad	screw ring gear to case	BN1<221535	8
D32AH/BN1.003	Ausgleichsscheibe 0.003"	shim 0.003"	BN1<221535	A/R
D32AH/BN1.005	Ausgleichsscheibe 0.003"	shim 0.005"	BN1<221535	A/R
D38AH/BN1	Dichtung Simmerringgehäuse	gasket	BN1<221535	1
D44MGA-26	Simmerring	oil seal	BN1<221535	2
D45MGA-26	Radlager	wheel bearing	BN1<221535	2
SR51	Splint	cotter pin	BN1<221535	4
G61SPT	Simmerring Differential-Eingang	oil seal	BN1<221535	1
M74SPT	Dichtring	washer	BN1<221535	1
D105AH	Radbolzen	stud	BN1<221535	8
D105aAH	Radflansch	rear hub	BN1<221535	2
D109AH	Mutter	nut	BN1<221535	2
D110AH	Dichtung	gasket axle shaft	BN1<221535	2
D111AH	Speichenradadapter LH	hub extension LH	BN1<221535	1
D112AH	Speichenradadapter RH	hub extension RH	BN1<221535	1
D113AH	Mutter	nut	BN1<221535	8
D115AH/BN1	Steckachse	half shaft	BN1<221535	2
D300MGA	Schlüssel für Radflanschnutter	rear hub nut socket	BN1<221535	1
GE	Hypoid Getriebe- / Differentialöl SAE80W90, pro Liter	Hypoid gearbox/differential oil SAE80W90, per liter		A/R

Kardanwelle / Propshaft BN1-BJ8

HA36MGA-25	Schmiernippel Kardanwelle	grease nipple propeller shaft	BN1-BJ8	1
HA40MGA-25	Schmiernippe „lang“ Kreuzgelenk	grease nipple, long	BN1-BJ8	1
D57TR	Bolzen Kardanwelle 3/8" UNF	bolt propshaft 3/8" UNF	BN1-BJ8	4
D57AH	Bolzen Kardanwelle 3/8" UNF, Spezialkopf mit einer Flachseite	bolt propshaft 3/8" UNF, special head	BN1-BJ8	4
D62TR	Kreuzgelenk	U-joint	BN1-BJ8	2
D140AH	Schutzscheibe (Kork)	washer dust cap (cork)	BN2-BJ8	1
D141AH	Schutzscheibe (Stahl)	washer dust cap (steel)	BN1	1
D145AH	Sicherungsblech gebogen (Getriebe o. Overdrive)	lockwasher curved (gearbox no overdrive)	BN4-BJ8	4
D146AH	Sicherungsblech gerade (Getriebe Overdrive)	lockwasher straight (gearbox overdrive)	BN1-BJ8	4
D147AH	Kardanwelle 30" (762mm)	propshaft 30" (762mm)	BN1-BJ8	1
M3/8"BSF	Mutter 3/8" BSF	nut 3/8" BSF	BN1>221535	8
M3/8"S	Selbstsichernde Mutter 3/8"	nut nyloc 3/8"	BN1<221536, BN2-BJ8	8

Hinweis /
NoteBeachten Sie bitte auch die Hinweise zu den
Austauschdifferenzialen auf S. 93 und S. 23!Please refer to our notes "Differential" and
"Exchange Parts" on page 93 and 23!

Hinterachse / Rear axle Hypoid Type
BN1>221536-BJ8

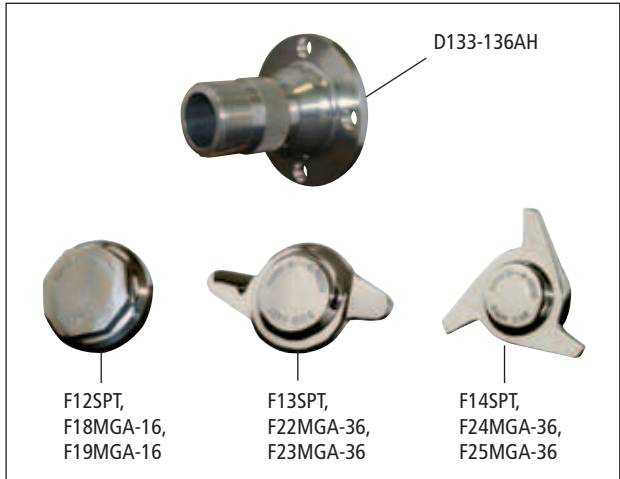
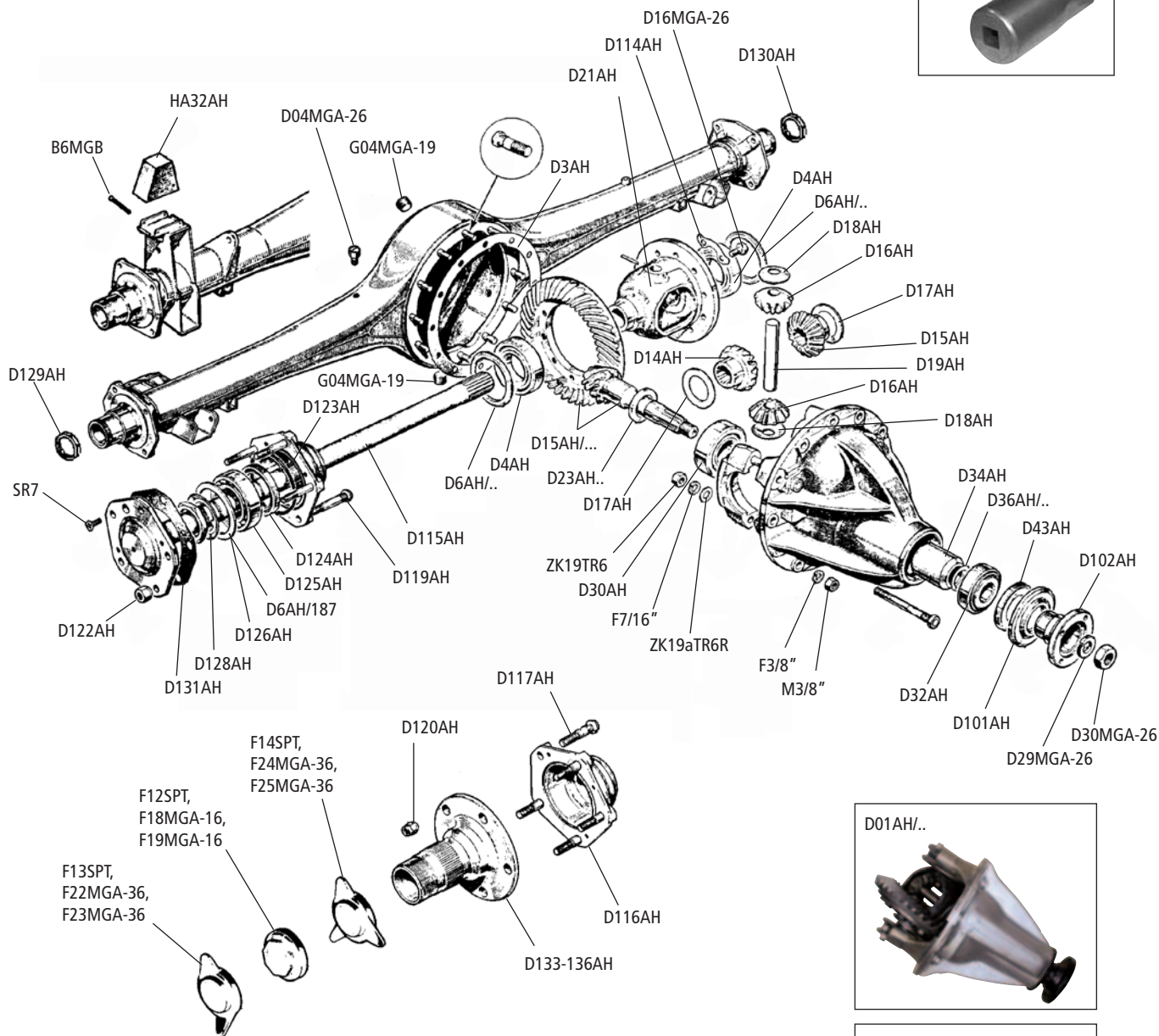

BN1 > 221536-BJ8 / BN1 > 221536-BJ8 (Hypoid Type)

No.	Bezeichnung	Description	Type	Anzahl/Qty.
D01AH/3.545	AT-Differential 3.545	differential, exchange 3.545	BN1>221536-BJ8	1
D01AH/3.909	AT-Differential 3.909	differential, exchange 3.909	BN1>221536-BJ8	1
D01AH/4.1	AT-Differential 4.100	differential, exchange 4.100	BN1>221536-BJ8	1
D01AH/4.375	AT-Differential 4.375	differential, exchange 4.375	BN1>221536-BJ8	1
G04MGA-19	Einfüll/Ablaß-Stopfen Differential	oil drain/filler plug differential	BN1>221536-BJ8	2
D04MGA-26	Entlüftung Differential	breather differential	BN1>221536-BJ8	1
D3AH	Dichtung Differential	differential gasket	BN1>221536-BJ8	1
D4AH	Differentiallager	bearing differential	BN1>221536-BJ8	2
B6MGB	Haltestift	cotter pin	BJ8>26705	4
D6AH/193	Ausgleichsscheibe Lager .193"	shim differential bearing .193"	BN1>221536-BJ8	A/R
D6AH/191	Ausgleichsscheibe Lager .191"	shim differential bearing .191"	BN1>221536-BJ8	A/R
D6AH/187	Ausgleichsscheibe Lager .187"	shim differential bearing .187"	BN1>221536-BJ8	A/R
D6AH/185	Ausgleichsscheibe Lager .185"	shim differential bearing .185"	BN1>221536-BJ8	A/R
D6AH/183	Ausgleichsscheibe Lager .183"	shim differential bearing .183"	BN1>221536-BJ8	A/R
D6AH/181	Ausgleichsscheibe Lager .181"	shim differential bearing .181"	BN1>221536-BJ8	A/R
D6AH/179	Ausgleichsscheibe Lager .179"	shim differential bearing .179"	BN1>221536-BJ8	A/R
D6AH/177	Ausgleichsscheibe Lager .177"	shim differential bearing .177"	BN1>221536-BJ8	A/R
D6AH/175	Ausgleichsscheibe Lager .175"	shim differential bearing .175"	BN1>221536-BJ8	A/R
D15AH/4.1	Teller + Kegelrad 4.100: 1	crown wheel + pinion 4.100: 1	BN1>221536-BJ8	1
D15AH/3.901	Teller + Kegelrad 3.909: 1	crown wheel + pinion 3.909: 1	BN1>221536-BJ8	1
D15AH/3.545	Teller + Kegelrad 3.545: 1	crown wheel + pinion 3.545: 1	BN1>221536-BJ8	1
D15AH/4.375	Teller + Kegelrad 4.375: 1	crown wheel + pinion 4.375: 1	BN1>221536-BJ8	1
D14AH	Ausgleichsrad Differential	gear pinion	BN1>221536-BJ8	2
D16AH	Ausgleichsrad Differential	gear pinion	BN1>221536-BJ8	2
D16MGA-26	Bolzen Tellerrad	bolt crown wheel to case	BN1>221536-BJ8	10
D17AH	Anlaufscheibe Planetenrad	differential gear thrust washer	BN1>221536-BJ8	2
D18AH	Anlaufscheibe Kegelrad	differential gear thrust washer	BN1>221536-BJ8	2
D19AH	Lagerstift Planetenräder	pinion centre pin	BN1>221536-BJ8	1
ZK19TR6	Mutter hochfest 7/16"	nut reinforced 7/16"	BN1>221536-BJ8	4
ZK19aTR6R	Scheibe 7/16"	washer plain 7/16"	BN1>221536-BJ8	4
D21AH	Korb	cage differential	BN1>221536-BJ8	1
D23AH/220	Anlaufscheibe Kegelrad .220"	thrust washer pinion .220"	BN1>221536-BJ8	A/R
D23AH/218	Anlaufscheibe Kegelrad .218"	thrust washer pinion .218"	BN1>221536-BJ8	A/R
D23AH/216	Anlaufscheibe Kegelrad .216"	thrust washer pinion .216"	BN1>221536-BJ8	A/R
D23AH/214	Anlaufscheibe Kegelrad .214"	thrust washer pinion .214"	BN1>221536-BJ8	A/R
D23AH/212	Anlaufscheibe Kegelrad .212"	thrust washer pinion .212"	BN1>221536-BJ8	A/R
D23AH/210	Anlaufscheibe Kegelrad .210"	thrust washer pinion .210"	BN1>221536-BJ8	A/R
D23AH/208	Anlaufscheibe Kegelrad .208"	thrust washer pinion .208"	BN1>221536-BJ8	A/R
D29MGA-26	Federring	washer, locking	BN1>221536-BJ8	1
D30MGA-26	Mutter Kegelrad	nut pinion	BN1>221536-BJ8	1
D30AH	Lager Kegelrad Ritzel	rear pinion bearing	BN1>221536-BJ8	1
HA32AH	Anschlaggummi	rear bump stop rubber	BJ8>26705	2
D32AH	Lager Differential Antrieb	front pinion bearing	BN1>221536-BJ8	1
D34AH	Abstandshalter	spacer pinion bearing	BN1>221536-BJ8	1
D36AH/004	Scheibe Lager Kegelrad .004"	shim pinion bearing .004"	BN1>221536-BJ8	1
D36AH/006	Scheibe Lager Kegelrad .006"	shim pinion bearing .006"	BN1>221536-BJ8	1
D36AH/008	Scheibe Lager Kegelrad .008"	shim pinion bearing .008"	BN1>221536-BJ8	1
D36AH/010	Scheibe Lager Kegelrad .010"	shim pinion bearing .010"	BN1>221536-BJ8	1
D36AH/012	Scheibe Lager Kegelrad .012"	shim pinion bearing .012"	BN1>221536-BJ8	1
D36AH/020	Scheibe Lager Kegelrad .020"	shim pinion bearing .020"	BN1>221536-BJ8	1
D36AH/030	Scheibe Lager Kegelrad .030"	shim pinion bearing .030"	BN1>221536-BJ8	1
D43AH	Simmerring Differential-Eingang	pinion oil seal	BN1>221536-BJ8	1

- Fortsetzung siehe nächste Seite

- to be continued on next page

Hinweis /
NoteBeachten Sie bitte auch die Hinweise zu den
Austauschdifferentialen auf S. 93 und S. 23!Please refer to our notes "Differential" and
"Exchange Parts" on page 93 and 23!

Hinterachse / Rear axle Hypoid Type
BN1>221536-BJ8

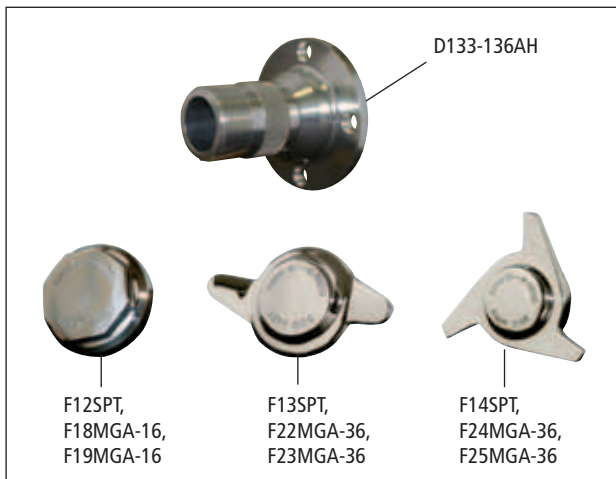
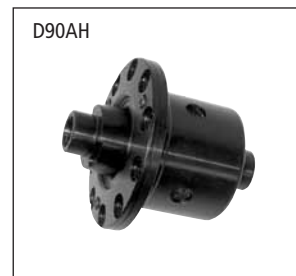
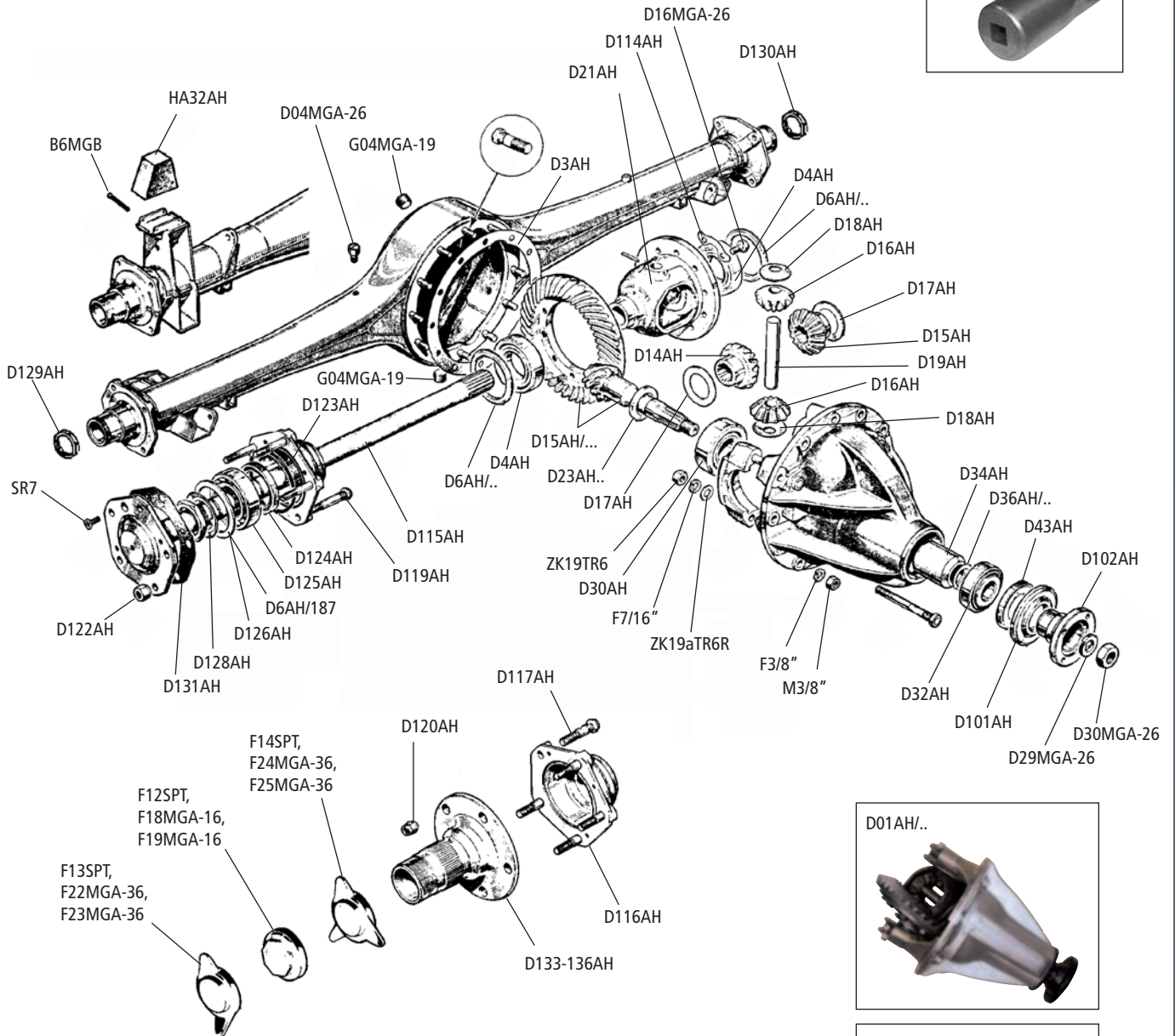

BN1 > 221536-BJ8 / BN1 > 221536-BJ8 (Hypoid Type)

No.	Bezeichnung	Description	Type	Anzahl/Qty.
SR7	Senkkopfschraube	countersunk screw	BN2-BJ8	2
F12SPTR	8-Kantmutter rechts (Grobgewinde 8 tpi)	octagon wheel nut right (coarse thread 8 tpi)	BJ8>26705	2
F12SPTL	8-Kantmutter links (Grobgewinde 8 tpi)	octagon wheel nut left (coarse thread 8 tpi)	BJ8>26705	2
F13SPTR	2-zackige Flügelmutter rechts (Grobgew. 8 tpi)	2-earried wheel nut right (coarse thread 8 tpi)	BJ8>26705	2
F13SPTL	2-zackige Flügelmutter links (Grobgew. 8 tpi)	2-earried wheel nut left (coarse thread 8 tpi)	BJ8>26705	2
F14SPTR	3-zackige Flügelmutter rechts (Grobgew. 8 tpi)	3-earried wheel nut right (coarse thread 8 tpi)	BJ8>26705	2
F14SPTL	3-zackige Flügelmutter links (Grobgew. 8 tpi)	3-earried wheel nut left (coarse thread 8 tpi)	BJ8>26705	2
F18MGA-36	8-Kantmutter rechts (Feingewinde 12 tpi)	octagon wheel nut right (fine thread 12 tpi)	BN1>221336-BJ8<26704	2
F19MGA-36	8-Kantmutter links (Feingewinde 12 tpi)	octagon wheel nut left (fine thread 12 tpi)	BN1>221336-BJ8<26704	2
F22MGA-36	2-zackige Flügelmutter rechts (Feingew./12 tpi)	2-earried wheel nut right (fine thread 12 tpi)	BN1>221336-BJ8<26704	2
F23MGA-36	2-zackige Flügelmutter links (Feingew./12 tpi)	2-earried wheel nut left (fine thread 12 tpi)	BN1>221336-BJ8<26704	2
F24MGA-36	3-zackige Flügelmutter rechts (Feingew./12 tpi)	3-earried wheel nut right (fine thread 12 tpi)	BN1>221336-BJ8<26704	2
F25MGA-36	3-zackige Flügelmutter links (Feingew./12 tpi)	3-earried wheel nut left (fine thread 12 tpi)	BN1>221336-BJ8<26704	2
D30MGA-26	Mutter Hinterachse	nut pinion flange	BN1>221536-BJ8	1
D90AH	Differentialsperre	differential lock	BN1>221536-BJ8	1
D101AH	Schutzkappe Simmerring Differential	dust cover pinion oil seal	BN1>221536-BJ8	1
D102AH	Ausgangsflansch	flange	BN1>221536-BJ8	1
D114AH	Sicherungsblech Tellerrad	washer crown wheel	BN1>221536-BJ8	5
D115AH	Antriebswelle	axle shaft	BN1>221536-BJ8	2
D116AH	Radflansch (Speichenrad)	rear hub (wire wheel)	BN7-BT7-BJ8	2
D117AH	Radbolzen Speichenrad	wire wheel hub stud	BN1>221536-BJ8	10
D119AH	Radbolzen Stahlfelge	stud disc wheel	BN4-BJ8	10
D120AH	Mutter Speichenradadapter	wire wheel adapter nut	BN1>221536-BJ8	10
D122AH	Radmutter Stahlfelge	wheel nut disc wheel	BN4-BJ8	10
D123AH	O-Ring Hinterachse	o-ring half shaft	BN1>221536-BJ8	2
D124AH	Simmerring Hinterachse seitlich	oil seal rear hub	BN1>221536-BJ8	2
D125AH	Radlager Hinterachse	rear hub bearing	BN1>221536-BJ8	2
D126AH	Abstandshalter Radlager	spacer rear hub bearing	BN7-BT7-BJ8	2
D128AH	Sicherungsblech Radflansch	washer rear axle hub nut	BN2-BJ8	2
D129AH	Mutter Radflansch <Achse rechts	nut hub >rear axle tube right	BN1>228012-BJ8	1
D130AH	Mutter Radflansch <Achse links	nut hub >rear axle tube left	BN1>228012-BJ8	1
D131AH	Dichtung Antriebswelle	half shaft gasket	BN1>221536-BJ8	2
D133AH	Speichenradnabe hinten rechts 12 tpi	rear wire wheel hub right 12 tpi	BN1>221536-BJ8<26704	1
D134AH	Speichenradnabe hinten links 12 tpi	rear wire wheel hub left 12 tpi	BN1>221536-BJ8<26704	1
D135AH	Speichenradnabe hinten rechts 8 tpi	rear wire wheel hub right 8 tpi	BJ8>26705	1
D136AH	Speichenradnabe hinten links 8 tpi	rear wire wheel hub left 8 tpi	BJ8>26705	1
D300AH	Schlüssel für Radflanschnutter	rear hub nut socket	BN1>228012-BJ8	1
GE	Hypoid Getriebe- / Differentialöl SAE80W90, pro Liter	Hypoid gearbox/differential oil SAE80W90, per liter		A/R

Hinweis /
Note



3 Jahre Garantie auf alle mechanischen Teile unserer AT-Differenziale.

Beachten Sie bitte die Hinweise zu den Austauschgetrieben und - Overdrives auf Seite 23!

3 years guarantee on all mechanical differential components.

Please refer to our notes "Exchange Parts" on page 23!

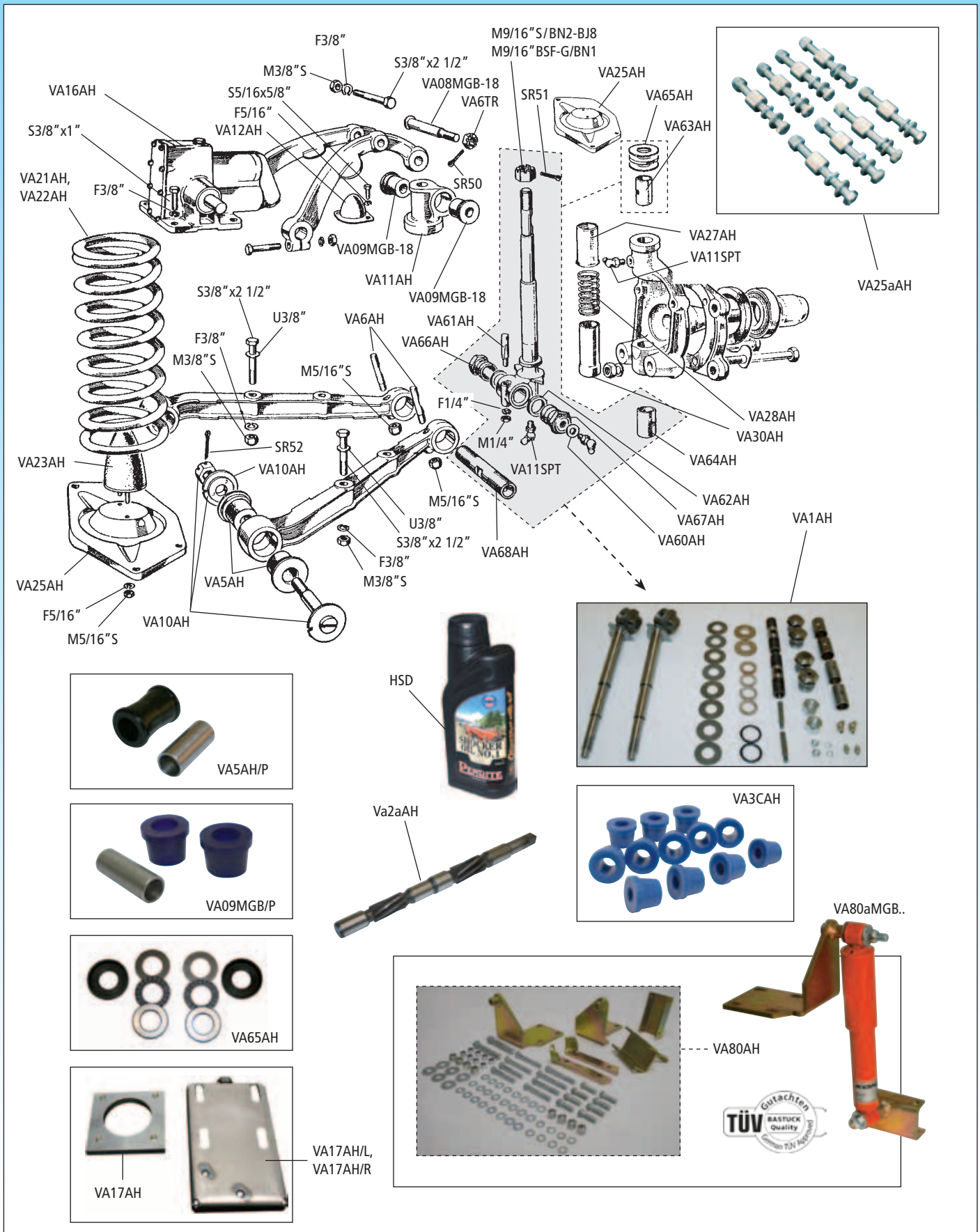

Hinweis: Bitte beachten Sie, dass bei den Modellen 100/4 (BN1 bis Fgst.-Nr. 221403) fast ausschließlich Schrauben und Muttern mit B.S.F. Gewinde verwendet wurden. Die angegebenen Schrauben und Muttern in der Illustration beziehen sich auf BN2-BJ8 Modelle mit UNF Gewinde! – B.S.F. Schrauben und Muttern finden Sie in der separaten Auflistung auf S. 226-227.

Please note that on 100/4 models (BN1 up to chassis number 221403) the threads used have been almost exclusively B.S.F. The nuts and bolts referred to in the illustration are for the later BN2-BJ8 models with UNF thread!
- You will find details of the B.S.F nuts and bolts in a separate list on page 226-227.

No.	Bezeichnung	Description	Type	Anzahl/Qty.
VA1AH	Überholersatz Vorderachse beidseitig (enthält: Überholersatz Achsschenkel beide Seiten, 4x VA09MGB-18, 2x VA70MGB, 8x VA5AH, 4x VA6AH)	front suspension repair kit - both sides (includes: king pin set (both sides), 4x VA09MGB-18, 2x VA70MGB, 8x VA5AH, 4x VA6AH)	BN1-BJ8	1
VA3CAH	Polyurethan Buchsensatz Vorderachse und Schubstreben	set polyurethan bushes front axle and radius arm	BN1-BJ8	1
VA5AH	Gummilager Vorderachse innen	rubber bush inner wishbone	BN1-BJ8	8
VA5AH/P	Polyurethan Buchsensatz Vorderachse innen	set polyurethan bushes front axle, inner	BN1-BJ8	4
VA6AH	Haltestift Lagerbuchse + Mutter	cotter fulcrum pin + nut	BN1-BJ8	4
VA6TR	Kronenmutter Achsschenkelbolzen	crown nut king pin bolt	BN1-BJ8	2
VA08MGB-18	Bolzen Achsschenkel oben	pin, fulcrum, link to shocker	BN1-BJ8	2
VA09MGB-18	Lagerbuchse	bush bearing	BN1-BJ8	4
VA09MGB/P	Polyurethan Buchsensatz oben	set polyurethan bushes, upper	BN1-BJ8	2
VA10AH	Lagerbolzen Achsschenkel unten	inner lower wishbone pin	BN1-BJ8	4
VA11AH	Schwenklager oben	top trunnion	BN1-BJ8	2
VA11SPT	Schmiernippel UNF	grease nipple UNF	BN2-BJ8	4
VA12AH	Anschlaggummi	rebound rubber	BN1-BJ8	2
VA16AH	Stoßdämpfer vorne	front shocker	BN1-BJ8	2
VA17AH	Schiebeplatte Sturzeinstellung	front shock sliding plate	BN1-BJ8	2
VA17AH/L	Stoßdämpfer Halteplatte links mit Langlöchern (muss eingeschweißt werden)	bracket shock absorber LH with slotted holes (must be weld in)	BN1-BJ8	1
VA17AH/R	Stoßdämpfer Halteplatte rechts mit Langlöchern (muss eingeschweißt werden)	bracket shock absorber RH with slotted holes (must be weld in)	BN1-BJ8	1
VA21AH	Spiralfeder vorne	front spring	BN4-BJ8	2
VA22AH	Spiralfeder vorne	front spring	BN1-BN2	2
VA23AH	Anschlagkegel Vorderachse	front axle bump rubber	BN1-BJ8	2
VA25AH	Teller Spiralfeder vorne	front spring pan	BN1-BJ8	1
VA25aAH	Tieferlegungsset Vorderachse (1,5 - 2,0 cm), beidseitig (bestehend aus Distanzbuchsen und längeren Schrauben zu Unterlegung des Tellers der Spiralfedern; einfachste Montage)	lowering set frontaxle (1,5 - 2,0 cm), does both sides (consist of bushes and longer screws to fit underneath the front spring pan; absolutely easy to mount)	BN1-BJ8	1
V25bAH	Tieferlegungsset vorne in Verbindung mit VA80AH	lowering set front axle (with VA80AH)	BN1-BJ8	1
VA27AH	Staubschutzhohr oben	top dust tube	BN1-BJ8	2
VA28AH	Feder	spring	BN1-BJ7<21766	2
VA30AH	Fettkappe Achsschenkel unten	dust excluder bottom king pin	BN4-BJ8	2
VA40AH/R	Halteplatte Stabilisator rechts	fitting plate roll-bar link right	BN1-BJ8	1
VA40AH/L	Halteplatte Stabilisator links	fitting plate roll-bar link left	BN1-BJ8	1
VA45AH	Satz (4) Nyotron Lagerbuchsen oben ermöglicht Sturzeinstellung negativ	set (4) Nyotron bush bearing, upper (to submite negative wheel camber)	BN1-BJ8	1
SR50	Splint	pin	BN1-BJ8	2
SR51	Splint	pin	BN1-BJ8	2
SR52	Splint	pin	BN1-BJ8	2
VA60AH	Fiber-Dichtscheibe 1/4"	fiber gasket 1/4"	BN1-BJ8	4
VA61AH	Keil	pin cotter	BN1-BJ8	2
VA62AH	Korkring	ring, cork	BN1-BJ8	4
VA63AH	Buchse Achsschenkel oben	bush, top	BN1-BJ8	2
VA64AH	Buchse Achsschenkel unten	bush, bottom	BN1-BJ8	2
VA65AH	Lagersatz für Schwenklager (Paar) - ersetzt die Einstellscheibe. Hierdurch wird ein deutlich verbessertes Lenken begünstigt	top trunnion bearing kit (pair) - replaces thrust washer. The steering is easier to handle.	BN1-BJ8	1
VA66AH	Buchse hinten	bush, rear	BN1-BJ8	2
VA67AH	Buchse vorne	bush, front	BN1-BJ8	2
VA68AH	Bolzen Achsschenkel unten	pin, fulcrum, lower link, outer	BN1-BJ8	2
VA80AH	Umbausatz für Koni-Stoßdämpfer vorne (einstellbar) * mit TÜV-Gutachten (Satz ohne Stoßdämpfer)	mounting kit Koni front shocker (adjustable) * - with TÜV-approval (shocker not included)	BN1-BJ8	1
VA80aMGB	Stoßdämpfer Koni zu VA80AH	shocker Koni to no. VA80AH	BN1-BJ8	2
VA2aAH	Reibahle Achsträger	reamer, king pin bush	BN1-BJ8	1
HSD	Hebelstoßdämpferöl, 0,5 Liter	shocker oil, 0.5 litre	BN1-BJ8	

* Anmerkung zu Art.Nr. VA80AH: Einfache Montage (unter Beibehalten und außer Kraft setzen der Originalstoßdämpfer) gemäß mitgelieferter Anleitung jederzeit möglich. Montageanleitungen auch im Internet.

* Note to no. VA80AH: Easily installed to every car, while the orig. shock absorbers are retained with their internal control valves removed. Kit complete with fitting instructions. Fitting instructions also available at www.bastuck.com



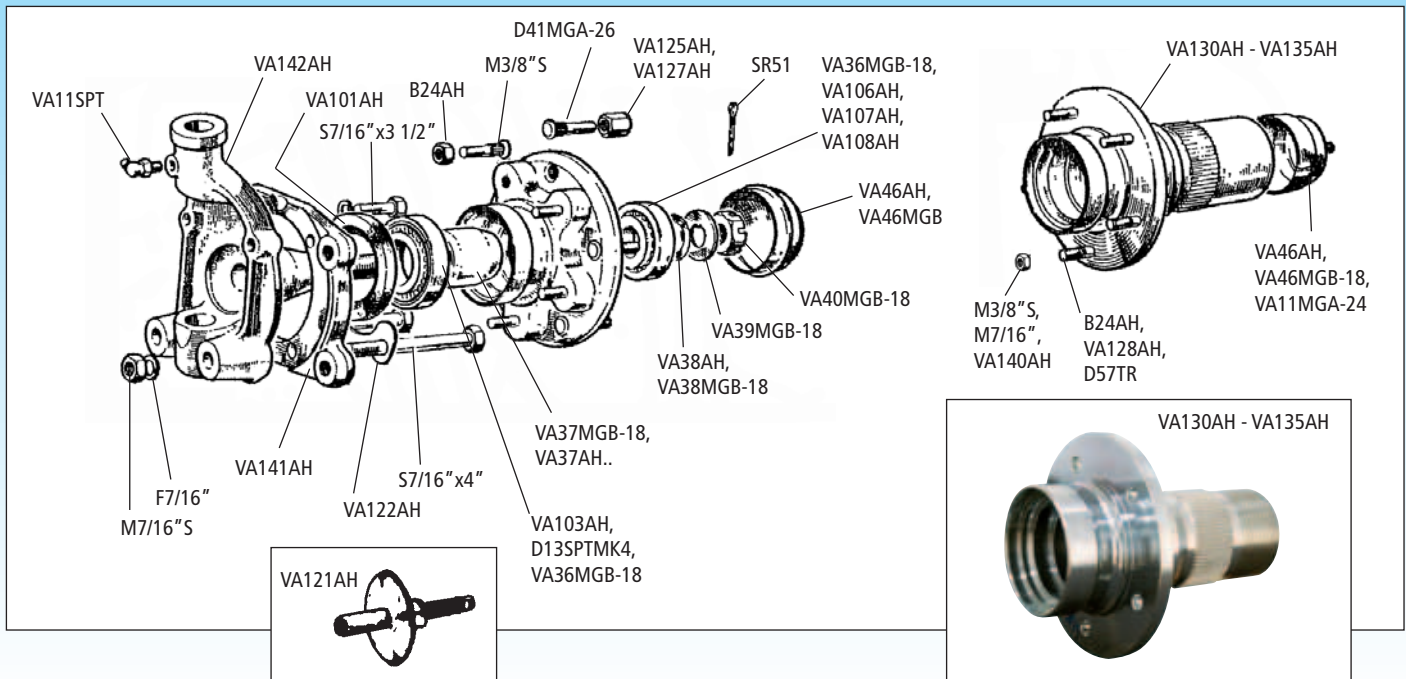

No.	Bezeichnung	Description	Type	Anzahl/Qty.
VA11MGA-24	Fettkappe (Stahlfelgen)	grease cap (steel wheels)	BN1-BJ8	2
VA11SPT	Schmiernippel	grease nipple	BN1<221404-BJ8	2
B24AH	Bolzen Bremsscheibe	bolt brake disc	BN7,BT7-BJ8<26704	10
VA39MGB-18	Sicherungsscheibe Radlager	bearing retaining washer	BN1-BJ8	2
VA40MGB-18	Kronenmutter	bearing retaining nut	BN1>221404-BJ8	2
D41MGA-26	Radbolzen Stahlfelge	wheel stud steel wheel	BN4, BN6	10
SR51	Splint	split pin	BN1-BJ8	2
VA101AH	Simmering Vorderachse	front hub seal	BN1-BJ8	2
VA122AH	Sicherungsblech	locktab	BN2,BN4,BN6,BN7,BT7,BJ7,BJ8<26704	2
VA125AH	Radbolzen Stahlfelge	wheel stud steel wheel	BN7, BT7, BJ7, BJ8	10
VA127AH	Radmutter Stahlfelge	wheel nut steel wheel	BN4-BJ8	10
VA140AH/BN1	Mutter Bolzen Bremstrommel	nut stud brake drum	BN1<228046	8
M7/16"	Mutter Bolzen Bremstrommel	nut stud brake drum	BN1>228047	8
VA141AH	Paar Halteplatten Bremssättel	plate adaptor	BN7, BT7, BJ7, BJ8	1
VA142AH	Paar (2) Achsträger	axle assembly, swivel	BN2>231203,BN4,BN6,BN7,BJ7<21766	2

Radlager BN1 / Wheel hub bearing BN1

VA103AH	Radlager innen	inner hub bearing	BN1	2
VA108AH	Radlager außen	outer hub bearing	BN1	2
VA37AH/BN1	Distanzstück Radlager vorne	distance piece, bearing front	BN1	2

Radlager BN2, BN4, BN6 mit Speichenfelgen / Wheel hub bearing BN2, BN4, BN6 with wire wheels

D13SPTMK4	Radlager innen	inner hub bearing	BN2, BN4, BN6	2
VA106AH	Radlager außen	outer hub bearing	BN2, BN4, BN6	2
VA37AH/BN7	Distanzstück Radlager vorne	distance piece, bearing front	BN2, BN4, BN6	2

Radlager BN4, BN6 mit Stahlfelgen / Wheel hub bearing BN4, BN6 with steel wheels

VA103AH	Radlager innen	inner hub bearing	BN4, BN6	2
VA107AH	Radlager außen	outer hub bearing	BN4, BN6	2
VA37AH/BN7	Distanzstück Radlager vorne	distance piece, bearing front	BN4, BN6	2

Radlager BN7, BT7, BJ7, BJ8<26704 / Wheel hub bearing BN7, BT7, BJ7, BJ8<26704

D13SPTMK4	Radlager innen	inner hub bearing	BN7,BT7,BJ7,BJ8<26704	2
VA106AH	Radlager außen	outer hub bearing	BN7,BT7,BJ7,BJ8<26704	2
VA37AH/BN7	Distanzstück Radlager vorne	distance piece, bearing front	BN7,BT7,BJ7,BJ8<26704	2

No.	Bezeichnung	Description	Type	Anzahl/Qty.
Radlager BJ8>26705 / Wheel hub bearing BJ8>26705 BJ8>26705 BJ8<26704 bearing				
VA36MGB-18	Radlagersatz (inneres und äußeres Lager)	set wheel hub bearing, inner and outer	BJ8>26705	2
VA37MGB-18	Distanzstück Radlager vorne	distance piece, bearing front	BJ8>26705	2
VA105AH	Radlager außen	outer hub bearing	BJ8>26705	2
Einstellscheiben Radlager / Shims wheel hub bearing - BN1, BN2, BN4, BN6, BN7, BT7, BJ8<26704				
VA38AH/.003	Ausgleichsscheibe 0.003" (0,08mm)	shim 0.003" (0,08 mm)	BN1,BN2,BN4,BN6,BN7,BT7,BJ8<26704	A/R
VA38AH/.005	Ausgleichsscheibe 0.005" (0,13 mm)	shim 0.005" (0,13 mm)	BN1,BN2,BN4,BN6,BN7,BT7,BJ8<26704	A/R
VA38AH/.010	Ausgleichsscheibe 0.010" (0,26 mm)	shim 0.010" (0,26 mm)	BN1,BN2,BN4,BN6,BN7,BT7,BJ8<26704	A/R
VA38AH/.032	Ausgleichsscheibe 0.032" (0,84 mm)	shim 0.032" (0,84 mm)	BN1,BN2,BN4,BN6,BN7,BT7,BJ8<26704	A/R
Einstellscheiben Radlager / Shims wheel hub bearing - BJ8>26705				
VA38MGB/.003	Ausgleichsscheibe 0.003" (0,08mm)	shim 0.003" (0,08mm)	BJ8>26705	A/R
VA38MGB/.005	Ausgleichsscheibe 0.005" (0,13 mm)	shim 0.005" (0,13 mm)	BJ8>26705	A/R
VA38MGB/.010	Ausgleichsscheibe 0.010" (0,26 mm)	shim 0.010" (0,26 mm)	BJ8>26705	A/R
VA38MGB/.030	Ausgleichsscheibe 0.030" (0,76 mm)	shim 0.030" (0,76 mm)	BJ8>26705	A/R
VA38MGB-18	Satz Ausgleichsscheiben	shim bearing, set	BJ8>26705	2
Fettkappen Radlager außen (Speichenfelgen) / Grease caps outer wheel bearing (wire wheels)				
VA46AH	für BN1, BN2,BN4,BN6,BN7,BJ7,BT7,BJ8>26704	for BN1,BN2,BN4,BN6,BN7,BJ7,BT7,BJ8<26704		2
VA46MGB-18	für BJ8<26705	for BJ8>26705		2
VA46aAH	für BN4,BN6	for BN4,BN6		2
VA11MGA-24	für BN7,BT7,BJ7,BJ8	for BN7,BT7,BJ7,BJ8		2
VA121AH	Abzieher für Fettkappe VA46AH/ VA46MGB-18 für Speichenfelge	extractor tool grease cap no. VA46AH/ VA46MGB-18 for wire wheels		1
Radnaben und Radbolzen (Speichenfelgen) / Wheel hubs and wheel studs (wire wheels) - BN1<228046				
VA135AH/L	Speichenradnabe vorne links	front wire wheel hub LH	BN1<228046	1
VA135AH/R	Speichenradnabe vorne rechts	front wire wheel hub RH	BN1<228046	1
VA128AH/BN1	Bolzen für Radnabe Nr. VA135AH zur Bremstrommel	stud, hub no. VA135AH to drum	BN1<228046	8
VA140AH/BN1	Mutter für Bolzen VA128AH/BN1	nut to stud VA128AH/BN1	BN1<228046	8
Radnaben und Radbolzen (Speichenfelgen) / Wheel hubs and wheel studs (wire wheels) - BN1>228047, BN2, BN4, BN6				
VA133AH/L	Speichenradnabe vorne links 12TPI Gewinde	front wire wheel hub LH - 12 tpi	BN2, BN4, BN6	1
VA133AH/R	Speichenradnabe vorne rechts 12TPI Gewinde	front wire wheel hub RH - 12 tpi	BN2, BN4, BN6	1
VA128AH/BN2	Bolzen für Radnabe Nr. VA133AH zur Bremstrommel	stud, hub no. VA133AH to drum	BN2, BN4, BN6	8
M7/16"	Mutter 7/16" für Bolzen VA128AH	nut 7/16" to stud VA128AH	BN2, BN4, BN6	8
Radnaben und Radbolzen (Speichenfelgen) / Wheel hubs and wheel studs (wire wheels) - BN7, BT7, BJ7, BJ8<26704				
VA131AH/L	Speichenradnabe vorne links 12TPI Gewinde	front wire wheel hub LH - 12 tpi	BN7,BT7,BJ7,BJ8<26704	1
VA131AH/R	Speichenradnabe vorne rechts 12TPI Gewinde	front wire wheel hub RH - 12 tpi	BN7,BT7,BJ7,BJ8<26704	1
M3/8"S	Selbstsichernde Mutter 7/16" für Bolzen B24AH	nut nyloc 7/16" to stud B24AH	BN7,BT7,BJ7,BJ8<26704	10
Radnaben und Radbolzen (Speichenfelgen) / Wheel hubs and wheel studs (wire wheels) - BJ8>26705				
VA130AH/L	Speichenradnabe vorne links 8TPI Gewinde	front wire wheel hub LH - 8 tpi	BJ8>26705	1
VA130AH/R	Speichenradnabe vorne rechts 8TPI Gewinde	front wire wheel hub RH - 8 tpi	BJ8>26705	1
D57TR	Bolzen für Radnabe Nr. VA130AH zur Brems- scheibe	stud, hub no. VA130AH to disk	BJ8>26705	10
M3/8"S	Selbstsichernde Mutter 3/8" für Bolzen D57TR	nut nyloc 3/8" to stud D57TR	BJ8>26705	10

Bitte beachten Sie, dass bei den Modellen 100/4 (BN1 bis Fgst.Nr. 221403) fast ausschließlich Schrauben und Muttern mit B.S.F. Gewinde verwendet wurden. Die angegebenen Schrauben und Muttern in der Illustration beziehen sich auf BN2-BJ8 Modelle mit UNF Gewinde! – B.S.F. Schrauben und Muttern finden Sie in der separaten Auflistung im Anhang S. 226-227.

Please note that on 100/4 models (BN1 up to chassis number 221403) the threads used have been almost exclusively B.S.F. The nuts and bolts referred to in the illustration are for the later BN2-BJ8 models with UNF thread!
- You will find details of the B.S.F. nuts and bolts in a separate list on page 226-227.

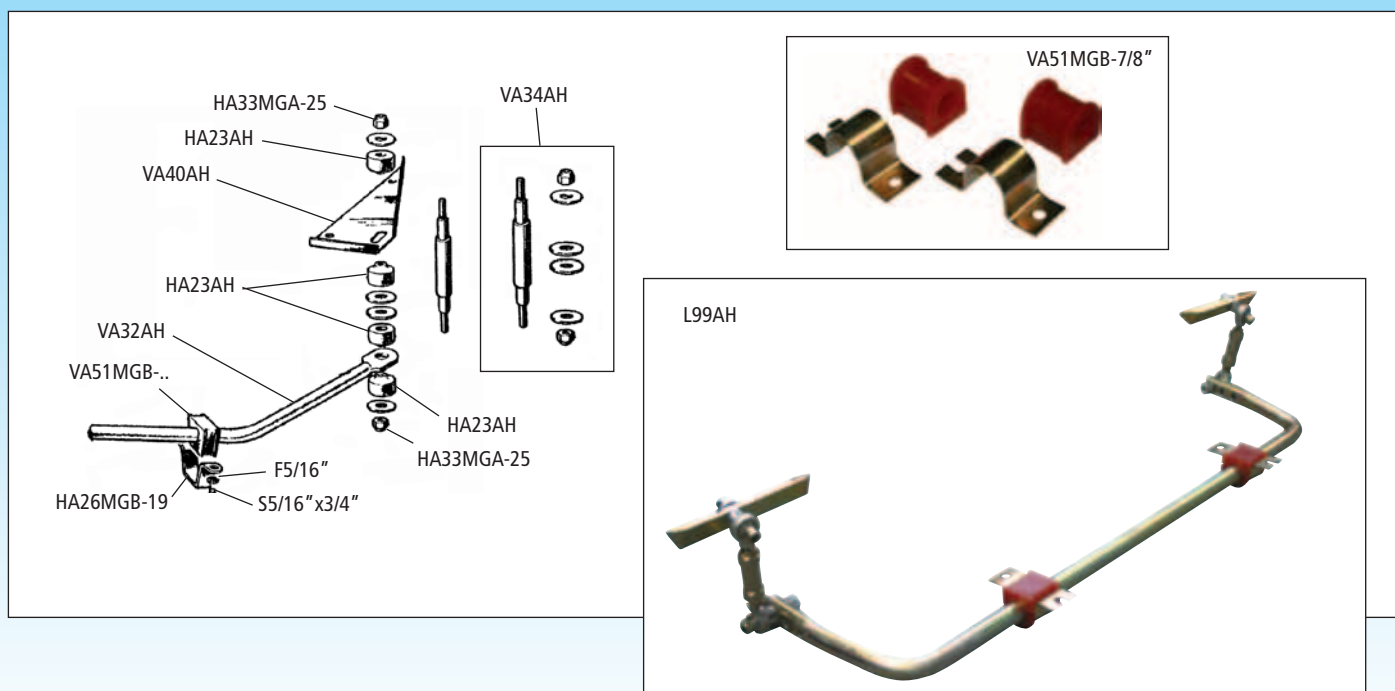

No.	Bezeichnung	Description	Type	Anzahl/Qty.
VA32AH	Stabilisator Ø 5/8" (Ø 16 mm)	anti-roll bar Ø 5/8" (Ø 16 mm)	BN4-BJ8	1
HA23AH	Gummi-Buchse	bush, link	BN1-BJ8	8
HA23AH/N	Nylotron-Buchse für Sportzwecke als Ersatz für HA23AH	Nylotron bush for competition use - replaces no. HA23AH	BN1-BJ8	
HA26MGB-19	Stabilisator Haltebügel	strap, bush	BN1-BJ8	2
HA33MGA-25	Mutter	nut	BN1-BJ8	8
VA34AH	Stabilisatorarm incl. Scheiben + Muttern (ohne Gummibuchsen)	link, anti-roll bar incl. washers + nuts (w/o bushes)		2
VA40AH/L	Halteplatte Stabilisator links	plate, anti-roll bar LH	BN1-BJ8	1
VA40AH/R	Halteplatte Stabilisator rechts	palte, anti-roll bar RH	BN1-BJ8	1
VA51MGB-9/16"	Haltegummi für 9/16" Stabilisator	bush, rubber to fit 9/16" anti-roll bar	BN1-BN2	2
VA51MGB-5/8"	Haltegummi für 5/8" Stabilisator	bush, rubber to fit 5/8" anti-roll bar	BN4-BJ8	2
VA51MGB-3/4"	Haltegummi für 3/4" Stabilisator	bush, rubber to fit 3/4" anti-roll bar	BN1-BJ8	2
	Neopren Lagersätze - als Ersatz der oben aufgeführten Haltegummis VA51MGB-...:	Neopren bush mountings - to replace the rubber bushes no. VA51MGB-... listed above:		
VA51MGB-5/8"N	Paar Neopren Lager für 5/8" Stabilisator	neopren bush mountings to 5/8" anti-roll bar	BN4-BJ8	1
VA51MGB-3/4"N	Paar Neopren Lager für 3/4" Stabilisator	neopren bush mountings to 3/4" anti-roll bar	BN1-BJ8	1
VA51MGB-7/8"	Paar Neopren Lager für 7/8" Stabilisator	neopren bush mountings to 7/8" anti-roll bar	BN1-BJ8	1
L99AH	Stabilisator-Kit Ø 7/8" (Ø 22 mm) verstärkt, einstellbar für Motorsport und Straße, mit Uniball-Gelenken - Montageanleitung auf der Internetseite	anti-roll bar set Ø 7/8" (Ø 22 mm), reinforced, adjustable for road and race use, with reset joints - mounting instruction on our website	BN1-BJ8	1

Bitte beachten Sie, dass bei den Modellen 100/4 (BN1 bis Fgst.Nr. 221403) fast ausschließlich Schrauben und Muttern mit B.S.F. Gewinde verwendet wurden. Die angegebenen Schrauben und Muttern in der Illustration beziehen sich auf BN2-BJ8 Modelle mit UNF Gewinde! – B.S.F. Schrauben und Muttern finden Sie in der separaten Auflistung im Anhang S. 226-227.

Please note that on 100/4 models (BN1 up to chassis number 221403) the threads used have been almost exclusively B.S.F. The nuts and bolts referred to in the illustration are for the later BN2-BJ8 models with UNF thread!
- You will find details of the B.S.F nuts and bolts in a separate list on page 226-227.

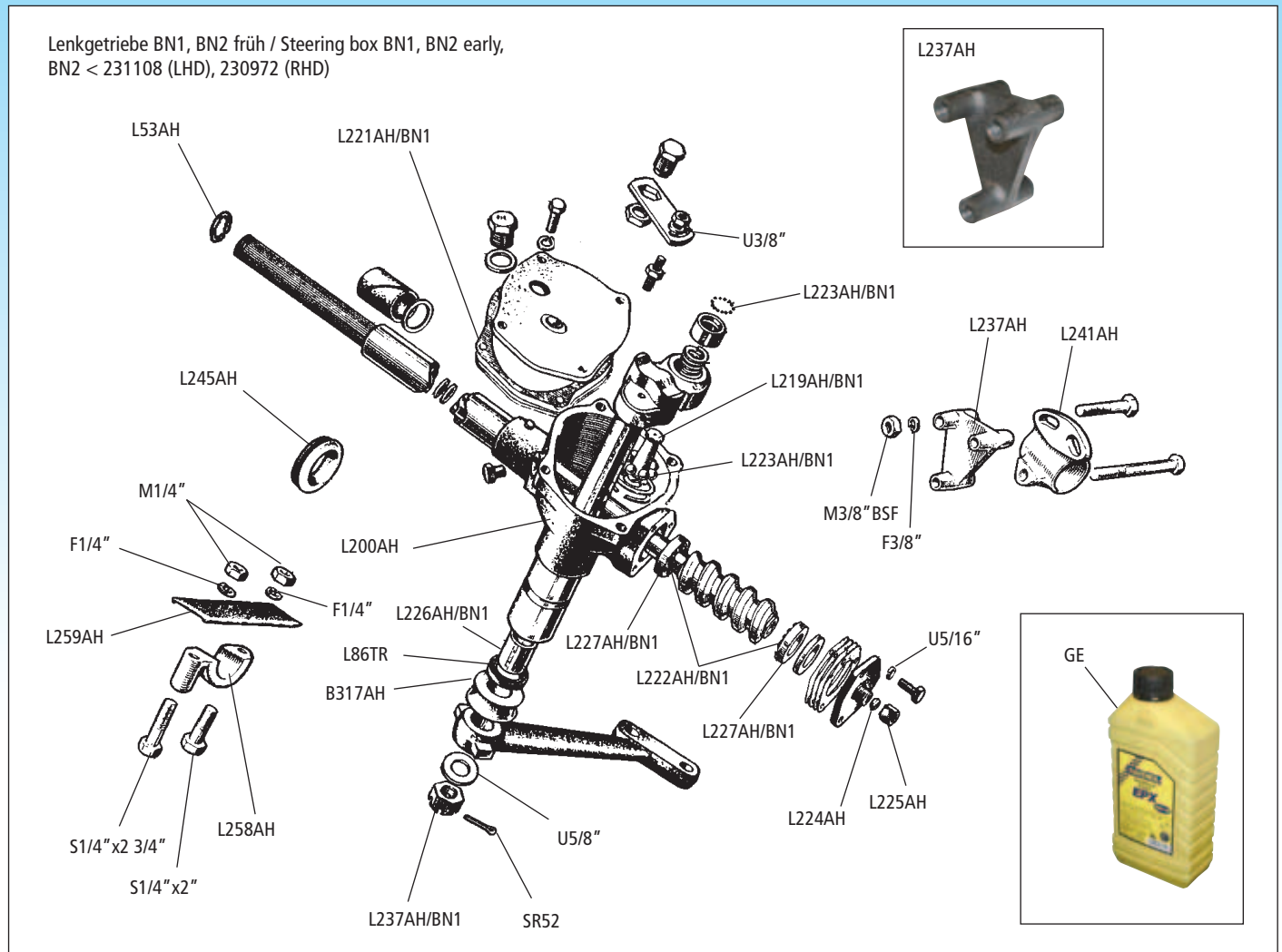

Lenkgetriebe / Steering box BN1, BN2 früh/early, BN2 < 231108 (LHD), 230972 (RHD)

No.	Bezeichnung	Description	Type	Anzahl/ Qty.
L53AH	Federring (verstellbare Lenksäule)	circlip (adjustable steering)	BN2<231108 (LHD), 230972 (RHD)	1
L86TR	Simmering	oil seal	BN2<231108 (LHD), 230972 (RHD)	1
L200AH/BN1	Lenkgetriebe Lenkslenker (nicht verstellbare Lenksäule)	steering box LHD (non adjustable steering)	BN2<231108 (LHD), 230972 (RHD)	1
L200AH/BN1RHD	Lenkgetriebe Lenkslenker (nicht verstellbare Lenksäule)	steering box LHD (non adjustable steering)	BN2<231108 (LHD), 230972 (RHD)	1
L219AH/BN1	Lenkfinger	peg, for rocker shaft	BN2<231108 (LHD), 230972 (RHD)	1
L221AH/BN1	Dichtung Lenkgetriebe .010"	gasket, top cover .010"	BN2<231108 (LHD), 230972 (RHD)	1
L222AH/BN1	Lagersatz Lenkschnecke	ball, bearing set	BN2<231108 (LHD), 230972 (RHD)	1
L223AH/BN1	Lager Lenkung	ball, bearing set, steering peg	BN2<231108 (LHD), 230972 (RHD)	1
L224AH	Schneidring	olive steering end	BN2<231108 (LHD), 230972 (RHD)	1
L225AH	Mutter Lenksäule unten	nut steering end	BN2<231108 (LHD), 230972 (RHD)	1
L226AH/BN1	Lagerbuchse Lenkfinger	bush, steering box	BN2<231108 (LHD), 230972 (RHD)	1
L227AH/BN1	Lagerschale Lenkspindel	cup, ball cage	BN2<231108 (LHD), 230972 (RHD)	2
L237AH	Abstandshalter Lenksäule	spacer bracket	BN2<231108 (LHD), 230972 (RHD)	1
L237AH/BN1	Kronenmutter 5/8"	nut, slotted 5/8"	BN2<231108 (LHD), 230972 (RHD)	1
L241AH	Halteklammer Lenkgetriebe	clamp, bracket steering box	BN2<231108 (LHD), 230972 (RHD)	1
L245AH	Gummi Durchführung Lenksäule	grommet, steering column (pair)	BN2<231108 (LHD), 230972 (RHD)	1
L258AH	Paar Halteklammern Lenkrohr	clamp, steering column (pair)	BN2<231108 (LHD), 230972 (RHD)	1
L259AH	Gummistreifen Lenkrohr	rubber strip	BN2<231108 (LHD), 230972 (RHD)	1
B317AH	Filz Staubschutz	dust cover	BN2<231108 (LHD), 230972 (RHD)	1
GE	Hypoid Getriebeöl 80/W90, pro Liter	Hypoid gear oil oil 80/W90 per liter	BN2<231108 (LHD), 230972 (RHD)	A/R

Lenkgetriebe / Steering BN2 > 231109 (LHD), 230978 (RHD), BN4 < 68959, BN6 < 1994

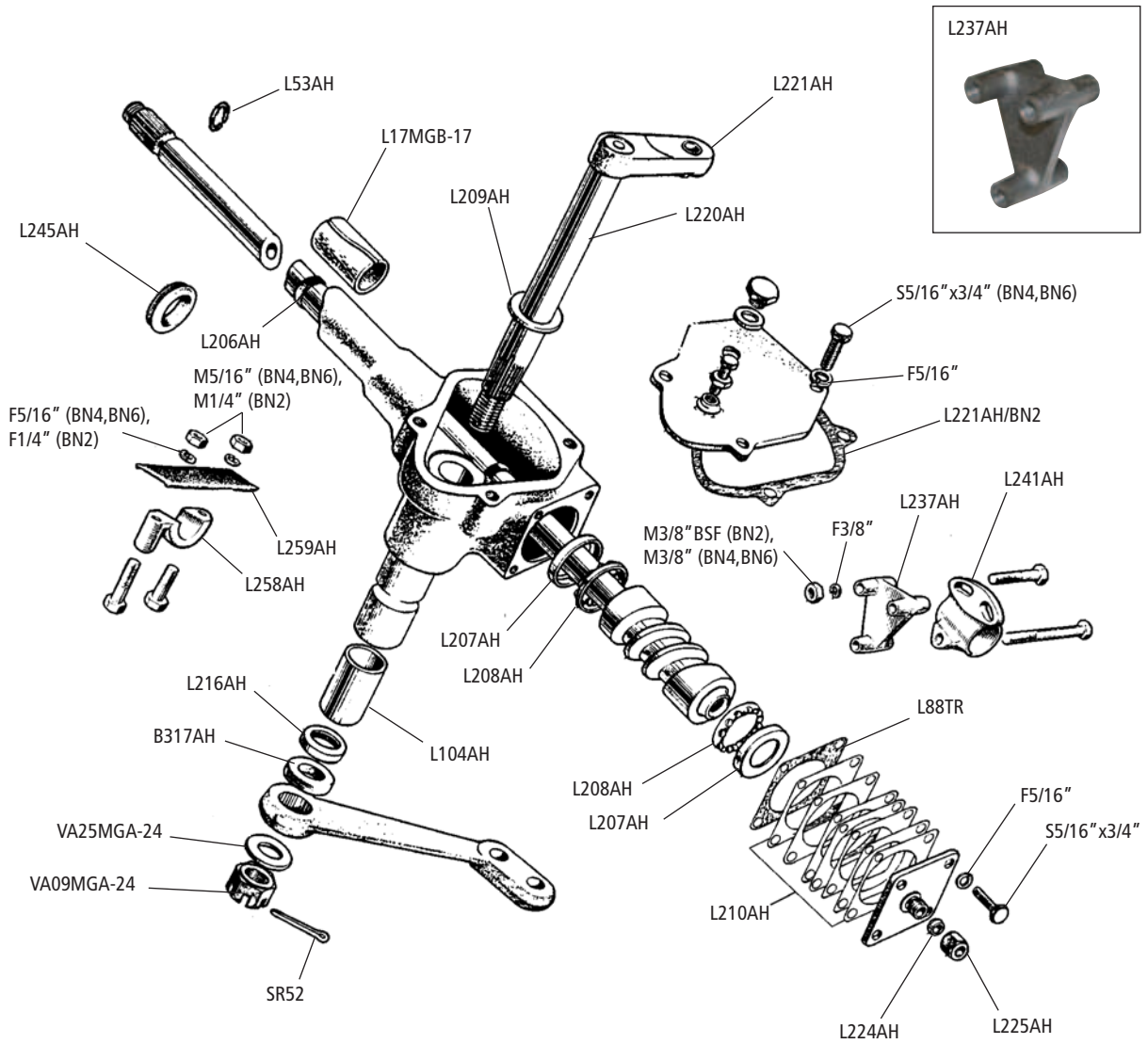

Lenkgetriebe / Steering BN2 > 231109 (LHD), 230978 (RHD), BN4 < 68959, BN6 < 1994

No.	Bezeichnung	Description	Type	Anzahl/Qty.
L200AH/BN4	Lenkgetriebe Linkslenker (verstellbare Lenksäule)	steering box assembly LHD (adjustable steering)	BN4	1
L200AH/BN4RHD	Lenkgetriebe Rechtslenker (verstellbare Lenksäule)	steering box assembly RHD (adjustable steering)	BN4	1
L200AH/BN6	Lenkgetriebe Linkslenker (nicht verstellbare Lenksäule)	steering box assembly LHD (non adjustable steering)	BN2, BN6	1
L200AH/BN6RHD	Lenkgetriebe Rechtslenker (nicht verstellbare Lenksäule)	steering box assembly RHD (non adjustable steering)	BN2, BN6	1
VA09MGA-24	Kronenmutter 3/4" UNF	nut, slotted 3/4" UNF	BN2>231109(LHD), 230978(RHD), BN4<68959, BN6<1994	1
L17MGB-17	Lagerbuchse (Filz)	bush, felt	BN2>231109(LHD), 230978(RHD), BN4<68959, BN6<1994	1
VA25MGA-24	Unterlagscheibe	washer, plain	BN2>231109(LHD), 230978(RHD), BN4<68959, BN6<1994	1
SR52	Splint	cotter pin	BN2>231109(LHD), 230978(RHD), BN4<68959, BN6<1994	1
L53AH	Sicherungsring verstellbare Lenksäule	circlip adjustable column	BN2>231109(LHD), 230978(RHD), BN4<68959, BN6<1994	1
L88TR	Dichtung Lenkgetriebe	gasket end cover	BN2>231109(LHD), 230978(RHD), BN4<68959, BN6<1994	1
L104AH	Lagerbuchse	bush	BN2>231109(LHD), 230978(RHD), BN4<68959, BN6<1994	1
L206AH	Gummiring	rubber ring	BN2>231109(LHD), 230978(RHD), BN4<68959, BN6<1994	2
L207AH	Lagerschale Lenkspindel	cup ball cage	BN2>231109(LHD), 230978(RHD), BN4<68959, BN6<1994	2
L208AH	Kugellager	cage, ball assembly	BN2>231109(LHD), 230978(RHD), BN4<68959, BN6<1994	2
L209AH	Scheibe	washer	BN2>231109(LHD), 230978(RHD), BN4<68959, BN6<1994	6
L210AH/002	Ausgleichsscheibe Lenkung 0.002"-0.0024"	shim 0.002"-0.0024"	BN2>231109(LHD), 230978(RHD), BN4<68959, BN6<1994	A/R
L210AH/005	Ausgleichsscheibe Lenkung 0.005"	shim 0.005"	BN2>231109(LHD), 230978(RHD), BN4<68959, BN6<1994	A/R
L210AH/010	Ausgleichsscheibe Lenkung 0.010"	shim 0.010"	BN2>231109(LHD), 230978(RHD), BN4<68959, BN6<1994	A/R
L216AH	Simmerring Lenkgetriebe	oil seal	BN2>231109(LHD), 230978(RHD), BN4<68959, BN6<1994	1
L220AH	Lenkfinger	rock shaft	BN2>231109(LHD), 230978(RHD), BN4<68959, BN6<1994	1
L221AH	Gleitlager Lenkfinger	peg, rock shaft	BN2>231109(LHD), 230978(RHD), BN4<68959, BN6<1994	1
L221AH/BN2	Dichtung Lenkgetriebe	gasket	BN2>231109(LHD), 230978(RHD), BN4<68959, BN6<1994	1
L224AH	Schneidring	olive, steering end	BN2>231109(LHD), 230978(RHD), BN4<68959, BN6<1994	1
L225AH	Mutter Lenksäule unten	nut, steering end	BN2>231109(LHD), 230978(RHD), BN4<68959, BN6<1994	1
L237AH	Abstandshalter Lenksäule	spacer bracket	BN2>231109(LHD), 230978(RHD), BN4<68959, BN6<1994	1
L241AH	Halteklammer Lenkgetriebe	clamp bracket, steering box	BN2>231109(LHD), 230978(RHD), BN4<68959, BN6<1994	1
L245AH	Gummidurchführung Lenksäule	grommet, steering column/ bulkhead	BN2>231109(LHD), 230978(RHD), BN4<68959, BN6<1994	1
L258AH	Paar Halteklammern Lenkrohr	clamp, steering column (pair)	BN2>231109(LHD), 230978(RHD), BN4<68959, BN6<1994	1
L259AH	Gummistreifen Lenkrohr	rubber strip	BN2>231109(LHD), 230978(RHD), BN4<68959, BN6<1994	1
B317AH	Filz-Staubschutz	dust cover	BN2>231109(LHD), 230978(RHD), BN4<68959, BN6<1994	1
GE	Hypoid Getriebeöl 80/W90, pro Liter	Hypoid gear oil oil 80/W90 per liter	BN2>231109(LHD), 230978(RHD), BN4<68959, BN6<1994	A/R

Lenkgetriebe / Steering box BN4 > 68960, BN6 > 1995, BN7, BT7, BJ7, BJ8

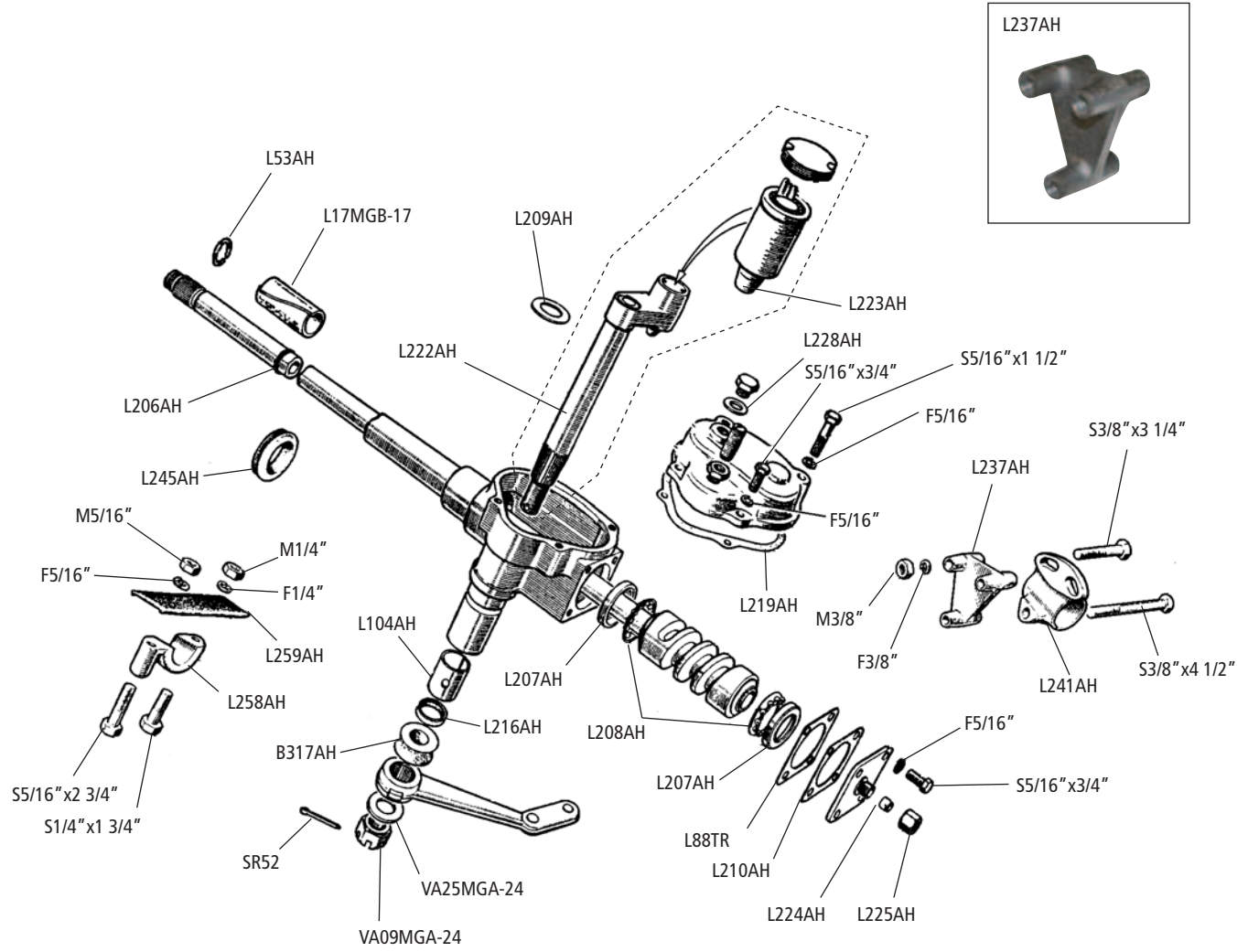

Lenkgetriebe / Steering box BN4 > 68960, BN6 >1995, BN7, BT7, BJ7, BJ8

No.	Bezeichnung	Description	Type	Anzahl/Qty.
L200AH	Lenkgetriebe Linkslenker (nicht verstellbare Lenksäule)	steering box assembly LHD (non adjustable steering)	BN4>68960,BN6>1995,BN7,BT7,BJ7,BJ8	1
L200AHRHD	Lenkgetriebe Rechtslenker (nicht verstellbare Lenksäule)	steering box assembly RHD (adjustable steering)	BN4>68960,BN6>1995,BN7,BT7,BJ7,BJ8	1
L200AH/ADJ	Lenkgetriebe Linkslenker (verstellbare Lenksäule)	steering box assembly LHD (adjustable steering)	BN4>68960,BN6>1995,BN7,BT7,BJ7,BJ8	1
L200AH/ADJRHD	Lenkgetriebe Rechtslenker (verstellbare Lenksäule)	steering box assembly RHD (adjustable steering)	BN4>68960,BN6>1995,BN7,BT7,BJ7,BJ8	1
VA09MGA-24	Kronenmutter 3/4" UNF	nut, slotted 3/4" UNF	BN4>68960,BN6>1995,BN7,BT7,BJ7,BJ8	1
L17MGB-17	Lagerbuchse (Filz)	bush, felt	BN4>68960,BN6>1995,BN7,BT7,BJ7,BJ8	1
VA25MGA-24	Unterlagscheibe	washer, plain	BN4>68960,BN6>1995,BN7,BT7,BJ7,BJ8	1
SR52	Splint	cotter pin	BN4>68960,BN6>1995,BN7,BT7,BJ7,BJ8	1
L53AH	Sicherungsring verstellbare Lenksäule	circlip adjustable column	BN4>68960,BN6>1995,BN7,BT7,BJ7,BJ8	1
L88TR	Dichtung Lenkgetriebe	gasket end cover	BN4>68960,BN6>1995,BN7,BT7,BJ7,BJ8	1
L104AH	Lagerbuchse	bush	BN4>68960,BN6>1995,BN7,BT7,BJ7,BJ8	1
L206AH	Gummiring	rubber ring	BN4>68960,BN6>1995,BN7,BT7,BJ7,BJ8	2
L207AH	Lagerschale Lenkspindel	cup ball cage	BN4>68960,BN6>1995,BN7,BT7,BJ7,BJ8	2
L208AH	Kugellager	cage, ball assembly	BN4>68960,BN6>1995,BN7,BT7,BJ7,BJ8	2
L209AH	Scheibe	washer	BN4>68960,BN6>1995,BN7,BT7,BJ7,BJ8	6
L210AH/002	Ausgleichsscheibe Lenkung 0.002" -0.0024"	shim 0.002" -0.0024"	BN4>68960,BN6>1995,BN7,BT7,BJ7,BJ8	A/R
L210AH/005	Ausgleichsscheibe Lenkung 0.005"	shim 0.005"	BN4>68960,BN6>1995,BN7,BT7,BJ7,BJ8	A/R
L210AH/010	Ausgleichsscheibe Lenkung 0.010"	shim 0.010"	BN4>68960,BN6>1995,BN7,BT7,BJ7,BJ8	A/R
L216AH	Simmerring Lenkgetriebe	oil seal	BN4>68960,BN6>1995,BN7,BT7,BJ7,BJ8	1
L219AH	Dichtung	gasket	BN4>68960,BN6>1995,BN7,BT7,BJ7,BJ8	1
L222AH	Lenkfinger	rocker shaft assembly	BN4>68960,BN6>1995,BN7,BT7,BJ7,BJ8	1
L223AH	Gleitlager Lenkfinger	peg, rocker shaft	BN4>68960,BN6>1995,BN7,BT7,BJ7,BJ8	1
L224AH	Schneidring	olive, steering end	BN4>68960,BN6>1995,BN7,BT7,BJ7,BJ8	1
L225AH	Mutter Lenksäule unten	nut, steering end	BN4>68960,BN6>1995,BN7,BT7,BJ7,BJ8	1
L228AH	Fiberscheibe	washer, fibre	BN4>68960,BN6>1995,BN7,BT7,BJ7,BJ8	1
L237AH	Abstandshalter Lenksäule	spacer bracket	BN4>68960,BN6>1995,BN7,BT7,BJ7,BJ8	1
L241AH	Halteklammer Lenkgetriebe	clamp bracket, steering box	BN4>68960,BN6>1995,BN7,BT7,BJ7,BJ8	1
L245AH	Gummidurchführung Lenksäule	grommet, steering column/bulkhead	BN4>68960,BN6>1995,BN7,BT7,BJ7,BJ8	1
L258AH	Paar Halteklammern Lenkrohr	clamp, steering column (pair)	BN4>68960,BN6>1995,BN7,BT7,BJ7,BJ8	1
L259AH	Gummistreifen Lenkrohr	rubber strip	BN4>68960,BN6>1995,BN7,BT7,BJ7,BJ8	1
B317AH	Filz-Staubschutz	dust cover	BN4>68960,BN6>1995,BN7,BT7,BJ7,BJ8	1
GE	Hypoid Getriebeöl 80/W90, pro Liter	Hypoid gear oil oil 80/W90 per liter	BN4>68960,BN6>1995,BN7,BT7,BJ7,BJ8	A/R

Spurstangen, Spurstangenendköpfe / Centre rods, track rod ends
BN1-BN7



Spurstangen, Spurstangenendköpfe / Centre rods, track rod ends
BJ7-BJ8



Spurstangen außen / Side rods,
BN1-BJ8



Umlenkung Lenkung, Spurstangen / Steering Idlers, centre/side rods

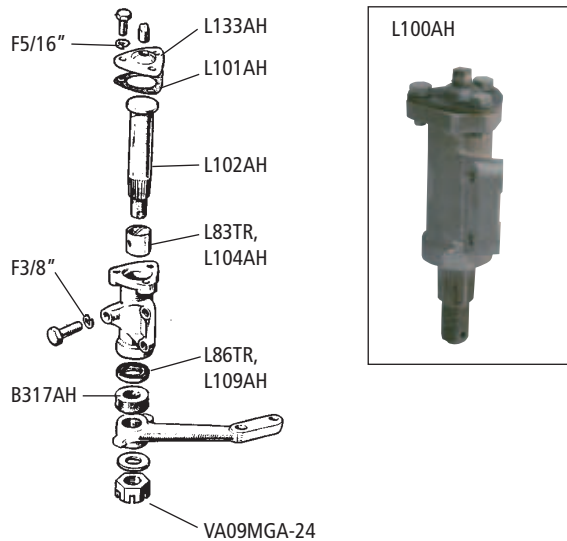

Spurstangen, Spurstangenendköpfe / Centre rods, track rod ends

No.	Bezeichnung	Description	Type	Anzahl/Qty.
L28AH	Spurstange außen	side rod	BN1-BJ8	2
L30AH/BN1	Paar Spurstangenendköpfe innen	pair track rod ends center	BN1-BN2<228931	1
L30AH/BN2	Paar Spurstangenendköpfe innen	pair track rod ends center	BN2>228932, BN4, BN6, BN7,BT7/BJ7<19190	1
L30AH/BJ7	Paar Spurstangenendköpfe innen	pair track rod ends center	BT7/BJ7>19191, BJ8	1
L31AH/BN1L	Kontermutter Spurstangenendkopf Linksgewinde	locknut left hand thread	BN1-BN2<228931	1
L31AH/BN1R	Kontermutter Spurstangenendkopf Rechtsgewinde	locknut right hand thread	BN1-BN2<228931	1
L32AH/BN1	mittlere Spurstange	centre rod	BN1-BN2<228931	1
L32AH/BN2	mittlere Spurstange	centre rod	BN2>228932, BN4, BN6, BN7,BT7/BJ7<19190	1
L32AH/BJ7	mittlere Spurstange	centre rod	BT7/BJ7>19191, BJ8	1
L82TR	Kontermutter Spurstangenendkopf Rechtsgewinde	locknut right hand thread	BN2>228932, BN4, BN6, BN7,BT7/BJ7<19190	1
L82aTR	Kontermutter Spurstangenendkopf Linksgewinde	locknut left hand thread	BN2>228932, BN4, BN6, BN7,BT7/BJ7<19190	1
HM5/8"	Kontermutter Spurstangenendkopf Rechtsgewinde	locknut right hand thread	BT7/BJ7>19191, BJ8	1
HM5/8"L	Kontermutter Spurstangenendkopf Linksgewinde	locknut left hand thread	BT7/BJ7>19191, BJ8	1

Umlenkung Lenkung, Spurstangen / Steering idler assemblies, centre/side rods

BN1, BN2 < 231108 (LHD), 230977 (RHD)

No.	Bezeichnung	Description	Type	Anzahl/Qty.
L83TR	Lagerbuchse	bush	BN1,BN2<231108(LHD), 230977(RHD)	2
L86TR	Simmerring	oil seal	BN1,BN2<231108(LHD), 230977(RHD)	1
L100AH/BN1L	Umlenkung Lenkung Linkslenker, komplett	steering idler LHD	BN1,BN2<231108(LHD), 230977(RHD)	1
L100AH/BN1R	Umlenkung Lenkung Rechtslenker, komplett	steering idler RHD	BN1,BN2<231108(LHD), 230977(RHD)	1
L101AH	Dichtung	gasket cover	BN1,BN2<231108(LHD), 230977(RHD)	1
L102AH/BN1	Welle in Umlenkung	shaft idler	BN1,BN2<231108(LHD), 230977(RHD)	1
B317AH	Filz Staubschutz	dust cover	BN1,BN2<231108(LHD), 230977(RHD)	1

Umlenkung Lenkung, Spurstangen / Steering idler assemblies, centre/side rods

BN2 > 231109 (LHD), 230978 (RHD), BN4, BN6, BN7, BT7, BJ7, BJ8

No.	Bezeichnung	Description	Type	Anzahl/Qty.
VA09MGA-24	Kronenmutter	nut, idle shaft	BN2>231109(LHD), 230978(RHD),BN4,BN6,BN7,BT7,BJ7,BJ8	1
VA25MGA-24	Unterlagscheibe	washer	BN2>231109(LHD), 230978(RHD),BN4,BN6,BN7,BT7,BJ7,BJ8	1
L100AHL	Umlenkung Lenkung Linkslenker, komplett	steering idler LHD	BN2>231109(LHD), 230978(RHD),BN4,BN6,BN7,BT7,BJ7,BJ8	1
L100AHR	Umlenkung Lenkung Rechtslenker, komplett	steering idler RHD	BN2>231109(LHD), 230978(RHD),BN4,BN6,BN7,BT7,BJ7,BJ8	1
L101AH	Dichtung	gasket cover	BN2>231109(LHD), 230978(RHD),BN4,BN6,BN7,BT7,BJ7,BJ8	1
L102AH	Welle in Umlenkung Lenkung	shaft idler	BN2>231109(LHD), 230978(RHD),BN4,BN6,BN7,BT7,BJ7,BJ8	1
L104AH	Lagerbuchse	bush	BN2>231109(LHD), 230978(RHD),BN4,BN6,BN7,BT7,BJ7,BJ8	2
L109AH	Simmerring	oil seal	BN2>231109(LHD), 230978(RHD),BN4,BN6,BN7,BT7,BJ7,BJ8	1
L133AH	Deckel	cover	BN2>231109(LHD), 230978(RHD),BN4,BN6,BN7,BT7,BJ7,BJ8	1
B317AH	Filz Staubschutz	dust cover	BN2>231109(LHD), 230978(RHD),BN4,BN6,BN7,BT7,BJ7,BJ8	1



Beispiel: Lenkrad Holz - gelocht
 Example: Steering wheel, wood - drilled



Beispiel: Lenkrad Leder - gelocht
 Example: Steering wheel, leather - drilled



Beispiel: Lenkrad Vollholz - gerautet, ohne Nieten
 Example: Steering wheel, wood - sloted, without rivets



Beispiel: Lenkrad Holz - 4 Speichen
 Example: Steering wheel, wood - 4 spokes

Schema: Lenkrad flach
 Sheme: steering wheel plain

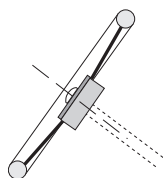

Schema: Lenkrad geschüsselt
 Sheme: steering wheel bowl form

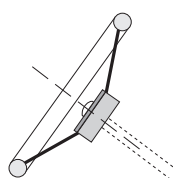

Sportlenkräder ohne ABE / Sport steering wheels w/o homologation

No.	Bezeichnung	Description
L100TR	Lenkrad 13" Leder - gelocht, geschüsselt	Steering wheel 13" leather - drilled, bowl form
L101TR	Lenkrad 13" Leder - gelocht, flach	Steering wheel 13" leather - drilled, plain
L102TR	Lenkrad 13" Leder - gerautet, geschüsselt	Steering wheel 13" leather - sloted, bowl form
L103TR	Lenkrad 13" Leder - gerautet, flach	Steering wheel 13" leather - sloted, plain
L110TR	Lenkrad 14" Leder - gelocht, geschüsselt	Steering wheel 14" leather - drilled, bowl form
L111TR	Lenkrad 14" Leder - gelocht, flach	Steering wheel 14" leather - drilled, plain
L112TR	Lenkrad 14" Leder - gerautet, geschüsselt	Steering wheel 14" leather - sloted, bowl form
L113TR	Lenkrad 14" Leder - gerautet, flach	Steering wheel 14" leather - sloted, plain
L120TR	Lenkrad 15" Leder - gelocht, geschüsselt	Steering wheel 15" leather - drilled, bowl form
L121TR	Lenkrad 15" Leder - gelocht, flach	Steering wheel 15" leather - drilled, plain
L122TR	Lenkrad 15" Leder - gerautet, geschüsselt	Steering wheel 15" leather - sloted, bowl form
L123TR	Lenkrad 15" Leder - gerautet, flach	Steering wheel 15" leather - sloted, plain
L130TR	Lenkrad 13" Holz - gelocht, geschüsselt	Steering wheel 13" wood - drilled, bowl form
L131TR	Lenkrad 13" Holz - gelocht, flach	Steering wheel 13" wood - drilled, plain
L132TR	Lenkrad 13" Holz - gerautet, geschüsselt	Steering wheel 13" wood - sloted, bowl form
L133TR	Lenkrad 13" Holz - gerautet, flach	Steering wheel 13" wood - sloted, plain
L140TR	Lenkrad 14" Holz - gelocht, geschüsselt	Steering wheel 14" wood - drilled, bowl form
L141TR	Lenkrad 14" Holz - gelocht, flach	Steering wheel 14" wood - drilled, plain
L142TR	Lenkrad 14" Holz - gerautet, geschüsselt	Steering wheel 14" wood - sloted, bowl form
L143TR	Lenkrad 14" Holz - gerautet, flach	Steering wheel 14" wood - sloted, plain
L150TR	Lenkrad 15" Holz - gelocht, geschüsselt	Steering wheel 15" wood - drilled, bowl form
L151TR	Lenkrad 15" Holz - gelocht, flach	Steering wheel 15" wood - drilled, plain
L152TR	Lenkrad 15" Holz - gerautet, geschüsselt	Steering wheel 15" wood - sloted, bowl form
L153TR	Lenkrad 15" Holz - gerautet, flach	Steering wheel 15" wood - sloted, plain
L160TR	Lenkrad 14" Vollholz - ohne Nieten, gerautet, geschüsselt	Steering wheel 14" wood - w/o rivets, sloted, bowl form
L163TR	Lenkrad 14" Vollholz - ohne Nieten, gelocht, geschüsselt	Steering wheel 14" wood - w/o rivets, drilled, bowl form
L170TR	Lenkrad 15" Holz - mit Nieten, 4 Speichen, flach	Steering wheel 15" wood - riveted, 4 spokes, plain
L80AH	Adapter für Sportlenkrad nicht verstellbare Lenksäule, BN1-BJ8 (auch passend für Moto-Lita Lenkrad)	Adaptor for sport steering wheel, BN1-BJ8 non-adjustable steering control head (also suitable for Moto-Lita steering wheels)
L80bTR	Adapter für Sportlenkrad verstellbare Lenksäule, BN1-BJ8 (auch passend für Moto-Lita Lenkrad)	Adaptor for sport steering wheel, BN1-BJ8 adjustable steering control head (also suitable for Moto-Lita steering wheels)

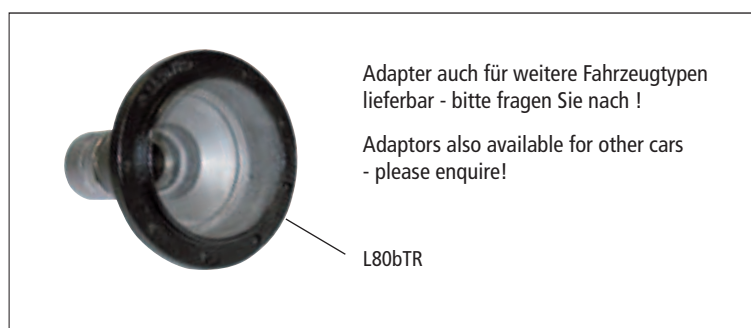

Speichenräder / Wire wheels

- lackiert und chrom
- painted and chrome finish



F6TR 4 1/2 x 15"



F7TR 4 1/2 x 15"



F8TR 5 1/2 x 15"



F9TR 5 1/2 x 15"



F10TR 5 1/2 x 15"



Minilite Style



F50AH



F54TR 5 1/2 x 15"

F13SPT,
F22MGA-36,
F23MGA-36



F12SPT,
F18MGA-36,
F19MGA-36



F14SPT,
F24MGA-36,
F25MGA-36



F15AH



F16AH

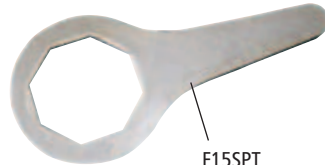

F15SPT

F19SPT



F16SPT

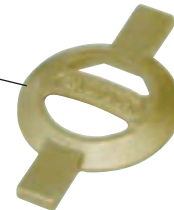

F51TR



F30SPT



F17SPT

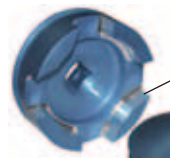

F18SPT



No.	Bezeichnung	Description	Type	Anzahl/Qty.
Speichenfelgen chrom		Wire wheels chrome finish		
F6TR	Speichenfelge Chrom 4 1/2 x 15", 60 Speichen	wire wheel chrome 4 1/2 x 15", 60 spokes	BN1-BJ8	4
F8TR	Speichenfelge Chrom 5 1/2 x 15", 72 Speichen	wire wheel chrome 5 1/2 x 15", 72 spokes	BN1-BJ8	4
F10TR	Speichenfelge Chrom 5 1/2 x 15", 70 Speichen Tiefbett	wire wheel chrome 5 1/2 x 15", 70 spoke well-base rim	BN1-BJ8	4
F12MGA-36	Speichenfelge Chrom 4 x 15", 48 Speichen	wire wheel chrome 4 x 15", 48 spokes	BN1-BJ8	4
Speichenfelgen lackiert		Wire wheels painted finish		
F7TR	Speichenfelge lackiert 4 1/2 x 15", 60 Speichen	wire wheel painted 4 1/2 x 15", 60 spokes	BN1-BJ8	4
F7aTR	Speichenfelge lackiert 4 1/2" x 15", 72 Speichen, Competition	wire wheel painted 4 1/2 x 15", 72 spokes Competition	BN1-BJ8	4
F9TR	Speichenfelge lackiert 5 1/2 x 15", 72 Speichen	wire wheel painted 5 1/2 x 15", 72 spokes	BN1-BJ8	4
F13MGA-36	Speichenfelge lackiert 4 x 15", 48 Speichen	wire wheel painted 4 x 15", 48 spokes	BN1-BJ8	4
F1AH	Radkappen Stahlfelge	chrome hub cap disc wheel	BN4-BJ8	4
F15AH	Speichenfelge Reinigungsbürste	wire wheel cleaning brush	BN1-BJ8	1
F15SPT	Speichenradschlüssel 8-Kant Stahl	octagon wheel nut spanner	BN1-BJ8	1
F16SPT	Speichenradschlüssel 8-Kant Messing	octagon wheel nut spanner brass	BN1-BJ8	1
F16AH	Einstell-Schlüssel Speichenradnippel	wire wheel spoke wrench	BN1-BJ8	1
F17SPT	Steckschlüssel Alu eloxiert für Achtkantmuttern	knock off wrench anodised aluminium for octagon wheel nut	BN1-BJ8	1
F18SPT	Steckschlüssel Alu eloxiert für 2-zackige Flügelmutter	knock off wrench anodised aluminium for 2-earried wheel nut	BN1-BJ8	1
F19SPT	Kupfer/Lederhammer	copper hide hammer	BN1-BJ8	1
F30SPT	Speichenrad-Kupferfett (90 gr)	wire wheel hub grease (90 gr)	BN1-BJ8	1
Speichenradzubehör 8 tpi (Grobgewinde)		Wire wheel accessories 8 tpi (coarse thread)		
F12SPTR	Achtkantmutter rechts (Grobgewinde/ 8 tpi)	octagon wheel nut right (coarse thread/8 tpi)	BJ8>26705	2
F12SPTL	Achtkantmutter links (Grobgewinde/ 8 tpi)	octagon wheel nut left (coarse thread/8 tpi)	BJ8>26705	2
F13SPTR	2-zackige Flügelmutter rechts (Grobgew./ 8 tpi)	2-earried wheel nut right (coarse thread/8 tpi)	BJ8>26705	2
F13SPTL	2-zackige Flügelmutter links (Grobgew./ 8 tpi)	2-earried wheel nut left (coarse thread/8 tpi)	BJ8>26705	2
F14SPTR	3-zackige Flügelmutter rechts (Grobgew./ 8 tpi)	3-earried wheel nut right (coarse thread/8 tpi)	BJ8>26705	2
F14SPTL	3-zackige Flügelmutter links (Grobgew./ 8 tpi)	3-earried wheel nut left (coarse thread/8 tpi)	BJ8>26705	2
Speichenradzubehör 12 tpi (Feingewinde)		Wire wheel accessories 12 tpi (fine thread)		
F18MGA-36	Achtkantmutter rechts (Feingewinde/12 tpi)	octagon wheel nut right (fine thread /12 tpi)	BN1-BJ8<26704	2
F19MGA-36	Achtkantmutter links (Feingewinde/12 tpi)	octagon wheel nut left (fine thread /12 tpi)	BN1-BJ8<26704	2
F22MGA-36	2-zackige Flügelmutter rechts (Feingew./12 tpi)	2-earried wheel nut right (fine thread /12 tpi)	BN1-BJ8<26704	2
F23MGA-36	2-zackige Flügelmutter links (Feingew./12 tpi)	2-earried wheel nut left (fine thread /12 tpi)	BN1-BJ8<26704	2
F24MGA-36	3-zackige Flügelmutter rechts (Feingew./12 tpi)	3-earried wheel nut right (fine thread/ 12 tpi)	BN1-BJ8<26704	2
F25MGA-36	3-zackige Flügelmutter links (Feingew./12 tpi)	3-earried wheel nut left (fine thread/ 12 tpi)	BN1-BJ8<26704	2
Minilite Style		Minilite style		
F54TR	Minilite Aluminium-Felge 5 1/2 x 15" (Zentralverschluss)	Minilite alloy wheel 5 1/2 x 15" (centre lock)	BN1-BJ8	4
F50AH	Minilite Aluminium-Felge 5 1/2 x 15" (Bolt-On)	Minilite alloy wheel 5 1/2 x 15" (bolt-on)	BN1-BJ8	4
F51TR	Minilite verchromte Radmutter für F50AH	Minilite chromed steel wheel nut to no. F50AH	BN1-BJ8	20

Alle Chromspeichenräder jetzt mit Edelstahlspeichen. Wir gewähren **2 Jahre Garantie** auf alle Speichenräder. – Einzelne Speichen auf Anfrage!

The wire wheels are equipped with stainless steel spokes. All our wire wheels with 2 years-guarantee. – Single spokes on demand!

Trommelbremse vorne / Drum brake front BN1, BN2, BN4, BN6

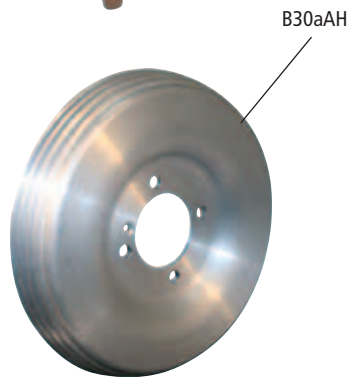
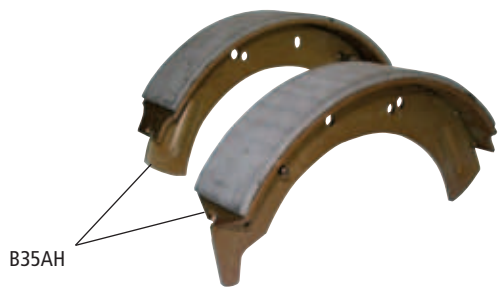
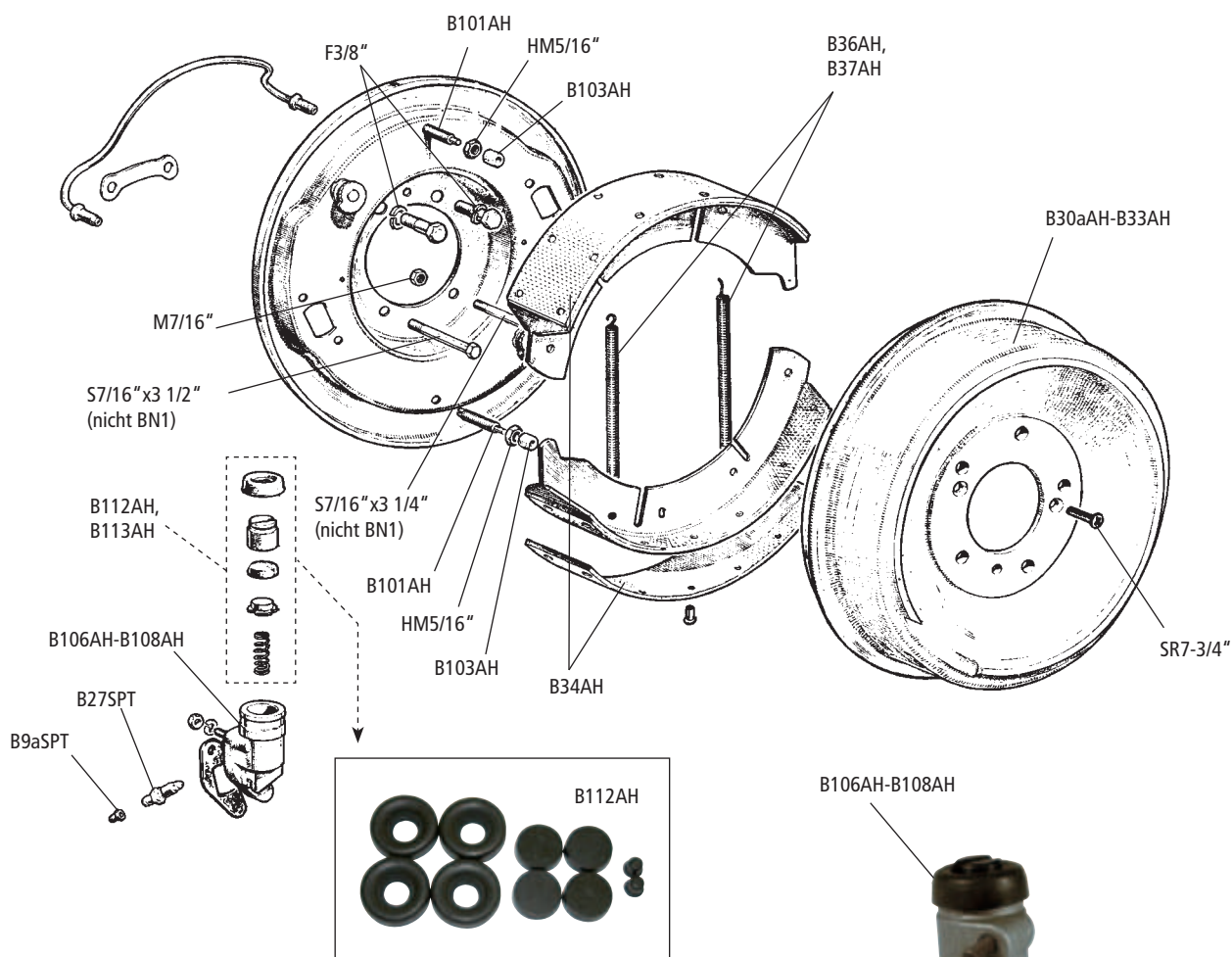

Umbausätze auf Scheibenbremse (vorne)

– Conversion kits to front disc brake!

- BN1
- BN2-BN4/BN6



B45AH/BN1



Montageanleitung auf der Internetseite / Fitting instructions on our website

Trommelbremse vorne / Front drum brake BN1, BN2, BN4, BN6

No.	Bezeichnung	Description	Type	Anzahl/ Qty.
SR7-3/4"	Senkkopfschraube 1/4"x3/4" UNC (Stahlfelge)	countersunk screw 1/4"x3/4" UNC (steel wire)	BN4-BN6	4
B9a5PT	Abdeckkappe Entlüftungsnippel	dust cap, bleed screw	BN1-BN6	4
B275PT	Entlüftungsnippel	bleed screw	BN1-BN6	4
B30aAH	Bremstrommel vorne Aluminium	aluminium front brake drum	BN1<228046	2
B31AH	Bremstrommel vorne „Speichenfelge“	front brake drum „wire wheel“	BN1>228047-BN4/BN6<68960	2
B32AH	Bremstrommel vorne „Stahlfelge“	front brake drum „steel wheel“ front brake	BN4/BN6	2
B33AH	Bremstrommel vorne „Speichenfelge“	drum „wire wheel“	BN6>68961	2
B34AH	Satz (4) Bremsbacken vorne, zum Aufnieten	set (4) front brake shoe liners	BN1	1
B34AH-AT	AT-Bremsbacken Satz (4)	set (4) front brake shoes, exchange	BN1	1
B35AH	Satz (4) Bremsbacken vorne	set (4) front brake shoes	BN2-BN6	1
B36AH	Rückholfeder Bremsbacken vorne	pull-off spring brake shoes	BN1, BN4/BN6<68960	4
B37AH	Rückholfeder Bremsbacken vorne „Speichenfelge“	pull-off spring brake shoe „wire wheel“	BN2-BN6	4
B45AH/BN1	Umbausatz Scheibenbremse vorne	conversion kit to front disc brake	BN1	1
B45AH/BN2	Umbausatz Scheibenbremse vorne - mit TÜV-Gutachten	conversion kit to front disc brake - with TÜV-approval	BN2-BN4/BN6	1
B101AH	Einsteller Bremsbacken	post, steady	BN2-BN6	4
B103AH	Filz Distanzbuchse	bush, felt	BN1-BN6	4
B106AH	Radbremszylinder rechts	wheel cylinder r/h	BN1>221404	2
B107AH	Radbremszylinder links	wheel cylinder l/h	BN1>221404	2
B108AH	Radbremszylinder rechts	wheel cylinder r/h	BN1<221403	2
B108AH	Radbremszylinder rechts für Speichenfelge	wheel cylinder r/h „wire wheels“	BN2-BN6	2
B109AH	Radbremszylinder links	wheel cylinder l/h	BN1<221403	2
B109AH	Radbremszylinder links für Speichenfelge	wheel cylinder l/h „wire wheels“	BN2-BN6	2
B110AH	Radbremszylinder vorne rechts für Stahlfelge	wheel cylinder r/h front „steel wheel“	BN4/BN6	2
B111AH	Radbremszylinder vorne links für Stahlfelge	wheel cylinder l/h front „steel wheel“	BN4/BN6	2
B112AH	Rep.satz Radbremszylinder für B108AH/B109AH	repair kit wheel cylinder B108AH/B109AH	BN1<221403	2
B112aAH	Rep.satz Radbremszylinder für B106AH/B107AH	repair kit wheel cylinder B106AH/B107AH	BN1-BN2	2
B113AH	Rep.satz Radbremszylinder für B110AH/B111AH	repair kit wheel cylinder B110AH/B111 AH	BN4-BN6	2



Scheibenbremse vorne / Front disc brake BN7, BT7, BJ7, BJ8 < 26704

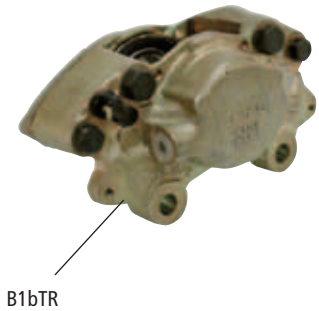
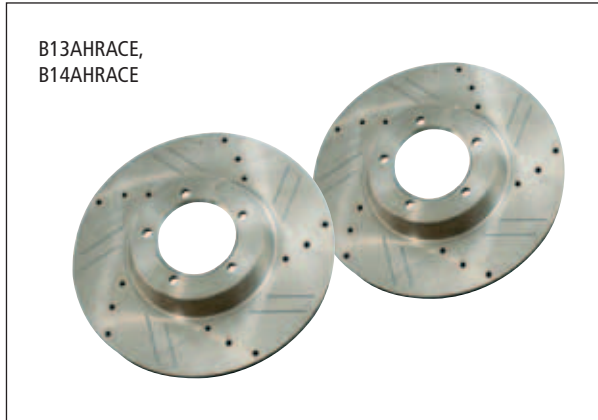
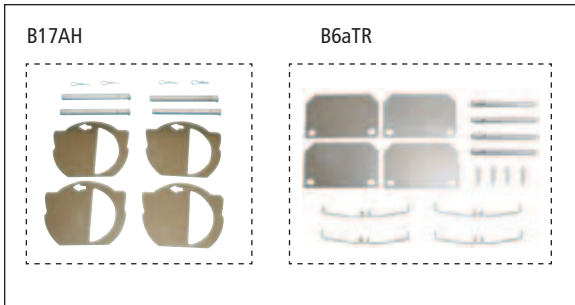
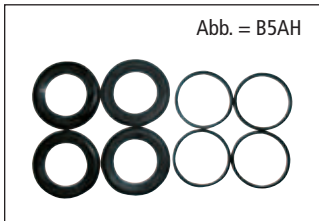
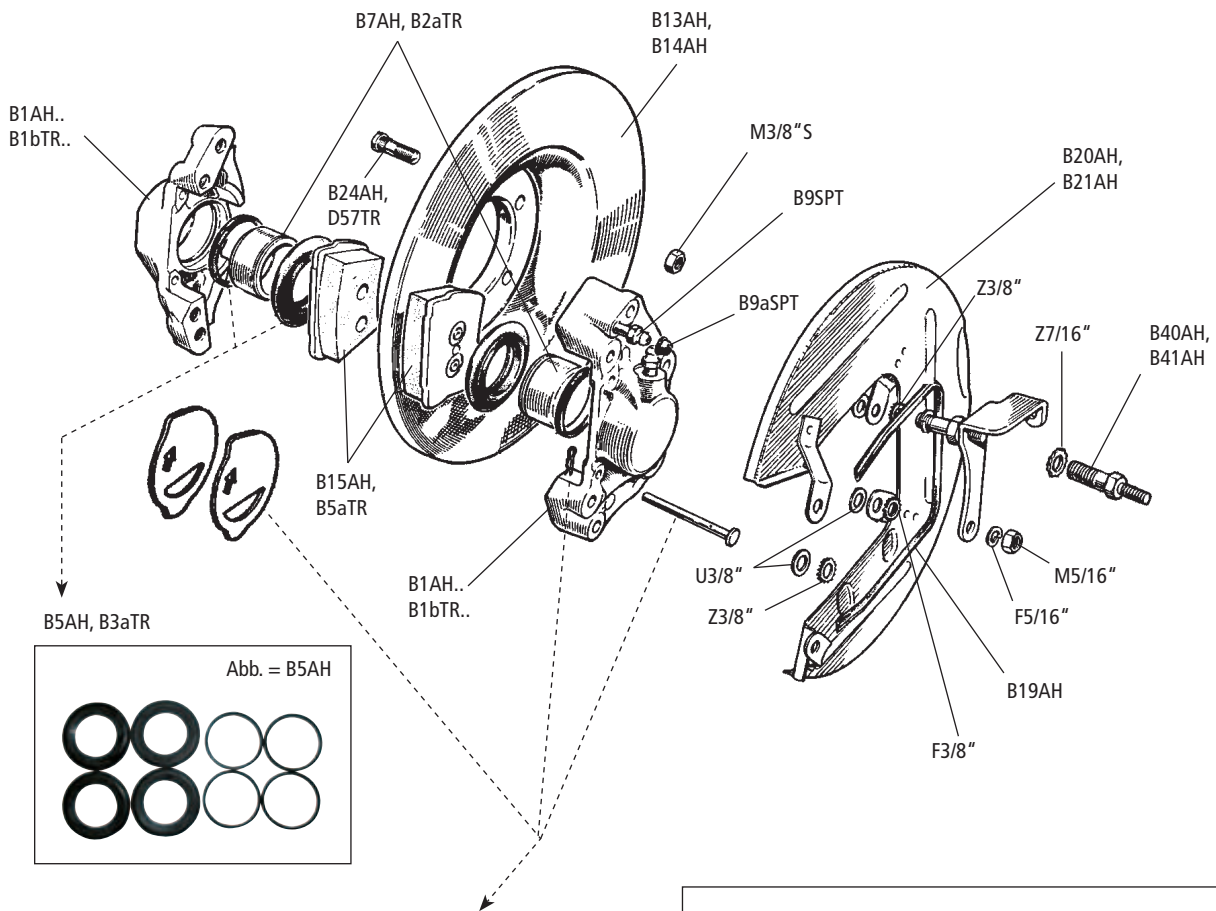

Scheibenbremse vorne / Front disc brake BN7, BT7, BJ7, BJ8 < 26704

No.	Bezeichnung	Description	Type	Anzahl/Qty.
B1AHR	Bremszange rechts	caliper right	BN7,BT7,BJ7,BJ8<26704	1
B1AHL	Bremszange links	caliper left	BN7,BT7,BJ7,BJ8<26704	1
B5AH	Reparatur-Satz Bremszange (2 Bremszangen)	caliper repair kit (2 calipers)	BN7,BT7,BJ7,BJ8<26704	1
B7AH	Kolben Bremszange	caliper piston	BN7,BT7,BJ7,BJ8<26704	4
B9SPT	Entlüftungsnippel Bremszange	air bleed screw	BN7,BT7,BJ7,BJ8<26704	2
B9aSPT	Abdeckkappe Entlüftungsnippel	dust cap, bleed screw	BN7,BT7,BJ7,BJ8<26704	2
B13AH	Bremsscheibe	brake disc	BN7,BT7,BJ7,BJ8<26704	1
B13AHRACE	Paar Bremsscheiben gelocht, geschlitzt	pair grooved brake discs	BN7,BT7,BJ7,BJ8<26704	1
B15AH	Satz (4) Bremsbeläge	set (4) brake pads	BN7,BT7,BJ7,BJ8<26704	1
B17AH	Satz (4) Befestigungsstifte/Splinte/ Antiquietschplättchen	set (4) front brake pad pins/shims/clips/ anti-squel kit	BN7,BT7,BJ7,BJ8<26704	1
B19AH	Gummi, Schutzplatte Bremsscheibe	rubber dustshield brake disc	BN7,BT7,BJ7,BJ8<26704	2
B20AHR	Schutzplatte Bremsscheibe rechts	dustshield caliper right	BN7,BT7,BJ7,BJ8<26704	1
B20AHL	Schutzplatte Bremsscheibe links	dustshield caliper left	BN7,BT7,BJ7,BJ8<26704	1
B24AH	Bolzen Bremsscheibe	bolt brake disc	BN7,BT7,BJ7,BJ8<26704	10
B40AH	Befestigungsschraube Bremszange	caliper mounting	BN7,BT7,BJ7,BJ8<26704	4

Scheibenbremse vorne / Front disc brake BJ8 > 26705

No.	Bezeichnung	Description	Type	Anzahl/Qty.
B1bTRR	Bremszange rechts	caliper right	BJ8>26705	1
B1bTRL	Bremszange links	caliper left	BJ8>26705	1
B2ATR	Kolben Bremszange	caliper piston	BJ8>26705	4
B3aTR	Reparatur-Satz Bremszange (2 Bremszangen)	caliper repair kit (2 calipers)	BJ8>26705	1
B5bTRCRACE	Satz (4) Bremsklötze Carbon für Sportzwecke	set (4) brake pads carbon, for competition use	BJ8>26705	1
B5aTR	Satz (4) Bremsbeläge	set (4) brake pads	BJ8>26705	1
B6aTR	Satz (4) Befestigungsstifte/Splinte/ Antiquietschplättchen	set (4) front brake pad pins/shims/clips/ anti-squel kit	BJ8>26705	1
B9SPT	Entlüftungsnippel Bremszange	air bleed screw	BJ8>26705	2
B9aSPT	Abdeckkappe Entlüftungsnippel	dust cap, bleed screw	BJ8>26705	2
B14AH	Bremsscheibe	brake disc	BJ8>26705	1
B14AHRACE	Paar Bremsscheiben gelocht, geschlitzt	pair grooved brake discs	BJ8>26705	1
B21AHR	Schutzplatte Bremsscheibe rechts	dustshield caliper right	BJ8>26705	1
B21AHL	Schutzplatte Bremsscheibe links	dustshield caliper left	BJ8>26705	1
B41AH	Befestigungsschraube Bremszange	caliper mounting bolt	BJ8>26705	4
D57TR	Bolzen Bremsscheibe	bolt brake disc	BJ8>26705	10
M3/8" S	Selbstsichernde Mutter Bremsscheibe	nut nyloc brake disc bolt	BJ8>26705	10

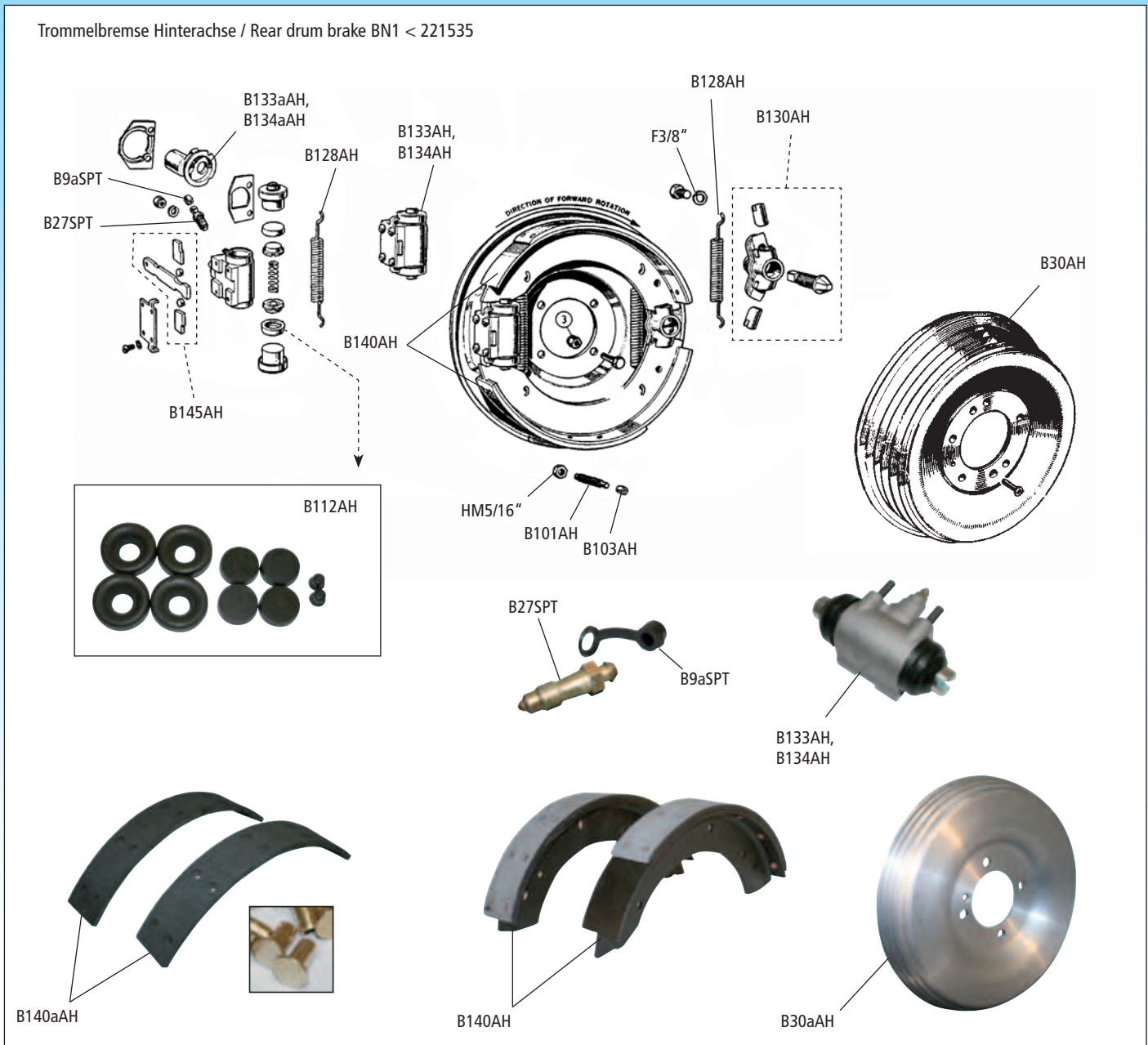
Bremse Hinterachse / Rear brakes BN1 < 221535 (Spiral Bevel Axle)

No.	Bezeichnung	Description	Type	Anzahl/Qty.
B9aSPT	Abdeckkappe Entlüftungsrippel	cap air bleed screw	BN1<221535	2
B27SPT	Entlüftungsrippel	air bleed screw	BN1<221535	2
B30AH	Bremstrommel	brake drum	BN1<221535	2
B30aAH	Bremstrommel Aluminium	aluminium brake drum	BN1<221535	2
B101AH	Einsteller Bremsbacken	steady post brake shoes	BN1<221535	4
B103AH	Filzbuchse	felt bush steady post	BN1<221535	4
B112AH	Rep.satz Radbremszylinder	repair kit wheel cylinder	BN1<221535	1
B128AH	Rückholfeder Bremsbacken	pull-off spring rear brake shoes	BN1<221535	4
B130AH	Bremseinsteller	adjuster unit assembly	BN1<221535	2
B133AH	Radbremszylinder rechts	wheel cylinder RH	BN1<221535	1
B133aAH	Staubkappe Radbremszylinder rechts	dust cover wheel cylinder RH	BN1<221535	1
B134AH	Radbremszylinder links	wheel cylinder LH	BN1<221535	1
B134aAH	Staubkappe Radbremszylinder links	dust cover wheel cylinder LH	BN1<221535	1
B140AH	Satz (4) AT-Bremsbacken	set (4) brake shoes, exchange	BN1<221535	1
B140aAH	Satz (4) Bremsbeläge zum Aufnieten	set (4) front brake shoe liners	BN1<221535	1
B145AH	Hebel- und Rollenset Handbremse	roller and drawlink set handbrake	BN1<221535	2

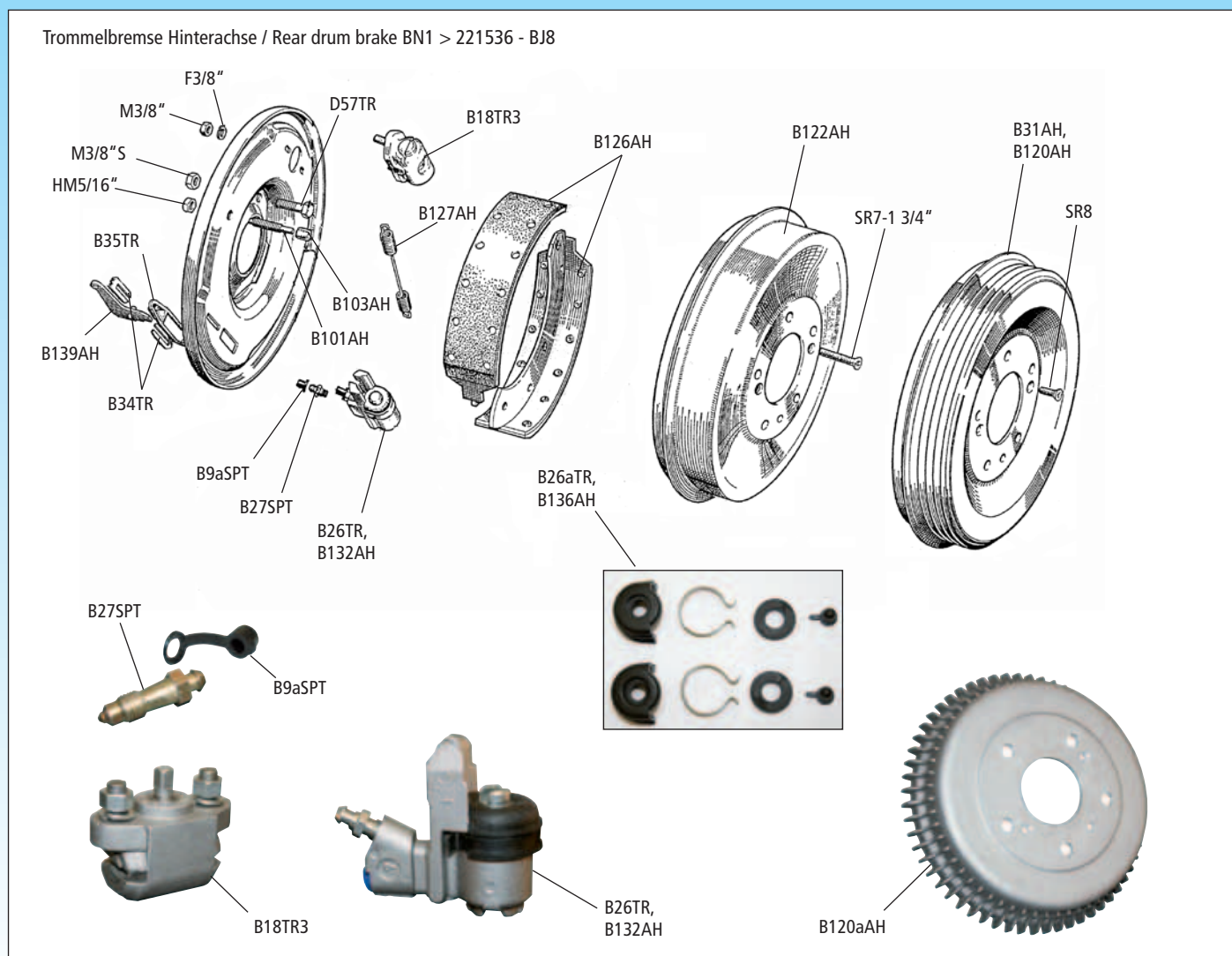

Bremse Hinterachse / Rear brakes BN1 > 221536 - BJ8 (Hypoid Axle)

No.	Bezeichnung	Description	Type	Anzahl/Qty.
HM5/16"	Kontermutter Einsteller Bremsbacken	jam nut adjusting steady post	BN1>221536-BJ8	4
SR7-1 3/4"	Senkkopfschraube Bremstrommel (Stahlfelge)	countersunk screw brake drum (steel wheel)	BN1>221536-BJ8	4
SR8	Senkkopfschraube Bremstrommel (Speichenrad)	countersunk screw brake drum (wire wheel)	BN1>221536-BJ8	4
B9aSPT	Abdeckkappe Entlüftungsrippel	cap air bleed screw	BN1>221536-BJ8	1
B18TR3	Brems-Einstell-Einheit	adjuster unit assembly	BN1>221536-BJ8	2
B26TR	Radzylinder	rear wheel cylinder	BN7-BT7-BJ8	2
B26aTR	Reparatur-Satz Radzylinder	rep.-kit rear wheel cylinder	BN7-BT7-BJ8	1
B27SPT	Entlüftungsrippel Radzylinder	air bleed screw wheel cylinder	BN1-BJ8	1
B31AH	Bremstrommel Speichenrad	rear brake drum wire wheel	BN1>221536-BN6	2
B34TR	Befestigungssatz Radbremszylinder	locking kit wheel cylinder	BN1-BJ8	1
B35TR	Staubkappe Radbremszylinder	dust cover wheel cylinder	BN1-BJ8	2
D57TR	Befestigungsbolzen Bremsankerplatte	bolt, plate to axle case	BN1>221536-BJ8	8
B101AH	Einsteller Bremsbacken	steady post brake shoes	BN1-BJ8	4
B103AH	Filz-Distanzbuchse Bremssteller	felt bush steady post	BN1>221536-BN6	4
B120AH	Bremstrommel Speichenrad	rear brake drum wire wheel	BN7-BT7-BJ8	2
B120aAH	„Alfin“ Aluminium Bremstrommel	„Alfin“ aluminium brake drum	BN1>221536-BJ8	2
B122AH	Bremstrommel Stahlfelge	rear brake drum steel wheel	BN4-BJ8	2
B126AH	Satz (4) Bremsbacken	set (4) rear brake shoes	BN1>221536-BJ8	1
B127AH	Rückholfeder Bremsbacken	pull-off spring rear brake shoes	BN1>221536-BJ8	4
B132AH	Radzylinder	rear wheel cylinder	BN1>221536-BN6	2
B136AH	Reparatur-Satz Radzylinder	rep.-kit rear wheel cylinder	BN1>221536-BN6	1
B139AH	Hebel Handbremsseil hinten	handbrake lever on backplate	BN1-BJ8	2

• BN1-BN2



• BN4-BJ8

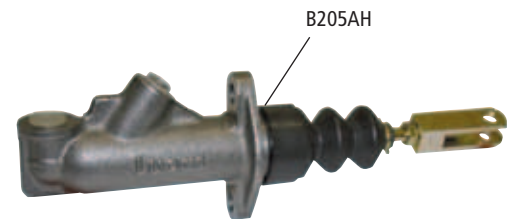
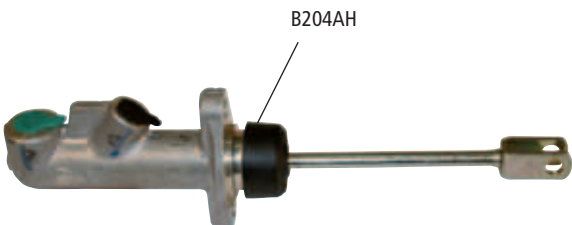
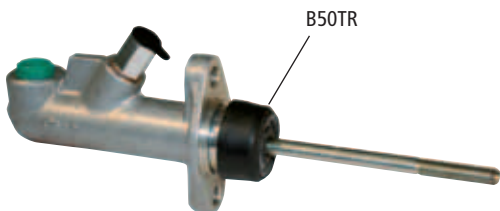
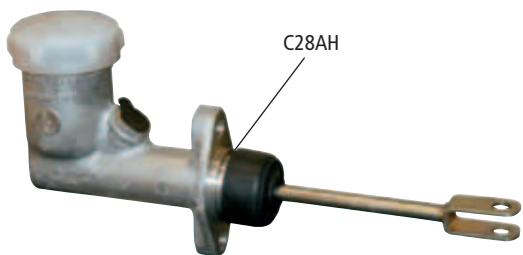

BN1-BN2 RHD

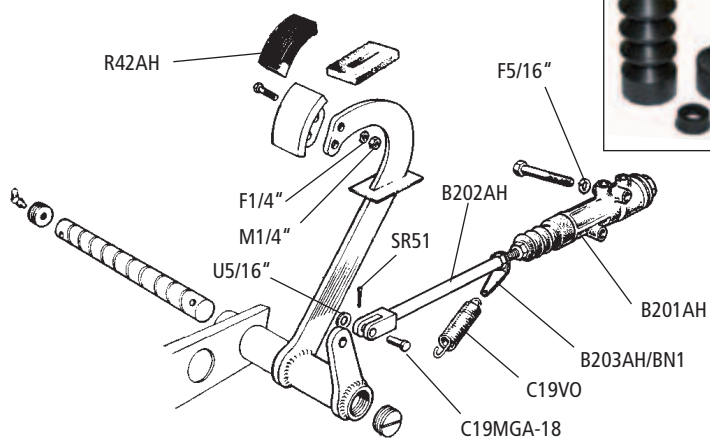

BN4-BJ8

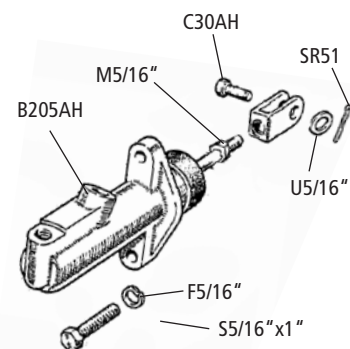
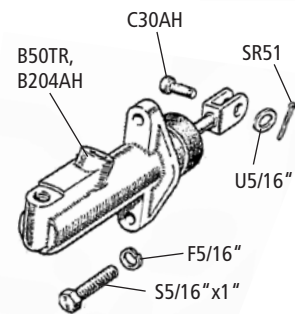
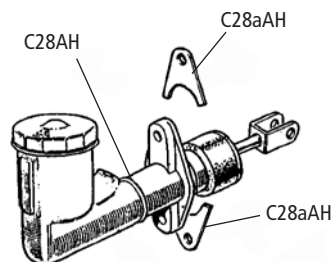
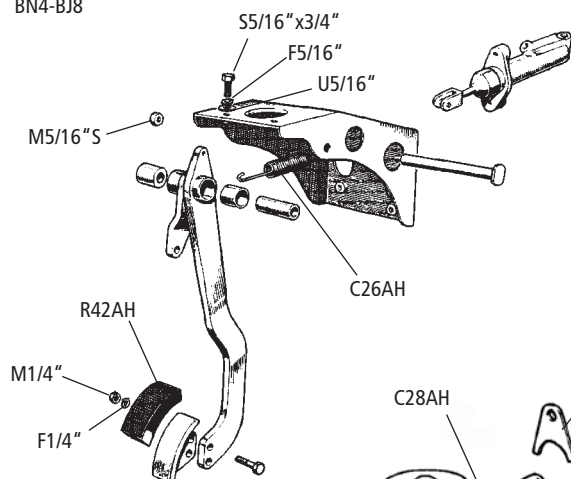

No.	Bezeichnung	Description	Type	Anzahl/Qty.
C19MGA-18	Verbindungsstift	clevis pin	BN1-BN2	1
R42AH	Pedalgummi	pedal rubber	BN1-BJ8	2
B50cTR	Deckel Bremsflüssigkeitsbehälter	cover brake fluid reservoir	BN1-BJ8	1
B50dTR	Dichtung für Deckel Bremsflüssigkeitsbehälter	seal, filler cap	BN1-BJ8	1
SR51	Splint	split pin	BN1-BN2	1
B201AH	Hauptbremszylinder	brake master cylinder	BN1-BN2	1
B202AH	Druckstange Hauptbremszylinder LHD	fork and extension, pushroad	BN1-BN2	1
B206AH	Reparatur-Satz Hauptbremszylinder	rep.-kit brake master cylinder	BN1-BN2	1
B207AH	Staubschutzabdeckung (Paar) Pedalbefestigung/Spritzwand	dust excluders, pedal (pair)	BN1-BN2	1
B213AH	Flüssigkeitsbehälter Bremsflüssigkeit	brake fluid reservoir	BN1-BN2	1

No.	Bezeichnung	Description	Type	Anzahl/Qty.
C6SPT	Reparatur-Satz Hauptbremszyl. B204AH	rep.-kit brake master cyl. no. B204AH	BN7,BT7,BJ8	1
C19VO	Zugfeder hydraulische Kupplung	spring, brake pedal return	BN1-BN2	1
C26AH	Rückholfeder Pedal	spring, brake pedal return	BN4-BJ8	1
C28AH	Hauptbremszylinder (Behälter integriert)	brake master cylinder (integr. reservoir)	BN4<48862	1
C28aAH	Halter Hauptbremszylinder	bracket, master cylinder	BN4-BJ8	2
R42AH	Pedalgummi	pedal rubber	BN1-BJ8	2
B50bTR	Vorratsbehälter Kupplungsflüssigkeit/Bremsflüssigkeit	brake fluid reservoir, brake and clutch	BN4>48862-BJ8	1
B50cTR	Deckel Bremsflüssigkeitsbehälter	cover brake fluid reservoir	BN1-BJ8	1
B50dTR	Dichtung für Deckel Bremsflüssigkeitsbehälter	seal, filler cap	BN1-BJ8	1
B51aTR	Reparatur-Satz zu Hauptbremszyl. C28AH + B50TR	rep.-kit to brake master cylinder no. C28AH + B50TR		1
B50TR	Hauptbremszylinder, separater Behälter	brake master cylinder (separ. reservoir)	BN4>48862-BN6	1
B203AH/BN1	Halteleiste Rückholfeder	retaining plate spring	BN1-BN2	1
B204AH	Hauptbremszylinder, separater Behälter (ohne Servo)	brake master cylinder, separate reservoir (without servo)	BN7,BT7,BJ7	1
B205AH	Hauptbremszylinder, separater Behälter (für Servo)	brake master cylinder, separate reservoir (for servo)	BN7,BT7,BJ8	1
B210AH	Reparatur-Satz zu Hauptbremszyl. B205AH	rep.-kit to brake master cyl. no. B205AH		1
B215AH	Halter Bremsflüssigkeitsbehälter	strap brake fluid reservoir	BJ8	1
B216AH	Halter Bremsflüssigkeitsbehälter RHD	strap brake fluid reservoir rhd	BJ8	1
B219AH	Halter Bremsflüssigkeitsbehälter LHD	strap brake fluid reservoir lhd	BN4>48862-BJ8	1

BR05	Bremsflüssigkeit 1/2 l DOT4	brake fluid 1/2 l DOT4	
BRSi-05	Silikon Bremsflüssigkeit 1/2 l *	silicone brake fluid 1/2 l *	* Anmerkungen zu BR-Si05, BR-Si1: siehe Seite 71 * note to BR-Si05, BR-Si1: see page 71
BRSi-1	Silikon Bremsflüssigkeit 1 l *	silicone brake fluid 1 l *	

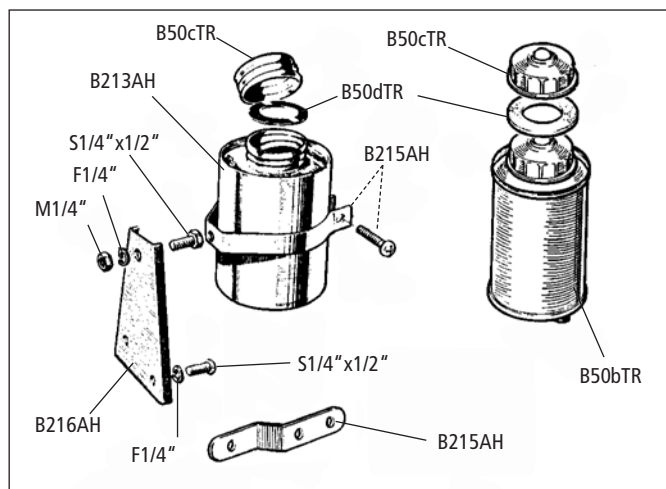
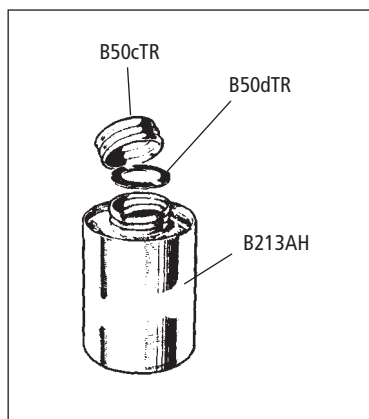

Für alle Austin-Healey geeignet!

– suitable for all Austin-Healey models

Bremskraftverstärker/Servo

- Einfache Montage
- Komplett mit allen Teilen und Bedienungsanleitung

Servo Brake Unit

- Easy fitting
- Complete kit with fitting instructions

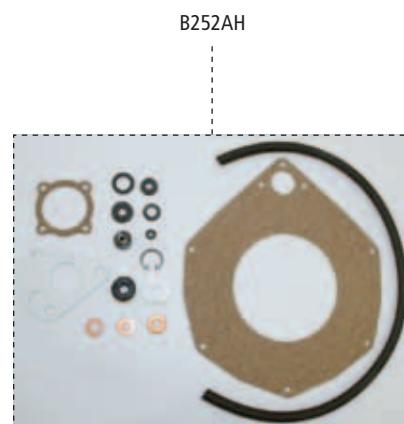
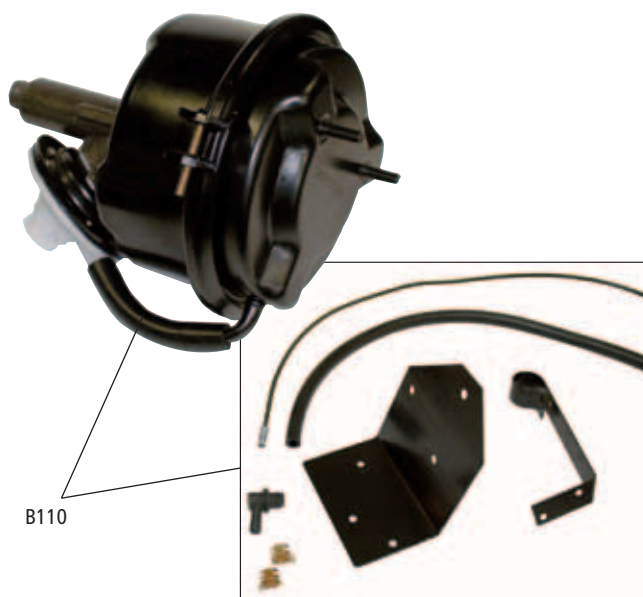
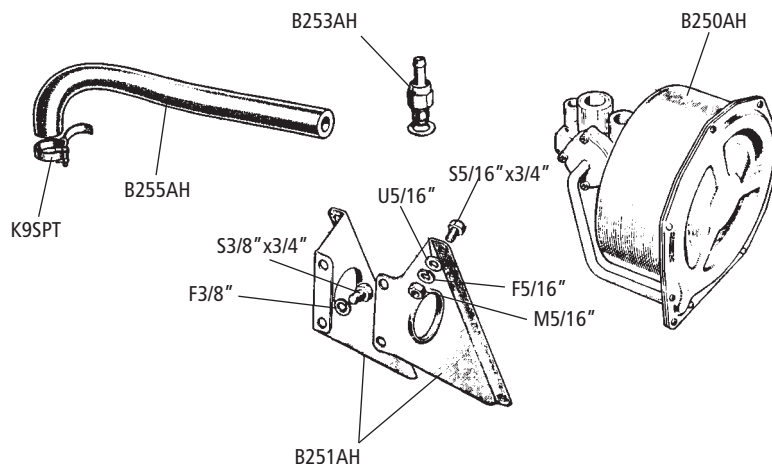
**Bremskraftverstärker / Servo brake unit**

No.	Bezeichnung	Description	Type	Anzahl/Qty.
B110	Bremskraftverstärker Satz zum Nachrüsten, für alle Fahrzeuge, die nicht über einen Bremskraftverstärker verfügen oder als Ersatz für den zeitweise nicht lieferbaren Original-Bremskraftverstärker B250AH	optional servo brake unit, complete kit as option for all non servo cars, or as replacement servo unit instead of the no longer available original brake servo B250AH	BN1-BJ8	1
B250AH	Bremskraftverstärker/Servo	servo brake unit	BN7,BT7,BJ7,BJ8	1
B251AH	Paar Haltebleche für Bremskraftverstärker	fixing bracket servo brake unit	BN7,BT7,BJ7,BJ8	1
B252AH	Reparatur-Satz Bremskraftverstärker	repair kit servo brake unit	BN7,BT7,BJ7,BJ8	1
B253AH	Rückschlagventil Original Bremskraftverstärker	non return valve original servo unit	BN7,BT7,BJ7,BJ8	1
B255AH	Unterdruckschlauch Bremskraftverstärker	vacuum hose brake servo unit	BN7,BT7,BJ7,BJ8	1
K9SPT	Schlauchselle 12-20 mm	retaining clip 12-20 mm	BN7,BT7,BJ7,BJ8	2

BN1-BN6

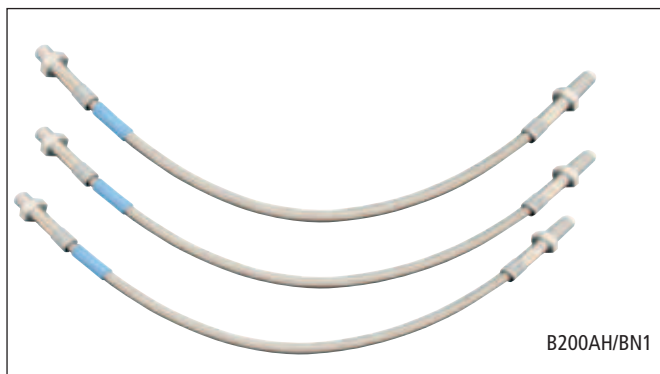

B200AH/BN1

BJ7/BT7/BN7/BJ8

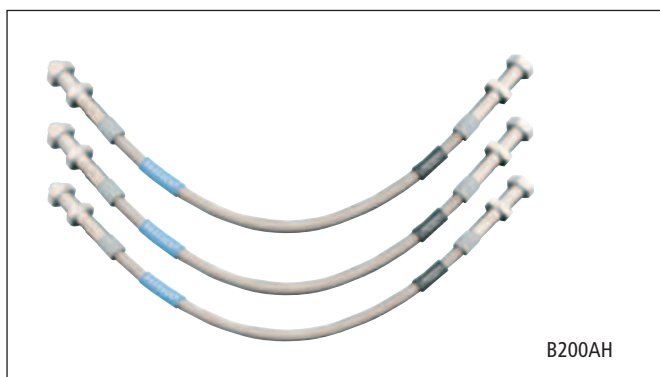

B200AH

Stahlummantelte Brems- schläuche – mit TÜV-Gutachten!

- Super Optik
- härterer Pedaldruck
- kürzerer Pedalweg

Steel coated brake hoses – with TÜV Approval!

- perfect finish
- improved pedal feeling
- less pedal travel

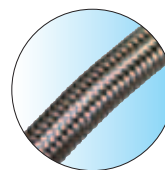

Bremsschläuche, -leitungen / Brake pipes & hoses

No.	Bezeichnung	Description	Type	Ben. Anzahl/ Qty. Req.
B56TRAQ	Bremsschlauch stahlummantelt hinten (ersetzt B56TR) - mit TÜV-Gutachten	steel coated brake hose, rear (replaces B56TR) - with TÜV-approval	BN1-BN6	1
B56aTRAQ	Bremsschlauch stahlummantelt vorne (ersetzt B60SPT1500) - mit TÜV-Gutachten	steel coated brake hose, front (replaces B60SPT1500) - w. TÜV-approval	BN7,BT7,BJ7,BJ8	2
B59MGBAQ	Bremsschlauch stahlummantelt hinten (ersetzt B56TR2000) - mit TÜV-Gutachten	steel coated brake hose, rear (replaces B56TR2000) - w. TÜV-approval	BN7,BT7,BJ7,BJ8	1
B59SPTAQ	Bremsschlauch stahlummantelt vorne (ersetzt B59SPT) - mit TÜV-Gutachten	steel coated brake hose, front (replaces B59SPT) - w. TÜV-approval	BN1-BN6	2
B200AH/BN1	Satz Bremsschläuche stahlummantelt (3-teilig) - mit TÜV-Gutachten	set steel coated brake hoses (3 pcs.) with TÜV approval	BN1-BN6	1
B200AH	Satz Bremsschläuche stahlummantelt (3-teilig) - mit TÜV-Gutachten	set steel coated brake hoses (3 pcs.) with TÜV approval	BJ7,BT7,BN7,BJ8	1



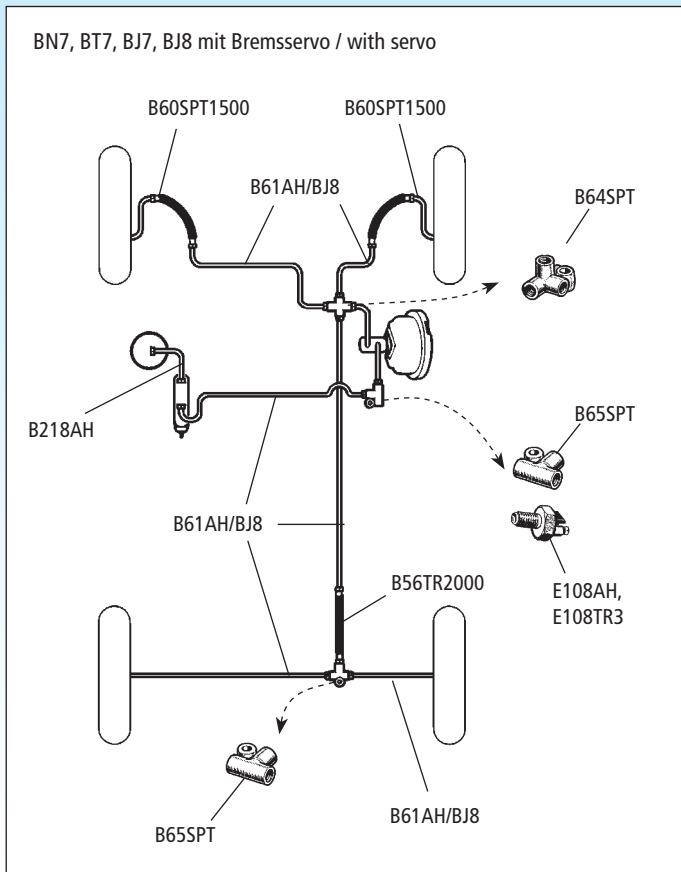
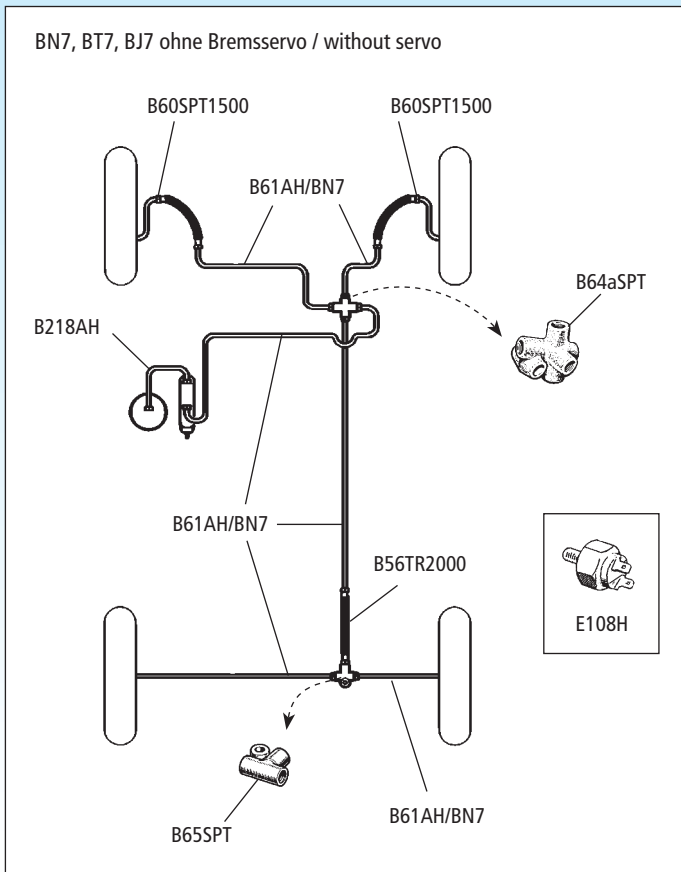
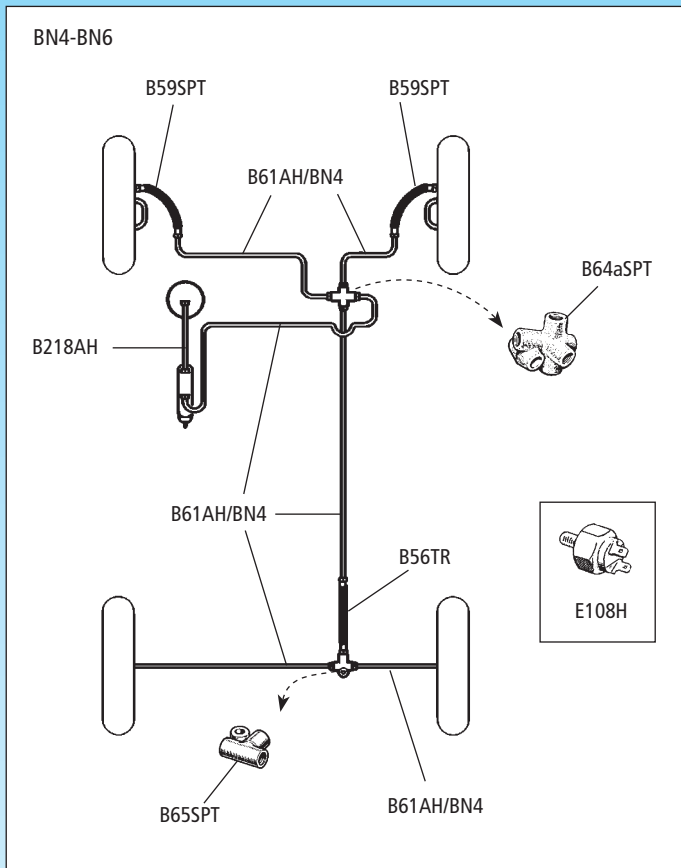
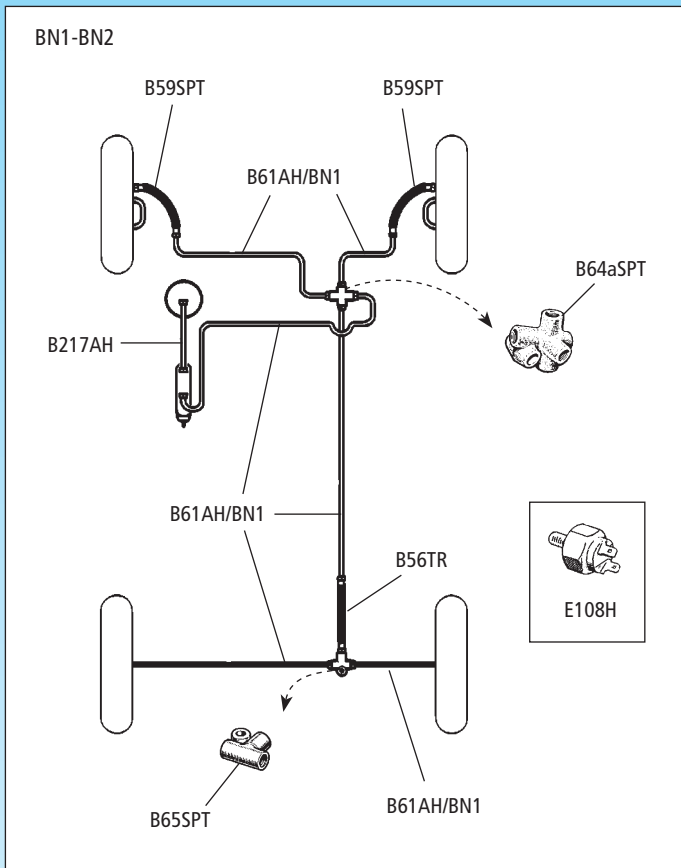

Hinweis: alle Illustrationen zeigen LHD Fahrzeuge
 Note: all illustrations refer to LHD models

Stahlmantelerte Brems-schläuche - s. Seite 119
 - Steel coated brake hoses - please refer page 119 -

Bremsschläuche, -leitungen / Brake pipes & hoses

No.	Bezeichnung	Description	Type	Anzahl/Qty.
B56TR	Bremsschlauch hinten	brake hose rear	BN1-BJ6	1
B56TR2000	Bremsschlauch hinten	brake hose, rear	BN7,BT7,BJ7,BJ8	1
B58b	Kontermutter Bremsschlauch	nut,hose to pipe	BN1-BJ8	1
B58c	Kupferdichtung für Bremsschlauch	copper washer	BN1-BJ8	1
B58d	Zahnscheibe für Bremsschlauch	washer, shakeproof	BN1-BJ8	1
B59SPT	Bremsschlauch vorne	brake hose front	BN1-BN6	2
B60SPT1500	Bremsschlauch vorne	brake hose front	BN7,BT7,BJ7,BJ8	2
B61AH/BN1	Bremsleitungssatz Kunifer* LHD	Kunifer* brake pipe set LHD	BN1,BN2	1
B61AH/BN1RHD	Bremsleitungssatz Kunifer* RHD	Kunifer* brake pipe set RHD	BN1,BN2	1
B61AH/BN4	Bremsleitungssatz Kunifer* LHD	Kunifer* brake pipe set LHD	BN4,BN6	1
B61AH/BN4RHD	Bremsleitungssatz Kunifer* RHD	Kunifer* brake pipe set RHD	BN4,BN6	1
B61AH/BN7	Bremsleitungssatz Kunifer* LHD ohne Bremsservo	Kunifer* brake pipe set LHD w/o servo	BN7,BT7,BJ8	1
B61AH/BN7RHD	Bremsleitungssatz Kunifer* RHD o. Bremsservo	Kunifer* brake pipe set RHD w/o servo	BN7,BT7,BJ8	1
B61AH/BJ8	Bremsleitungssatz Kunifer* LHD mit Bremsservo	Kunifer* brake pipe set LHD with servo	BN7,BT7,BJ7,BJ8	1
B61AH/BJ8RHD	Bremsleitungssatz Kunifer* RHD mit Bremsservo	Kunifer* brake pipe set RHD with servo	BN7,BT7,BJ7,BJ8	1
B64SPT	4-fach-Verteiler	4-way connector	BN1-BJ8	1
B64aSPT	5-fach-Verteiler	5-way connector	BN1-BJ8	1
B65SPT	3-fach Verteiler	3-way connector	BN1-BJ8	1
B80	Anschlußverschraubung für Bremsleitung, Messing 3/8" Außengewinde UNF	brake pipe nut female brass outer thread 3/8" UNF	BN1-BJ8	1
B81	Anschlußverschraubung für Bremsleitung, Messing 3/8" Innengewinde UNF	brake pipe nut male brass inner thread 3/8" UNF	BN1-BJ8	1
B95	3/16" Bremsleitung Kunifer*, pro Meter	3/16" brake pipe Kunifer*, per meter	BN1-BJ8	
B100	Bremsenfett, 5 gr.	brake grease, 5 gr.	BN1-BJ8	A/R
E108H	Bremslicht-Schalter (ohne Bremsservo)	stop lamp switch (without servo)	BN1-BN2,BN7,BT7/BJ7	1
E108TR3	Bremslicht-Schalter, Steckanschluß (mit Servo)	stop lamp switch (with servo)	BN7,BT7,BJ7	1
E108AH	Bremslicht-Schalter	stop lamp switch	BJ8	1
B217AH	Bremsleitung Kunifer* vom Flüssigkeitsbehälter zu Hauptbremszylinder LHD	Kunifer* brake pipe, tank to master cylinder LHD	BN1-BN2	1
B217AH/RHD	Bremsleitung Kunifer* vom Flüssigkeitsbehälter zu Hauptbremszylinder RHD	Kunifer* brake pipe, tank to master cylinder RHD	BN1-BN2	1
B218AH	Bremsleitung Kunifer* vom Flüssigkeitsbehälter zu Hauptbremszylinder LHD	Kunifer* brake pipe, tank to master cylinder LHD	BN4>48863-BJ8	1
B218AH/RHD	Bremsleitung Kunifer* vom Flüssigkeitsbehälter zu Hauptbremszylinder RHD	Kunifer* brake pipe, tank to master cylinder RHD	BN4>48863-BJ8	1
B227AH	Halteclip Bremsleitung	clip, brake pipe	BN1-BJ8	A/R

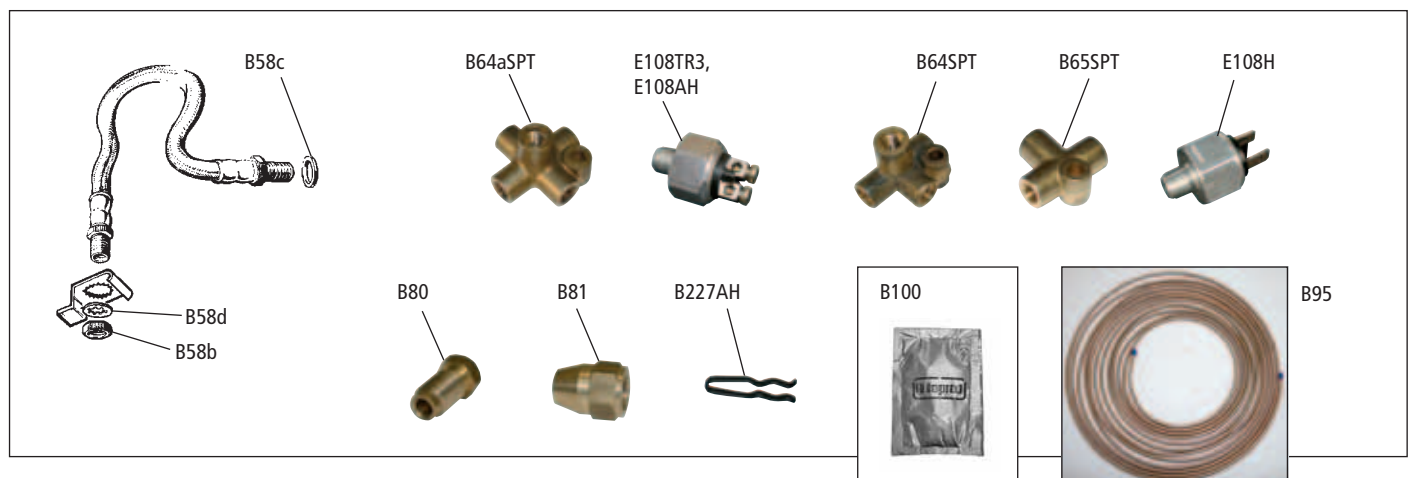
*** Anmerkungen zu Kunifer:**

Kunifer = Korrosionsbeständige Kupfer-Messing-Legierung. Die Bremsleitungen werden mit Messingverschraubungen geliefert.

*** Note to „Kunifer“:**

Kunifer-brake pipe tubing and brass tube nuts. Made from non corroding cupro nickel with lifetime guarantee on anti corrosion

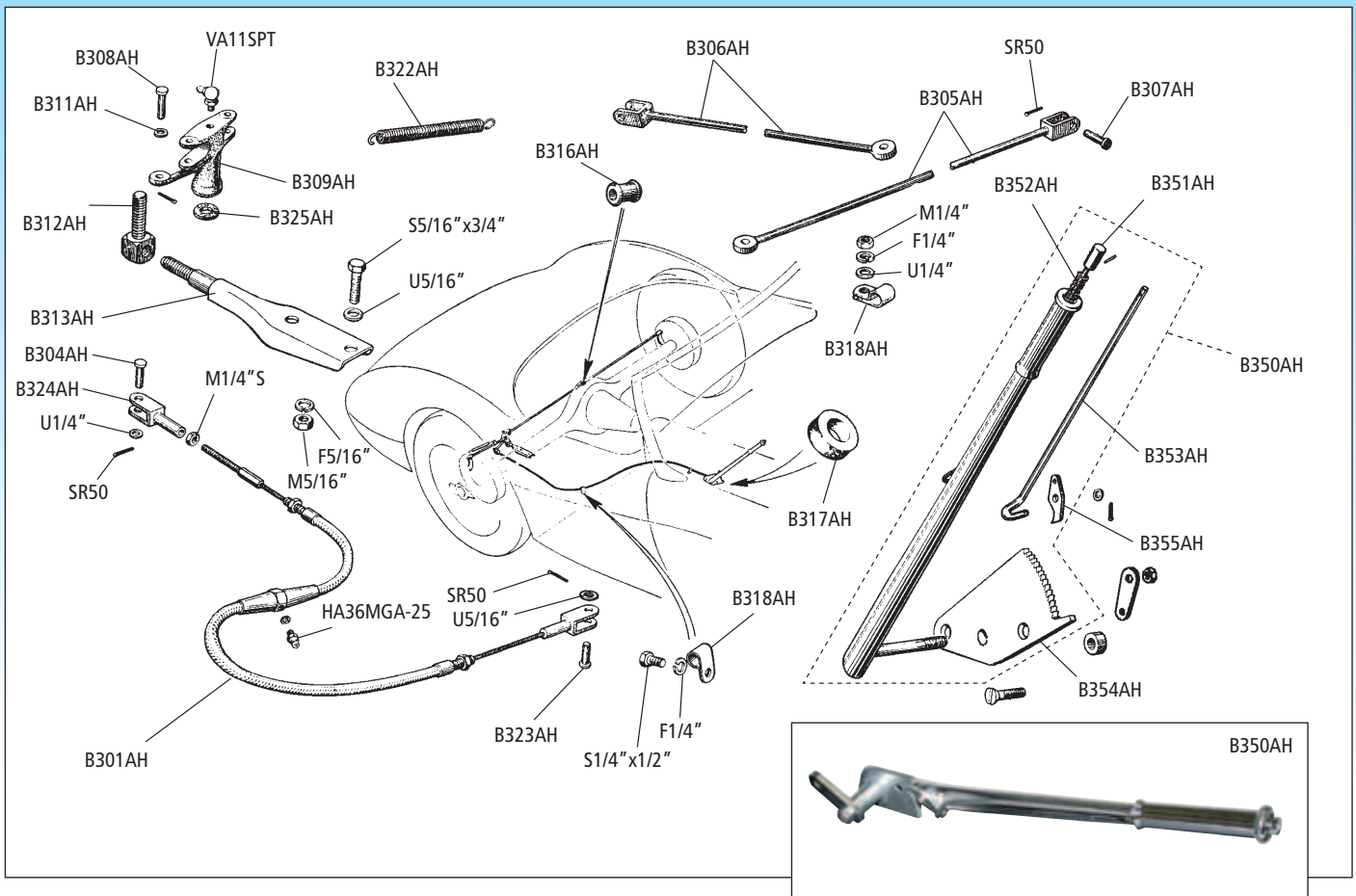

Handbremse / Hand brake

No.	Bezeichnung	Description	Type	Anzahl/Qty.
HA36MGA-25	Schmiernippel	grease nipple	BN1-BJ8	1
B301AH	Handbremsseil hinten	rear handbrake cable	BN1-BJ8	1
B304AH	Sicherungsstift	clevis pin	BN1-BJ8	1
B305AH	Stange Handbremse hinten lang	handbrake link rear axle long	BN1>221536-BJ8	1
B306AH	Stange Handbremse hinten kurz	handbrake link rear axle short	BN1>221536-BJ8	1
B307AH	Stift Handbremsstange	clevis pin	BN1-BJ8	2
B308AH	Sicherungsstift	pin joint handbrake	BN1-BJ8	2
B309AH	Ausgleicher Handbremsseil	balance carrier	BN1>221536-BJ8	1
VA11SPT	Schmiernippel	grease nipple	BN1-BJ8	1
B311AH	Filzscheibe	felt washer	BN1>221536-BJ8	1
B312AH	Ausgleichsstift Handbremse	balance carrier handbrake	BN1>221536-BJ8	1
B313AH	Haltebügel Handbremse hinten Hinterachse	support bracket handbrake	BN1>221536-BJ8	1
B316AH	Gummiführungsbuchse	ferrule-cross rod steady	BN1-BJ8	1
B317AH	Filzlagerbuchse Handbremshebel	felt dust seal	BJ7-BJ8	1
B318AH	Klammer Handbremsseil zu Bodenblech	clip handbrake cable >floor panel	BN1-BJ8	2
B322AH	Rückholfeder Handbremse	return spring handbrake lever	BN1>221536-BJ8	2
B323AH	Stift Handbremse hinten	clevis pin handbrake cross rod	BN1-BJ8	1
B324AH	Gabel Handbremsseil	fork end handbrake cable	BN1-BJ8	1
B325AH	Filzdichtung Ausgleicher	felt, balance carrier	BN1-BJ8	1
B350AH	Handbremshebel komplett	lever hand brake, complete	BN4-BJ8	1
B351AH/BN1	Knopf Handbremse	button hand brake	BN1-BN2	1
B351AH	Knopf Handbremse	button hand brake	BN4-BJ8	1
B352AH	Feder Handbrems-Knopf	spring pawl release	BN1-BJ8	1
B353AH/BN1	Stange in Handbremshebel	link, lever hand brake	BN1-BN2	1
B353AH	Stange in Handbremshebel	link, lever hand brake	BN4-BJ8	1
B354AH	Zahnplatte Handbremshebel	plate, ratchet	BN4-BJ8	1
B355AH	Finger zur Zahnplatte	pawl	BN1-BJ8	1

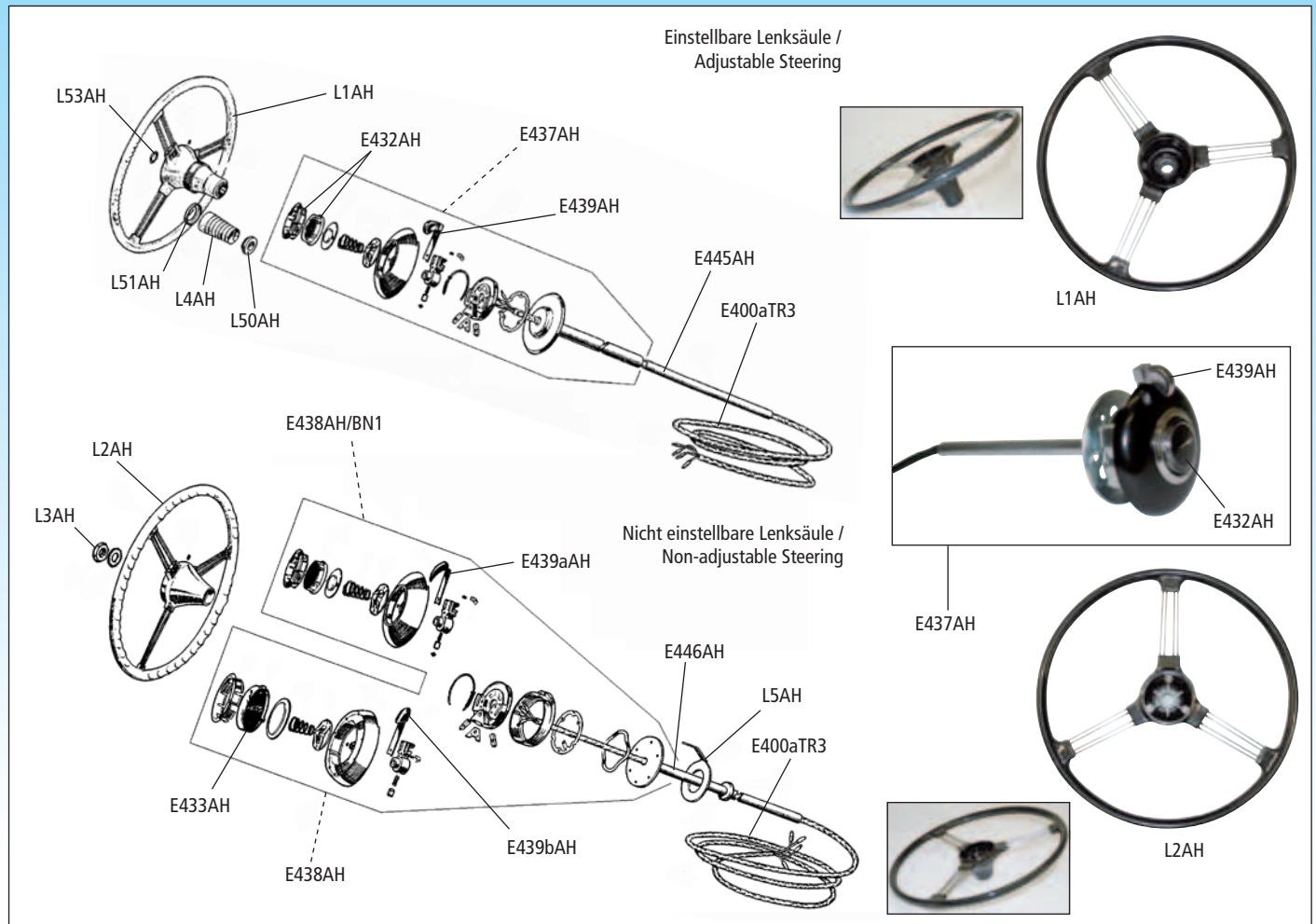

No.	Bezeichnung	Description	Type	Anzahl/Qty.
Einstellbare Lenksäule / Adjustable Steering				
E432AH/BN1	Hupenknopf	horn button	BN1>149929LHD, BN1>149929RHD	1
E432AH	Hupenknopf	horn button	BN4-BJ8	1
E437AH/BN1	Hupenknopf/Blinkerschalter	horn push/trafficator	BN1>149929LHD, BN1>149929RHD	1
E437AH	Hupenknopf/Blinkerschalter	horn push/trafficator	BN4-BJ8	1
E439AH	Chromhebel Blinkerschalter	chrome lever trafficator	BN4-BJ8	1
E439aAH	Hebel Blinkerschalter „schwarz“	lever trafficator switch „black“	BN1	1
E445AH	Führungsrohr Kabel für einstellbare Lenksäule	stator tube adjustable	BN1-BJ8	1
L1AH	Original Lenkrad	original steering wheel	BN1-BJ8	1
L4AH	Staubmanschette	dust cover	BN1-BJ8	1
L50AH	Halter Staubmanschette unten	support, dust cover	BN1-BJ8	1
L51AH	Halter Staubmanschette oben	cup, dust cover	BN1-BJ8	1
L53AH	Sicherungsscheibe	ring, spring	BN1-BJ8	1
Nicht einstellbare Lenksäule / Non-Adjustable Steering				
E433AH/BN1	Hupenknopf	horn button	BN1<149930LHD, BN1<149930RHD, BN2	1
E433AH	Hupenknopf	horn button	BN4-BJ8	1
E438AH/BN1	Hupenknopf/Blinkerschalter *	horn push/trafficator *	BN1<149930LHD, BN1<149930RHD, BN2	1
E438AH	Hupenknopf/Blinkerschalter	horn push/trafficator	BN4-BJ8	1
E439aAH	Hebel Blinkerschalter „schwarz“	lever trafficator switch „black“	BN1<149930LHD, BN1<149930RHD, BN2	1
E439bAH	Chromhebel Blinkerschalter	chrome lever trafficator	BN4-BJ8	1
E446AH	Führungsrohr Kabel für nicht einstellbare Lenksäule	stator tube non adjustable	BN1>149950-BJ8	1
L2AH	Original Lenkrad, Ø 16,5"	original steering wheel, Ø 16.5"	BN1-BJ8	1
L3AH	Mutter Lenkradbefestigung	nut steering wheel	BN1-BJ8	1
L5AH	Blinker-Rückholarm	cancelling arm	BN1-BJ8	1

* Bitte nutzen Sie für den nicht mehr lieferbaren Hupenknopf/Blinkerschalter E438AH/BN1 den späten Hupenknopf/Blinkerschalter BN4-BJ8 (Art.Nr. E438AH) - Anpassungsarbeiten sind erforderlich

* Please note: the horn push/trafficator unit no. E438AH/BN1 is no longer available, please use the late unit (BN4-BJ8 - part no. E438AH) modifications required

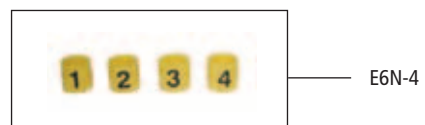
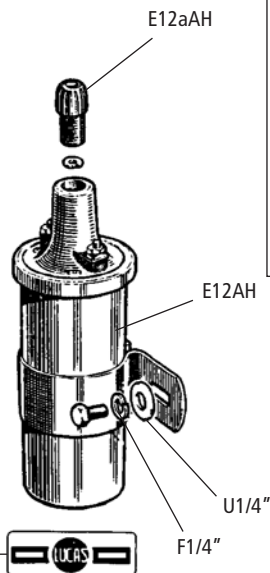
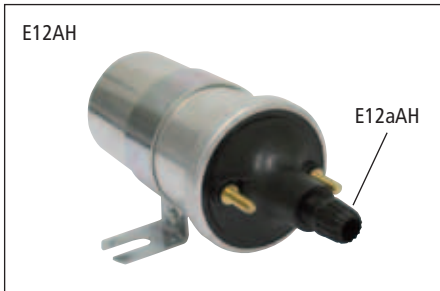
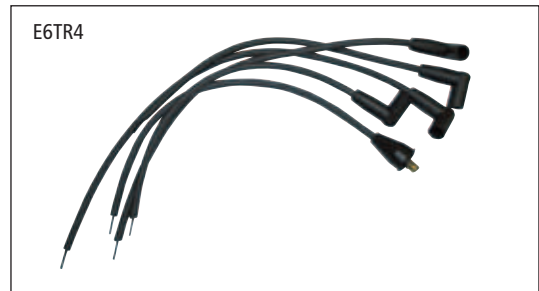
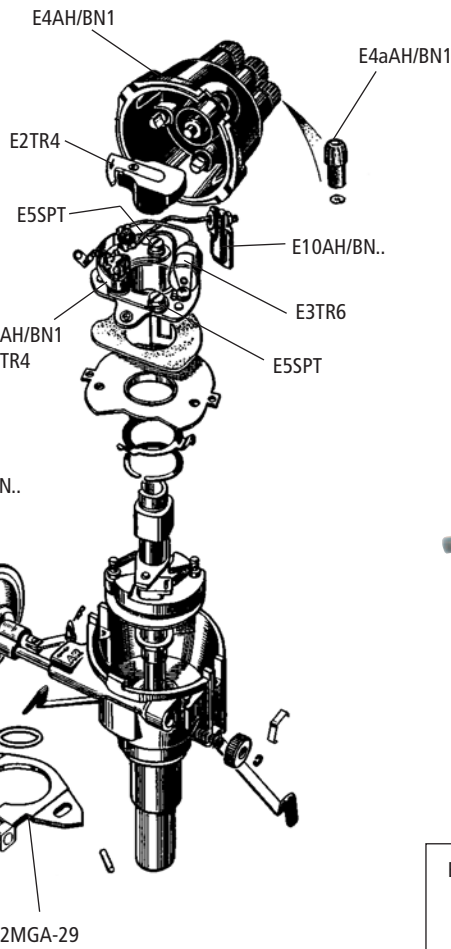
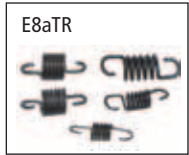

No.	Bezeichnung	Description	Type	Anzahl/Qty.
E1AH/BN1	Unterbrecherkontakt für E8AH/BN1 (Lucas Verteiler No. 40320/40422)	Point set for E8AH/BN1 (Lucas distributor no. 40320/40422)	BN1, BN2 bis 230360	1
E1TR4	Unterbrecherkontakt für E8AH/BN2(-M) (Lucas Verteiler No. 40495/40520)	Point set for E8AH/BN2(-M) (Lucas distributor no. 40495/40520)	BN2 ab 230361	1
E2TR4	Verteilerfinger	Rotor	BN1-BN2	1
E3TR6	Kondensator	Condenser	BN1-BN2	1
E4AH/BN1	Verteilerkappe original für geschraubte Zündkabel	Original distributor cap, screwed ignition wires	BN1-BN2	1
E4H	Verteilerkappe alternativ für gesteckte Zündkabel	Optional distributor cap, plugged ignition wires	BN1-BN2	1
E4aAH/BN1	Mutter für Verteilerkappe E4AH/BN1, separat	Nut, distributor cap	BN1-BN2	5
E5SPT	Befestigungsschraube Unterbrecherkontakt/ Kondensator	Screw for point set/condenser	BN1-BN2	2
E6TR4	Zündkabelsatz	Ignition wires, set	BN1-BN2	1
E6SPT	Zündkabelsatz bei Verwendung von Verteiler- kappe E4H	Ignition wires, set (if distributor cap E4H mounted)	BN1-BN2	1
E6N-4	Zündkabel Nummersatz (4-Zylinder)	Sleeve set, lead identification (4-cyl.)	BN1-BN2	1
E8AH/BN1	AT-Zündverteiler BN1, BN2 bis 230360	Distributor, exchange BN1, BN2 upto 230360	BN1-BN2	1
E8AH/BN2	AT-Zündverteiler BN1, BN2 ab 230361	Distributor, exchange BN1, BN2 from 230361	BN2	1
E8AH/BN2-M	AT-Zündverteiler 100 Le Mans	Distributor, exchange 100 Le Mans	BN1-BN2	1
E8aTR	Satz Verteilerfedern	Spring set	BN1-BN2	1
E9AH/BN1	Unterdruckdose	Vacuum unit	BN1-BN2	1
E9AH/BN2-M	Unterdruckdose für E8AH/BN2-M	Vacuum unit to no. E8AH/BN2-M	BN1-BN2	1
E10AH/BN1	Plastikanschluß Verteiler für geschraubtes Kabel	Low tension, lead and bush (screwed ignition wires)	BN1-BN2	1
E10AH/BN1-G	Plastikanschluß Verteiler für gestecktes Kabel	Low tension, lead and bush (plugged ignition wires)	BN1-BN2	1
E12AH	Zündspule „geschraubter“ Anschluß	Coil, ignition (screw in)	BN1-BN2	1
E12aAH	Mutter für E12AH	Nut for E12AH	BN1-BN2	1
E12SPTMK3	Zündspule gesteckter Anschluß als Alternative zu E12AH	Coin, ignition (plug in type) - optional to E12AH	BN1-BN2	1
E12MGA-29	Halteklammer Zündverteiler	Mounting plate ignition coil	BN1-BN2	1
E12aSPT	Aufkleber „Lucas“ für Zündspule	Lucas decal	BN1-BN2	1
E13MG/TF	Zündkerze	Spark plug	BN1-BN2	4
E13AH/BN2-M	Zündkerze 100 Le Mans	Spark plug 100 Le mans	BN1-BN2	4
E16MGB-23	Unterdruckleitung mit Schraubanschluß	Vacuum pipe, screwed	BN1-BN2	1
E41MGA-30	Zündkerzenstecker „Lucas“ Bakelit	Cap, spark plug	BN1-BN2	4

BN4, BN6, BN7, BT7, BJ7 < 29F-H3562

BJ7 > 29F-H3563, BJ8

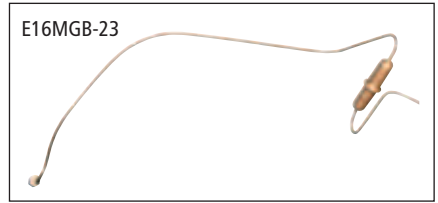
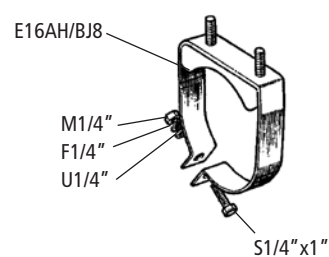
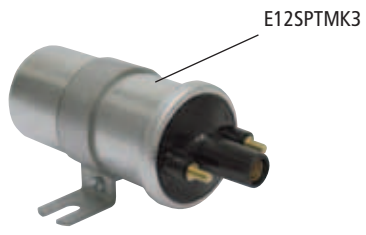
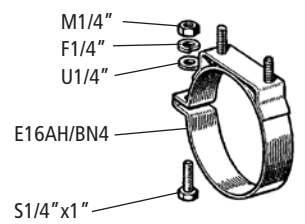
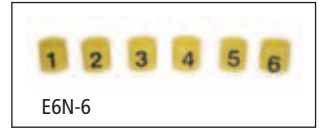
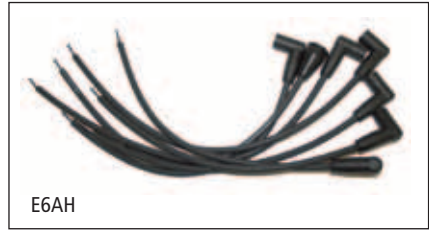
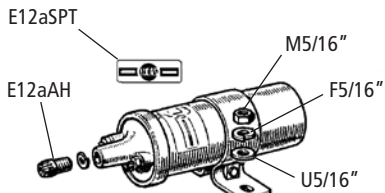
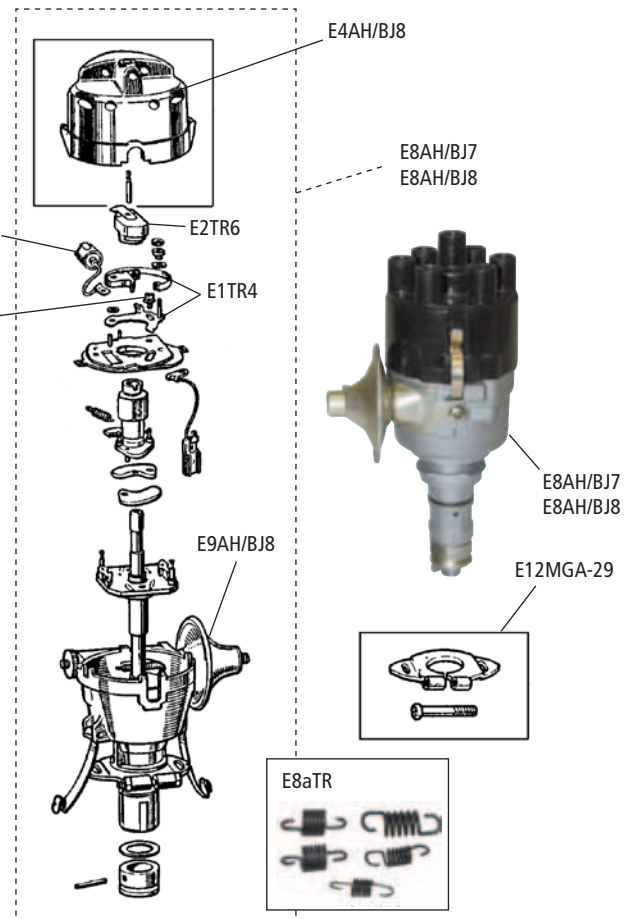
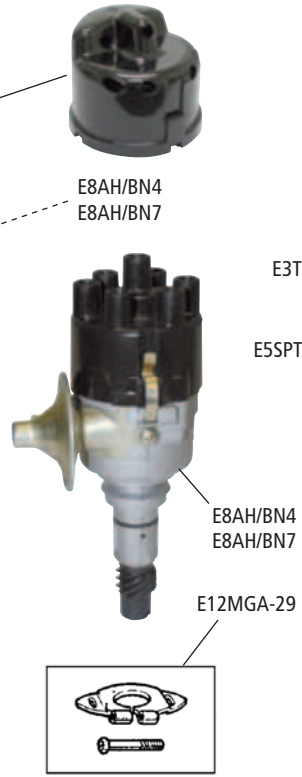
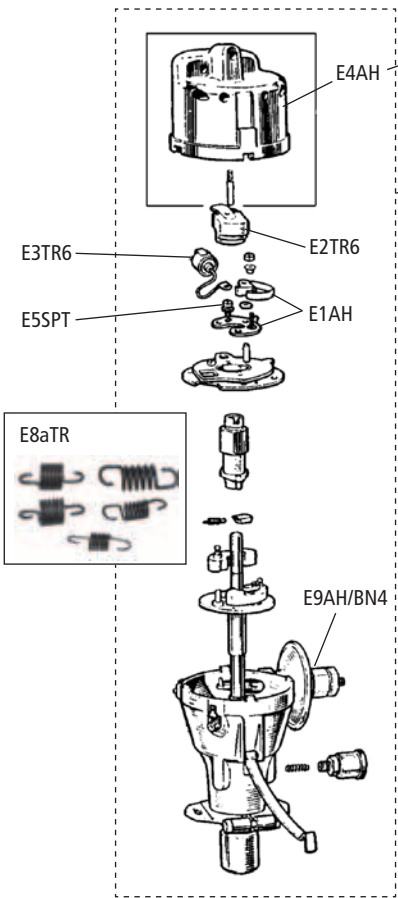

No.	Bezeichnung	Description	Type	Anzahl/Qty.
Verteiler / Distributor BN4, BN6, BN7, BT7, BJ7 < 29F-H3562				
E1AH	Unterbrecherkontakt	Point set	BN4-BJ7 bis 29FH3562	1
E2TR6	Verteilerfinger	Rotor	BN4-BJ8	1
E3TR6	Kondensator	Condenser	BN4-BJ8	1
E4AH	Verteilerkappe	Cap, distributor	BN4-BJ8	1
E5SPT	Befestigungsschraube Unterbrecherkontakt/ Kondensator	Screw for point set/condenser	BN4-BJ8	1
E8AH/BN4	Zündverteiler *)	Distributor *)	BN4/BN6	1
E8AH/BN7	Zündverteiler *)	Distributor *)	BN7,BT7,BJ7 bis 29F3562	1
E8aTR	Satz Verteilerfedern	Spring set	BN4-BJ8	1
E9AH/BN4	Unterdruckdose	Vacuum unit	BN4-BJ7 bis 29FH3562	1
E12MGA-29	Halteklammer Zündverteiler	Mounting plate ignition coil	BN4-BJ8	1
E16MGB-23	Unterdruckleitung mit Schraubanschlüssen	Vacuum pipe, screwed	BN4-BJ7 bis 29FH3562	1

Verteiler / Distributor BJ7 > 29F-H3563, BJ8

E1TR4	Unterbrecherkontakt	Point set	BJ7 ab 29FH3563	1
E2TR6	Verteilerfinger	Rotor	BJ7 ab 29FH3563	1
E3TR6	Kondensator	Condenser	BJ7 ab 29FH3563	1
E4AH/BJ8	Verteilerkappe	Cap, distributor	BJ7 ab 29FH3563	1
E5SPT	Befestigungsschraube Unterbrecherkontakt/ Kondensator	Screw for point set/condenser	BJ7 ab 29FH3563	1
E8AH/BJ7	Zündverteiler *)	Distributor *)	BJ7 ab 29FH3563	1
E8AH/BJ8	Zündverteiler *)	Distributor *)	BJ8	1
E8aTR	Satz Verteilerfedern	Spring set	BJ7 ab 29FH3563	1
E9AH/BJ8	Unterdruckdose	Vacuum unit	BJ7 ab 29FH3563	1
E9TR6	Plastikanschluß Verteiler	Low tension, lead and bush	BJ7 ab 29FH3563	1
E12MGA-29	Halteklammer Zündverteiler	Mounting plate ignition coil	BJ7 ab 29FH3563	1
E17AH	Unterdruckleitung	Vacuum pipe	BJ7 ab 29FH3563	1
E17	Unterdruckleitung 1,5 m 2 x Anschlussgummis	Vacuum pipe 1.5 m 2x rubber connection	BJ8	1
E31MGA-29	Gummiverbinder Unterdruckleitung	Connection, distributor end, rubber	BJ8	1

Verschleißteile für neue Verteiler 45D6 / Wearing parts for new distributor 45D6

(als Ersatz für DM6 u. 25D6 Verteiler)

(replacing distributor type DM6 and 25D6)

E4TR2000	Verteilerkappe	Cap, distributor
E2TR6	Verteilerfinger	Rotor
E1SPT1500	Unterbrecherkontakt	Point set
E3SPT1500	Kondensator	Condenser
E8ATR	Satz Verteilerfedern	Spring set

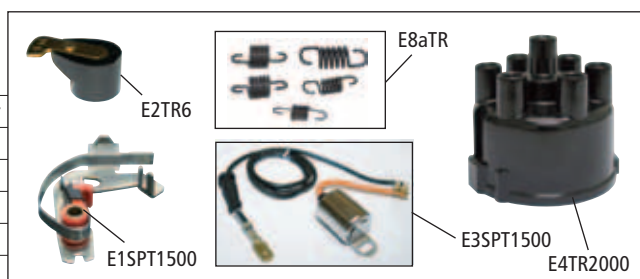
**Zündkabel, Zündspule, Zündkerzen****Ignition wires & coil, spark plug**

E6AH	Zündkabel Satz	Ignition wires, set	BN4-BJ8	1
E6N-6	Zündkabel Nummernsatz (6 Zyl.)	Sleeve set, lead identification (6-Cyl.)	BN4-BJ8	1
E12AH	Zündspule geschraubter Anschluss	Coil, ignition (screw in)	BN4-BJ8	1
E12aAH	Mutter separat für E12AH	Nut for E12AH	BN4-BJ8	1
E12SPTMK3	Zündspule gesteckter Anschluss (als Alternative für E12AH)	Coin, ignition (plug in type) - optional to E12AH	BN4-BJ8	1
E12aSPT	Aufkleber „Lucas“ für Zündspule	Lucas decal	BN4-BJ8	1
E13SPTMK4	Zündkerze	Spark plug	BN4-BJ8	6
E41MGA-30	Zündkerzenstecker „Lucas“ Bakelit	Cap, spark plug Lucas style	BN4-BJ8	6
E15AH/BN4	Auflageplatte für Zündspule	Plate, steady, coil	BN4,BN6,BN7,BT7	1
E16AH/BJ8	Halteklammer für Zündspule an Lichtmaschine	Bracket, coil to generator	BJ8	1
E16AH/BN4	Halteklammer für Zündspule an Lichtmaschine	Bracket, coil to generator	BN4,BN6,BN7,BT7	1

*) Verteilergehäuse 45D6 ersetzt
Gehäuse für Verteiler DM6 und 25D6

* (Housing distributor type 45D6 replaces
housing for type DM6 and 25D6)

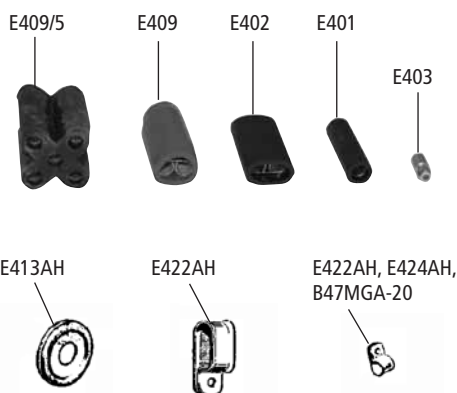
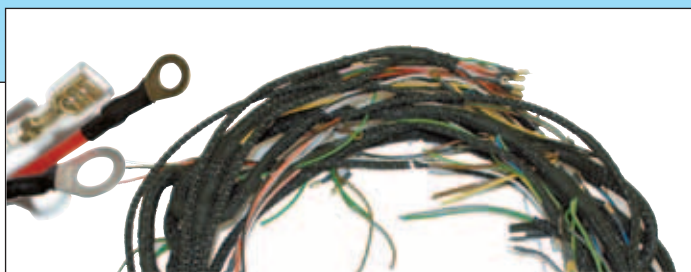

No.	Bezeichnung	Description	Type	Anzahl/Qty.
E400aAH/BJ8	Kabelbaum umwebt (Phase 2)	wiring loom cotton (phase 2)	BJ8>76138	1
E400AH/BJ8	Kabelbaum umwebt (Phase 1)	wiring loom cotton (phase 1)	BJ8<76137	1
E400AH/BN6	Kabelbaum umwebt	wiring loom cotton	BN7-BT7-BJ7	1
E400AH/BN4	Kabelbaum umwebt	wiring loom cotton	BN4/BN6	1
E400AH/BN2	Kabelbaum umwebt	wiring loom cotton	BN2	1
E400AH/BN1	Kabelbaum umwebt	wiring loom cotton	BN1	1
E400aTR3	Kabelbaum Lenkung	wiring harness steering column	BN1-BJ8	1
E414AH	Kabelbaum Overdrive umwebt	wiring loom overdrive cotton	BJ8	1
E415AH	Kabelbaum Overdrive umwebt	wiring loom overdrive cotton	BN2-BJ7	1
E416AH	Kabelbaum Overdrive umwebt	wiring loom overdrive cotton	BN1	1
E401	Kabelverbinder 1-fach	cable connector 1-way	BN1-BJ8	A/R
E402	Kabelverbinder 2-fach	cable connector 2-way	BN1-BJ8	A/R
E403	Kabelendstück (zum Anlöten)	brass wire tip	BN1-BJ8	A/R
E409	Kabelverbinder 3-fach	cable connector 3-way	BN1-BJ8	A/R
E409/5	Kabelverbinder 5-fach	cable connector 5-way	BN1-BJ8	A/R
E40AH	Relais Zündung/Hupe/Overdrive	horn relay	BN1-BN7	1
E40MGB	Hupenrelais - als günstige Alternative zu E40AH	horn relay - more favourable alternative to no. E40AH	BN1-BJ8	1
B47MGA-20	Kabelbefestigungsclip „klein“	wiring harness clip „small“	BN1-BJ8	10
E413AH	Kabeltülle Hauptstrang (In Spritzwand)	wiring grommet main harness (bulkhead)	BN1-BJ8	A/R
E422AH	Kabelbefestigungsclip „groß“	wiring harness clip „large“	BN1-BJ8	10
E424AH	Kabelbefestigungsclip „mittel“	wiring harness clip „medium“	BN1-BJ8	10
E432AH	Hupenknopf	horn button	BN4-BJ8	1
E435SPT	Universal-Hupe (Hoch- und Tieftön)	universal horn (high and low note)	BN1-BJ8	1
E437AH	Hupenknopf/Blinkerschalter	horn button/trafficator	BN4-BJ8	1
E439AH	Chromhebel Blinkerschalter	lever trafficator, chrome	BN4-BJ8	1

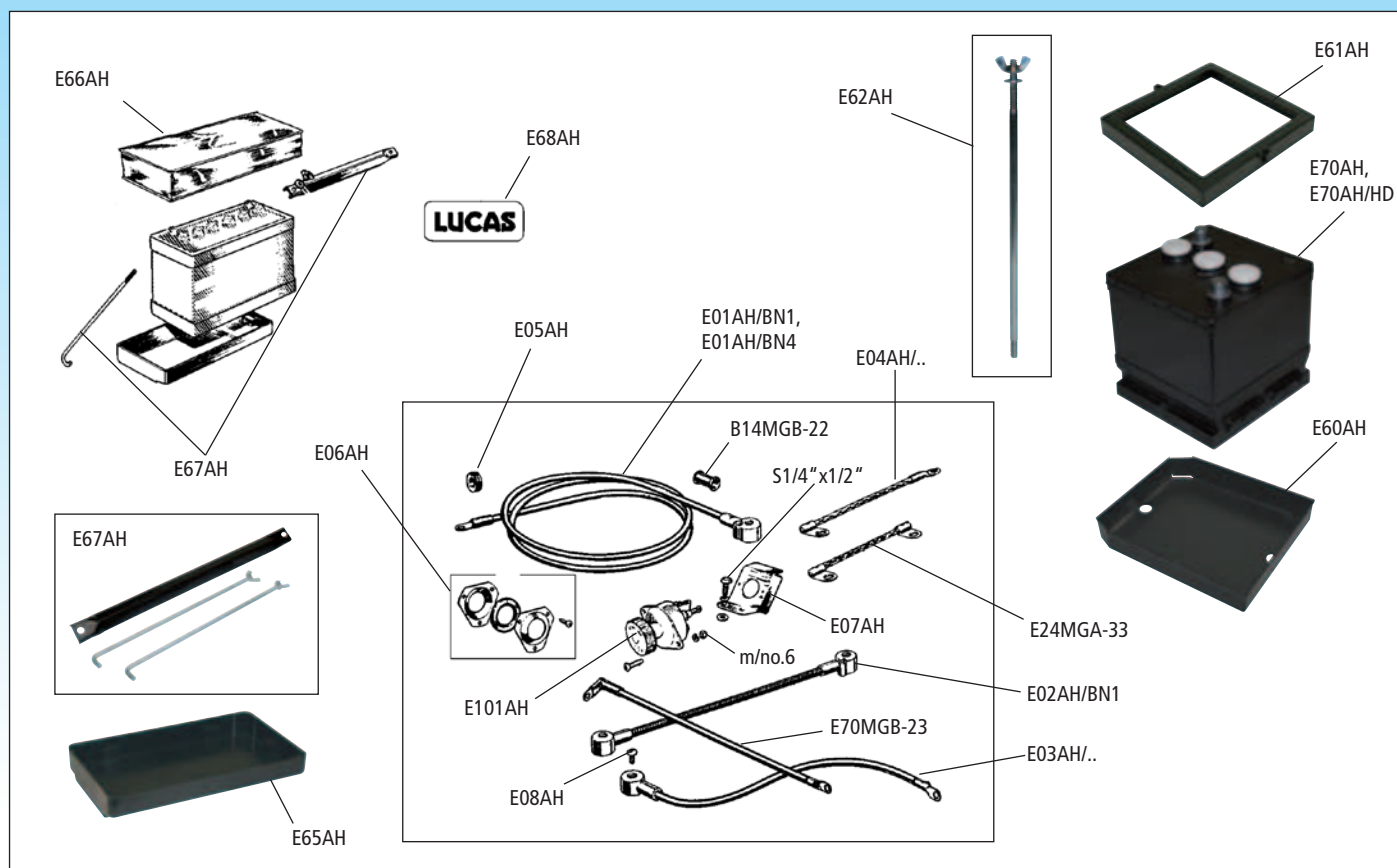

No.	Bezeichnung	Description	Type	Anzahl/Qty.
-----	-------------	-------------	------	-------------

Batterie / Battery BN4, BT7, BJ7, BJ8 – 12 Volt

E66AH	Batterie-Abdeckung 12V	cover, battery 12-volt	BN4,BT7,BJ7,BJ8	1
E67AH	Batterie-Halteset 12V	battery fixing set	BN4,BT7,BJ7,BJ8	1
E68AH	„LUCAS“ Batterie Aufkleber	battery decal, Lucas	BN4,BT7,BJ7,BJ8	A/R
E65AH	Batterie-Unterlagwanne 12V	tray, battery	BN4,BT7,BJ7,BJ8	1

Batterie / Battery BN1, BN2, BN6, BN7 – 6 Volt

E61AH	Batterie-Halterahmen 6V	bracket, battery 6-volt	BN1,BN2,BN6,BN7	2
E70AH	Batterie trocken 6V	battery 6-volt, dry charged	BN1,BN2,BN6,BN7	2
E70AH/HD	Batterie trocken Hochleistungsbatterie	battery, 6-volt, high performance, dry charged	BN1,BN2,BN6,BN7	2
E60AH	Batterie-Unterlagwanne 6V	tray, battery 6-volt	BN1,BN2,BN6,BN7	2
E62AH	Batterie-Halterstange+Mutter	rod, battery fixing	BN1,BN2,BN6,BN7	4

Batterie Kabel / Battery Cables & Fittings BN1-BJ8

E01AH/BN1	Batterie-Anschluss Minuspol	cabl e, battery negative to solenoid	BN1, BN2, BN6, BN7	1
E01AH/BN4	Batterie-Anschluss Minuspol	cabl e, battery negative to solenoid	BN4, BT7, BJ7, BJ8	1
E02AH/BN1	Kabel Batterieanschluss	cabl e, battery link	BN1, BN2, BN6, BN7	1
E03AH/BN1	Batterie-Anschluss Pluspol zu Batterie Hauptschalter	cabl e, battery positive to master switch	BN1, BN2	1
E03AH/BN4	Batterie-Anschluss Pluspol zu Batterie Hauptschalter	cabl e, battery positive to master switch	BN4, BT7, BJ7, BJ8	1
E03AH/BN6	Batterie-Anschluss Pluspol zu Batterie Hauptschalter	cabl e, battery positive to master switch	BN6, BN7	1
E04AH/BN1	Kabel Hauptschalter/Erde	cabl e, battery master switch to ground	BN1, BN2	1
E04AH/BN4	Kabel Hauptschalter/Erde	cabl e, battery master switch to ground	BN4, BN6, BN7, BT7, BJ7, BJ8	1
E05AH	Gummi-Dichtung	grommet, battery negative cable	BN4, BT7<15861	1
m/no.6	Mutter No.6	nut no.6	BN1-BJ8	2
E06AH	Halteset	retaining cap + grommet cable	BT7>15861, BJ7, BJ8	1
E07AH	Halter Batterie Hauptschalter	bracket, battery master switch	BN4, BT7, BJ7, BJ8	1
E08AH	Schraube Batteriekabel	screw, for cap type terminals	BN1-BJ8	2/4
B14MGB-22	Kabeldurchführung	sleeve, cable (rubber)	BN7>15862	1
E24MGA-33	Erdungskabel Motor/Getriebe an Chassis	cabl e, engine ground	BN1-BJ8	1
E70MGB-23	Kabel Magnetschalter an Anlasser	cabl e, solenoid to starter	BN1-BJ8	1
E101AH	Hauptschalter Batterie	switch, battery master	BN1-BJ8	1

Anlasser / Starter BN1-BJ8



Lichtmaschine und Befestigung / Alternator and mounting externals

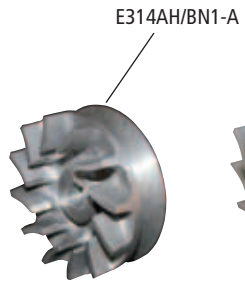

E311AH/BN1

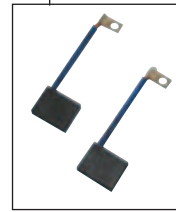

E311AH/BN7



E311AH/BJ8

Befestigungsteile Lichtmaschine / Mounting externals for alternator

BN1-BN2

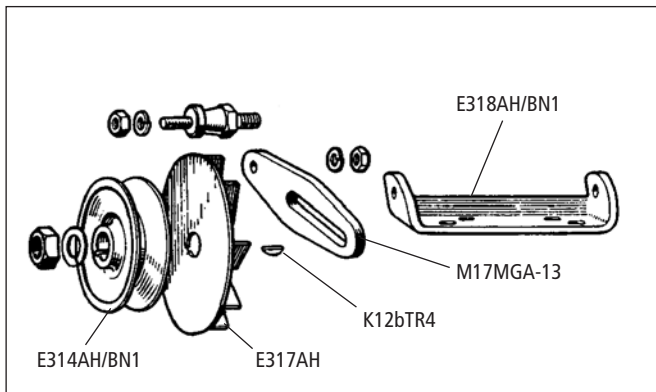

BN4-BJ8

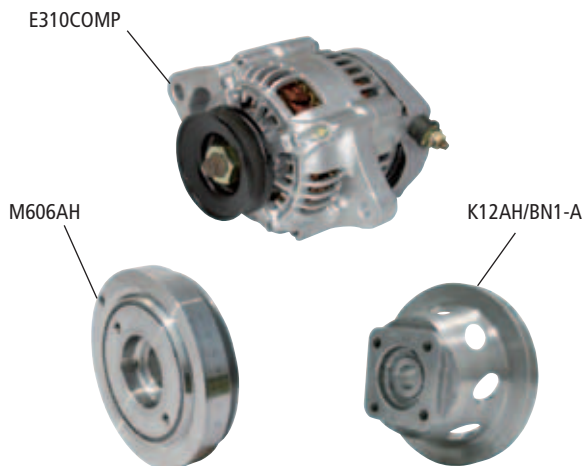
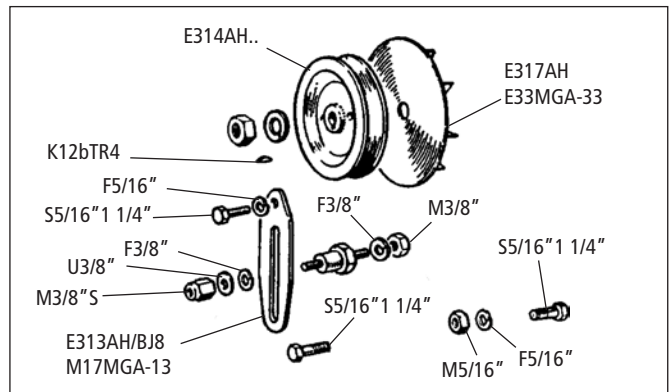

E310BRKT/AH-4

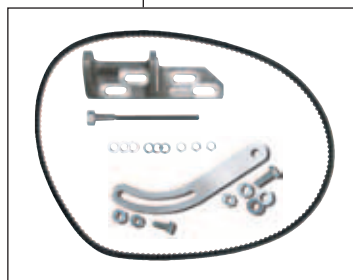

E310BRKT/AH-6

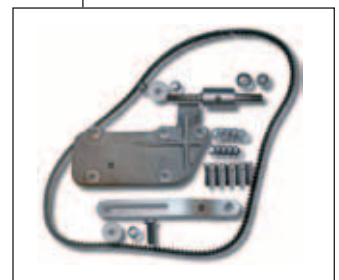

No.	Bezeichnung	Description	Type	Anzahl/Qty.
Anlasser / Starter (BN1-BJ8)				
E300AH	AT-Anlasser	Starter, exchange	BN1-BJ8	1
E300AHRACE	Hochleistungs-Getriebeanlasser als Ersatz für den etwas leistungsschwachen original Anlasser	High performance starter motor replaces the „inefficient“ original starter	BN1-BJ8	1
E303TR4	Satz Kohlen für Anlasser E300AH	Brush set to starter E300AH	BN1-BJ8	2
Lichtmaschinen und Befestigungen / Alternators and mounting externals				
E310AH	AT-Lichtmaschine	Alternator, exchange	BN1-BJ7	1
E310AH/BJ8	AT-Lichtmaschine	Alternator, exchange	BJ8	1
E311AH/BN1	Satz Kohlen Lichtmaschine für Lucas Lima Type 22456AD/22483AD	Brush set alternator Lucas Type 22456AD/22483AD	BN1,BN2,BN4,BN6	1
E311AH/BN7	Satz Kohlen Lichtmaschine für Lucas Lima Type 22489B-E / 22519A / 22530A-B	Brush set alternator Lucas Type 22489B-E / 22519A / 22530A-B	BN7,BT7,BJ7	1
E311AH/BJ8	Satz Kohlen Lichtmaschine für Lucas Lima Type 22900A-J	Brush set alternator Lucas Type 22900A-J	BJ8	1
K12AH/BN1-A	Alu-Riemenscheibe Wasserpumpe* für schmalen Keilriemen	Water pump pulley alloy* for small V-belt	BN1-BN2	1
E310COMP	Hochleistungs-Lichtmaschine Drehstrom für 10 oder 12 mm Keilriemen	High performance AC alternator for 10 or 12 mm V-belt	BN1-BJ8	1
E310BRKT/AH-4	Haltesatz für Hochleistungs-Lichtmaschine	Mounting kit for high performance AC alternator	BN1-BN2	1
E310BRKT/AH-6	Haltesatz für Hochleistungs-Lichtmaschine	Mounting kit for high performance AC alternator	BN4-BJ8	1
M606AH	Keilriemenscheibe Kurbelwelle* mit Hochleistungs-Schwingungsdämpfer	Crankshaft pulley * with high performance vibration damper	BN1-BJ8	1

* K12AH/BN1-A und M606AH werden zur Montage der Lichtmaschine E310COMP bei Austin Healey 100/4, BN1-BN2 Modellen zusätzlich benötigt
Ausführliche Montageanleitungen sind den Haltesätzen beigefügt bzw. auch im Internet zu finden.

* Part no. K12AH/BN1-A and no. M606AH will be required to mount the alternator E310COMP to Austin Healey models 100/4, BN1-BN2
The mounting kits coming with detailed fitting instructions. Instructions also available online.

Befestigungsteile Lichtmaschine / Mounting externals for alternator BN1-BN2

K12bTR4	Keil	Pin	BN1-BN2	1
M17MGA-13	Spanner	Adjusting link	BN1-BN2	1
E314AH/BN1	Riemenscheibe	Pulley	BN1-BN2	1
E314AH/BN1-A	Aluminium Riemenscheibe alternativ	Alloy pulley, alternative	BN1-BN2	1
E317AH	Lüfterrad	Fan	BN1-BN2	1
E318AH/BN1	Halter am Motorblock	Bracket to bloc	BN1-BN2	1

Befestigungsteile Lichtmaschine / Mounting externals for alternator BN4-BJ8

K12bTR4	Keil	Pin	BN4-BJ8	1
M17MGA-13	Spanner	Adjusting link	BN4-BJ8 bis 29K-H10271	1
E33MGA-33	Lüfterrad für Aufnahmewelle Ø15	Fan, Ø 15 shaft	BN4-BJ8	1
E313AH/BJ8	Spanner	Adjusting link	BJ8 ab 29K-H10272	1
E314AH-A	Alu-Riemenscheibe für Aufnahmewelle Ø 17 *)	Alloy pulley, Ø 17 shaft *)	BN4-BJ8	1
E314AH/BJ8-A	Alu-Riemenscheibe für Aufnahmewelle Ø 15 *)	Alloy pulley, Ø 15 shaft *)	BJ8	1
E317AH	Lüfterrad für Aufnahmewelle Ø 17	Fan, Ø 17 shaft	BN4-BJ8	1

*) Hochwertiger Ersatz der nicht mehr lieferbaren original Riemenscheibe. Mit extra tiefem „V“ Einschnitt gegen Abspringen des Keilriemens (passend für 10 und 12 mm Keilriemen)

*) High quality alternative to the n.i.a. original pulley (for 10 or 12 mm V-belts)

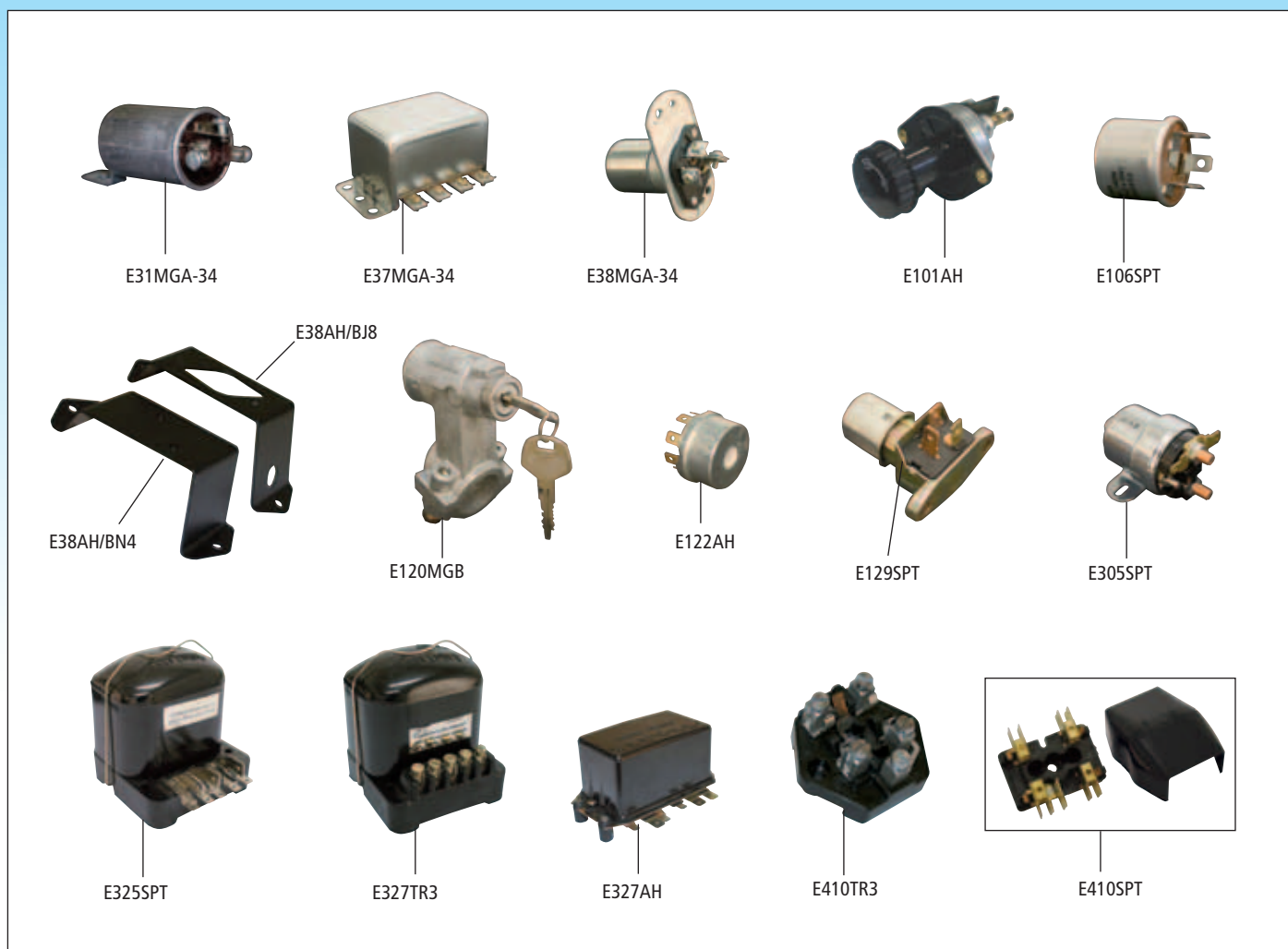

No.	Bezeichnung	Description	Type	Anzahl/Qty.
Relais, Regler, Sicherungskästen.. / Relais, Regulator, Fuse-boxes..				
E31MGA-34	Blinkerrelais geschraubte Anschlüsse	flasher relais (screwed-on)	BN1-BJ7	1
E37MGA-34	Blinker/Bremslicht Trennrelais	relais flasher/stoptlight	BN1-BJ8<76137	1
E38MGA-34	Fern/Abblendlichtschalter (Schraubanschlüsse)	switch, headlamp dip (screwed-on)	BN1-BJ7	1
E38AH/BN4	Halterung Fern/Abblendlichtschalter	bracket dipper switch	BN4-BJ7	1
E38AH/BJ8	Halterung Fern/Abblendlichtschalter	bracket dipper switch	BJ8	1
E101AH	Hauptschalter Batterie	switch, battery master	BN1-BJ8	1
E106SPT	Blinkerrelais gesteckte Anschlüsse	flasher relais (plug-in)	BJ8	1
E120MGB	Zünd/Lenkradschloss (Sonderzubehör optional)	lock assembly, steering column (rare option)	BN7-BJ8	1
E122AH	Elektroteil zu E120MGB	switch ignition to no. E120MGB	BN7-BJ8	1
E129SPT	Fern/Abblendlichtschalter (Steckanschlüsse)	switch, headlamp dip (plug-in)	BJ8	1
E305SPT	Magnetschalter Anlasser	solenoid, starter	BN1-BJ8	1
E325SPT	Regler Lichtmaschine (Steckanschlüsse)	voltage regulator, plug-in	BN1-BJ7	1
E327TR3	Regler Lichtmaschine (Schraubanschlüsse)	voltage regulator, screwed-on	BN1-BJ7	1
E327AH	Regler Lichtmaschine	voltage regulator	BJ8	1
E410TR3	Sicherungskasten Schraubanschlüsse	fuse-box (screwed-on)	BN1-BJ7	1
E410SPT	Sicherungskasten Steckanschlüsse	fuse-box (plug-in)	BJ8	1
E415SPT10	Glassicherung 10 Ampère	fuse, 10 amp.	BJ8	A/R
E415SPT35	Glassicherung 35 Ampère	fuse, 35 amp.	BN1-BJ8	A/R
E415SPT50	Glassicherung 50 Ampère	fuse, 50 amp.	BN1-BJ8	A/R
E420SPT	„Fliegende“ Sicherung	fuse/holder (in-line)	BJ8	A/R



No.	Bezeichnung	Description	Type	Anzahl/Qty.
E460SPT	Schraubbirne Armaturenbrettbeleuchtung	bulb instrument panel	BN1-BJ8	A/R
E475ESPT	Öltemperaturinstrument elektrisch, mit Chromrand	oil temperature gauge, electrical with chrome ring	BN1-BJ8	1
E475MSPT	Öltemperaturinstrument mechanisch, mit Chromrand	oil temperature gauge, mechanical with chrome ring	BN1-BJ8	1
E475aSPT	Geber für Öltemperaturinstrument E475SPT oder Wassertemperaturinstrument E485SPT	transmitter oil temperature gauge (no. E475SPT) or water temperature no. E485SPT	BN1-BJ8	A/R
E475bSPT	Adapter zu E475SPT an Ölwanne oder zu E485SPT an Thermostatgehäuse	adaptor to no. E475SPT to oil sump or to E485SPT to thermostat housing	BN1-BJ8	A/R
E476SPT	Amperemeter mit Chromrand	amperemeter gauge, with chrome ring	BN1-BJ8	1
E477SPT	Voltmeter mit Chromrand	voltmeter gauge, with chrome ring	BN1-BJ8	1
E478SPT	Zeituhr mit Chromrand	clock, with chrome ring	BN1-BJ8	1
E480SPT	Doppelinstrument Wassertemperatur u. Öldruck	double instrument water temperature and oil pressure gauge	BJ8	1
E480bSPT	Adapter für E480SPT (Wasseranschluß)	adaptor for E480SPT (water connection)	BN1-BJ8	1
E481SPT	Öldruckinstrument mechanisch	oil pressure gauge, mechanical	BN1-BJ8	1
E485SPT	Wassertemperaturinstrument mechanisch	water temperature gauge, mechanical	BN1-BJ8	1
E490SPT/52	Chromrand für SMITH Instrumente Ø 52 mm	chrome ring for SMITH instruments Ø 52 mm	BN1-BJ8	A/R

- Neue Produktion – Qualitativ hochwertige Nachfertigungen der Zusatzinstrumente!
- New production – High quality re-designed instruments!



Doppelinstrument Öldruck/Wassertemperatur:		double instrument oil pressure/water temp.:	
E480AH/BN1-n	Ziffernblatt schwarz (Fahrenheit) -*	black face (Fahrenheit) -*	BN1, BN2 GD1500/29 1
E480AH/BN4-n	Ziffernblatt magnolia (Fahrenheit) -*	magnolia face (Fahrenheit) -*	BN4<68959, BN6<2029 GD1502/00 1
E480AH/BJ7-n	Ziffernblatt magnolia (°Celsius) -*	magnolia face (°Celsius) -*	BN7, BT7>14299, BJ7 1
E480SPT-c	Ziffernblatt schwarz (°Celsius)	black face - light inside (°Celsius)	BJ8 1
Benzinuhr:		fuel gauge:	
E482AH/BN1-n	Ziffernblatt schwarz -*	black face -*	BN1, BN2, 100M FG2530/19 1
E482AH/BN4-n	Ziffernblatt magnolia -*	magnolia face -*	BN4, BN6, BN7, BT7, BJ7 FG253030/03 1
E482AH/BJ8-n	Ziffernblatt schwarz	black face - light inside	BJ8 FG2333/10 1

-* von außen blau beleuchtet

-* blue light outer

Scheinwerfer / Headlamps BN1-BJ8



Blinker/Rückleuchte / Flasher/stop & tail light BN1-BN2



Rückstrahler / Reflector BN1-BN2

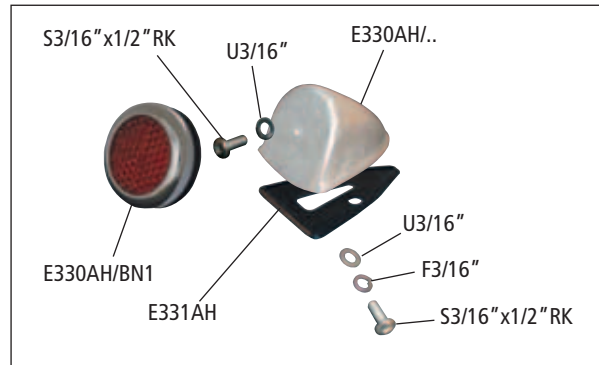

Kennzeichenleuchte / License plate lamp BN1-BJ8

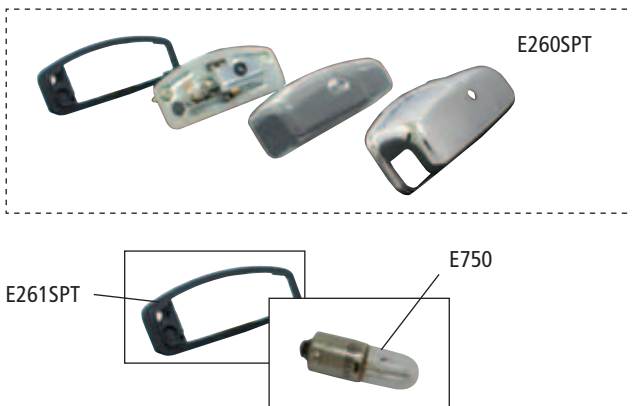

Zusatzscheinwerfer / Driving and Fog Lamps



No.	Bezeichnung	Description	Type	Anzahl/Qty.
Scheinwerfer / Headlamps BN1-BJ8				
E33MGA-30	Gummi unter Lampentopf	Rubber, front light housing/body	BN1-BJ8	2
E37MGA-30	Staubschutzgummi Scheinwerfer	Headlamp dust excluder	BN1-BJ8	2
E200TR	H4-Scheinwerfer mit Standlicht (Set incl. Birnen)	Reflector Halogen H4 with parking light insert (Set incl. bulbs)	BN1-BJ8	1
E200SPT	H4-Scheinwerfer ohne Standlicht (Set incl. Birnen)	Reflector Halogen H4 without parking light insert (Set incl. bulbs)	BN1-BJ8	1
E200A	Paar Steinschlagschutzgitter	Pair headlamp stoneguard	BN1-BJ8	1
E201TR6	Stecker mit Kabelstrang	adapter bulb „Europe“ with lead	BN1-BJ8	1
E203SPT	Einstellschrauben für 1 Scheinwerfer	headlamp screw trimmer set	BN1-BJ8	1
E202SPT	Lampentopf Plastik komplett	Front light housing (plastic), complete	BN1-BJ8	2
E202aSPT	Lampentopf Blech	Front light housing (metal)	BN1-BJ8	2
E204SPT	Lampenring chrom, außen	Chrome ring	BN1-BN2	2
E204AH	Lampenring chrom, außen	Chrome ring	BN4-BJ8	2
E700	H4-Glühbirne für E200SPT	Bulb, H4 to no. E200SPT	BN1-BJ8	2

Blinker, Rückleuchte / Flasher, Tale light (Lucas model 488) BN1-BN2

E223AH	Blinker, flaches Glas, klar	Flasher, plain lens, clear	BN1-BN2	2
E223AH/G	Blinker, flaches Glas, gelb	Flasher, plain lens, yellow	BN1-BN2	2
E223AH/R	Brems/Rückleuchte/Blinker hinten, flaches Glas, rot	Rear flasher/brake/tail light, plain lens, red	BN1-BN2	2
E225AH	Blinkerglas, flach, klar	Lens, plain, clear	BN1-BN2	2
E225AH/G	Blinkerglas, flach, gelb	Lens, plain, yellow	BN1-BN2	2
E225AH/R	Blinkerglas, flach, rot	Lens, plain, red	BN1-BN2	2
E232SPT	Chromring	Chrome ring	BN1-BN2	4
E233aSPT	Fassung 2-polig	Bulb holder, twin	BN1-BN2	4
E234aSPT	Gummigehäuse lang	Rubber boot, long	BN1-BN2	4
E711	Glühbirne 12V-21/5W	Bulb 12V-21/5W	BN1-BN2	4

Rückstrahler (wenn montiert) / Rear reflector (if mounted) BN1-BN2

E330AH/BN1	Rückstrahler	Reflector	BN1-BN2	2
E330AH/L	Sockel Rückstrahler links	Socket, reflector, lh	BN1-BN2	1
E330AH/R	Sockel Rückstrahler rechts	Socket, reflector, rh	BN1-BN2	1
E331AH	Gummi unter Sockel	Rubber socket/body	BN1-BN2	2
S3/16"x1/2"RK	Rundkopfschraube 3/16"x1/2"UNF	Round-head srew 3/16"x1/2"UNF	BN1-BN2	6

Kennzeichenleuchte / License plate lamp BN1-BJ8

E260SPT	Nummernschildleuchte	License plate lamp	BN1-BJ8	1
E261SPT	Dichtung unter Nummernschildleuchte	Seal, rubber	BN1-BJ8	1
E750	Glühbirne 12V 5W (Bajonett)	Bulb 12V 5W (bayonet)	BN1-BJ8	1-2

Zeitgenössisches Zubehör: Fern- und Nebelscheinwerfer / Period Style: Driving and Fog Lamps

No.	Bezeichnung	Description	Type	Anzahl/Qty.
E205	Zusatz Fernscheinwerfer (Befestigung unten)	High beam headlamp (stemmount)	BN1-BJ8	2
E205a	Zusatz Fernscheinwerfer (Befestigung hinten)	High beam headlamp (backmount)	BN1-BJ8	2
E206	Zusatz Nebelscheinwerfer (Befestigung unten)	Fog lamp (stemmount)	BN1-BJ8	2
E206a	Zusatz Nebelscheinwerfer (Befestigung hinten)	Fog lamp (backmount)	BN1-BJ8	2
E720	Glühbirne für Fernscheinwerfer	Bulb for high beam headlamp	BN1-BJ8	2
E721	Glühbirne für Nebelscheinwerfer (12V-48W)	Bulb for fog lamp (12V-48W)	BN1-BJ8	2

Blinker/Rückleuchte / Flasher/stop & tail light BN4, BN6, BN7, BT7, BJ7, BJ8 < 26704

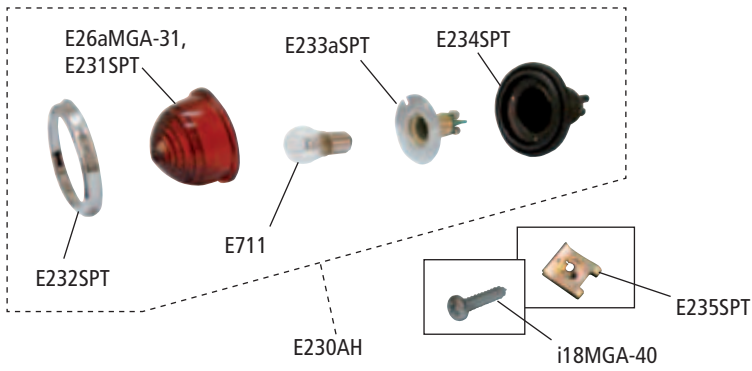

Rückstrahler 100-6, 3000 (alle Modelle) / Rear reflector 100-6, 3000 (all models)

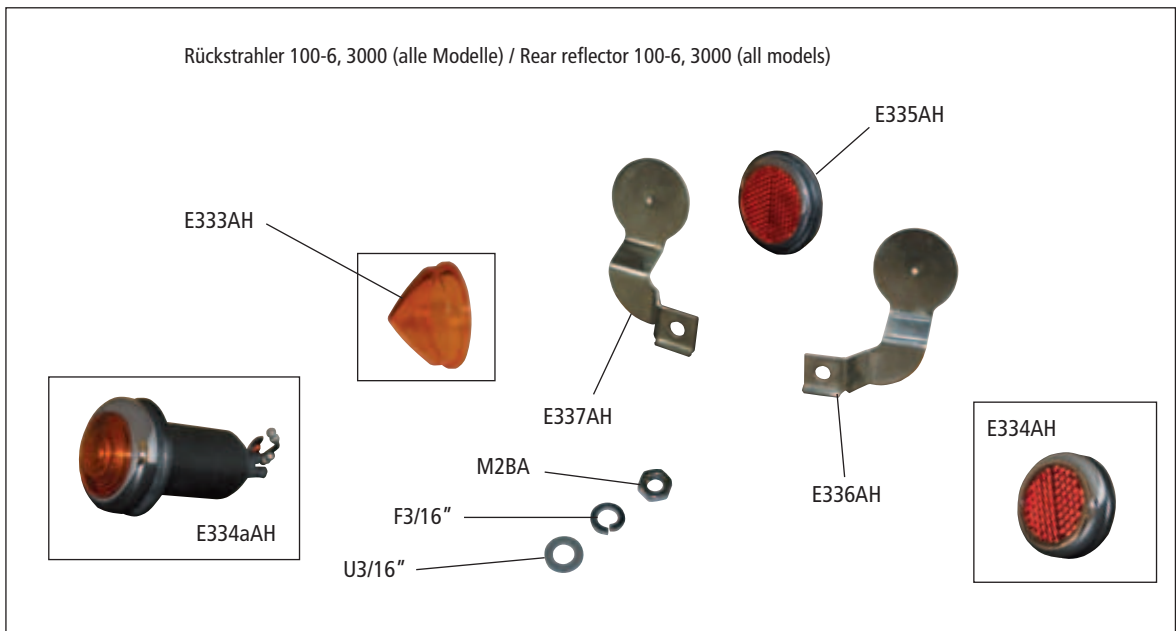

Blinker-Rückleuchte / Flasher-Tail lamp BJ8 > 26705

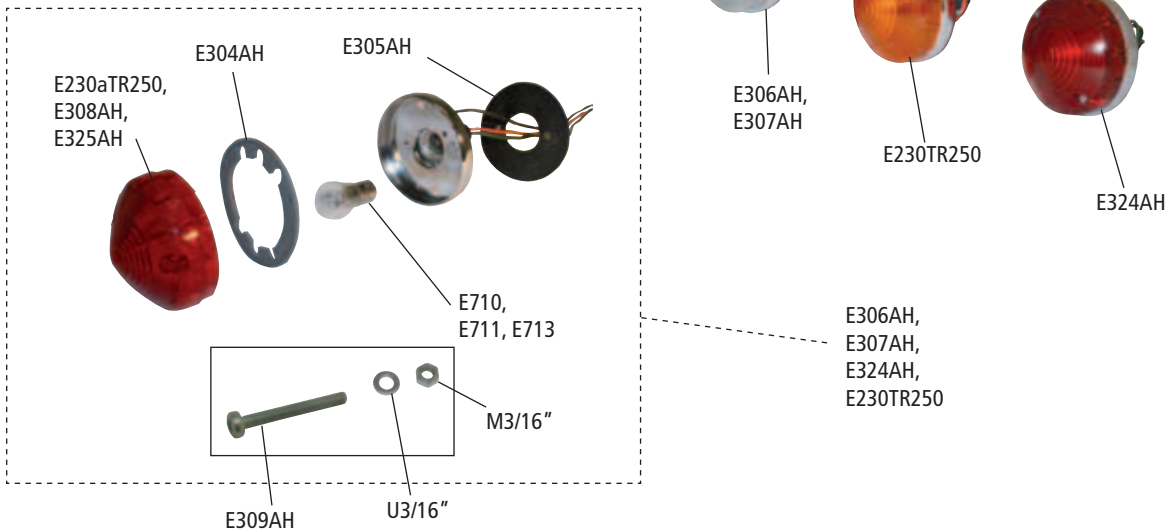

No.	Bezeichnung	Description	Type	Anzahl/Qty.
Blinker, Rückleuchte / Flasher, Tale light (Lucas model 594) BN4, BN6, BN7, BT7, BJ7, BJ8 < 26704				
i18MGA-40	Befestigungsschraube	screw		per Leuchte/lamp 3
E26aMGA-31	Blinker/Rückleuchtenglas, rot	lens, flasher/tail light, red	BN4-BJ8<26704	2
E230AH	Blinker/Standlicht vorne, klar	front flasher/parking light, clear	BN4-BJ8<26704	2
E230AH/R	Rückleuchte/Blinker hinten, rot	rear flasher/tail light, red	BN4-BJ8<26704	2
E231SPT	Blinkerglas, orange	lens, yellow	BN4-BJ8<26704	2
E231aSPT	Blinkerglas, weiß	lens, white	BN4-BJ8<26704	2
E232SPT	Chromring	chrome ring	BN4-BJ8<26704	4
E233aSPT	Fassung, 2-polig	bulb holder, twin	BN4-BJ8<26704	4
E234SPT	Gummigehäuse, kurz (ca. 70 mm lang)	rubber boot, short (ca. 70 mm)	BN4-BJ8<26704	4
E234aSPT	Gummigehäuse, lang (ca. 82 mm lang)	rubber boot, long (ca. 82 mm)	BN4-BJ8<26704	4
E235SPT	Blechmutter	plane nut		per Leuchte/lamp 3
E711	Glühbirne 12V-21/5W	bulb 12V-21/5W	BN4-BJ8<26704	4

Rückstrahler 100-6, 3000 (alle Modelle) / Rear reflector 100-6, 3000 (all models)

E333AH	Rückstrahler konisch (wenn vorhanden)	reflector conical (if fitted)	BN4, BN6	2
E333aAH	Glas Rückstrahler, konisch (wenn vorhanden)	lens reflector, conical (if fitted)	BN4, BN6	2
E334AH	Rückstrahler flach	reflector assembly, plane	BN6, BN7, BT7, BJ7, BJ8 < 76137	2
E334aAH	Blinkleuchte als Ersatz für Rückstrahler E334AH	direction indicator, replaces reflector E334AH	BN6, BN7, BT7, BJ7, BJ8 < 76137	2
E335AH	Rückstrahler angeschraubt	reflector assembly, screw fitting	BJ8 > 76138	2
E336AH	Halter für Rückstrahler rechts	bracket, reflector mounting, RH	BJ8 > 76138	1
E337AH	Halter für Rückstrahler links	bracket, reflector mounting, LH	BJ8 > 76138	1

Blinker-Rückleuchte / Flasher-Tail lamp BJ8 > 26705

Leuchte komplett / Lamp complete:

E230TR250	Blinkleuchte hinten + vorne, oranges Glas (21W)	flasher lamp rear + front, yellow lens (21W)	BJ8	4
E306AH	Park/Blinkleuchte vorne, weißes Glas (5/21W)	parking/flasher lamp front clear lens (5/21W)	BJ8 > 26705-76137	2
E307AH	Parkleuchte vorne, weißes Glas (5W)	parking lamp front, clear lens (5W)	BJ8 > 76138	2
E324AH	Brems/Rückleuchte, rotes Glas (5/21W)	stop/tail lamp, red lens (5/21W)	BJ8 > 26705	2

Einzelteile für Leuchten / Components:

E230aTR250	Blinkerglas, orange	flasher lens, yellow	BJ8 > 26705	2
E308AH	Standlichtglas, weiß	parking lens, clear	BJ8 > 26705	2
E325AH	Rückleuchtenglas, rot	rear light lens, red	BJ8 > 26705	2
E304AH	Dichtung Glas zu Leuchte	gasket, lens seating	BJ8 > 26705	2
E305AH	Dichtung Leuchte zu Karosserie	pad, lamp body seating	BJ8 > 26705	2
E309AH	Befestigungsschraube	screw, for lens	BJ8 > 26705	4
E710	Glühbirne 12V-21W	bulb, single filament 12V-21W, flasher lamp		
E711	Glühbirne 12V-21/5W	bulb, twin filament 12V-21/5W, stop/tail & flasher/side lamps		
E713	Glühbirne 12V-5W	bulb, single filament 12V-5W, side/parking lamp		

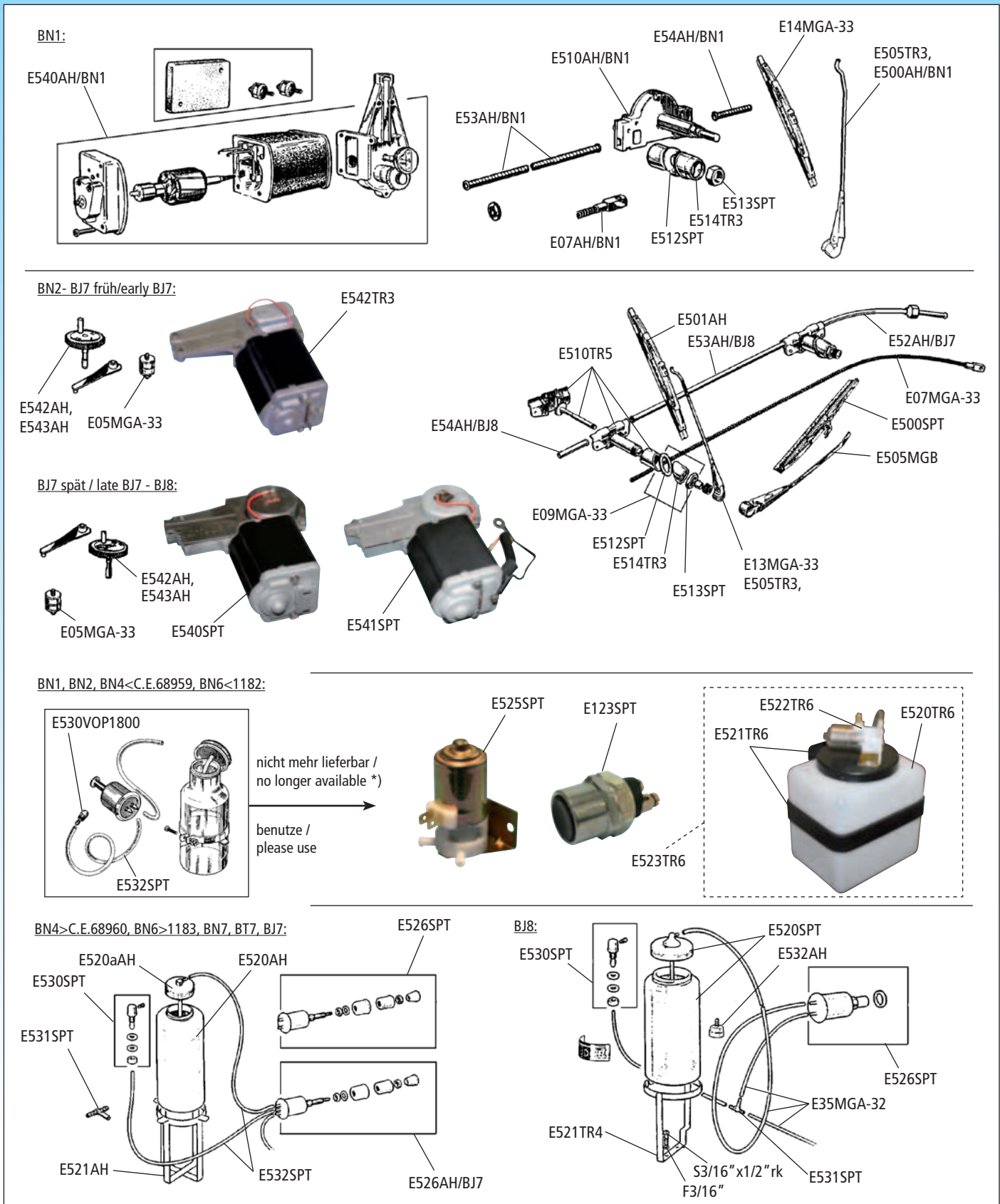

No.	Bezeichnung	Description	Type	Anzahl/Req.
Scheibenwischermotor / Wiper Motor BN1				
E07AH/BN1	Wischantriebswelle	crosshead and rack	BN1	1
E14MGA-33	Wischerblatt 8"	blade, wiper	BN1	1
E53AH/BN1	Hülle Wischantriebswelle Motor zu Wischerantrieb	casing, outer motor to wheelbox	BN1	1
E54AH/BN1	Hülle Wischantriebswelle Motor - Ende	casing, offside wheelbox	BN1	1

No.	Bezeichnung	Description	Type	Anzahl/Qty.
Scheibenwischermotor / Wiper Motor BN1				
E500AH/BN1	Wischerarm RHD	wiper arm RHD	BN1	2
E505TR3	Wischerarm LHD	wiper arm LHD	BN1	2
E510AH/BN1	Wischergetriebe	wheelbox	BN1	2
E512SPT	Gummi unter Wischerantrieb	washer, rubber	BN1	2
E513SPT	Chrommutter Wischerantrieb	nut, chrome	BN1	2
E514TR3	Distanzstück chrom	bezel, chrome	BN1	2
E540AH/BN1	AT-Scheibenwischermotor	wiper motor, exchange	BN1	1
Scheibenwischermotor / Wiper Motor BN2, BN4, BN6, BN7, BT7, BJ7, BJ8				
E05MGA-33	Befestigungssatz Wischermotor	mounting kit, wiper motor	BN2-BN7, BT7, BJ7, BJ8	1
E07MGA-33	Wischerantriebswelle 140cm	crosshead & rack	BN2-BJ8	1
E09MGA-33	Anbauteil Wischerarmtrieb	bezel kit	BN2-BJ8	1
E13MGA-33	Wischerarm RHD	wiper arm RHD	BN2-BT7	2
E53AH/BJ7	Hülle Wischerantriebswelle Motor zu Wischerarmtrieb	casing, outer motor to wheelbox	BN2-BJ7<60791	1
E53AH/BJ8	Hülle Wischerantriebswelle Motor zu Wischerarmtrieb	casing, outer motor to wheelbox	BJ7>60792, BJ8	1
E54AH/BJ8	Hülle Wischerantriebswelle Motor - Ende	casing, offside wheelbox	BN2, BN4, BN6, BN7, BT7, BJ7, BJ8	1
E500SPT	Wischerblatt 5mm Aufnahme	blade, wiper	BJ7-BJ8	2
E501AH	Wischerblatt 9" spoon type fitting	blade, wiper 9" spoon type fitting	BN2, BN4, BN6, BN7, BT7	2
E505TR3	Wischerarm LHD	wiper arm LHD	BN2, BN4, BN6, BN7, BT7	2
E505MGB	Wischerarm Edelstahl 5mm Aufnahme LHD	wiper arm, stainless steel LHD	BJ7-BJ8	2
E510TR5	Wischergetriebe	wheelbox	BN2-BJ8	2
E512SPT	Gummi unter Wischerantrieb	washer, rubber	BN2-BJ8	2
E513SPT	Chrommutter Wischerantrieb	nut, chrome	BN2, BN4, BN6, BN7, BT7, BJ7, BJ8	2
E514TR3	Distanzstück chrom	bezel, chrome	BN2, BN4, BN6, BN7, BT7, BJ7, BJ8	2
E540SPT	AT-Scheibenwischermotor einstufig „DR3“	wiper motor, 1 vitesse „DR3“	BJ7>60792-BJ8	1
E541SPT	AT-Scheibenwischermotor 2-stufig	wiper motor, 2 vitesse	BJ7>60792-BJ8	1
E542TR3	AT-Scheibenwischermotor einstufig „DR2“	wiper motor, 1 vitesse „DR2“	BN2-BJ7<60791	1
E542AH	Ritzel Scheibenwischermotor	shaft & gear	BN2-BJ7<60791	2
E543AH	Ritzel Scheibenwischermotor	shaft & gear	BN2-BJ8	2
Scheibenwaschpumpe / Windshield Washers BN1, BN2, BN4 < 68959, BN6 < 1182				
E123SPT	Anlassertaster zur Pumpenbetätigung	starter, for washer pump	BN1,BN2,BN4 < 68959, BN6 < 1182	1
E520TR6	Behälter Scheibenwaschwasser eckig	reservoir, squared	BN1,BN2,BN4 < 68959, BN6 < 1182	1
E521TR6	Halter Scheibenwaschbehälter eckig	bracket, reservoir	BN1,BN2,BN4 < 68959, BN6 < 1182	1
E522TR6	Deckel und Pumpe für E520TR6	cap and pump to no. E520TR6	BN1,BN2,BN4 < 68959, BN6 < 1182	1
E523TR6	Wasserbehälter+Deckel+Pumpe+Halter	reservoir+cap+water pump+bracket	BN1,BN2,BN4 < 68959, BN6 < 1182	1
E525SPT	Scheibenwaschpumpe elektrisch	pump, electrical	BN1,BN2,BN4 < 68959, BN6 < 1182	1
E530VOP1800	Scheibenwaschdüse	jet assembly	BN1,BN2,BN4 < 68959, BN6 < 1182	2
E531SPT	T-Stück	connection, 3-way	BN1,BN2,BN4 < 68959, BN6 < 1182	1
E532SPT	Schlauch Scheibenwaschanlage	tubing	BN1,BN2,BN4 < 68959, BN6 < 1182	A/R
Scheibenwaschpumpe / Windshield Washers BN4 > 68960, BN6 > 1183, BN7, BT7, BJ7				
E520AH	Scheibenwaschbehälter rund ohne Deckel	reservoir, round w/o cap	BN4>68960,BN6>1183,BN7,BT7,BJ7	1
E520AAH	Deckel Scheibenwaschbehälter	cap, reservoir	BN4>68960,BN6>1183, BN7,BT7,BJ7	1
E521AH	Haltebügel Scheibenwaschanlage	bracket	BN4>68960,BN6>1183, BN7,BT7,BJ7	1
E526AH/BJ7	Pumpe Scheibenwaschanlage mechanisch	pump assembly	BN4>68960,BN6,BN7,BT7,BJ7<20125	1
E526SPT	Pumpe Scheibenwaschanlage mechanisch	pump assembly	BJ7>20126	1
E530SPT	Scheibenwaschdüse	jet assembly	BN4>68960, BN6>1183, BN7, BT7,BJ7	2
E531SPT	T-Stück	connection, 3-way	BN4>68960, BN6>1183, BN7, BT7,BJ7	1
E532SPT	Schlauch Scheibenwaschanlage	tubing	BN4>68960, BN6, BN7, BT7, BJ7	A/R
Scheibenwaschpumpe / Windshield Washers BJ8				
E35MGA-32	Kunststoff-Schlauch	tubing	BJ8	A/R
E520SPT	Scheibenwaschbehälter rund	reservoir assembly, round	BJ8	1
E521TR4	Halter für E520SPT	bracket to no. E520SPT	BJ8	1
E526SPT	Pumpe Scheibenwaschanlage	pump assembly	BJ8	1
E530SPT	Scheibenwaschdüse	jet assembly	BJ8	2
E531SPT	T-Stück	connection, 3-way	BJ8	1
E532AH	Rückschlagventil Scheibenwaschanlage	non-return valve	BJ8	1

*) Wir empfehlen eine Umrüstung auf elektrische Pumpe E525SPT in Kombination mit Anlassertaster E123SPT (zum Einbau im Armaturenbrett) zur Pumpenbetätigung / Please use for the no longer available windshield washer the electrical pump E525SPT in combination with starter E123SPT

Frontscheibe / Windshield BN1-BN2

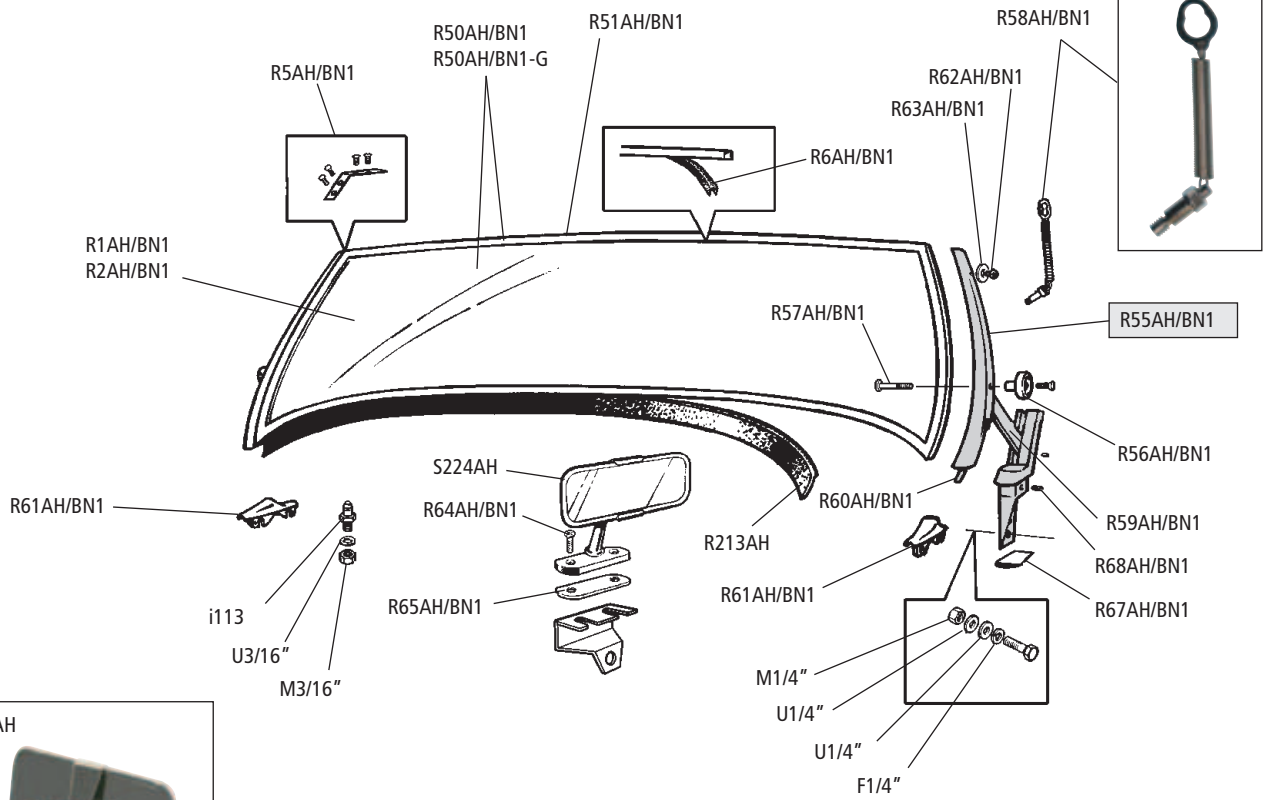

S224AH



Frontscheibe / Windshield BN4, BN6, BN7, BT7

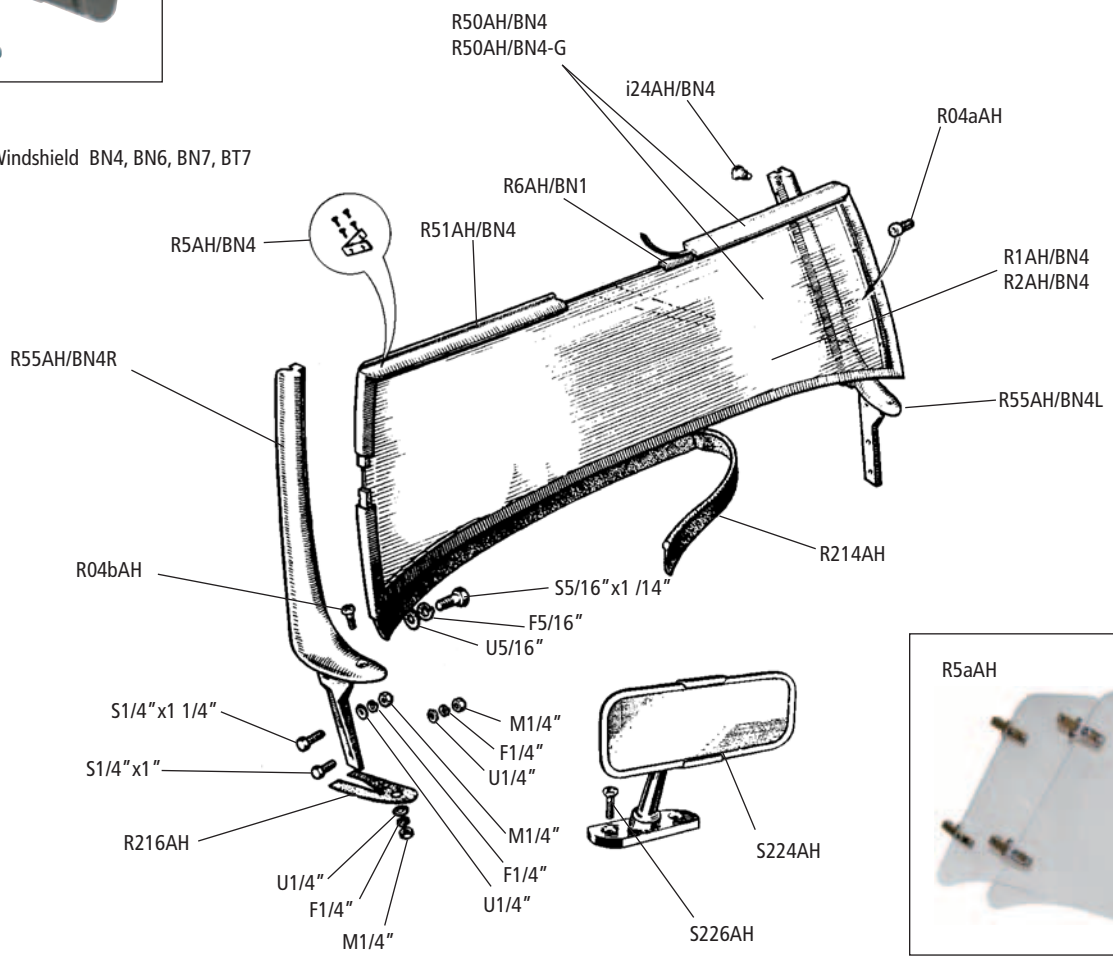

R5aAH



Frontscheibe / Windshield BN1-BN2

No.	Bezeichnung	Description	Type	Anzahl/Qty.
R1AH/BN1	Frontscheibe, klar	glass, windshield, clear	BN1-BN2	1
R2AH/BN1	Frontscheibe, grün getönt	glass, windshield, coloured (green)	BN1-BN2	1
R5AH/BN1	Winkelteile Scheibenrahmen incl. Schrauben	bracket kit, windshield frame, with screws	BN1-BN2	1
R6AH/BN1	Gummi-Dichtung Frontscheibe	glazing rubber	BN1-BN2	1
R50AH/BN1	Frontscheibenrahmen + Scheibe klar	windshield assembly (frame and shield)	BN1-BN2	1
R50AH/BN1-G	Frontscheibenrahmen + Scheibe getönt	windshield assemb. (frame and shield), coloured	BN1-BN2	1
R51AH/BN1	Frontscheibenrahmen	frame, windshield	BN1-BN2	1
R55AH/BN1	Paar Frontscheibenhalter komplett seitlich	pair stanchion and foot, complete assembly	BN1-BN2	1
R56AH/BN1	Rändelmutter Frontscheibe seitlich	knurled knob	BN1-BN2	2
R57AH/BN1	Bolzen für Rändelmutter seitlich incl. Schraube	bolt, shouldered, with screw	BN1-BN2	2
R58AH/BN1	Sicherungsfeder Frontscheibe	security spring assembly	BN1-BN2	2
R59AH/BN1	Verbindung klappbare Frontscheibe	link	BN1-BN2	2
R60AH/BN1	Zentrierstift Frontscheibenrahmen unten	pin, screen pillow, bottom	BN1-BN2	2
R61AH/BN1	Sockel Frontscheibe vorne	foot, forward windshield position	BN1-BN2	2
R62AH/BN1	Stift Verdeckbefestigung an Frontscheibenrahmen	knob, soft top clamp	BN1-BN2	2
R63AH/BN1	Unterlegscheibe für Verdeckhaltestift	washer	BN1-BN2	2
R64AH/BN1	Senkkopfschraube	countersunk screw	BN1-BN2	2
R65AH/BN1	Gewindeplatte für Spiegelhalter	tapped plate	BN1-BN2	1
R66AH/BN1	Halter Innenspiegel	center bracket, dash/driving mirror	BN1-BN2	1
R67AH/BN1	Unterlegplatte Halter Frontscheibenrahmen	packing plate	BN1-BN2	2
R68AH/BN1	Schraube	screw	BN1-BN2	8
i113	Lift the dot Verdeckknopfunterteil Schraubgewinde	fastener, Lift-the-Dot, in-dash	BN1-BN2	2
R213AH	Gummi unter Frontscheibenrahmen	weatherseal, bottom	BN1-BN2	1
S224AH	Innenspiegel chrom	mirror, driving	BN1-BN2	2

Frontscheibe / Windshield BN4, BN6, BN7, BT7

No.	Bezeichnung	Description	Type	Anzahl/Qty.
R1AH/BN4	Frontscheibe, klar	glass, windshield, clear	BN4,BN6,BN7,BT7	1
R2AH/BN4	Frontscheibe, grün getönt	glass, windshield, coloured (green)	BN4,BN6,BN7,BT7	1
R04aAH	Schraube Rahmen/Säule chrom	screw, frame to pillar	BN4,BN6,BN7,BT7	8
R04bAH	Schraube chrom 1/4"x1" UNF	screw, pillar to scuttle top	BN4,BN6,BN7,BT7	2
R5AH/BN4	Winkelteile Scheibenrahmen incl. Schrauben	bracket kit, windshield frame	BN4,BN6,BN7,BT7	1
R5aAH	Paar Windabweiser	wind wing set	BN4,BN6,BN7,BT7	1
R6AH/BN1	Gummi-Dichtung Frontscheibe	glazing seal	BN4,BN6,BN7,BT7	1
i24AH/BN4	Verdeck Befestigungsstift	stud, toggle clamp retaining	BN4,BN6,BN7,BT7	4
R50AH/BN4	Frontscheibenrahmen + Scheibe klar	windshield assembly (frame and shield)	BN4>54755,BN6,BN7,BT7	1
R50AH/BN4-G	Frontscheibenrahmen + Scheibe getönt	windshield assemb. (frame and shield), coloured	BN4>54755,BN6,BN7,BT7	1
R51AH/BN4	Frontscheibenrahmen	frame, windshield	BN4,BN6,BN7,BT7	1
R55AH/BN4R	Frontscheibenhalter rechts seitlich	pillar RH	BN4,BN6,BN7,BT7	1
R55AH/BN4L	Frontscheibenhalter links seitlich	pillar LH	BN4,BN6,BN7,BT7	1
R214AH	Gummi-unter Frontscheibe	seal, windshield frame to body	BN4,BN6,BN7,BT7	1
R216AH	Gummi unter Frontscheibenhalter	pad, pillar foot, rubber	BN4,BN6,BN7,BT7	2
S224AH	Innenspiegel chrom	mirror, driving	BN4,BN6,BN7,BT7	1
S226AH	Senkkopfschraube verchromt 10.32x3/4"	countersunk screw	BN4,BN6,BN7,BT7	2

Frontscheibe / Windshield BJ7, BJ8

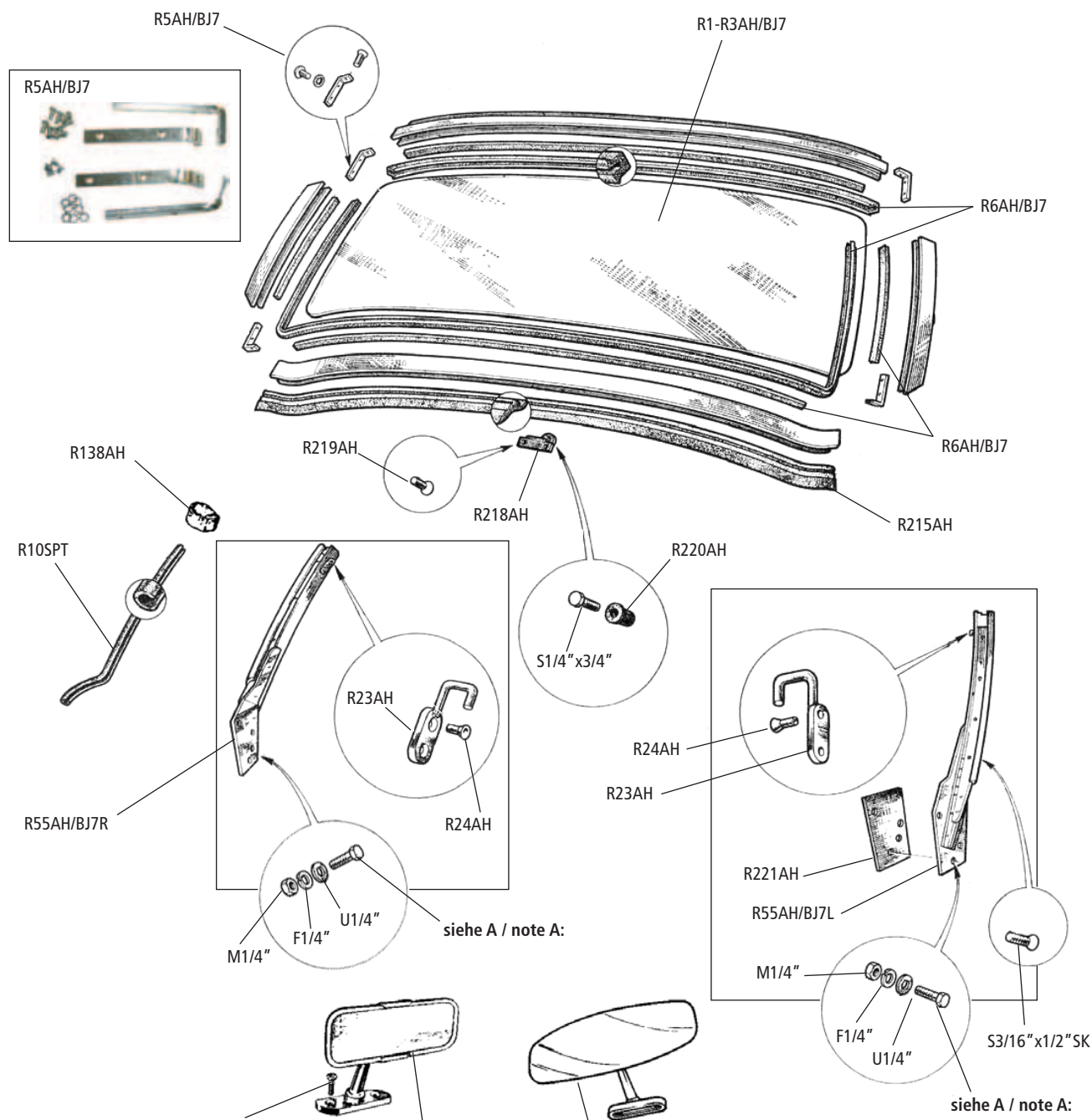

Note A:
 Schraube Länge / Screw length
 1" (BJ7) = Art.no. S1/4"x1"
 3/4" (BJ7) = Art.no. S1/4"x3/4"
 1" (BJ8) = Art.no. S1/4"x1"
 3/4" (BJ8) = Art.no. S1/4"x3/4"
 1 1/4" (BJ8) = Art.no. S1/4"x1 1/4"

Frontscheibe / Windshield BJ7, BJ8

No.	Bezeichnung	Description	Type	Anzahl/Qty.
R1AH/BJ7	Frontscheibe, klar	glass, windshield, clear	BJ7, BJ8	1
R2AH/BJ7	Frontscheibe, grün getönt	glass, windshield, coloured (green)	BJ7, BJ8	1
R3AH/BJ7	Frontscheibe, grün getönt, mit Grünkeil	glass, windshield, coloured (green) + wedge	BJ7, BJ8	1
R5AH/BJ7	Satz Haltewinkel Frontscheibenrahmen incl. Schrauben	bracket kit, windshield frame with screws	BJ7, BJ8	1
R6AH/BJ7	Gummi-Dichtung Frontscheibe	glazing seal kit	BJ7, BJ8	1
R10SPT	Dichtungen an Frontscheibenrahmen außen schwarz, per Meter	pillar seal, black per metre	BJ7, BJ8	A/R
R23AH	Paar Haken Verdeckbefestigung an Frontscheibenrahmen	hook pair, toggle	BJ7, BJ8	1
R24AH	Niete	rivet, hook	BJ7, BJ8	4
R50AH/BJ7	Frontscheibenrahmen + Scheibe klar	windshield assembly (frame + shield) clear	BJ7, BJ8	1
R50AH/BJ7-G	Frontscheibenrahmen + Scheibe grün getönt	windshield assembly (frame + shield) green coloured	BJ7, BJ8	1
R50AH/BJ7-GK	Frontscheibenrahmen + Scheibe grün getönt + Keil	windshield assembly (frame + shield) green coloured + wedge	BJ7, BJ8	1
R55AH/BJ7L	Frontscheibenhalter links seitlich	pillar LH	BJ7, BJ8	1
R55AH/BJ7R	Frontscheibenhalter rechts seitlich	pillar RH	BJ7, BJ8	1
R138AH/L	Verdeck-Schutzzecke links	cap, seal top, LH	BJ7, BJ8	1
R138AH/R	Verdeck-Schutzzecke rechts	cap, seal top, RH	BJ7, BJ8	1
R215AH	Gummi unter Frontscheibenrahmen	weatherseal, bottom	BJ7, BJ8	1
R218AH	Halterung Scheibenrahmen mitte	bracket, center	BJ7, BJ8	1
R219AH	Senkkopfschraube	screw, center bracket to top channel	BJ7, BJ8	2
R220AH	Mutter Frontscheibenbefestigung Mitte	nut	BJ7, BJ8	1
R221AH	Unterlage Frontscheibenhalter an Karroserie	packing, foot	BJ7, BJ8	A/R
S224AH	Innenspiegel chrom	mirror, driving	BJ8<73213	1
S224AH/BJ8	Innenspiegel	mirror, driving	BJ8>73214	1
S226AH	Senkkopfschraube verchromt	countersunk screw	BJ7, BJ8	2
S3/16"X1/2"SK	Senkkopf-Schraube 3/16" x 1/2" UNF	countersunk screw 3/16" x 1/2" UNF	BJ7, BJ8	8

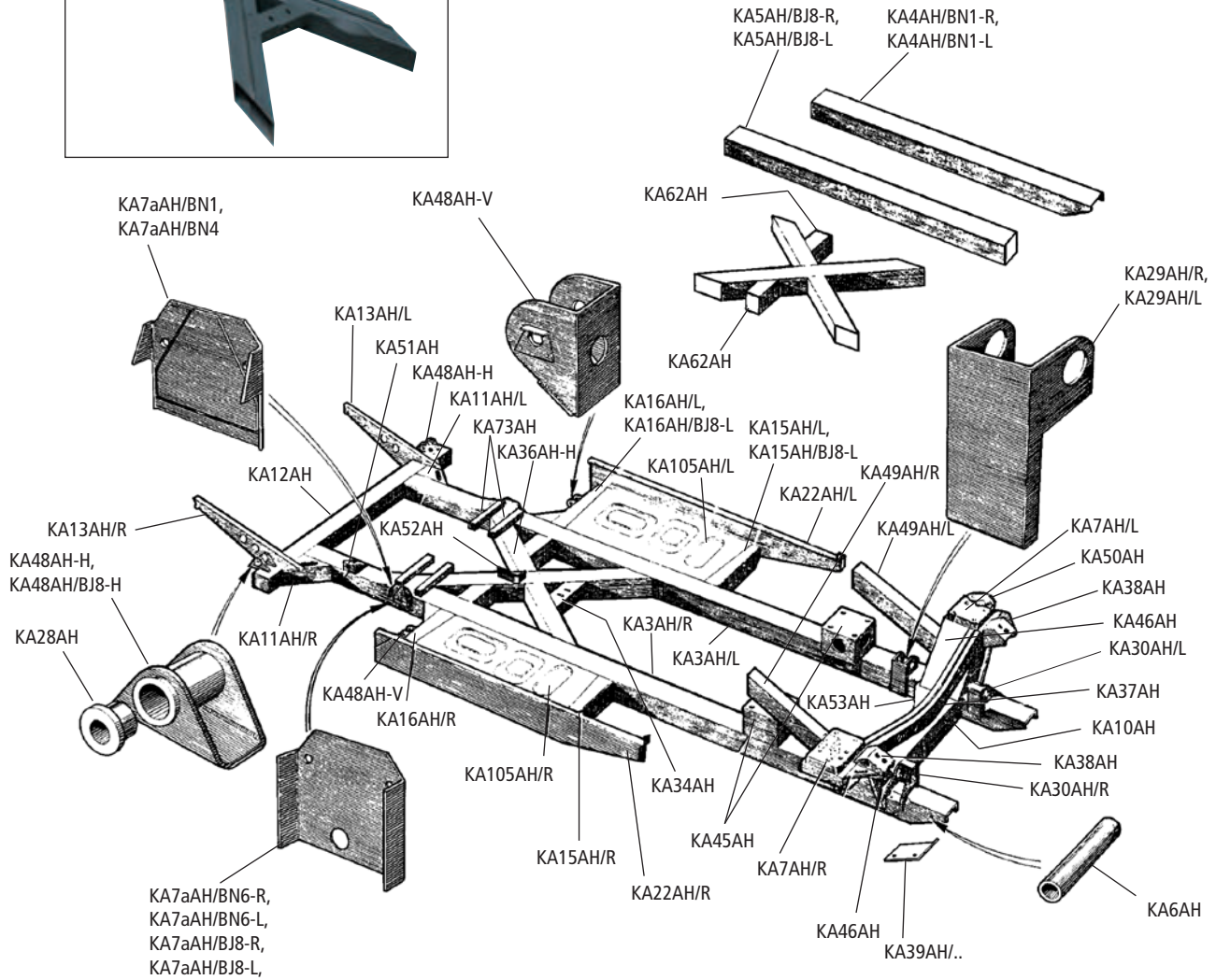

No.	Bezeichnung	Description	Type	Anzahl/Req.
KA3AH/BN1-R	Längsträger Fahrgestell rechts	chassis rail, RH	BN1, BN2	1
KA3AH/BN1-L	Längsträger Fahrgestell links	chassis rail, LH	BN1, BN2	1
KA3AH/R	Längsträger Fahrgestell rechts	chassis rail, RH	BN4, BN6, BN7, BT7, BJ7, BJ8<26704	1
KA3AH/L	Längsträger Fahrgestell links	chassis rail, LH	BN4, BN6, BN7, BT7, BJ7, BJ8<26704	1
KA3AH/BJ8-R	Längsträger Fahrgestell rechts	chassis rail, RH	BJ8 > 26705	1
KA3AH/BJ8-L	Längsträger Fahrgestell links	chassis rail, LH	BJ8 > 26705	1
KA4AH-R	Hauptträger (1/2) Chassis vorne rechts	chassis rail repair (1/2), front RH	BN1-BJ8	1
KA4AH-L	Hauptträger (1/2) Chassis vorne links	chassis rail repair (1/2), front LH	BN1-BJ8	1
KA5AH/BN1-R	Hauptträger (1/2) Chassis hinten rechts	chassis rail repair (1/2), rear RH	BN1, BN2	1
KA5AH/BN1-L	Hauptträger (1/2) Chassis hinten links	chassis rail repair (1/2), rear LH	BN1, BN2	1
KA5AH/BN4-R	Hauptträger (1/2) Chassis hinten rechts	chassis rail repair (1/2), rear RH	BN4, BN6, BN7, BT7, BJ7, BJ8<26704	1
KA5AH/BN4-L	Hauptträger (1/2) Chassis hinten links	chassis rail repair (1/2), rear LH	BN4, BN6, BN7, BT7, BJ7, BJ8<26704	1
KA5AH/BJ8-R	Hauptträger (1/2) Chassis hinten rechts	chassis rail repair (1/2), rear RH	BJ8 > 26705	1
KA5AH/BJ8-L	Hauptträger (1/2) Chassis hinten links	chassis rail repair (1/2), rear LH	BJ8 > 26705	1
KA6AH	Rohr Stoßstangenbefestigung	tube, front bumper mounting	BN4, BN6, BN7, BT7, BJ7, BJ8	4
KA7AH/R	Stossdämpfer-Halter vorne RH	mounting plate, RH shock	BN1-BJ8	1
KA7AH/L	Stossdämpfer-Halter vorne LH	mounting plate, LH shock	BN1-BJ8	1
KA7aAH/BN1	Stossdämpfer-Halter hinten	bracket, rear shock mount	BN1, BN2	2
KA7aAH/BN4	Stossdämpfer-Halter hinten	bracket, rear shock mount	BN4	2
KA7aAH/BN6-L	Stossdämpfer-Halter hinten LH	bracket, rear shock mount, LH	BN6, BN7	1
KA7aAH/BN6-R	Stossdämpfer-Halter hinten RH	bracket, rear shock mount, RH	BN6, BN7	1
KA7aAH/BT7-L	Stossdämpfer-Halter hinten LH	bracket, rear shock mount, LH	BT7, BJ7, BJ8 < 26704	1
KA7aAH/BT7-R	Stossdämpfer-Halter hinten RH	bracket, rear shock mount, RH	BT7, BJ7, BJ8 < 26704	1
KA7aAH/BJ8-R	Stossdämpfer-Halter hinten RH	bracket, rear shock mount, RH	BJ8 > 26705	1
KA7aAH/BJ8-L	Stossdämpfer-Halter hinten LH	bracket, rear shock mount, LH	BJ8 > 26705	1
KA10AH	Querträger vorne	crossmember, front	BN1-BJ8	1
KA11AH/L	Verstärkung Chassis-Querträger links,	gusset, rear crossmember, LH	BN1, BN2, BN4, BN6, BN7, BT7, BJ7	1
KA11AH/R	Verstärkung Chassis-Querträger rechts	gusset, rear crossmember, RH	BN1, BN2, BN4, BN6, BN7, BT7, BJ7, BJ8	1
KA11AH/BJ8L	Verstärkung Chassis-Querträger links	gusset, rear crossmember, LH	BJ8	1
KA12AH/BN1	Chassis-Querträger hinten	crossmember, rear, with spring hangers	BN1-BN2	1
KA12AH/BN4	Chassis-Querträger hinten	crossmember, rear, with spring hangers	BN4, BN6, BN7, BT7, BJ7, BJ8 < 26704	1
KA12AH/BJ8	Chassis-Querträger hinten	crossmember, rear, with spring hangers	BJ8 > 26705	1
KA13AH/BN1R	Rahmen-Endteil re Aufnahme Stoßstangenhalter	bracket, rear bumper, RH	BN1-BN2	1
KA13AH/BN1L	Rahmen-Endteil li Aufnahme Stoßstangenhalter	bracket, rear bumper, LH	BN1-BN2	1
KA13AH/BN4R	Rahmen-Endteile RH	bracket, rear bumper, RH	BN4-BJ8	1
KA13AH/BN4L	Rahmen-Endteile LH	bracket, rear bumper, LH	BN4-BJ8	1
KA15AH/R	Querträger vorne rechts	outrigger, front, RH	BN1-BJ8	1
KA15AH/L	Querträger vorne links	outrigger, front, LH	BN1-BJ7	1
KA15AH/BJ8-L	Querträger vorne links	outrigger, front, LH	BJ8	1
KA16AH/R	Querträger hinten rechts	outrigger, rear, RH	BN1-BJ8	1
KA16AH/L	Querträger hinten links	outrigger, rear, LH	BN1-BJ7	1
KA16AH/BJ8-L	Querträger hinten links	outrigger, rear, LH	BJ8	1
KA22AH/R	Innenschweller rechts	inner sill assembly, RH	BN1-BJ8	1
KA22AH/L	Innenschweller links	inner sill assembly, LH	BN1-BJ8	1
KA28AH	Lagerbuchse im Rahmen	bush, shackle pin	BN1, BJ8 < 26704	4
KA28AH/BJ8	Lagerbuchse im Rahmen	bush, shackle pin	BJ8 > 26705	4
KA29AH/R	Vorderachs-Halterung hinten RH	bracket, lower link, rear RH	BN1-BN2	1
KA29AH/L	Vorderachs-Halterung hinten LH	bracket, lower link, rear LH	BN1-BN2	1
KA30AH/BN1-R	Vorderachs-Halterung vorne RH	bracket, lower link, front RH	BN1, BN2	1
KA30AH/BN1-L	Vorderachs-Halterung vorne LH	bracket, lower link, front LH	BN1, BN2	1
KA30AH/R	Vorderachs-Halterung vorne RH	bracket, lower link, front RH	BN4-BJ8	1
KA30AH/L	Vorderachs-Halterung vorne LH	bracket, lower link, front LH	BN4-BJ8	1
KA34AH	Chassis-Kreuz	cross brace assembly	BN1-BJ8	1
KA37AH	Chassis-Verbinder vorne	support, suspension housing	BN4-BJ8	1
KA38AH	Halter Lenkgetriebe	bracket, steering	BN1-BJ8	2
KA39AH/BN1-R	Abschlussblech Längsträger RH	bracket, sway bar mount, RH	BN1-BN2	1
KA39AH/BN1-L	Abschlussblech Längsträger LH	bracket, sway bar mount, LH	BN1-BN2	1
KA39AH/BN4-R	Abschlussblech Längsträger RH	bracket, sway bar mount, RH	BN4-BJ8	1
KA39AH/BN4-L	Abschlussblech Längsträger LH	bracket, sway bar mount, LH	BN4-BJ8	1

- Fortsetzung s. nächste Seite

- to be continued on next page

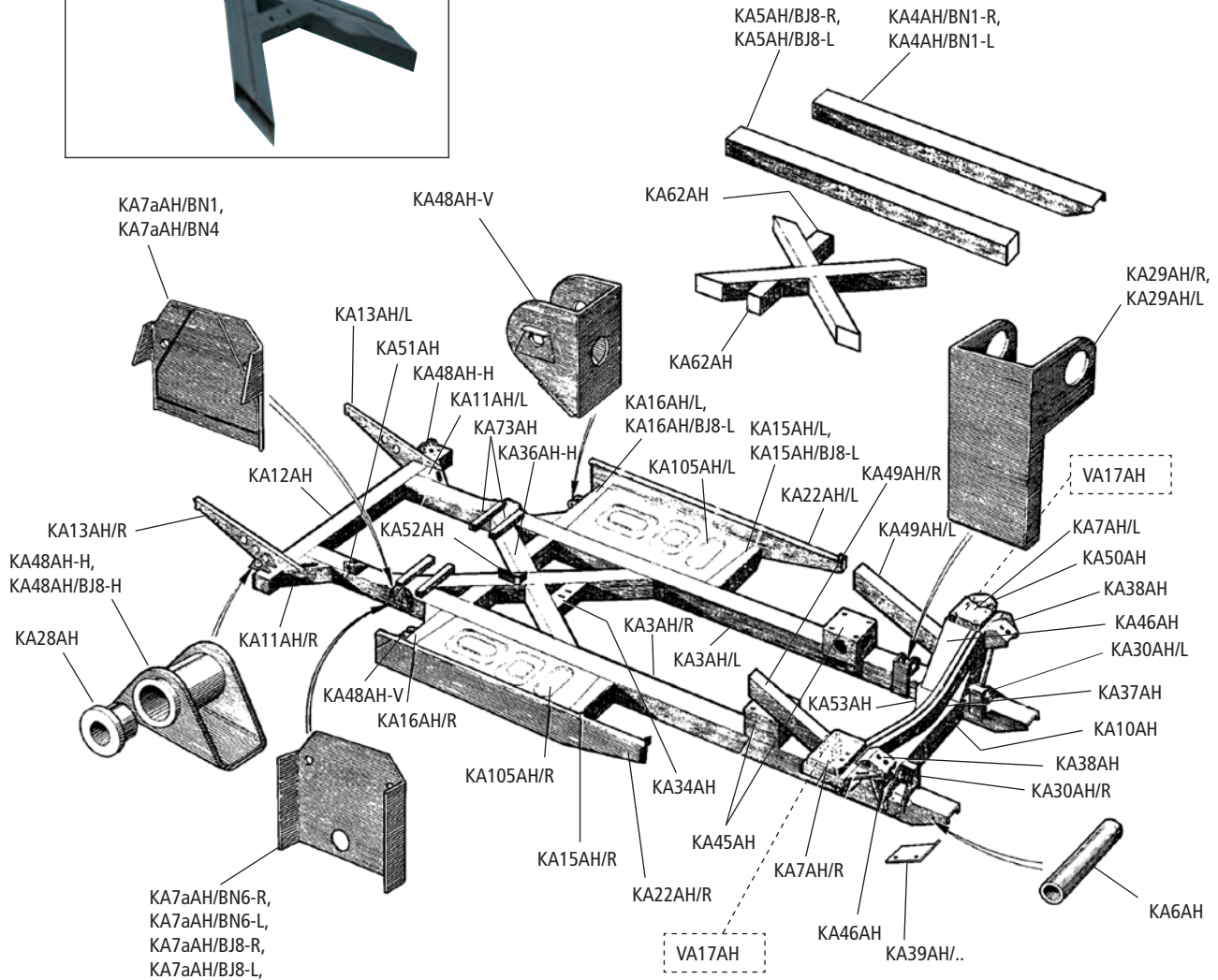
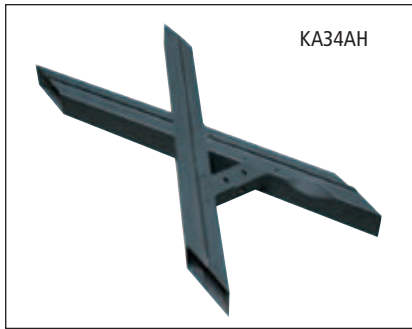

No.	Bezeichnung	Description	Type	Anzahl/Req.
KA45AH/BN1	Auflagebock Motorhalter (Paar)	platform, engine mount (pair)	BN1, BN2	1
KA45AH	Auflagebock Motorhalter (Paar)	platform, engine mount (pair)	BN4-BJ8	1
KA46AH	Halteurm Vorderachse	housing, front suspension	BN4-BJ8	2
KA48AH-H	Halter Blattfeder hinten	bracket, rear spring, rear	BN1-BJ8 < 26704	2
KA48AH-V	Halter Blattfeder vorne	bracket, rear spring, front	BN1-BJ8 < 27604	2
KA48AH/BJ8-H	Halter Blattfeder hinten	bracket, rear spring, rear	BJ8 > 26705	2
KA49AH/R	Strebe Motorhalter rechts	strut, RH	BN4-BJ8	1
KA49AH/L	Strebe Motorhalter links	strut, LH	BN4-BJ8	1
KA50AH	Stossdämpfer-Kappe	cup, bumper	BN1-BJ8	2
KA51AH	Halter Panhardstab	bracket, panhard rod	BN1-BJ8 < 26704	1
KA52AH	Halter Handbrems-Seil hinten	bracket, handbrake	BN4-BJ8	1
KA53AH	Verstärkung Querträger vorne	gusset, front crossmember	BN1-BJ8	2
KA62AH	Strebe Chassis-Kreuz	stiffener, cross brace	BN4-BJ8	2
KA73AH	Batterie Halteset (4 Stück)	bracket set, battery (4 pieces)	BN1, BN2	1
KA100AH/BN1-F	Chassis	chassis assembly	BN1 C.138031-140204	1
KA100AH/BN1-S	Chassis	chassis assembly	BN1 C.140205-CE.228046	1
KA100AH/BN2	Chassis	chassis assembly	BN2	1
KA100AH/BN4	Chassis	chassis assembly	BN4, BN6, BN7, BT7, BJ7, BJ8 < 26704	1
KA100AH/BJ8	Chassis	chassis assembly	BJ8 > 26705	1
KA105AH/R	Bodenblech rechts	floor panel, RH	BN1-BJ8	1
KA105AH/L	Bodenblech links	floor panel, LH	BN1-BJ8	1
VA17AH	Schiebeplatte Sturzeinstellung	front shock sliding plate	BN1-BJ8	2
VA17AH/L	Stoßdämpfer Halteplatte links mit Langlöchern (muss eingeschweißt werden)	bracket shock absorber LH with slotted holes (must be weld in)	BN1-BJ8	1
VA17AH/R	Stoßdämpfer Halteplatte rechts mit Langlöchern (muss eingeschweißt werden)	bracket shock absorber RH with slotted holes (must be weld in)	BN1-BJ8	1

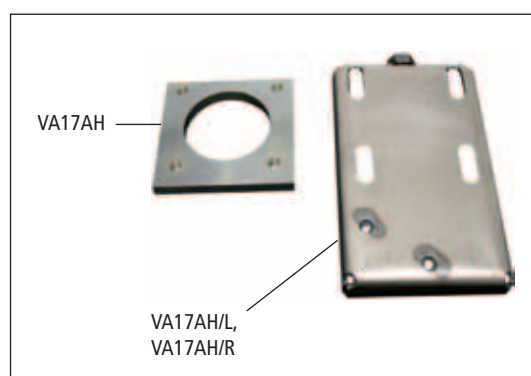

Karosserie / Outer Body Panels BN1-BN2

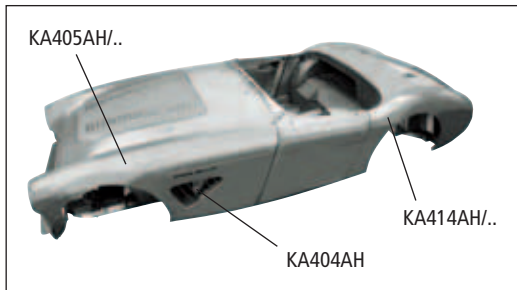
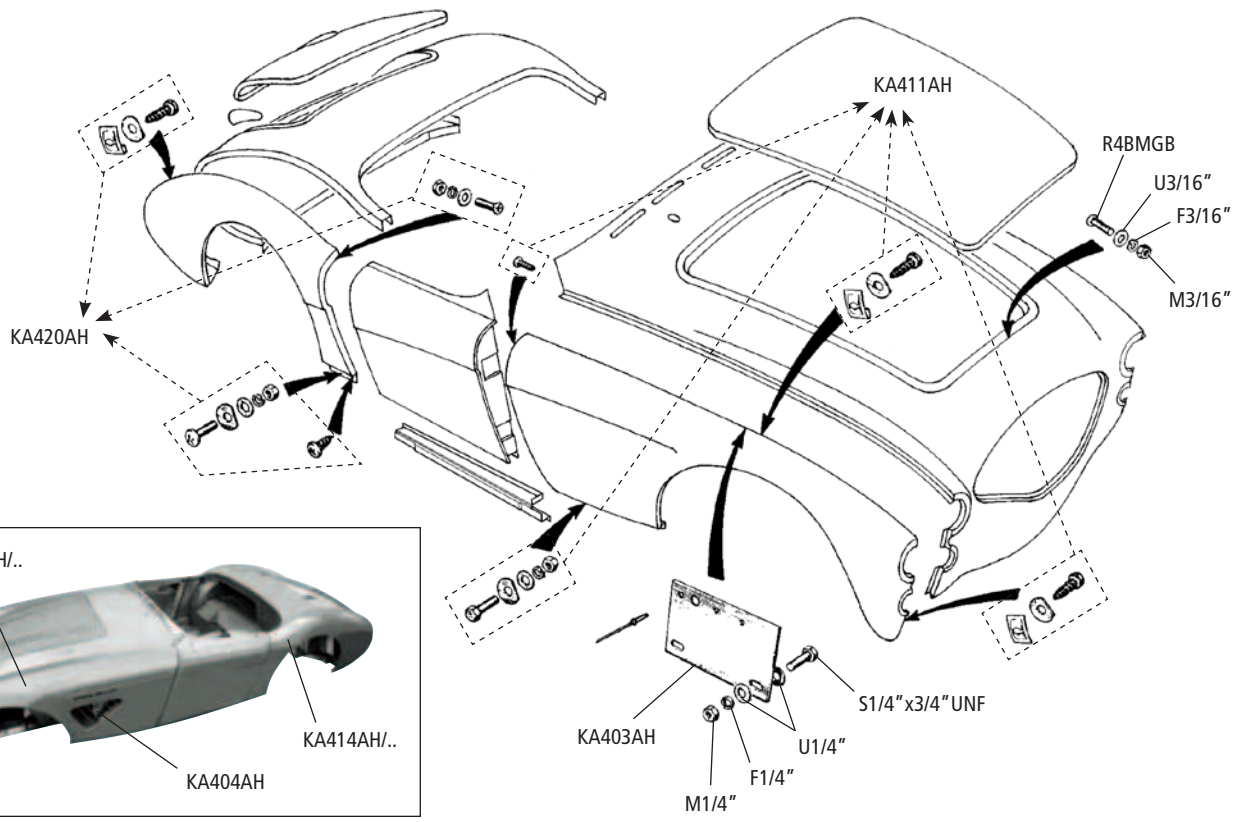
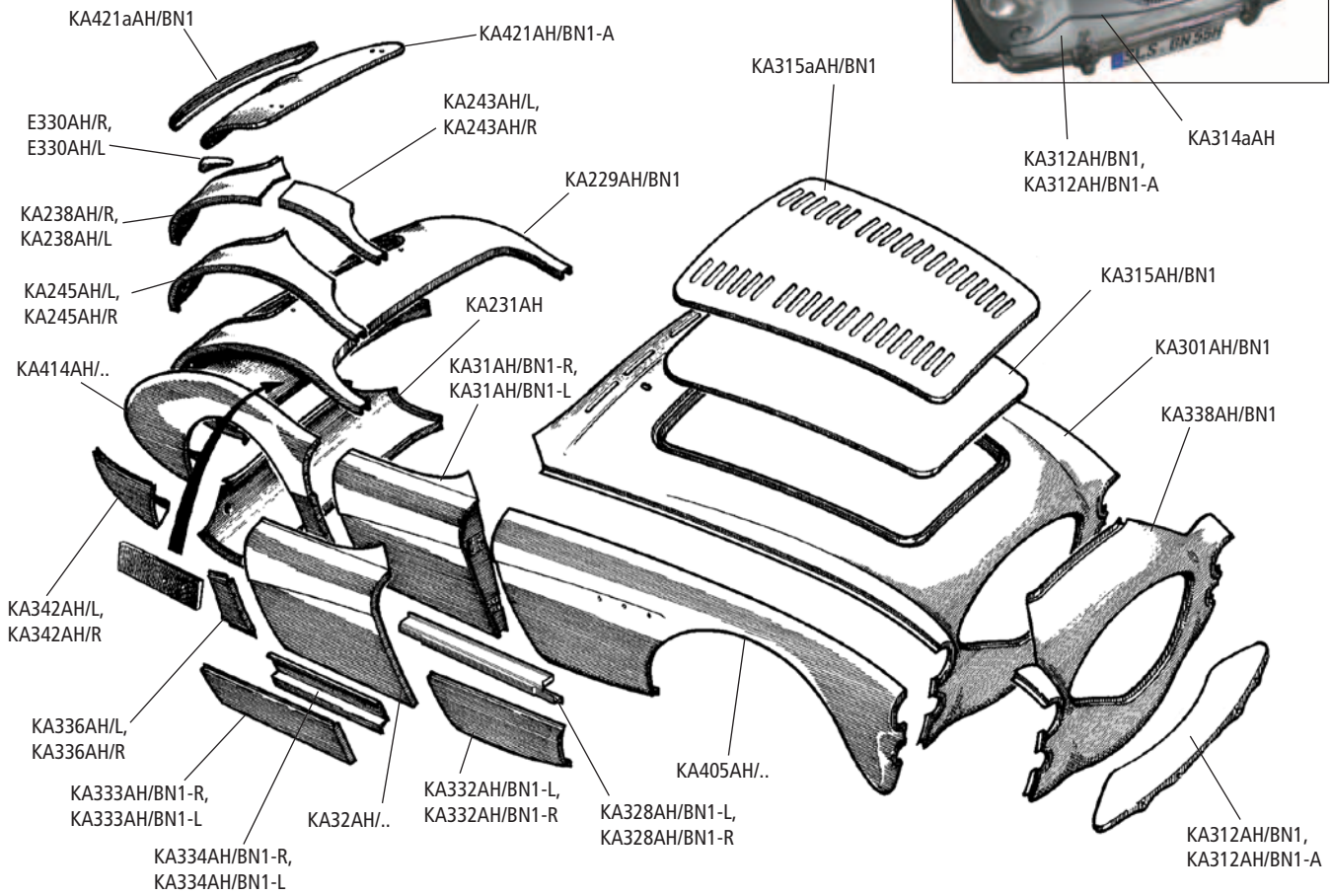
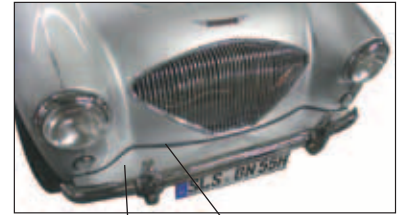

No.	Bezeichnung	Description	Type	Anzahl/Req.
R4BMGB	Senkkopfschraube kurz 3/16"x5/8" UNF	countersunk screw „short“ 3/16"x5/8" UNF	BN1-BN2	A/R
KA31AH/BN1-L	Türe Aluminium links	door, aluminum LH	BN1-BN2	1
KA31AH/BN1-R	Türe Aluminium rechts	door, aluminum RH	BN1-BN2	1
KA32AH/BN1-R	Türhaut rechts	door skin RH	BN1-BN2	1
KA32AH/BN1-L	Türhaut links	door skin LH	BN1-BN2	1
KA32AH/BN1-RA	Türhaut rechts Aluminium	door skin, aluminum RH	BN1-BN2	1
KA32AH/BN1-LA	Türhaut links Aluminium	door skin, aluminum LH	BN1-BN2	1
KA229AH/BN1	Heckblech komplett	rear shroud assembly	BN1-BN2	1
KA231AH	Heckblech Unterteil	rear skirt panel	BN1-BN2	1
KA238AH/R	Rep.-Blech Heckblech unten RH	shroud side, lower RH	BN1-BN2	1
KA238AH/L	Rep.-Blech Heckblech unten LH	shroud side, lower LH	BN1-BN2	1
KA243AH/R	Rep.-Blech Heckblech oben RH	shroud side, upper RH	BN1-BN2	1
KA243AH/L	Rep.-Blech Heckblech oben LH	shroud side, upper LH	BN1-BN2	1
KA245AH/R	Rep.-Blech Heckblech komplett RH	shroud side, complete RH	BN1-BN2	1
KA245AH/L	Rep.-Blech Heckblech komplett LH	shroud side, complete LH	BN1-BN2	1
KA301AH/BN1	Frontmaske komplett	front shroud assembly	BN1-BN2	1
KA312AH/BN1	Frontblech unten Stahl	front apron, steel	BN1-BN2	1
KA312AH/BN1-A	Frontblech unten Aluminium	front apron, aluminum	BN1-BN2	1
KA314aAH	Kederband für KA312AH/..	welting for KA312AH/..	BN1-BN2	1
KA315AH/BN1	Motorhaube Aluminium	hood assy, plain, aluminum	BN1-BN2	1
KA315aAH/BN1	Motorhaube Aluminium + Rillen „Le Mans“	hood assy, louvred, aluminum „Le Mans“	BN1-BN2	1
KA328AH/BN1-R	Türschweller aussen rechts	rocker panel RH	BN1-BN2	1
KA328AH/BN1-L	Türschweller aussen links	rocker panel LH	BN1-BN2	1
E330AH/R	Gehäuse Reflektor rechts	plinth, (pod) RH	BN1-BN2	1
E330AH/L	Gehäuse Reflektor links	plinth, (pod) LH	BN1-BN2	1
E331AH	Gummi-Unterlage Gehäuse	plinth pad	BN1-BN2	2
KA332AH/BN1-R	Rep.-Blech Kotflügel vorne RH	front fender repair RH	BN1-BN2	1
KA332AH/BN1-L	Rep.-Blech Kotflügel vorne LH	front fender repair LH	BN1-BN2	1
KA333AH/BN1-R	Rep.-Blech Türe unten RH	repair panel, lower RH	BN1-BN2	1
KA333AH/BN1-L	Rep.-Blech Türe unten LH	repair panel, lower LH	BN1-BN2	1
KA334AH/BN1-R	Rep.-Blech Türrahmen unten RH	frame repair, lower RH	BN1-BN2	1
KA334AH/BN1-L	Rep.-Blech Türrahmen unten LH	frame repair, lower LH	BN1-BN2	1
KA336AH/R	Rep.-Blech hinterer Kotflügel, vorne RH	rear fender repair, front RH	BN1-BN2	1
KA336AH/L	Rep.-Blech hinterer Kotflügel, vorne LH	rear fender repair, front LH	BN1-BN2	1
KA338AH/BN1	Nase Frontblech	shroud nose panel	BN1-BN2	1
KA342AH/R	Rep.-Blech hinterer Kotflügel, hinten RH	rear fender repair, rear RH	BN1-BN2	1
KA342AH/L	Rep.-Blech hinterer Kotflügel, hinten LH	rear fender repair, rear LH	BN1-BN2	1
KA403AH	Halter Kotflügel vorne	bracket, front fender support	BN1-BN2	2
KA404AH	Luftschlitze vorne Paar (ohne Kante)	vent pair	BN1-BN2	1
KA405AH/BN1RA	Kotflügel vorne rechts Aluminium	front fender, aluminum RH	BN1	1
KA405AH/BN1LA	Kotflügel vorne links Aluminium	front fender, aluminum LH	BN1	1
KA405AH/BN2R	Kotflügel vorne rechts	front fender, RH	BN2	1
KA405AH/BN2L	Kotflügel vorne links	front fender, LH	BN2	1
KA405AH/BN2RA	Kotflügel vorne rechts Aluminium	front fender, aluminum RH	BN2	1
KA405AH/BN2LA	Kotflügel vorne links Aluminium	front fender, aluminum LH	BN2	1
KA411AH	Schrauben-Satz Kotflügel (1) vorne	fitting kit, front fender (1)	BN1-BN2	2
KA414AH/BN1R	Kotflügel hinten rechts, Stahl	rear fender RH, steel	BN1	1
KA414AH/BN1L	Kotflügel hinten links, Stahl	rear fender LH, steel	BN1	1
KA414AH/BN1RA	Kotflügel hinten rechts Aluminium	rear fender, aluminum RH	BN1	1
KA414AH/BN1LA	Kotflügel hinten links Aluminium	rear fender, aluminum LH	BN1	1
KA414AH/R	Kotflügel hinten rechts, Stahl	rear fender RH, steel	BN2	1
KA414AH/L	Kotflügel hinten links, Stahl	rear fender LH, steel	BN2	1
KA414AH/L-ALU	Kotflügel hinten links Aluminium	rear fender, aluminum RH	BN2	1
KA414AH/R-ALU	Kotflügel hinten rechts Aluminium	rear fender, aluminum LH	BN2	1
KA420AH	Schrauben-Satz Kotflügel (1) hinten	fitting kit, rear fender	BN1-BN2	2
KA421AH/BN1-A	Kofferraum-Deckel Aluminium	trunk lid, aluminum	BN1-BN2	1
KA421aAH/BN1	Rep.-Blech Kofferraumdeckel	trunk lid repair panel	BN1-BN2	1
KA426AH	Korrosionsschutzband	anti-corrosion joint strip	BN1-BN2	1

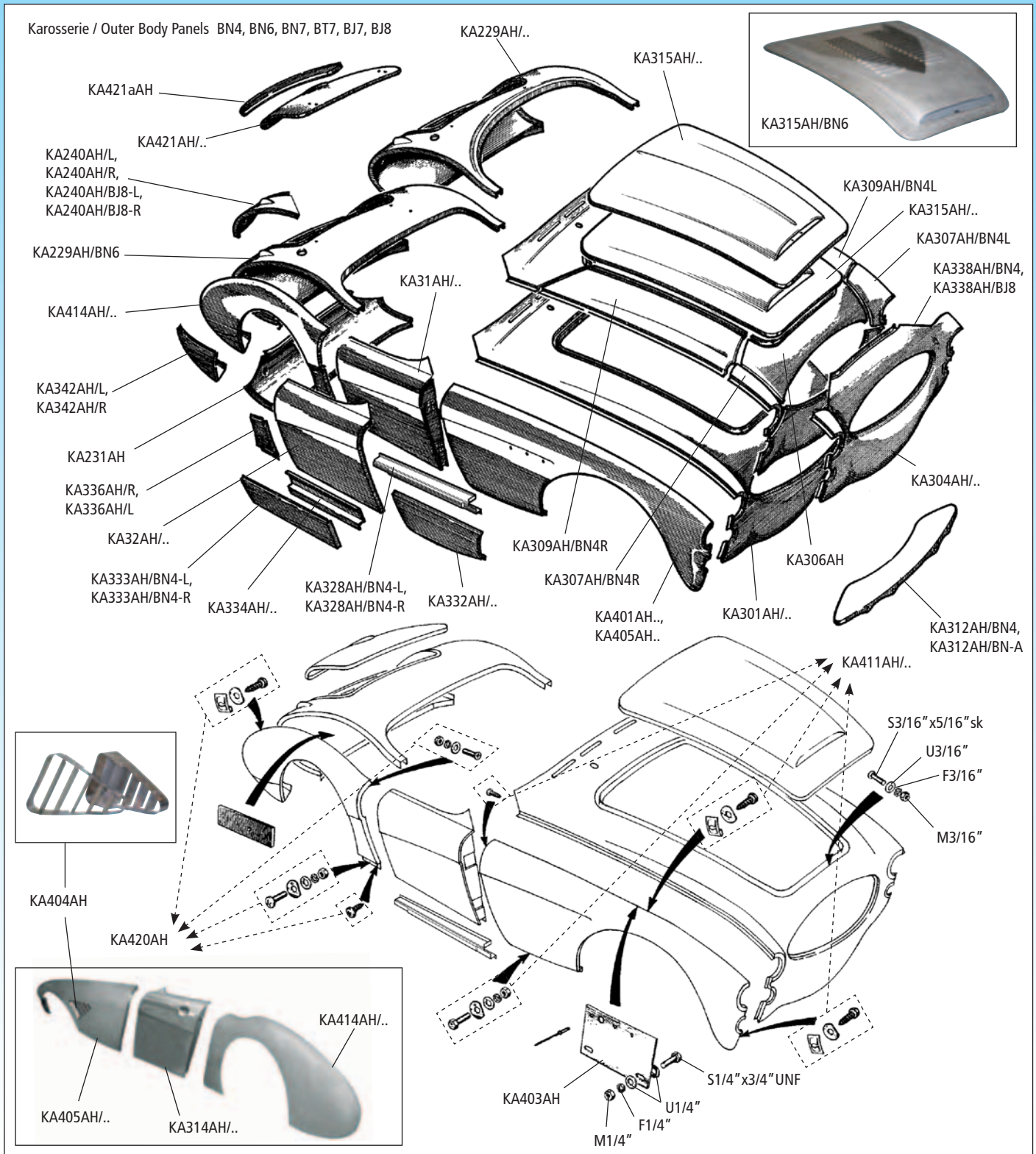

No.	Bezeichnung	Description	Type	Anzahl/Req.
KA31AH/BN4-R	Türe Aluminium rechts	door aluminum RH	BN4, BN6, BN7, BT7	1
KA31AH/BN4-L	Türe Aluminium links	door aluminum LH	BN4, BN6, BN7, BT7	1
KA31AH/BJ7-R	Türe Aluminium rechts	door aluminum RH	BJ7-BJ8<25314	1
KA31AH/BJ7-L	Türe Aluminium links	door aluminum LH	BJ7-BJ8<25314	1
KA31AH/BJ8s-R	Türe Aluminium rechts	door aluminum RH	BJ8<26705	1
KA31AH/BJ8s-L	Türe Aluminium links	door aluminum LH	BJ8<26705	1
KA31AH/BJ8f-R	Türe Aluminium rechts	door aluminum RH	BJ8>25315-26704	1
KA31AH/BJ8f-L	Türe Aluminium links	door aluminum LH	BJ8>25315-26704	1
KA32AH/BN4-R	Türhaut rechts	door skin RH	BN4, BN6, BN7, BT7	1
KA32AH/BN4-L	Türhaut links	door skin LH	BN4, BN6, BN7, BT7	1
KA32AH/BN4-RA	Türhaut rechts Aluminium	door skin, aluminum RH	BN4, BN6, BN7, BT7	1

No.	Bezeichnung	Description	Type	Anzahl/Req.
KA32AH/BN4-LA	Türhaut links Aluminium	door skin, aluminum LH	BN4, BN6, BN7, BT7	1
KA334AH/BN4-R	Rep.-Blech Türrahmen unten RH	frame repair, lower RH	BN4, BN6, BN7, BT7	1
KA334AH/BN4-L	Rep.-Blech Türrahmen unten LH	frame repair, lower LH	BN4, BN6, BN7, BT7	1
KA32AH/BJ7-R	Türhaut rechts	door skin RH	BJ7	1
KA32AH/BJ7-L	Türhaut links	door skin LH	BJ7	1
KA32AH/BJ8-R	Türhaut rechts	door skin RH	BJ8	1
KA32AH/BJ8-L	Türhaut links	door skin LH	BJ8	1
KA32AH/BJ8-RA	Türhaut rechts Aluminium	door skin, aluminum RH	BJ8	1
KA32AH/BJ8-LA	Türhaut links Aluminium	door skin, aluminum LH	BJ8	1
KA229AH/BN4	Heckblech komplett	rear shroud assembly	BN4 + BT7	1
KA229AH/BJ7	Heckblech komplett	rear shroud assembly	BJ7 - BJ8 < 76137	1
KA229AH/BJ8	Heckblech komplett	rear shroud assembly	BJ8 > 76138	1
KA229AH/BN6	Heckblech komplett	rear shroud assembly	BN6, BN7	1
KA231AH	Heckblech Unterteil	rear skirt panel	BN4, BN6, BN7, BT7, BJ7, BJ8	1
KA240AH/L	Rep.-Blech Heckblech links	shroud side, LH	BN4, BN6, BN7, BT7, BJ7, BJ8 < 76137	1
KA240AH/R	Rep.-Blech Heckblech rechts	shroud side, RH	BN4, BN6, BN7, BT7, BJ7, BJ8 < 76137	1
KA240AH/BJ8-R	Rep.-Blech Heckblech rechts	shroud side, RH	BJ8 > 76138	1
KA240AH/BJ8-L	Rep.-Blech Heckblech links	shroud side, LH	BJ8 > 76138	1
KA301AH/BN4	Frontmaske komplett	front shroud assembly	BN4, BN6, BN7, BT7	1
KA301AH/BJ7	Frontmaske komplett	front shroud assembly	BJ7, BJ8 < 76137	1
KA301AH/BJ8	Frontmaske komplett	front shroud assembly	BJ8 > 76138	1
KA304AH/BN4	Frontmaske unten Aluminium	front apron, aluminum	BN4, BN6, BN7, BT7, BJ7, BJ8 < 76137	1
KA304AH/BJ8	Frontmaske unten Aluminium	front apron, aluminum	BJ8 > 76138	1
KA306AH	Frontmaske Oberteil	front upper repair	BN4, BN6, BN7, BT7, BJ7, BJ8	1
KA307AH/BN4R	Scheinwerfer-Einfassung rechts	front upper qtr. RH	BN4, BN6, BN7, BT7, BJ7, BJ8	1
KA307AH/BN4L	Scheinwerfer-Einfassung links	front upper qtr. LH	BN4, BN6, BN7, BT7, BJ7, BJ8	1
KA309AH/BN4R	Seite Frontblech rechts	shroud side repair RH	BN4, BN6, BN7, BT7, BJ7, BJ8	1
KA309AH/BN4L	Seite Frontblech links	shroud side repair LH	BN4, BN6, BN7, BT7, BJ7, BJ8	1
KA312AH/BN4	Frontblech unten Stahl	front apron panel, steel	BN4, BN6, BN7, BT7, BJ7, BJ8	1
KA312AH/BN4-A	Frontblech unten Aluminium	front apron panel, aluminum	BN4, BN6, BN7, BT7, BJ7, BJ8	1
KA315AH/BN4	Motorhaube Aluminium mit Sicke	hood assy, aluminum, ribbed	BN4 + BN6	1
KA315AH/BN6	Motorhaube Aluminium mit Schlitzen	hood assy, louvred, aluminum	BN6, BN7, BT7, BJ7, BJ8	1
KA315AAH/BN6	Motorhaube Aluminium flach	hood assy, plain, aluminum	BN6, BN7, BT7, BJ7, BJ8	1
KA328AH/BN4-R	Türschweller aussen rechts	rocker panel RH	BN4, BN6, BN7, BT7, BJ7, BJ8	1
KA328AH/BN4-L	Türschweller aussen links	rocker panel LH	BN4, BN6, BN7, BT7, BJ7, BJ8	1
KA332AH/BN4-R	Rep.-Blech Kotflügel vorne rechts	front fender repair RH	BN4, BN6, BN7, BT7, BJ7, BJ8	1
KA332AH/BN4-L	Rep.-Blech Kotflügel vorne links	front fender repair LH	BN4, BN6, BN7, BT7, BJ7, BJ8	1
KA333AH/BN4-R	Rep.-Blech Türhaut unten RH	skin repair, lower RH	BN4, BN6, BN7, BT7, BJ7, BJ8	1
KA333AH/BN4-L	Rep.-Blech Türhaut unten LH	skin repair, lower LH	BN4, BN6, BN7, BT7, BJ7, BJ8	1
KA334AH/BJ7-R	Rep.-Blech Türrahmen unten RH	frame repair, lower RH	BJ7	1
KA334AH/BJ7-L	Rep.-Blech Türrahmen unten LH	frame repair, lower LH	BJ7	1
KA334AH/BJ8-L	Rep.-Blech Türrahmen unten LH	frame repair, lower LH	BJ8	1
KA334AH/BJ8-R	Rep.-Blech Türrahmen unten RH	frame repair, lower RH	BJ8	1
KA336AH/R	Rep.-Blech hinterer Kotflügel, vorne RH	rear fender repair, front RH	BN4, BN6, BN7, BT7, BJ7, BJ8	1
KA336AH/L	Rep.-Blech hinterer Kotflügel, vorne LH	rear fender repair, front LH	BN4, BN6, BN7, BT7, BJ7, BJ8	1
KA338AH/BN4	Nase Frontblech	shroud nose panel	BN4, BN6, BN7, BT7, BJ7, BJ8 < 76137	1
KA338AH/BJ8	Nase Frontblech	shroud nose panel	BJ8 > 76138	1
KA342AH/L	Rep.-Blech hinterer Kotflügel hinten LH	rear fender repair, rear LH	BN4, BN6, BN7, BT7, BJ7, BJ8	1
KA342AH/R	Rep.-Blech hinterer Kotflügel hinten RH	rear fender repair, rear RH	BN4, BN6, BN7, BT7, BJ7, BJ8	1
KA401AH/R	Kotflügel vorne rechts	front fender, RH	BN4, BN6, BN7, BT7, BJ7, BJ8	1
KA401AH/L	Kotflügel vorne links	front fender, LH	BN4, BN6, BN7, BT7, BJ7, BJ8	1
KA403AH	Halter Kotflügel vorne	bracket, front fender support	BN4, BN6, BN7, BT7, BJ7, BJ8	2
KA404AH	Luftschlitze vorne, Paar (ohne Kante)	vent pair	BN4, BN6, BN7, BT7, BJ7, BJ8	1
KA405AH/R-ALU	Kotflügel Alu. vorne rechts	front fender, aluminum RH	BN4, BN6, BN7, BT7, BJ7, BJ8	1
KA405AH/L-ALU	Kotflügel Alu. vorne links	front fender, aluminum LH	BN4, BN6, BN7, BT7, BJ7, BJ8	1
KA405AH/L-A+S	Kotflügel Alu. vorne links mit Lüftungsschlitzen	front fender, aluminum LH with vents	BN4, BN6, BN7, BT7, BJ7, BJ8	1
KA405AH/R-A+S	Kotflügel Alu. vorne rechts mit Lüftungsschlitzen	front fender, aluminum RH with vents	BN4, BN6, BN7, BT7, BJ7, BJ8	1
KA411AH	Schrauben-Satz Kotflügel vorne	fitting kit, front fender	BN4, BN6, BN7, BT7, BJ7, BJ8	2
KA414AH/R	Kotflügel hinten rechts	rear fender RH	BN4, BN6, BN7, BT7, BJ7, BJ8	1
KA414AH/L	Kotflügel hinten links	rear fender LH	BN4, BN6, BN7, BT7, BJ7, BJ8	1
KA414AH/R-ALU	Kotflügel hinten rechts Aluminium	rear fender, aluminum RH	BN4, BN6, BN7, BT7, BJ7, BJ8	1
KA414AH/L-ALU	Kotflügel hinten links Aluminium	rear fender, aluminum LH	BN4, BN6, BN7, BT7, BJ7, BJ8	1
KA420AH	Schrauben-Satz Kotflügel hinten	fitting kit, rear fender	BN4, BN6, BN7, BT7, BJ7, BJ8	2
KA421AH/BN4	Kofferraum-Deckel	trunk lid	BN4, BN6, BN7, BT7, BJ7, BJ8	1
KA421AH/BN4-A	Kofferraum-Deckel Aluminium	trunk lid, aluminum	BN4, BN6, BN7, BT7, BJ7, BJ8	1
KA421AAH	Rep.-Blech Kofferraumdeckel	trunk lid repair panel	BN4, BN6, BN7, BT7, BJ7, BJ8	1

Karosserie / Inner Body Panels BN1-BN2

Befestigungsteile s. auch S. 169 Verdecke, Verdeckabdeckung / Fittings please refer page 169, chapter: hood, tonneau cover

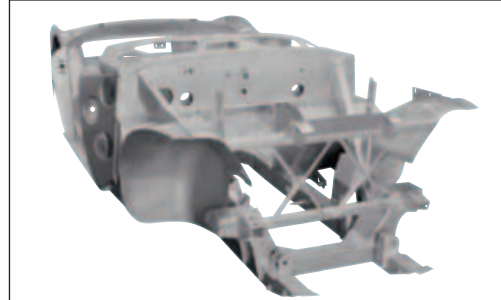
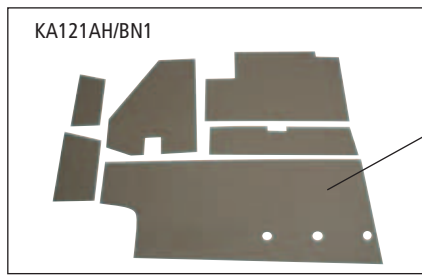
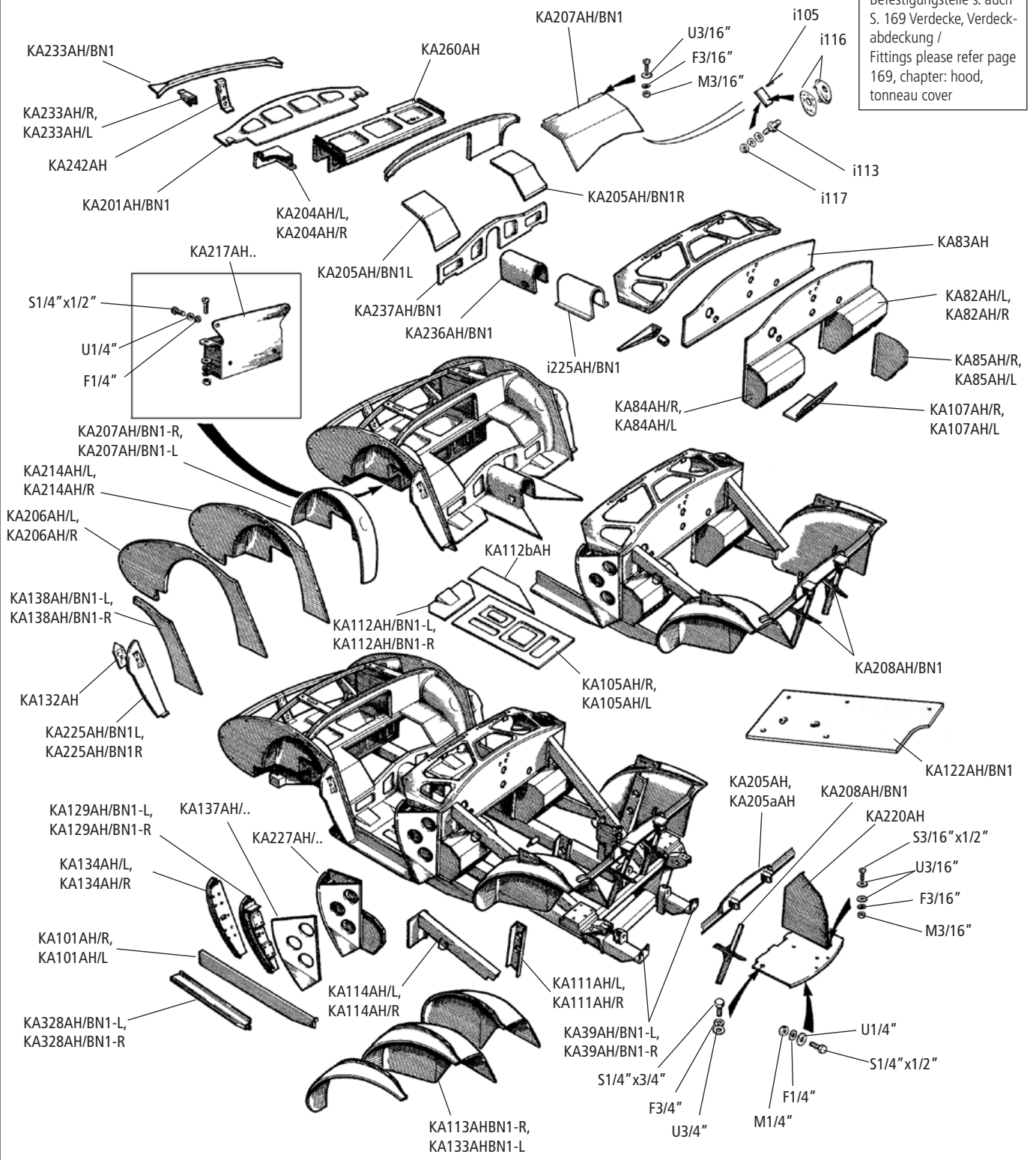

No.	Bezeichnung	Description	Type	Anzahl/Req.
KA39AH/BN1-L	Halter Frontmaske links	bracket, shroud LH	BN1-BN2	1
KA39AH/BN1-R	Halter Frontmaske rechts	bracket, shroud RH	BN1-BN2	1
KA82AH/L	Fußraum-Einheit links	full footwell floor LH	BN1-BN2	1
KA82AH/R	Fußraum-Einheit rechts	full footwell floor RH	BN1-BN2	1
KA83AH	Trennwand Fahrer- zu Motorraum	bulkhead repair panel	BN1-BN2	1
KA84AH/R	Blech seitl. Fußraum außen rechts	outer side panel, RH	BN1-BN2	1
KA84AH/L	Blech seitl. Fußraum außen links	outer side panel, LH	BN1-BN2	1
KA85AH/L	Blech seitl. Fußraum innen links	inner side panel, RH	BN1-BN2	1
KA85AH/R	Blech seitl. Fußraum innen rechts	inner side panel, LH	BN1-BN2	1
KA101AH/R	Mittlerer Schweller rechts	inner sill assembly RH	BN1-BN2	1
KA101AH/L	Mittlerer Schweller links	inner sill assembly LH	BN1-BN2	1
KA105AH/L	Bodenblech links	floor panel LH	BN1-BN2	1
KA105AH/R	Bodenblech rechts	floor panel RH	BN1-BN2	1
KA107AH/L	Bodenblech Rep.-Blech vorne links	toeboard repair LH	BN1-BN2	1
KA107AH/R	Bodenblech Rep.-Blech vorne rechts	toeboard repair RH	BN1-BN2	1
KA111AH/L	Verstärkung Radkasten links	channel, inner guard to shroud support channel LH	BN1-BN2	1
KA111AH/R	Verstärkung Radkasten rechts	channel, inner guard to shroud support channel RH	BN1-BN2	1
KA112AH/BN1L	Bodenblech hinten links	floor section, rear LH	BN1-BN2	1
KA112AH/BN1R	Bodenblech hinten rechts	floor section rear RH	BN1-BN2	1
KA112bAH	Bodenblech hinten mitte	floor section center	BN1-BN2	2
KA113AH/BN1-R	Radlauf innen vorne rechts	wheel arch assembly RH	BN1-BN2	1
KA113AH/BN1-L	Radlauf innen vorne links	wheel arch assembly LH	BN1-BN2	1
KA114AH/L	Spritzwand Abstützung links	bulkhead support assembly LH	BN1-BN2	1
KA114AH/R	Spritzwand Abstützung rechts	bulkhead support assembly RH	BN1-BN2	1
KA121AH/BN1	Hitzeschild Satz, Linkslenker	heat shield, set, LHD	BN1-BN2	1
KA121AH/BN1RH	Hitzeschild Satz, Rechtslenker	heat shield, set, RHD	BN1-BN2	1
KA122AH/BN1	Hitzeschild Bodenblech, separat * (* ist im Satz KA121AH/BN1 enthalten)	heat shield, bottom plate, separate * (included in set KA121AH/BN1)	BN1-BN2	1
KA129AH/BN1-L	A-Säule links	hinge pillar assembly LH	BN1 < 5000	1
KA129AH/BN1-R	A-Säule rechts	hinge pillar assembly RH	BN1 < 5000	1
KA132AH	Gewindeplatte Fanghaken	triangle box, shut pillar	BN1-BN2	2
KA134AH/L	Rep.-Blech A-Säule links	hinge pillar repair LH	BN1 > 5001, BN2	1
KA134AH/R	Rep.-Blech A-Säule rechts	hinge pillar repair RH	BN1 > 5001, BN2	1
KA137AH/L	Verstärkung A-Säule vorne links	side reinforcement LH	BN1 > 5001, BN2	1
KA137AH/R	Verstärkung A-Säule vorne rechts	side reinforcement RH	BN1 > 5001, BN2	1
KA137AH/BN1-R	Verstärkung A-Säule vorne rechts	side reinforcement RH	BN1 < 5000	1
KA137AH/BN1-L	Verstärkung A-Säule vorne links	side reinforcement LH	BN1 < 5000	1
KA138AH/BN1-L	Rep-Blech Innenkotflügel hinten links	repair panel, front LH	BN1-BN2	1
KA138AH/BN1-R	Rep-Blech Innenkotflügel hinten rechts	repair panel, front RH	BN1-BN2	1
KA201AH/BN1	Kofferraum-Boden	trunk floor	BN1-BN2	1
KA204AH/L	Seitenblech Kofferraum links	inner trunk box repair LH	BN1-BN2	1
KA204AH/R	Seitenblech Kofferraum rechts	inner trunk box repair RH	BN1-BN2	1
KA205AH/BN1L	Abdeckblech Hinterachse links	axle cover panel LH	BN1-BN2	1
KA205AH/BN1R	Abdeckblech Hinterachse rechts	axle cover panel RH	BN1-BN2	1
KA205AH	Motorhauben-Auflage mit Scharnier-Vorrichtung	hood hinge brace assembly with hinge brackets	BN1-BN2	1
KA205aAH	Motorhauben-Auflage ohne Scharnier-Vorrichtung	hood hinge brace assembly w/o hinge brackets	BN1-BN2	1
KA206AH/L	Innenkotflügel hinten links	inner quarter panel LH	BN1-BN2	1
KA206AH/R	Innenkotflügel hinten rechts	inner quarter panel RH	BN1-BN2	1
KA207AH/BN1	Abdeckblech Batterie	battery access panel	BN1-BN2	1
KA207AH/BN1-R	Radlauf innen rechts hinten	rear wheel arch RH	BN1-BN2	1
KA207AH/BN1-L	Radlauf innen links hinten	rear wheel arch LH	BN1-BN2	1
KA208AH/BN1	Abstützung Querverbindung Motorhaube (Paar)	cross brace assembly, pair	BN1-BN2	1
KA214AH/L	Innenkotflügel/Radlauf hinten links	inner panel & wheel arch assembly LH	BN1-BN2	1
KA214AH/R	Innenkotflügel/Radlauf hinten rechts	inner panel & wheel arch assembly RH	BN1-BN2	1
KA217AH	Blech Anschlaggummi	bump stop box	BN1 > 221536 - BN2	2
KA217AH/BN1	Blech Anschlaggummi	bump stop box	BN1 < 221535	2
KA220AH	Trennblech	apron panel	BN1-BN2	1
i225AH/BN1	Getriebetunnel GFK	drive shaft tunnel GFK	BN1	1
i225AH/BN2	Getriebetunnel GFK	drive shaft tunnel GFK	BN2	1

Karosserie / Inner Body Panels BN1-BN2

Befestigungsteile s. auch S. 169 Verdecke, Verdeckabdeckung / Fittings please refer page 169, chapter: hood, tonneau cover

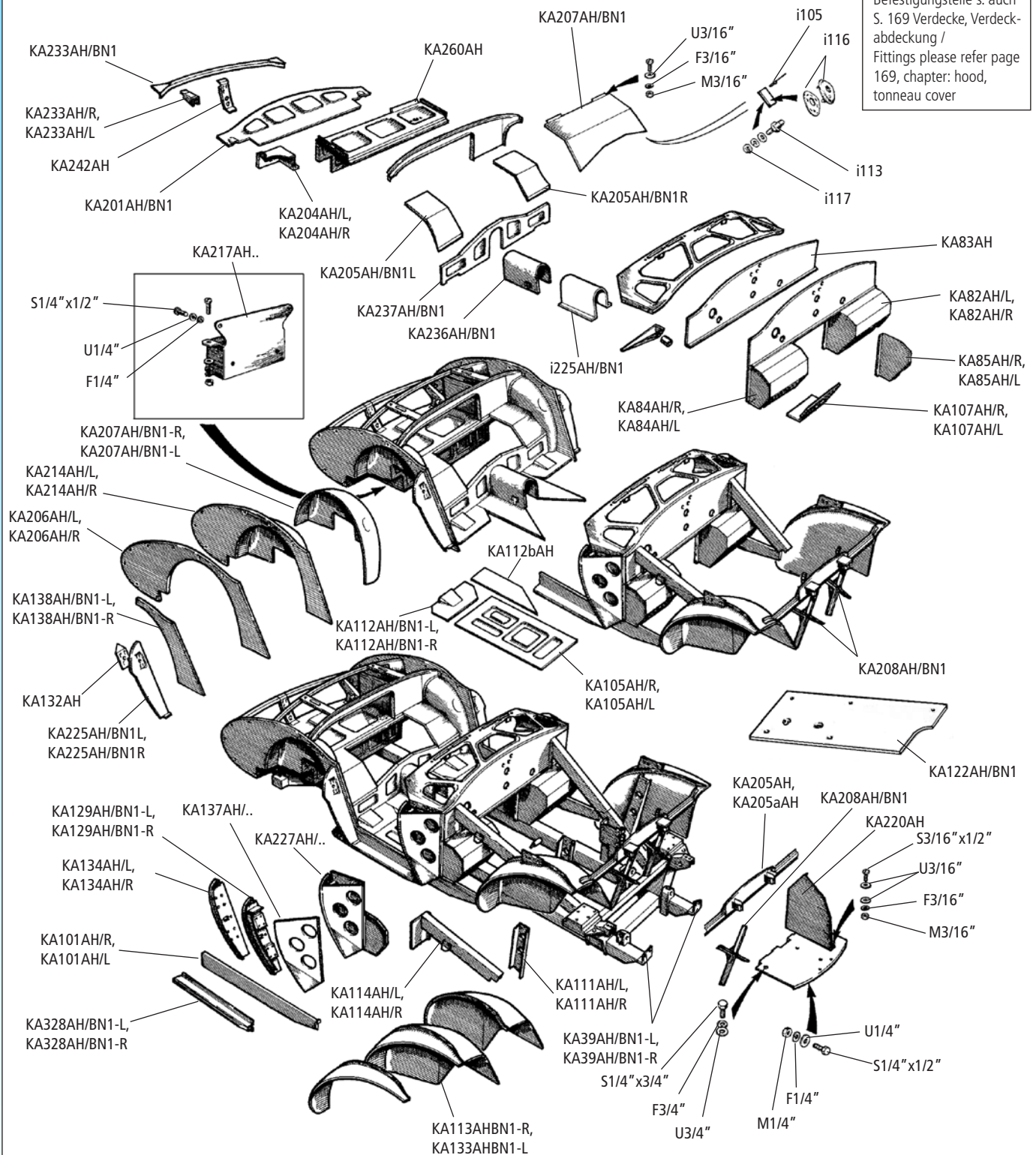

KA121AH/BN1

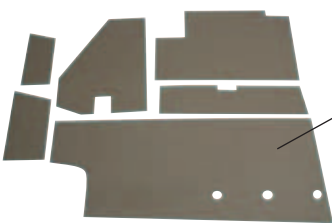

KA122AH/BN1

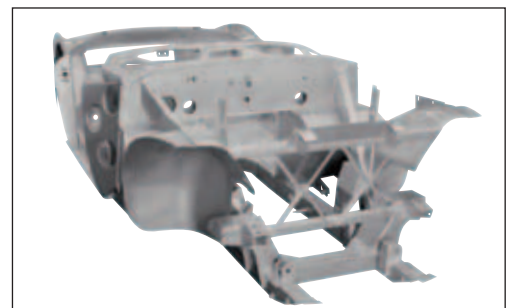

No.	Bezeichnung	Description	Type	Anzahl/Req.
KA225AH/BN1L	Türsäule hinten links	shut pillar assembly LH	BN1-BN2	1
KA225AH/BN1R	Türsäule hinten rechts	shut pillar assembly RH	BN1-BN2	1
KA227AH/L	Fußraumseite links	scuttle side panel assembly LH	BN1 > 5001, BN2 < 10030	1
KA227AH/R	Fußraumseite rechts	scuttle side panel assembly RH	BN1 > 5001, BN2 < 10030	1
KA227AH/BN1-L	Fußraumseite links	scuttle side panel assembly LH	BN1 < 5000	1
KA227AH/BN1-R	Fußraumseite rechts	scuttle side panel assembly RH	BN1 < 5000	1
KA227AH/BN2-L	Blech Fußraumseite links	scuttle side panel assembly LH	BN2 > 10031	1
KA227AH/BN2-R	Blech Fußraumseite rechts	scuttle side panel assembly RH	BN2 > 10031	1
KA233AH/BN1	Halter Heckmaske	rear skirt rail assembly	BN1-BN2	1
KA233AH/R	Verstärkung Heckschürze rechts	support, bumper bracket to rear skirt RH	BN1-BN2	1
KA233AH/L	Verstärkung Heckschürze links	support, bumper bracket to rear skirt LH	BN1-BN2	1
KA236AH/BN1	Getriebetunnel hinten	drive shaft tunnel, rear	BN1-BN2	1
KA237AH/BN1	Stehblech hinter den Sitzen	heel board, rear, full width	BN1-BN2	1
KA242AH	Halteblech Kofferraumfanhaken	support, rear skirt rail	BN1-BN2	1
KA260AH	Kofferraumbücke	main axle cover	BN1-BN2	1
KA328AH/BN1-L	Türschweller aussen links	rocker panel LH	BN1-BN2	1
KA328AH/BN1-R	Türschweller aussen rechts	rocker panel RH	BN1-BN2	1

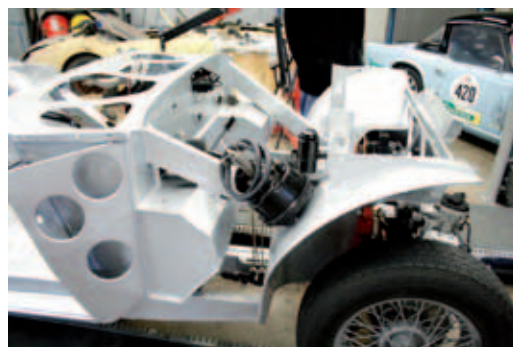

Karosserie / Inner Body Panels BN4, BN6, BN7, BT7, BJ7, BJ8

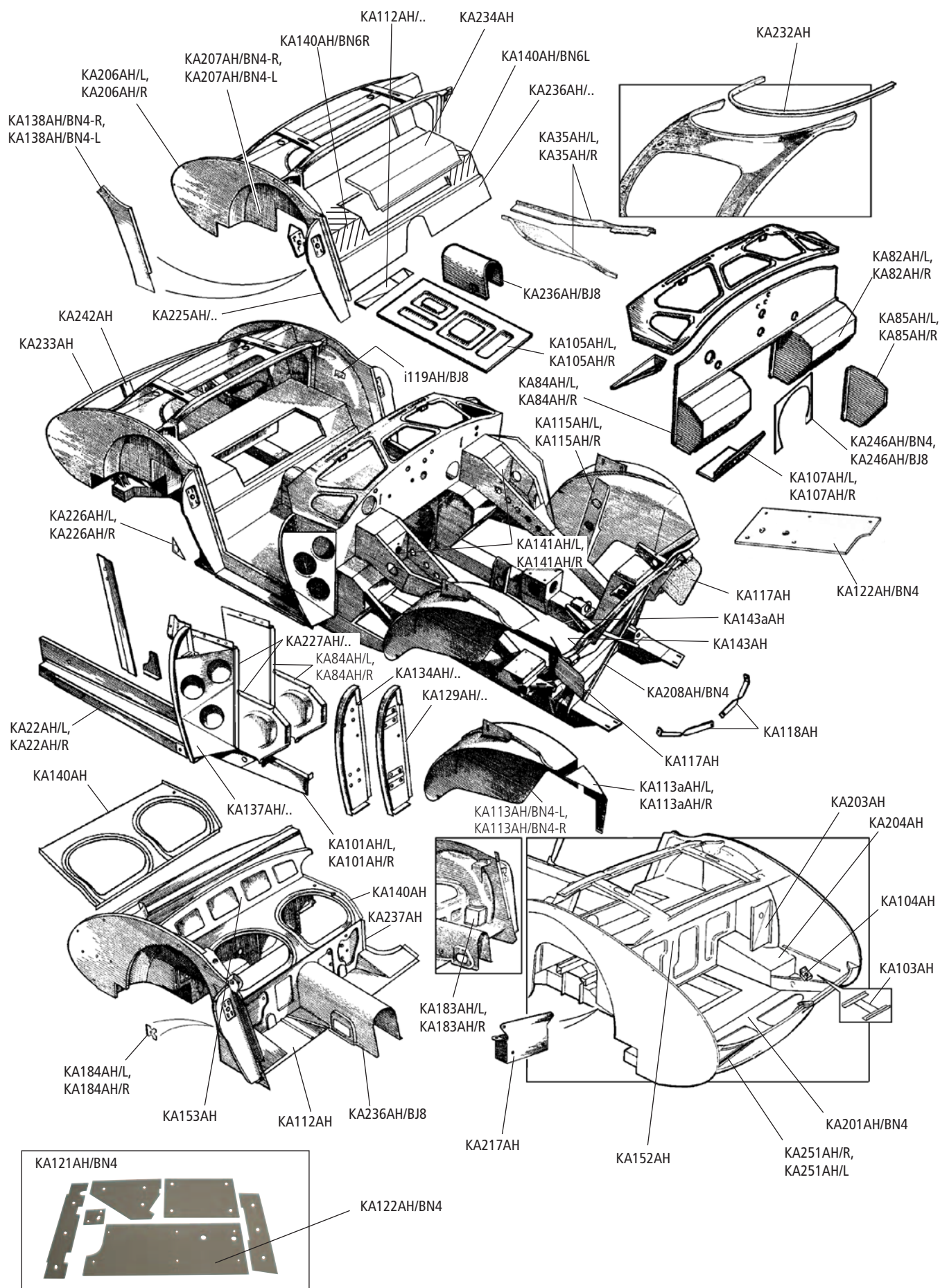

No.	Bezeichnung	Description	Type	Anzahl/Req.
KA22AH/L	Innenschweller links	rocker panel LH	BN4, BN6, BN7, BT7, BJ7, BJ8	1
KA22AH/R	Innenschweller rechts	rocker panel RH	BN4, BN6, BN7, BT7, BJ7, BJ8	1
KA35AH/L	Blech Getriebe seitlich links	edge kit, gearbox cover LH	BJ7, BJ8	1
KA35AH/R	Blech Getriebe seitlich rechts	edge kit, gearbox cover RH	BJ7, BJ8	1
KA82AH/L	Fußraum-Einheit links	full footwell floor LH	BN4, BN6, BN7, BT7, BJ7, BJ8	1
KA82AH/R	Fußraum-Einheit rechts	full footwell floor RH	BN4, BN6, BN7, BT7, BJ7, BJ8	1
KA84AH/R	Blech seitl. Fußraum außen rechts	outer side panel, RH	BN4, BN6, BN7, BT7, BJ7, BJ8	1
KA84AH/L	Blech seitl. Fußraum außen links	outer side panel, LH	BN4, BN6, BN7, BT7, BJ7, BJ8	1
KA85AH/L	Blech seitl. Fußraum innen links	inner side panel, RH	BN4, BN6, BN7, BT7, BJ7, BJ8	1
KA85AH/R	Blech seitl. Fußraum innen rechts	inner side panel, LH	BN4, BN6, BN7, BT7, BJ7, BJ8	1
KA101AH/L	Mittlerer Schweller links	inner sill assembly LH	BN4, BN6, BN7, BT7, BJ7, BJ8	1
KA101AH/R	Mittlerer Schweller rechts	inner sill assembly RH	BN4, BN6, BN7, BT7, BJ7, BJ8	1
KA103AH	Halter Batterie Sockelstütze	bracket, battery base support	BN4, BN6, BN7, BT7, BJ7, BJ8	1
KA104AH	Halter Batterieschalter	bracket, battery switch	BN4, BN6, BN7, BT7, BJ7, BJ8	1
KA105AH/L	Bodenblech links	floor panel LH	BN4, BN6, BN7, BT7, BJ7, BJ8	1
KA105AH/R	Bodenblech rechts	floor panel RH	BN4, BN6, BN7, BT7, BJ7, BJ8	1
KA107AH/R	Bodenblech Rep.-Blech vorne rechts	toe board, front floor RH	BN4, BN6, BN7, BT7, BJ7, BJ8	1
KA107AH/L	Bodenblech Rep.-Blech vorne links	toe board, front floor LH	BN4, BN6, BN7, BT7, BJ7, BJ8	1
KA112AH/BN4L	Bodenblech hinten links	floor section, rear LH	BN4,BT7,BJ7-BJ8 < 26704	1
KA112AH/BN4R	Bodenblech hinten rechts	floor section, rear RH	BN4,BT7,BJ7-BJ8 < 26704	1
KA112AH/BJ8R	Bodenblech hinten rechts	floor section, rear RH	BJ8 > 26705	1
KA112AH/BJ8L	Bodenblech hinten links	floor section, rear LH	BJ8 > 26705	1
KA113AH/BN4-L	Radlauf innen vorne links	wheel arch LH	BN4, BN6, BN7, BT7, BJ7, BJ8	1
KA113AH/BN4-R	Radlauf innen vorne rechts	wheel arch RH	BN4, BN6, BN7, BT7, BJ7, BJ8	1
KA113aAH/L	Verlängerung Radlauf innen links	extension, inner guard LH	BN4, BN6, BN7, BT7, BJ7, BJ8	1
KA113aAH/R	Verlängerung Radlauf innen rechts	extension, inner guard RH	BN4, BN6, BN7, BT7, BJ7, BJ8	1
KA115AH/R	Verstärkung Radkasten innen rechts	channel, shroud support RH	BN4, BN6, BN7, BT7, BJ7, BJ8	1
KA115AH/L	Verstärkung Radkasten innen links	channel, shroud support LH	BN4, BN6, BN7, BT7, BJ7, BJ8	1
KA117AH	Spritzblech vorne Paar	splash panel set (pair)	BN4, BN6, BN7, BT7, BJ7, BJ8	1
KA118AH	Halter Paar	steady bracket pair	BN7, BT7	1
i119AH/BJ8	Sicherheitsgurt Befestigung	seat belt mounting, rear	BN4, BN6, BN7, BT7, BJ7, BJ8	2
KA121AH/BN4	Hitzeschild Satz	heat shield set	BN4, BN6, BN7, BT7, BJ7, BJ8	1
KA122AH/BN4	Hitzeschild Bodenblech, separat * (* ist im Satz KA121AH/BN4 enthalten)	heat shield, bottom plate, separate * (* included in set KA121AH/BN4)	BN4, BN6, BN7, BT7, BJ7, BJ8	1
KA129AH/BN4-R	A-Säule rechts	hinge pillar assembly RH	BN4, BN6, BN7, BT7	1
KA129AH/BN4-L	A-Säule links	hinge pillar assembly LH	BN4, BN6, BN7, BT7	1
KA129AH/BJ7-L	A-Säule links	hinge pillar assembly LH	BJ7, BJ8	1
KA129AH/BJ7-R	A-Säule rechts	hinge pillar assembly RH	BJ7, BJ8	1
KA134AH/BN4-R	Rep.-Blech A-Säule rechts	hinge pillar repair RH	BN4, BN6, BN7, BT7	1
KA134AH/BN4-L	Rep.-Blech A-Säule links	hinge pillar repair LH	BN4, BN6, BN7, BT7	1
KA134AH/BJ7-R	Rep.-Blech A-Säule rechts	hinge pillar repair RH	BJ7, BJ8	1
KA134AH/BJ7-L	Rep.-Blech A-Säule links	hinge pillar repair LH	BJ7, BJ8	1
KA137AH/R	Verstärkung A-Säule vorne rechts	side reinforcement RH	BN4, BN6, BN7, BT7	1
KA137AH/L	Verstärkung A-Säule vorne links	side reinforcement LH	BN4, BN6, BN7, BT7	1
KA137AH/BJ7-L	Verstärkung A-Säule vorne links	side reinforcement LH	BJ7, BJ8	1
KA137AH/BJ7-R	Verstärkung A-Säule vorne rechts	side reinforcement RH	BJ7, BJ8	1
KA138AH/BN4-R	Rep-Blech Innenkotflügel hinten rechts	front repair RH	BN4, BN6, BN7, BT7, BJ7, BJ8	1
KA138AH/BN4-L	Rep-Blech Innenkotflügel hinten links	front repair LH	BN4, BN6, BN7, BT7, BJ7, BJ8	1
KA140AH	Umrandung Sitzschalen hinten	rear seat surround panel	BN4, BN6, BN7, BT7, BJ7, BJ8	1
KA140AH/BN6L	Blech neben Batterieabdeckung LH	cover, battery access LH	BN6, BN7	1
KA140AH/BN6R	Blech neben Batterieabdeckung RH	cover, battery access RH	BN6, BN7	1
KA141AH/L	Pedalkasten links	pedal box accommodation LH	BN4, BN6, BN7, BT7, BJ7, BJ8	1
KA141AH/R	Pedalkasten rechts	pedal box accommodation RH	BN4, BN6, BN7, BT7, BJ7, BJ8	1
KA143AH	Halteblech Kühler oben	cross brace upper panel	BN4, BN6, BN7, BT7, BJ7, BJ8	1
KA143aAH	Halter Kühler Paar	bracket set, radiator steady	BN4, BN6, BN7, BT7, BJ7, BJ8	1
KA152AH	Stehblech Kofferraum unten	rear bulkhead	BN4, BN6, BN7, BT7, BJ7, BJ8	1
KA183AH/R	Kasten Ausschnitt Schubstrebe rechts	box and gusset, radius arm RH	BJ8 > 26705	1
KA183AH/L	Kasten Ausschnitt Schubstrebe links	box and gusset, radius arm LH	BJ8 > 26705	1

- Fortsetzung s. nächste Seite

- to be continued on next page

Karosserie / Inner Body Panels BN4, BN6, BN7, BT7, BJ7, BJ8

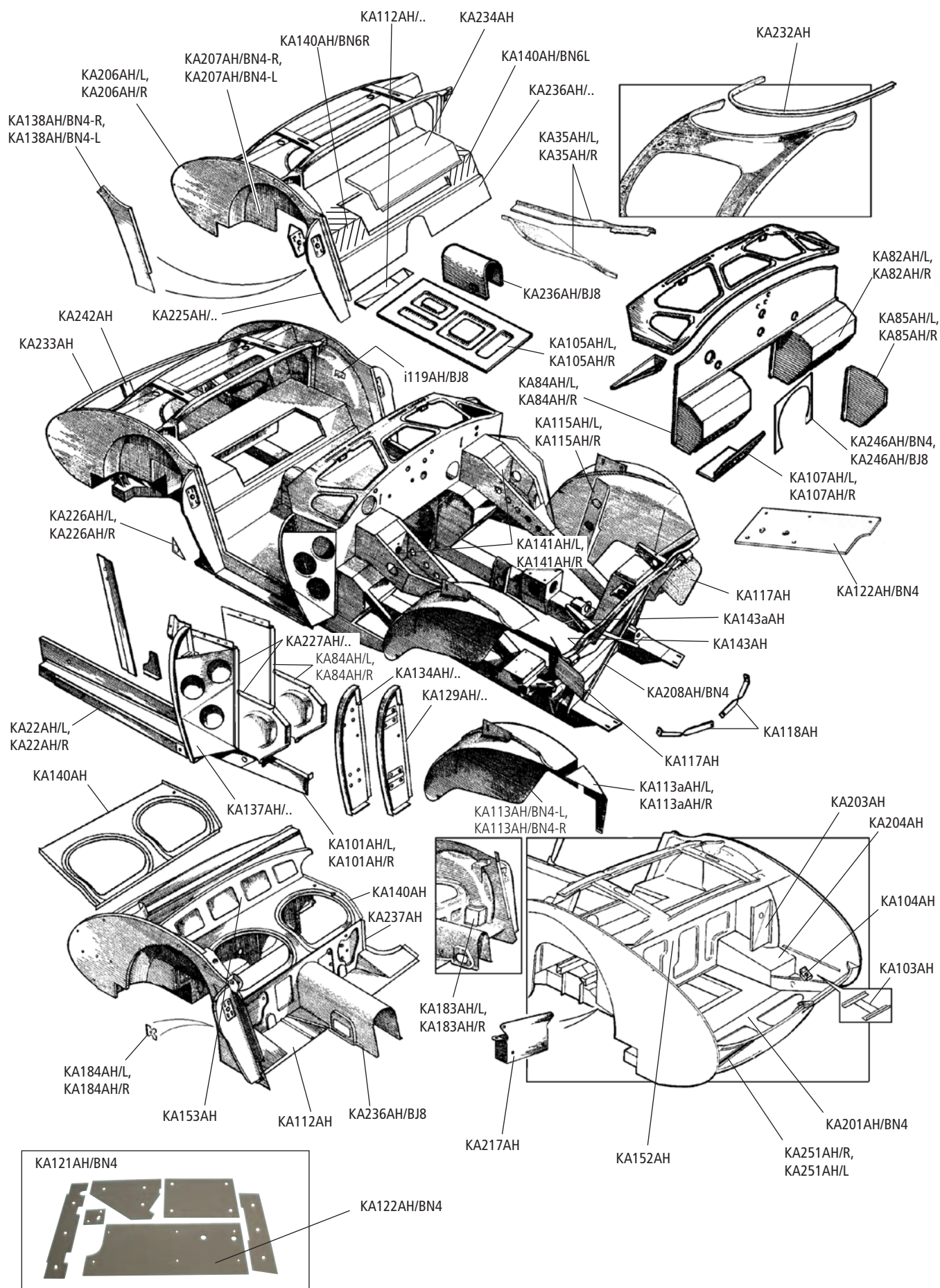

No.	Bezeichnung	Description	Type	Anzahl/Req.
KA184AH/R	Befestigung Schubstrebe rechts	mounting, radius arm RH	BJ8 > 26705	1
KA184AH/L	Befestigung Schubstrebe links	mounting, radius arm LH	BJ8 > 26705	1
KA201AH/BN4	Kofferraum-Boden	trunk floor	BN4, BN6, BN7, BT7, BJ7, BJ8	1
KA203AH	Blech unter Batteriekasten	battery cable panel	BN4, BN6, BN7, BT7, BJ7, BJ8	1
KA204AH/L	Seitenblech Kofferraum links	trunk side box LH	BN4, BN6, BN7, BT7, BJ7, BJ8	1
KA204AH/R	Seitenblech Kofferraum rechts	trunk side box RH	BN4, BN6, BN7, BT7, BJ7, BJ8	1
KA208AH/BN4	Abstützung Querverbindung Motorhaube (Paar)	cross brace assembly (pair)	BN4, BN6, BN7, BT7, BJ7, BJ8	1
KA206AH/L	Innenkotflügel hinten links	rear quarter LH	BN4, BN6, BN7, BT7, BJ7, BJ8	1
KA206AH/R	Innenkotflügel hinten rechts	rear quarter RH	BN4, BN6, BN7, BT7, BJ7, BJ8	1
KA207AH/BN4-L	Radlauf innen hinten links	wheel arch LH	BN4, BN6, BN7, BT7, BJ7, BJ8	1
KA207AH/BN4-R	Radlauf innen hinten rechts	wheel arch RH	BN4, BN6, BN7, BT7, BJ7, BJ8	1
KA217AH	Blech Anschlaggummi	bump stop box	BN4, BN6, BN7, BT7, BJ7, BJ8 < 26704	2
KA217AH/BJ8	Blech Anschlaggummi	bump stop box	BJ8 > 26705	2
KA225AH/BN4R	Türsäule hinten rechts	shut pillar assembly RH	BN4, BN6, BN7, BT7	1
KA225AH/BN4L	Türsäule hinten links	shut pillar assembly LH	BN4, BN6, BN7, BT7	1
KA225AH/BJ7R	Türsäule hinten rechts	shut pillar assembly RH	BJ7, BJ8	1
KA225AH/BJ7L	Türsäule hinten links	shut pillar assembly LH	BJ7, BJ8	1
KA226AH/R	Verstärkung B-Säule/Schweller rechts	gusset, pillar to sill RH	BN4, BN6, BN7, BT7, BJ7, BJ8	1
KA226AH/L	Verstärkung B-Säule/Schweller links	gusset, pillar to sill LH	BN4, BN6, BN7, BT7, BJ7, BJ8	1
KA227AH/BN4-R	Fussraumseite rechts	scuttle side assembly RH	BN4, BN6, BN7, BT7	1
KA227AH/BN4-L	Fussraumseite links	scuttle side assembly LH	BN4, BN6, BN7, BT7	1
KA227AH/BJ7-R	Fussraumseite rechts	scuttle side assembly RH	BJ7, BJ8	1
KA227AH/BJ7-L	Fussraumseite links	scuttle side assembly LH	BJ7, BJ8	1
KA232AH	Regenlaufrinne Dach	drainage channel	BJ7, BJ8	1
KA233AH	Halterleiste Heckmaske inkl. Halter li. und re.	rear skirt rail assembly LH & RH	BN4, BN6, BN7, BT7, BJ7, BJ8	1
KA234AH	Abdeckung Batteriezugang	cover, battery access	BN6, BN7	1
KA236AH/BJ8	Getriebetunnel hinten	driveshaft tunnel, rear	BN4, BN6, BN7, BT7, BJ7, BJ8	1
KA237AH/BN4	Stehblech hinten	heel board repair, rear	BN4, BT7, BJ7, BJ8 < 26704	1
KA237AH/BN6	Stehblech hinten	heel board repair, rear	BN6	1
KA237AH/BJ8	Stehblech hinten ganze Breite	heel board, full width	BJ8 > 26705	1
KA242AH	Halteblech Kofferraumfanghaken	support, rear skirt rail	BN4, BN6, BN7, BT7, BJ7, BJ8	1
KA246AH/BN4	Verstärkung Getriebetunnel	reinforcement panel	BN4, BN6, BN7 < 16038, BT7 < 15880	1
KA246AH/BJ8	Verstärkung Getriebetunnel	reinforcement panel	BN7 > 16039, BT7 > 15881, BJ7, BJ8	1
KA251AH/R	Halteblech rechts für KA233AH	support, trunk lip RH to no. KA233AH	BN4, BN6, BN7, BT7, BJ7, BJ8	1
KA251AH/L	Halteblech links für KA233AH	support, trunk lip LH to no. KA233AH	BN4, BN6, BN7, BT7, BJ7, BJ8	1

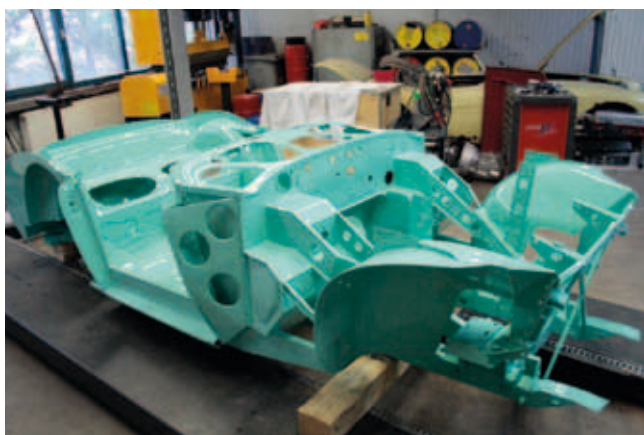

Restoration: Impressionen / restoration impressions

BN1-BN2

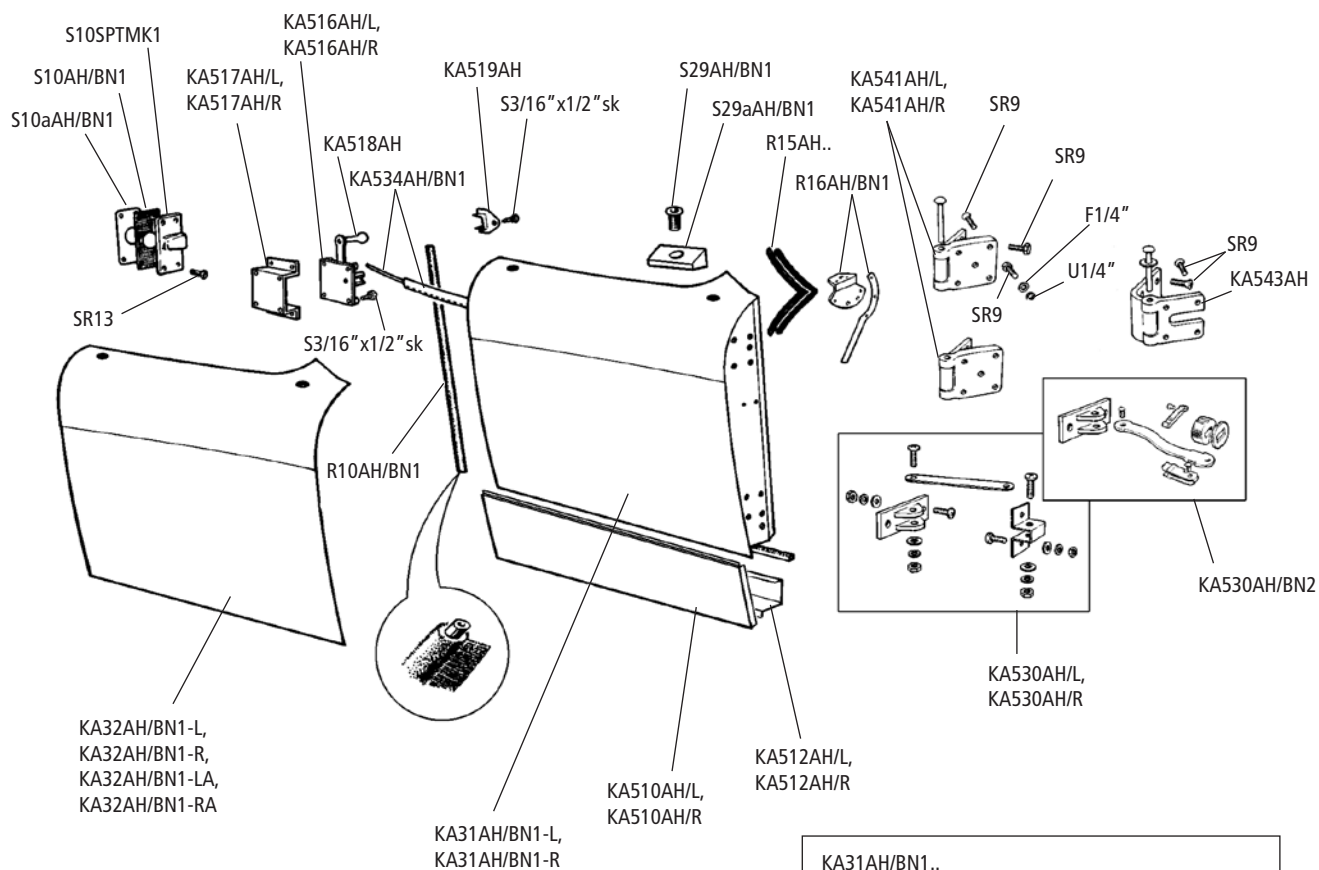

KA31AH/BN1..

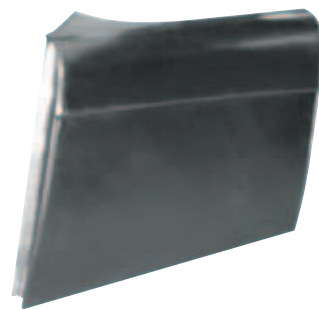

No.	Bezeichnung	Description	Type	Anzahl/Req.
SR9	Senkkopfschraube	countersunk screw, hinge to door	BN1-BN2	A/R
SR13	Schraube	screw	BN1-BN2	8
S10SPTMK1	Türfangplatte an B-Säule	striker assembly, door lock	BN1 > 2236, BN2	2
S10aAH/BN1	Unterlage Türfangplatte	plate, tapped	BN1 > 2236, BN2	2
S10AH/BN1	Dichtung Türfangplatte	plate, packing	BN1 > 2236, BN2	2
R10AH/BN1	Türdichtgummi schwarz	draft seal, black	BN1-BN2	A/R
R15AH/BN1	Gummiset Türecke vorne (2 Stk.)	seal, set, door to scuttle (2 pc.)	BN1-BN2 < 11142	1
R15AH	Gummiset Türecke vorne (2 Stk.)	seal, set, door to scuttle (2 pc.)	BN2 > 11143	1
R16AH/BN1	Halte-Satz Gummi Spritzwand	bracket set, scuttle seal	BN2 > 11143	1
S29aAH/BN1	Paar Holzblöcke / Hülse Fenster	wooden block pair, securing windscreen socket	BN1-BN2	2
S29AH/BN1	Chrom-Hülse Steckfenster	socket, side sreen	BN1-BN2	4
KA31AH/BN1-L	Türe links	door shell, assembly, LH	BN1-BN2	1
KA31AH/BN1-R	Türe rechts	door shell, assembly, RH	BN1-BN2	1
KA32AH/L	Türhaut links	door skin, steel LH	BN1-BN2	1
KA32AH/R	Türhaut rechts	door skin, steel RH	BN1-BN2	1
KA32AH/RA	Türhaut rechts Aluminium	door skin, aluminum RH	BN1-BN2	1
KA32AH/LA	Türhaut links Aluminium	door skin, aluminum LH	BN1-BN2	1
KA510AH/L	Reparaturblech Türausenhaut unten links	skin repair, lower LH	BN1-BN2	1
KA510AH/R	Reparaturblech Türausenhaut unten rechts	skin repair, lower RH	BN1-BN2	1
KA512AH/R	Reparaturblech Tür unten/rechts	frame repair, lower RH	BN1-BN2	1
KA512AH/L	Reparaturblech Tür unten/links	frame repair, lower LH	BN1-BN2	1
KA515AH/BN1-L	Türschliessmechanismus links	door lock assembly LH	BN1-BN2	1
KA515AH/BN1-R	Türschliessmechanismus rechts	door lock assembly RH	BN1-BN2	1
KA517AH/L	Gehäuse Türschlieβmechan. LH	bracket, lock mounting LH	BN1-BN2	1
KA517AH/R	Gehäuse Türschlieβmechan. RH	bracket, lock mounting RH	BN1-BN2	1
KA518AH	Knopf Türschlieβmechanismus	knob, door lock	BN1-BN2	2
KA519AH	Anschlagplatte Türschloss	catch plate, lock	BN1-BN2	2
KA530AH/L	Türfangband links	door check assembly LH	BN1 < 5000	1
KA530AH/R	Türfangband rechts	door check assembly RH	BN1 < 5000	1
KA530AH/BN2	Türfangband	door check assembly	BN1 > 5001 - BN2	2
KA534AH/BN1	Zugkabel Türöffner	cable & covering	BN1-BN2	2
KA541AH/R	Türscharniere Paar rechts	door hinge pair RH	BN1 < 5000	1
KA541AH/L	Türscharniere Paar links	door hinge pair LH	BN1 < 5000	1
KA543AH	Türscharnier	door hinge	BN1 > 5001 - BN2	4
S3/16"X3/4"SK	Senkkopfschraube 3/16" x 3/4"	screw	BN1-BN2	A/R

BN4, BN6, BN7, BT7

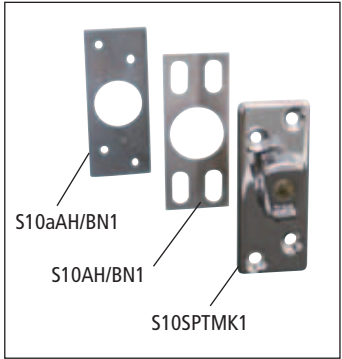
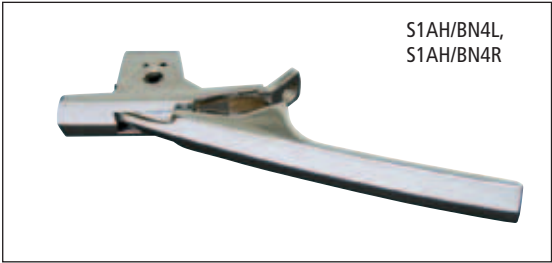
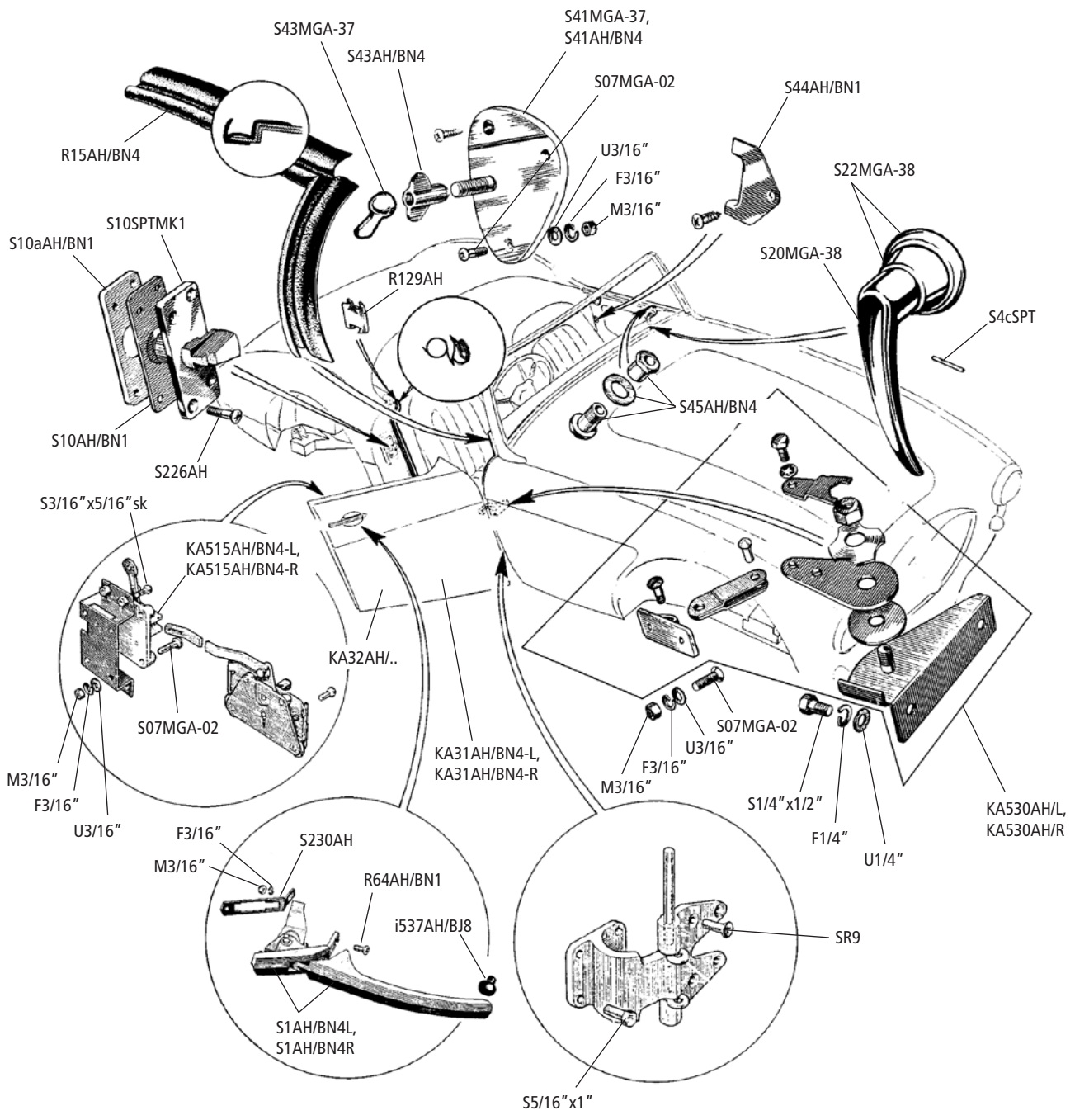

No.	Bezeichnung	Description	Type	Anzahl/Req.
S1AH/BN4L	Türgriff links	door handle LH	BN4, BN6, BN7, BT7	1
S1AH/BN4R	Türgriff rechts	door handle RH	BN4, BN6, BN7, BT7	1
S4cSPT	Befestigungsstift Fensterkurbel	pin, handle securing	BN4, BN6, BN7, BT7	2
S07MGA-02	Senkkopfschraube	countersunk screw	BN4, BN6, BN7, BT7	A/R
SR9	Senkkopfschraube 5/16" x1"	countersunk screw, hinge to body	BN4, BN6, BN7, BT7	A/R
S10SPTMK1	Türfangplatte an B-Säule	striker, door lock	BN4, BN6, BN7, BT7	2
S10AH/BN1	Dichtung Türfangplatte	plate, packing	BN4, BN6, BN7, BT7	2
S10aAH/BN1	Gewindeplatte Türfangplatte	plate, tapped	BN4, BN6, BN7, BT7	2
R10AH/BN4-s	Türdichtgummi „Flurflex“ schwarz	door seal, black	BN4, BN6, BN7, BT7	1
R10AH/BN4-b	Türdichtgummi „Flurflex“ blau	door seal, blue	BN4, BN6, BN7, BT7	1
R10AH/BN4-r	Türdichtgummi „Flurflex“ rot	door seal, red	BN4, BN6, BN7, BT7	1
R15AH/BN4	Gummiset Türecke vorne	seal, set, door to scuttle	BN4, BN6, BN7, BT7	1
S20MGA-38	Türgriff innen	door handle, interior	BN4, BN6, BN7, BT7	2
S22MGA-38	Unterlagscheibe Türöffner/Fensterkurbel	escutcheon assembly	BN4, BN6, BN7, BT7	2
KA31AH/BN4-R	Tür Aluminium rechts	door shell, aluminum RH	BN4, BN6, BN7, BT7	1
KA31AH/BN4-L	Tür Aluminium links	door shell, aluminum LH	BN4, BN6, BN7, BT7	1
KA32AH/BN4-R	Türhaut rechts	door skin, steel RH	BN4, BN6, BN7, BT7	1
KA32AH/BN4-L	Türhaut links	door skin, steel LH	BN4, BN6, BN7, BT7	1
KA32AH/BN4-RA	Türhaut rechts Aluminium	door skin, aluminum RH	BN4, BN6, BN7, BT7	1
KA32AH/BN4-LA	Türhaut links Aluminium	door skin, aluminum LH	BN4, BN6, BN7, BT7	1
S41MGA-37	Befestigungsplatte Steckfenster	plate assembly, sidecurtain securing	BN4 < 68959	2
S41AH/BN4	Befestigungsplatte Steckfenster	plate assembly, sidecurtain securing	BN4 > 68960, BN6, BN7, BT7	2
S43AH/BN4	Flügelmutter	nut, wing, sidecurtain	BN4 > 68960, BN6, BN7, BT7	2
S43MGA-37	Befestigungsmutter Seitenscheibe	nut, „L“ handle, sidecurtain	BN4 < 68959	2
S44AH/BN1	Chrom-Rand Türfangplatte	escutcheon, door trim protection	BN4, BN6, BN7, BT7	2
S45AH/BN4	Chrom-Hülse Steckfenster	socket and nut kit, sidecurtain	BN4, BN6, BN7, BT7	2
R64AH/BN1	Schraube 2BAx3/4" Senkkopf	screw, door handle to door panel	BN4, BN6, BN7, BT7	A/R
R129AH	Klammer Türdichtgummi	clip, dor seal	BN4, BN6, BN7, BT7	A/R
S226AH	Senkkopfschraube verchromt	screw, striker	BN4, BN6, BN7, BT7	8
S230AH	Unterlage Türgriff	gasket, door handle	BN4, BN6, BN7, BT7	2
KA515AH/BN4-R	Türschließmechanismus rechts	door latch assembly RH	BN4, BN6, BN7, BT7	1
KA515AH/BN4-L	Türschließmechanismus links	door latch assembly LH	BN4, BN6, BN7, BT7	1
KA530AH/L	Türfangband links	check strap assembly LH	BN4, BN6, BN7, BT7	1
KA530AH/R	Türfangband rechts	check strap assembly RH	BN4, BN6, BN7, BT7	1
i537AH/BJ8	Anschlaggummi Türgriff	buffer, door handle	BN4, BN6, BN7, BT7	2

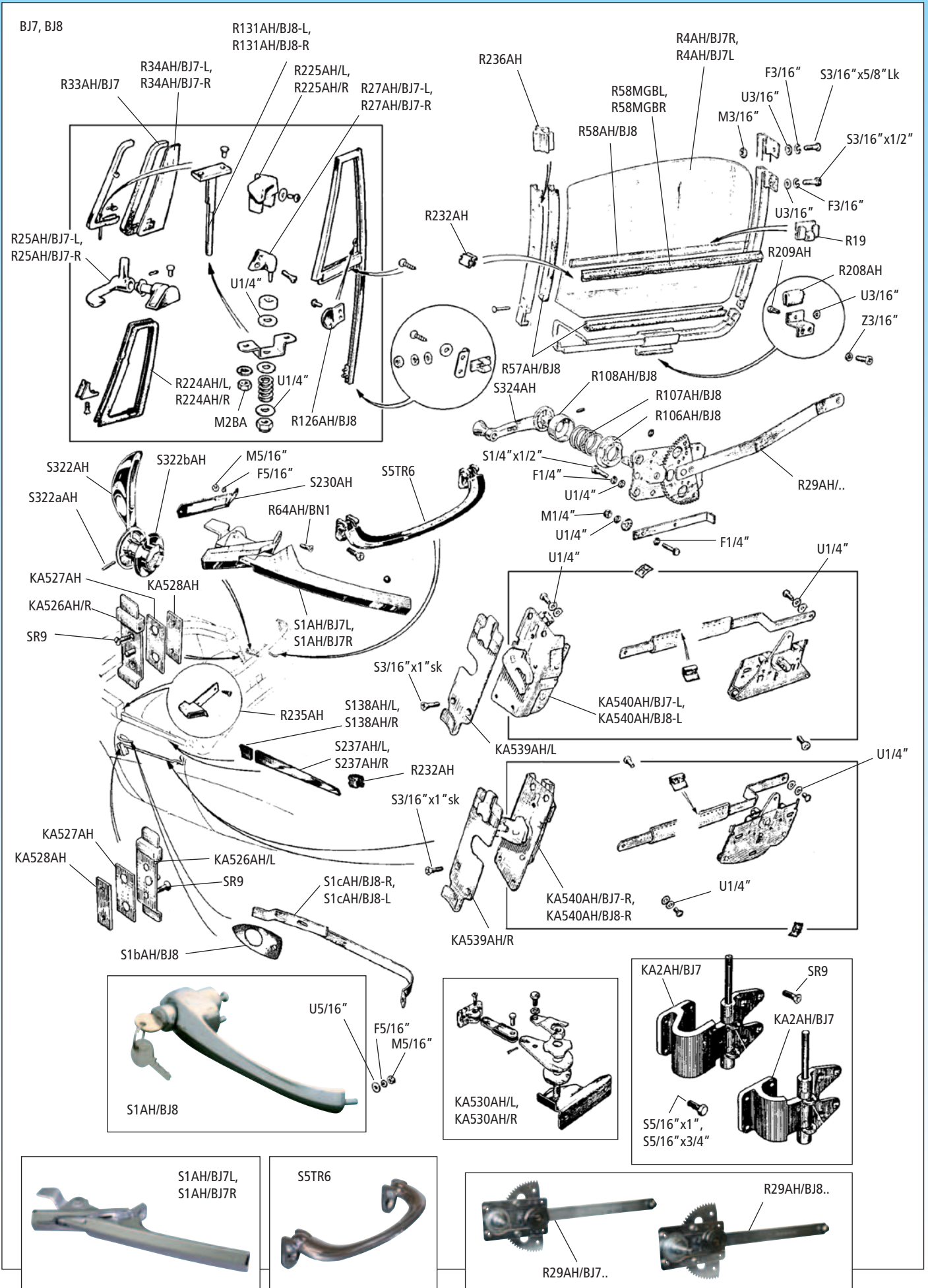

No.	Bezeichnung	Description	Type	Anzahl/Req.
S1AH/BJ7R	Türgriff aussen, Paar rechts	door handle, pair RH	BJ7-BJ8 < 26704	1
S1AH/BJ7L	Türgriff aussen, Paar links	door handle, pair LH	BJ7-BJ8 < 26704	1
S1AH/BJ8	Türgriff aussen komplett	door handle assembly, complete	BJ8 > 26705	2
S1bAH/BJ8	Türgriffunterlage	gasket, handle	BJ8 > 26705	2
S1cAH/BJ8-R	Schlossgestänge rechts	contact, door lock RH	BJ8 > 26705	1
S1cAH/BJ8-L	Schlossgestänge links	contact, door lock LH	BJ8 > 26705	1
R4AH/BJ7R	Türscheibe rechts	door glass RH	BJ7-BJ8	1
R4AH/BJ7L	Türscheibe links	door glass LH	BJ7-BJ8	1
S5TR6	Chromklappengriff Türzuzieher	door pull	BJ7-BJ8	2
SR9	Senkkopfschraube 5/16x1"	screw, striker	BJ7-BJ8	A/R
R19	Halteclip Filzleiste	clip, inner weather strip to door	BJ7-BJ8	8
R25AH/BJ7-R	Griff Ausstellfenster rechts	handle, locking RH	BJ7-BJ8	1
R25AH/BJ7-L	Griff Ausstellfenster links	handle, locking LH	BJ7-BJ8	1
R27AH/BJ7-R	Drehgelenk Ausstellfenster rechts	bracket, top pivot, outer RH	BJ7-BJ8	1
R27AH/BJ7-L	Drehgelenk Ausstellfenster links	bracket, top pivot, outer LH	BJ7-BJ8	1
R29AH/BJ7-L	Fensterheber links	window winder assembly LH	BJ7-BJ8 < 25314	1
R29AH/BJ7-R	Fensterheber rechts	window winder assembly RH	BJ7-BJ8 < 25314	1
R29AH/BJ8-L	Fensterheber links	window winder assembly LH	BJ8 > 25315	1
R29AH/BJ8-R	Fensterheber rechts	window winder assembly RH	BJ8 > 25315	1
KA31AH/BJ7-L	Tür links	door shell LH	BJ7-BJ8 < 25314	1
KA31AH/BJ7-R	Tür rechts	door shell RH	BJ7-BJ8 < 25314	1
KA31AH/BJ8f-L	Tür links	door shell LH	BJ8 > 25315 < 26704	1
KA31AH/BJ8f-R	Tür rechts	door shell RH	BJ8 > 25315 < 26704	1
KA31AH/BJ8s-L	Tür links	door shell LH	BJ8 > 26705	1
KA31AH/BJ8s-R	Tür rechts	door shell RH	BJ8 > 26705	1
KA32AH/BJ8-LA	Türhaut links Aluminium	door skin, aluminum LH	BJ8	1
KA32AH/BJ8-RA	Türhaut rechts Aluminium	door skin, aluminum RH	BJ8	1
KA32AH/BJ8-L	Türhaut links	door skin, steel LH	BJ8	1
KA32AH/BJ8-R	Türhaut rechts	door skin, steel RH	BJ8	1
KA32AH/BJ7-L	Türhaut links	door skin, steel LH	BJ7	1
KA32AH/BJ7-R	Türhaut rechts	door skin, steel RH	BJ7	1
R33AH/BJ7	Gummi-Dichtung Ausstellfenster	glazing rubber	BJ7-BJ8	2
R34AH/BJ7-L	Glas Ausstellfenster links	glass, vent window LH	BJ7-BJ8	1
R34AH/BJ7-R	Glas Ausstellfenster rechts	glass, vent window RH	BJ7-BJ8	1
R57AH/BJ8	Glashalteleiste	glazing strip, glass	BJ7-BJ8	2
R58MGBL	Regenabstreifleiste links außen	weather strip, outer LH	BJ7-BJ8	1
R58MGBR	Regenabstreifleiste rechts außen	weather strip, outer RH	BJ7-BJ8	1
R58AH/BJ8	Regenabstreifleiste innen	weather strip, inner	BJ7-BJ8	2
R64AH/BN1	Schraube 2BAx3/4" Senkkopf	screw, door handle to dor panel	BJ7-BJ8 < 26704	2
R106AH/BJ8	Abdeckung an Fensterheber	escutcheon	BJ7-BJ8	2
R107AH/BJ8	Feder an Fensterheber	spring	BJ7-BJ8	2
R108AH/BJ8	Abdeckung / Fensterheber vorne	crown	BJ7-BJ8	2
R126AH/BJ8	Platte Handverriegelung	plate, handle locking	BJ7-BJ8	2
R131AH/BJ8-L	Drehzapfen LH	pivot, lower LH	BJ7-BJ8	1
R131AH/BJ8-R	Drehzapfen RH	pivot, lower RH	BJ7-BJ8	1
S138AH/L	Endstück Verkleidung seitl. links	finisher, rear quarter panel LH	BJ7-BJ8	1
S138AH/R	Endstück Verkleidung seitl. rechts	finisher, rear quarter panel RH	BJ7-BJ8	1
R208AH	Anschlaggummi	buffer, rubber	BJ7-BJ8	2
R209AH	Stift für Anschlaggummi	rivet	BJ7-BJ8	2
R224AH/L	Gummi-Dichtung Ausstellfenster links	sealing, rubber LH	BJ7-BJ8	1
R224AH/R	Gummi-Dichtung Ausstellfenster rechts	sealing, rubber RH	BJ7-BJ8	1
R225AH/R	Gummi-Ecke Ausstellfenster rechts	tip set, top corner RH	BJ7-BJ8	1
R225AH/L	Gummi-Ecke Ausstellfenster links	tip set, top corner LH	BJ7-BJ8	1
S230AH	Unterlage Türgriff	gasket, sealing	BJ7-BJ8 < 26704	2
R232AH	Klammer Wetterleiste	clip, moulding and weather strip	BJ7-BJ8	A/R
S324AH	Fensterkurbel	window winder handle	BJ7-BJ8	2
R235AH	Dichtungen seitlich oben Paar	seal, shut pillar, top (pair)	BJ7 > 57500, BJ8	1
R236AH	Gleitlager Fenster Nylon	guide, door glass, nylon	BJ7-BJ8	6

- Fortsetzung s. nächste Seite

- to be continued on next page

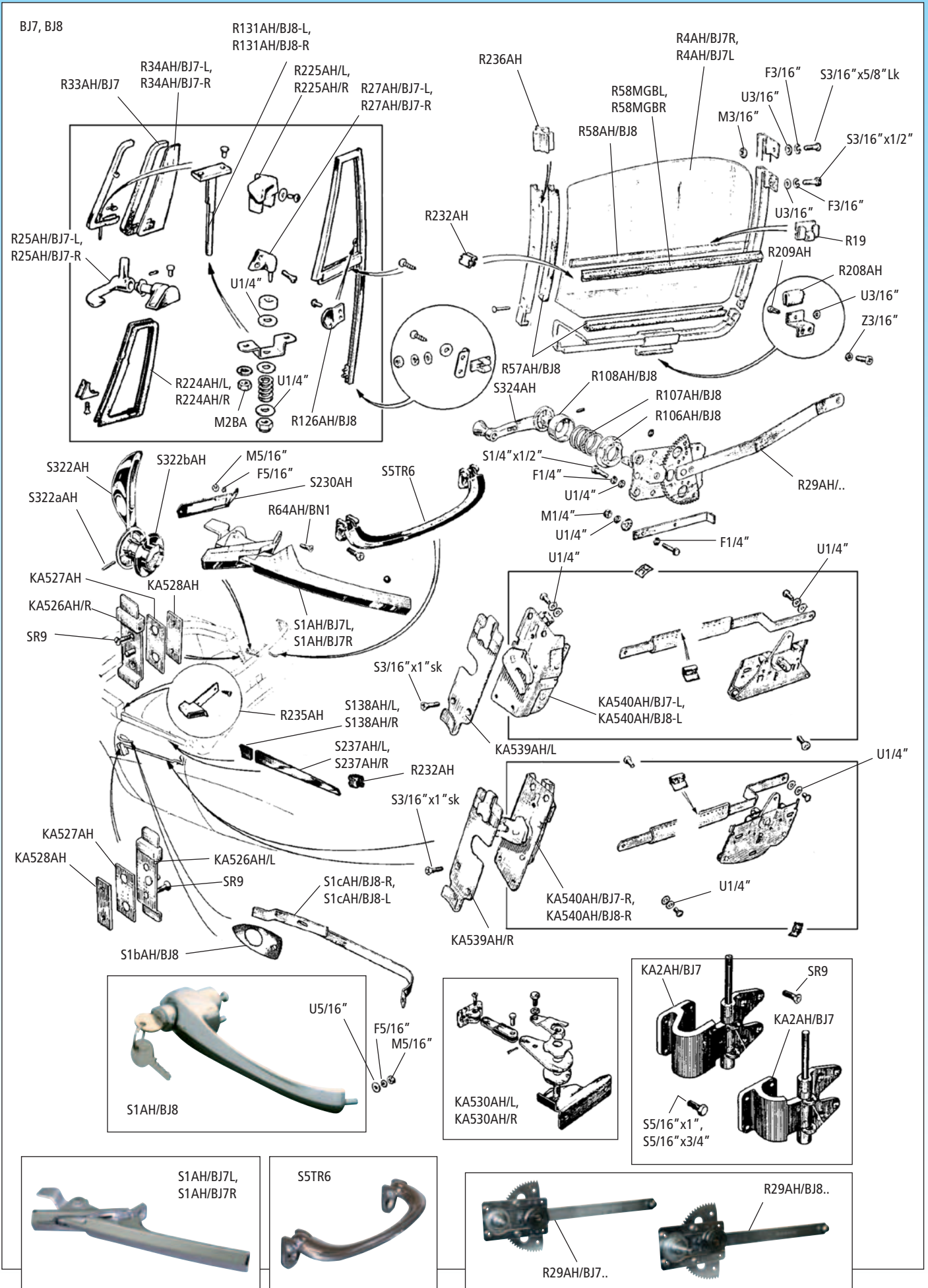

No.	Bezeichnung	Description	Type	Anzahl/Req.
S237AH/L	Chrom-Blende Türe links oben	moulding, door waist LH	BJ7-BJ8	1
S237AH/R	Chrom-Blende Türe rechts oben	moulding, door waist RH	BJ7-BJ8	1
S322AH	Griff Türöffner innen	door handle, interior	BJ7-BJ8	2
S322aAH	Stift Türöffner innen	peg, handle	BJ7-BJ8	2
S322bAH	Abdeckung Türöffner innen	escutcheon, door handle	BJ7-BJ8	2
KA526AH/L	Türfangplatte links an B-Säule	striker, door lock LH	BJ7-BJ8	1
KA526AH/R	Türfangplatte rechts an B-Säule	striker, door lock RH	BJ7-BJ8	1
KA527AH	Unterlage Schlossplatte	plate, packing, striker	BJ7-BJ8	2
KA528AH	Gewindeplatte Schlossplatte	plate, tapped, striker	BJ7-BJ8	2
KA530AH/L	Türfangband links	check strap assembly LH	BJ7-BJ8	1
KA530AH/R	Türfangband rechts	check strap assembly RH	BJ7-BJ8	1
KA539AH/L	Platte Türschloss links	lock plate LH	BJ7-BJ8	1
KA539AH/R	Platte Türschloss rechts	lock plate RH	BJ7-BJ8	1
KA540AH/BJ7-R	Türschloss rechts	lock assembly RH	BJ7-BJ8 < 25314	1
KA540AH/BJ7-L	Türschloss links	lock assembly LH	BJ7-BJ8 < 25314	1
KA540AH/BJ8-R	Türschloss rechts	lock assembly RH	BJ8 > 25315	1
KA540AH/BJ8-L	Türschloss links	lock assembly LH	BJ8 > 25315	1

Wetterschutz / Weather Equipment BN1, BN2

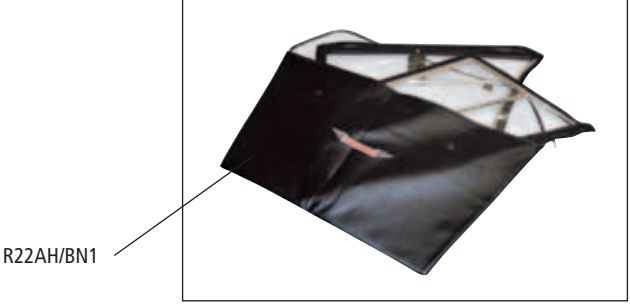
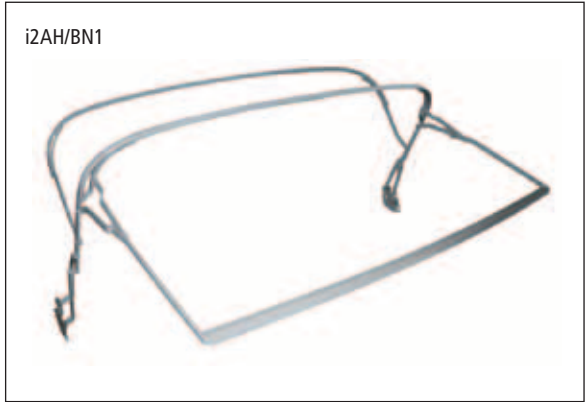
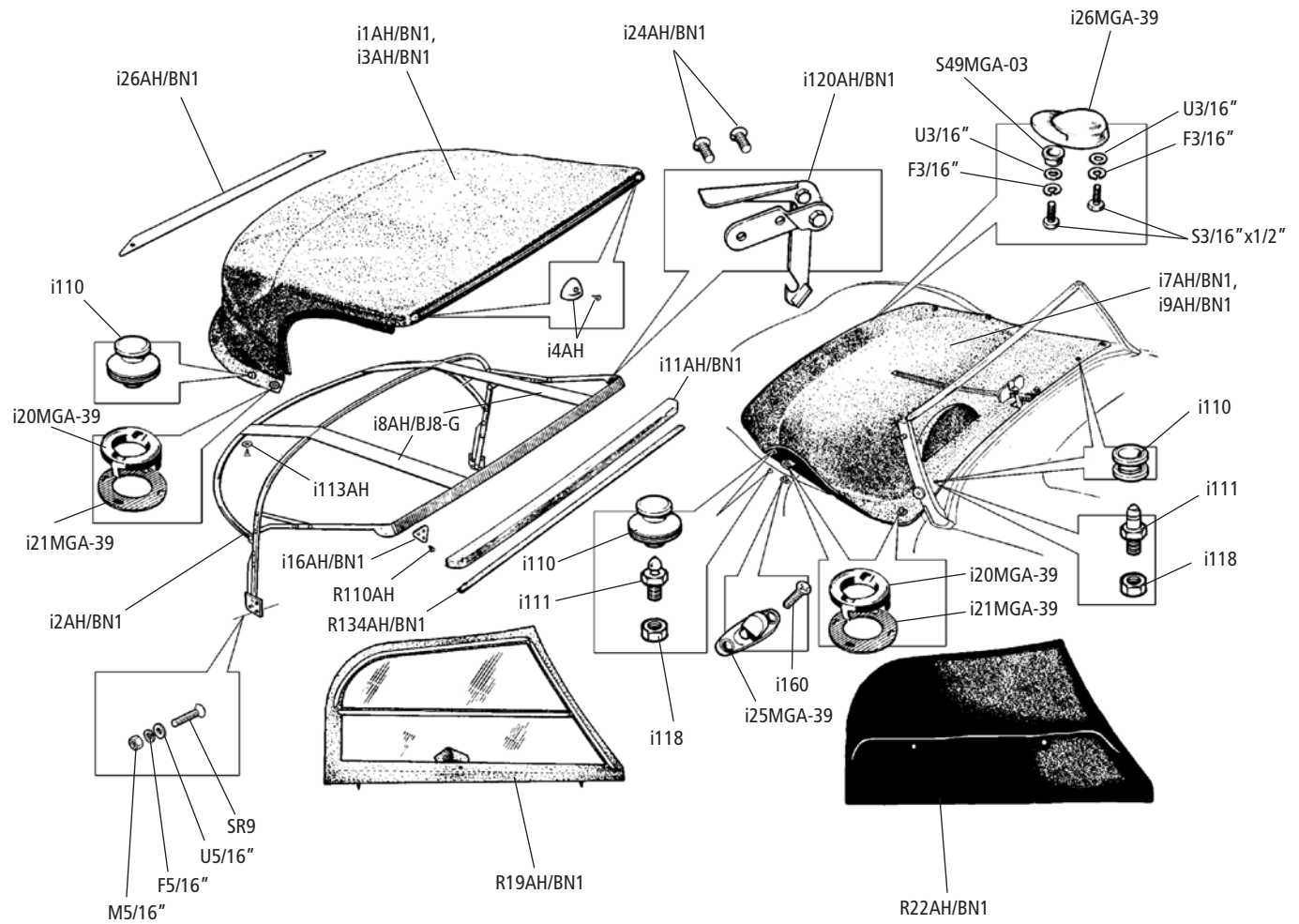

Wetterschutz / Weather Equipment BN1, BN2

No.	Bezeichnung	Description	Type	Anzahl/Qty.
i1AH/BN1	Verdeck PVC schwarz	top, black, PVC	BN1-BN2	1
i1AH/BN1-C	Verdeck PVC farbig	top, coloured, PVC	BN1-BN2	1
i2AH/BN1	Verdeckgestänge	top frame assembly	BN1-BN2	1
i3AH/BN1	Verdeck Mohair schwarz	top, black, Mohair	BN1-BN2	1
i4AH	Endkappe Verdeck vorne	finisher, header rail	BN1-BN2	2
i7AH/BN1	Persenning PVC schwarz	tonneau cover, black, PVC	BN1-BN2	1
i7AH/BN1-RHD	Persenning PVC schwarz Rechtslenker	tonneau cover, black, PVC (RHD)	BN1-BN2	1
i8AH/BJ8-G	Verdeck-Riemen 3 m	webbing set, top frame (3 meter)	BN1-BN2	1
i9AH/BN1	Persenning Mohair schwarz	tonneau cover, black, Mohair	BN1-BN2	1
i9AH/BN1-RHD	Persenning Mohair schwarz Rechtslenker	tonneau cover, black, Mohair (RHD)	BN1-BN2	1
SR9	Senkkopfschraube	screw	BN1-BN2	6
i11AH/BN1	Verdeck-Holz-Leiste vorne	header rail, wood	BN1-BN2	1
i16AH/BN1	Halter Verdeck-Gestell	retainer, header rail	BN1-BN2	3
R19AH/BN1-S	Steckfenster (Paar)	sidecurtain set, pair	BN1-BN2	1
i20MGA-39	Oberer Ring für Drehverschluss	eyelet for turn button, upper	BN1-BN2	A/R
i21MGA-39	Unterer Ring für Drehverschluss	eyelet for turn button, lower	BN1-BN2	A/R
R22AH/BN1	Steckfenstertasche	sidecurtain stowage bag	BN1-BN2	1
i24AH/BN1	Verdeck-Befestigungsstift	screw, clamp to header rail	BN1-BN2	4
i25MGA-39	Drehverschuß	turnbuckle	BN1-BN2	4/2
i26AH/BN1	Verdeck-Halteleiste hinten	top anchor bar, rear	BN1-BN2	1
i26MGA-39	Chromhalterung Verdeckleiste hinten	retainer „teardrop“ on shroud	BN1-BN2	2
S49MGA-03	Unterlegdeckel Chromhalterung Verdeck	washer cup, hood retaining plate	BN1-BN2	2
i100	Verdeckdruckknopf außen chrom	button hood, outer fixing, chrome	BN1-BN2	A/R
i101	Verdeckdruckknopf außen schwarz	button hood, outer fixing, black	BN1-BN2	A/R
i102	Verdeckdruckknopf Oberteil unten	button hood, upper	BN1-BN2	A/R
i103	Befestigungsclip-Gegenstück auf Karosserie	stud, hood, rear	BN1-BN2	A/R
R110AH	Gummiknopf Verdeck-Gestell	buffer, header rail	BN1-BN2	3
i110	Tenax Oberteil	sail eyelet & washer	BN1-BN2	A/R
i111	Tenax Unterteil mit Schraubgewinde	stud, Lift the dot	BN1-BN2	A/R
i112	Tenax Unterteil Blechgewinde	stud, Lift the dot plate fixing	BN1-BN2	A/R
i113	Lift the dot Verdeckknopfunterteil Schraubgewinde	peg, tonneau fixing	BN1-BN2	A/R
i113AH	Conus-Unterlagscheibe	washer	BN1-BN2	A/R
i114	Lift the dot Verdeckknopfunterteil	peg, fastener	BN1-BN2	A/R
i115	Lift the dot Verdeckknopfunterteil Blechgewinde	peg, fastener plate fixing	BN1-BN2	A/R
i117	Mutter 3/16"	nut 3/16"	BN1-BN2	A/R
i118	Mutter M5 für i111	nut M5 to part i111	BN1-BN2	A/R
i120AH/BN1	Verdeck-Verschlüsse Paar	clamp set, pair	BN1-BN2	1
R134AH/BN1	Gummi-Dichtung Verdeck	header, rail seal	BN1-BN2	1
i150	Druckknopf	fastener	BN1-BN2	A/R
i160	Schraube und Rosette	screw and Chrom cap washer	BN1-BN2	A/R
i161	Blechmutter	nut	BN1-BN2	A/R
WZ60	Druckknopf Montagewerkzeug	button hood fixing tool	BN1-BN2	A/R
WZ61	Schlüssel Tenax-Unterteil	Tenax key	BN1-BN2	A/R

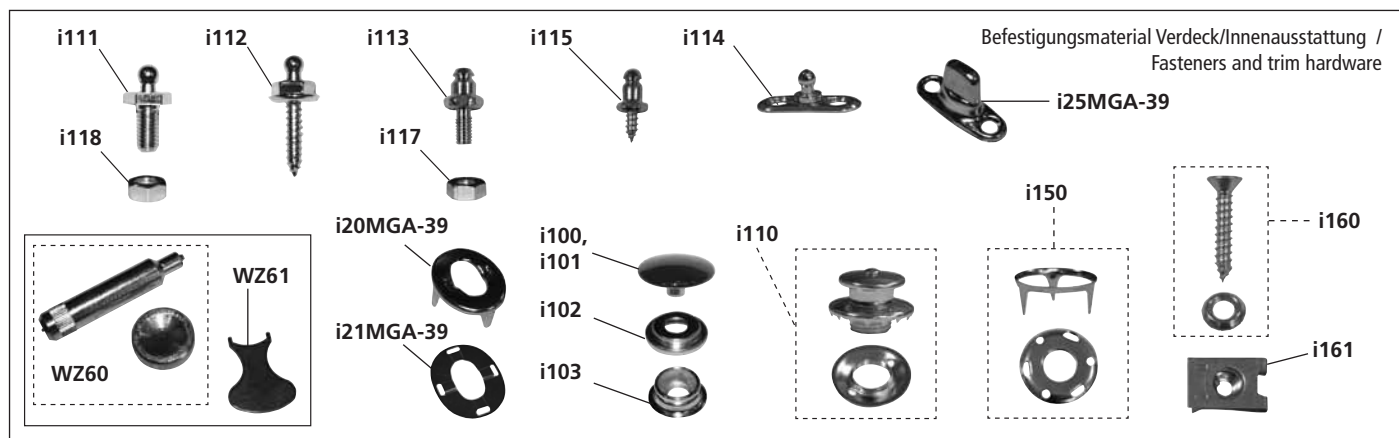

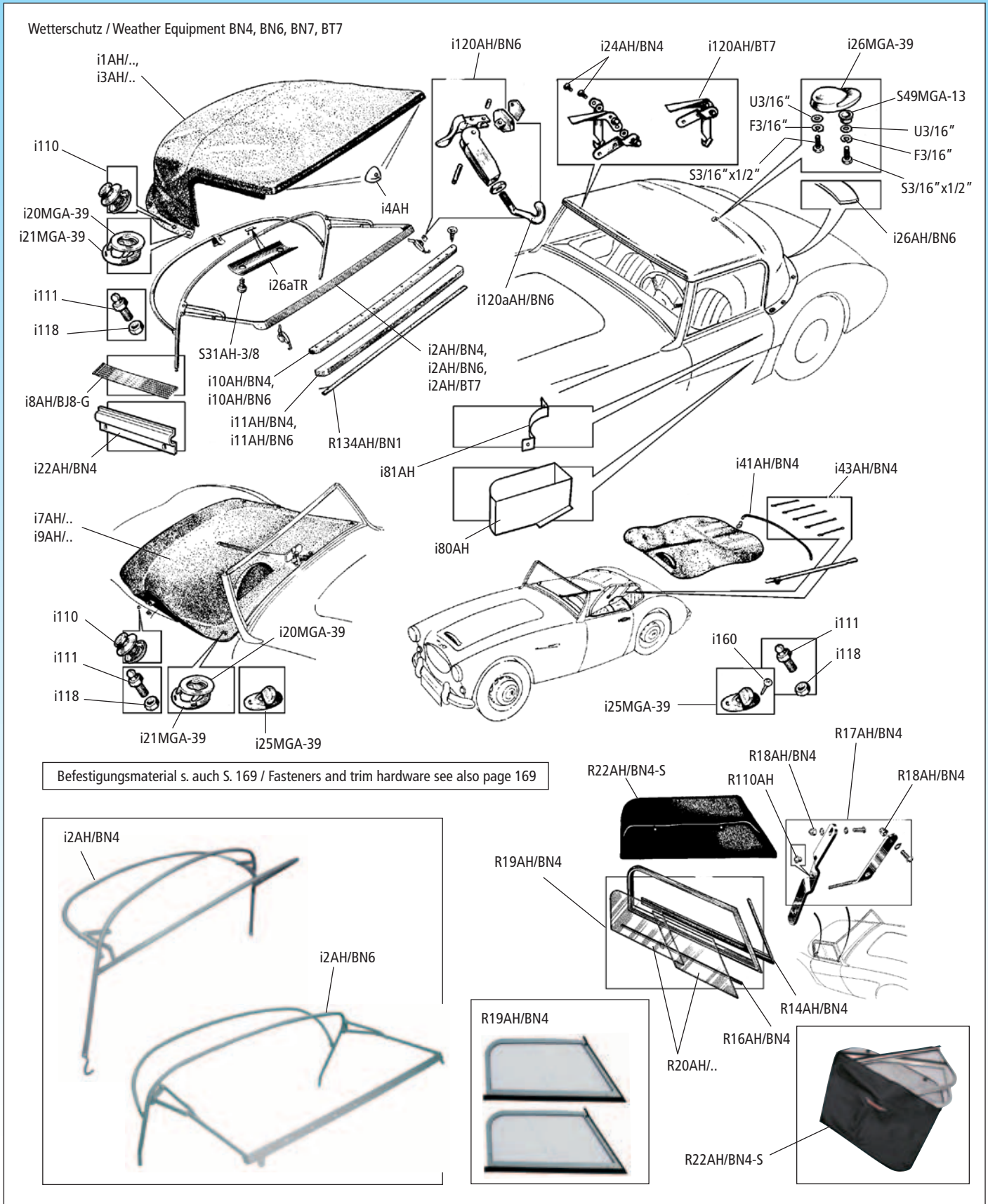

Wetterschutz / Weather Equipment BN4, BN6, BN7, BT7

No.	Bezeichnung	Description	Type	Anzahl/ Req.
i1AH/BN4	Verdeck PVC schwarz	top, black, PVC	BN4<68959	1
i1AH/BN4-C	Verdeck PVC farbig	top, coloured, PVC	BN4<68959	1
i1AH/BN6	Verdeck PVC schwarz	top, black, PVC	BN6 + BN7	1

Wetterschutz / Weather Equipment BN4, BN6, BN7, BT7

No.	Bezeichnung	Description	Type	Anzahl/Qty.
i1AH/BN6-C	Verdeck PVC farbig	top, black, PVC	BN6 + BN7	1
i1AH/BT7	Verdeck PVC schwarz	top, coloured, PVC	BN4>68960; BT7	1
i1AH/BT7-C	Verdeck PVC farbig	top, black, PVC	BN4>68960; BT7	1
i2AH/BN4	Verdeckgestänge	top frame assembly	BN4<68959	1
i2AH/BN6	Verdeckgestänge	top frame assembly	BN6 + BN7	1
i2AH/BT7	Verdeckgestänge	top frame assembly	BN4>68960; BT7	1
i3AH/BN4	Verdeck Mohair schwarz	top, black, Mohair	BN4<68959	1
i3AH/BN6	Verdeck Mohair schwarz	top, black, Mohair	BN6 + BN7	1
i3AH/BT7	Verdeck Mohair schwarz	top, black, Mohair	BN4>68960; BT7	1
i4AH	Endkappe Verdeck vorne	finisher, header rail	BN4, BN6, BN7, BT7	2
i8AH/BJ8-G	Verdeck-Riemen grau	webbing set, top frame, grey	BN4, BN6, BN7, BT7	1
i7AH/BN4	Persenning PVC schwarz	tonneau cover, black, PVC	BN4; BT7	1
i7AH/BN4-RHD	Persenning PVC schwarz Rechtslenker	tonneau cover, black, PVC (RHD)	BN4; BT7	1
i7AH/BN6	Persenning PVC schwarz	tonneau cover, black, PVC	BN6 + BN7	1
i7AH/BN6-RHD	Persenning PVC schwarz Rechtslenker	tonneau cover, black, PVC (RHD)	BN6 + BN7	1
i9AH/BN4	Persenning Mohair schwarz	tonneau cover, black, Mohair	BN4; BT7	1
i9AH/BN4-RHD	Persenning Mohair schwarz Rechtslenker	tonneau cover, black, Mohair (RHD)	BN4; BT7	1
i9AH/BN6	Persenning Mohair schwarz	tonneau cover, black, Mohair	BN6 + BN7	1
i9AH/BN6-RHD	Persenning Mohair schwarz Rechtslenker	tonneau cover, black, Mohair (RHD)	BN6 + BN7	1
i10AH/BN4	Verdeck-Leiste Aluminium vorne	retaining rail, aluminium	BN4 + BT7	1
i10AH/BN6	Verdeck-Leiste Aluminium vorne	retaining rail, aluminium	BN6 + BN7	1
i11AH/BN4	Verdeck-Holz-Leiste vorne	header rail, wood	BN4 + BT7	1
i11AH/BN6	Verdeck-Holz-Leiste vorne	header rail, wood	BN6 + BN7	1
R14AH/BN4	Dichtgummisatz Steckscheiben	weatherstrip set	BN4, BN6, BN7, BT7	1
R16AH/BN4	Filzeinsatz für Schiene Steckfenster	channel felt	BN4, BN6, BN7, BT7	1
R17AH/BN4	Halter Steckfenster Satz	bracket set, sidecurtain fitting	BN4, BN6, BN7, BT7	1
R18AH/BN4	Hutmutter Steckfensterhalter	dome nut	BN4, BN6, BN7, BT7	2
R19AH/BN4	Steckfenster Paar	sidecurtain set, pair	BN4, BN6, BN7, BT7	1
R20AH/BN4	Plexiglas-Scheiben Satz	window set, acryl	BN4<68959	1
R20AH/BN6	Plexiglas-Scheiben Satz	window set, acryl	BN4>68960, BN6, BN7, BT7	1
i20MGA-39	Oberer Ring für Drehverschluss	eyelet for turn button, upper	BN4, BN6, BN7, BT7	A/R
i21MGA-39	Unterer Ring für Drehverschluss	eyelet for turn button, lower	BN4, BN6, BN7, BT7	A/R
R22AH/BN4-S	Steckfenstertasche	sidecurtain stowage bag	BN4<68959	1
i22AH/BN4	Führungsleiste Verdeck, Paar	slide rail, pair	BN4, BN6, BN7, BT7	1
i24AH/BN4	Verdeck-Befestigungs-Stift	screw, clamp to header rail	BN4, BN6, BN7, BT7	4
i25MGA-39	Drehverschluß	turnbuckle	BN6 + BN7	2
i26AH/BN6	Verdeck-Halteleiste hinten	top anchor bar, rear	BN6, BN7	1
i26aTR	Halteblech Verdeckspannband	clip top to frame	BN4, BN6, BN7, BT7	4
i26MGA-39	Chromhalter Verdeckleiste hinten	retainer, top	BN4, BN6, BN7, BT7	2
S31AH-3/8	Schraube selbstschneidend NO6x3/8"	screw	BN4>68960; BT7	8
i41AH/BN4	Stange Spritzdecke	rail, tonneau support	BN4; BT7	1
i43AH/BN4	Spritzdecken-Bef.-Satz	stiffener set	BN4, BN6, BN7, BT7	1
S49MGA-13	Unterlegdeckel Chromhalterung Verdeck	washer cup, hood retaining plate	BN4, BN6, BN7, BT7	2
i80AH/L	Verdeckverstaueung LH	stowage box LH	BN4, BN6, BN7, BT7	1
i80AH/R	Verdeckverstaueung RH	stowage box RH	BN4, BN6, BN7, BT7	1
i81AH	Halter für Verdeckverstaueung	strap, top frame	BN4, BN6, BN7, BT7	1
R110AH	Gummi-Anschlagstopfen Steckfenster	washer, special (rubber)	BN4, BN6, BN7, BT7	2
i110	Tenax Oberteil	sail eyelet & washer	BN4, BN6, BN7, BT7	A/R
i111	Tenax Unterteil mit Schraubgewinde	stud, Lift the dot	BN4, BN6, BN7, BT7	A/R
i112	Tenax Unterteil Blechgewinde	stud, Lift the dot plate fixing	BN4, BN6, BN7, BT7	A/R
i113	Lift the dot Verdeckknopfunterteil Schraubgewinde	peg, tonneau fixing	BN4, BN6, BN7, BT7	A/R
i114	Lift the dot Verdeckknopfunterteil	peg, fastener	BN4, BN6, BN7, BT7	A/R
i115	Lift the dot Verdeckknopfunterteil Blechgewinde	peg, fastener plate fixing	BN4, BN6, BN7, BT7	A/R
i116	Lift the dot Verdeckknopfberteil	eyelet and washer, turnbuckle	BN4, BN6, BN7, BT7	A/R
i117	Mutter 3/16"	nut 3/16"	BN4, BN6, BN7, BT7	A/R
i118	Mutter M5 für i111	nut M5 to part i111	BN6 + BN7	A/R
i120AH/BN6	Verdeck-Verschlüsse Paar	clamp set, pair	BN4>28103/RHD;	1
i120AH/BT7	Verdeck-Verschlüsse Paar	clamp set, pair	BN4>28914/LHD; BT7	1
i120aAH/BN6	Haken Dachverschluss (Paar)	hook, pair	BN4, BN6, BN7, BT7	1
R134AH/BN1	Gummi-Dichtung Verdeck	header, rail seal	BN4, BN6, BN7, BT7	1
i160	Schraube und Rosette	screw and plate	BN4, BN6, BN7, BT7	A/R

Wetterschutz / Weather Equipment BJ7, BJ8

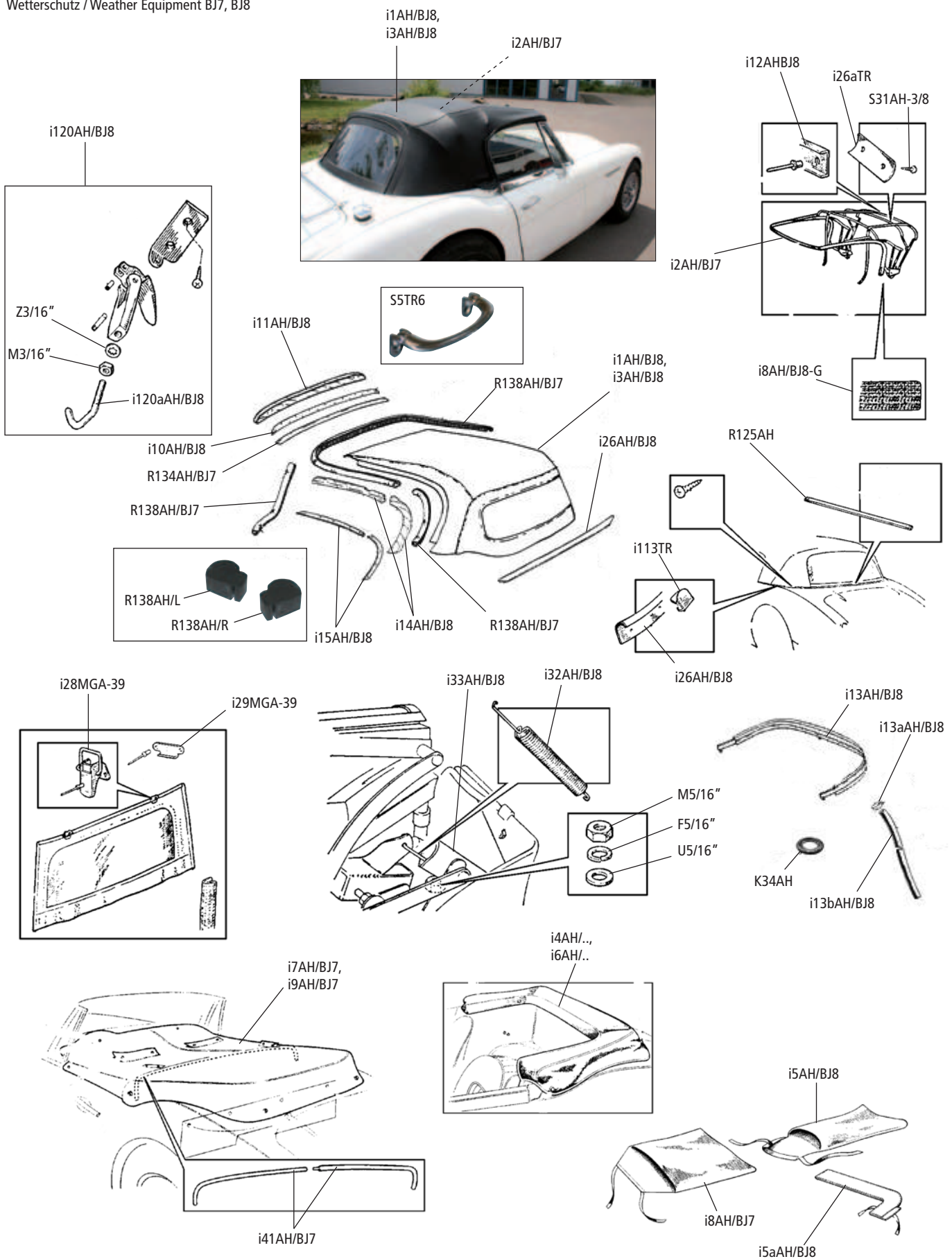

Befestigungsmaterial s. auch S. 169 / Fasteners and trim hardware see also page 169

Wetterschutz / Weather Equipment BJ7, BJ8

No.	Bezeichnung	Description	Type	Anzahl/Qty.
i1AH/BJ8	Verdeck PVC schwarz Reisverschluss Heckfester	top, black, PVC	BJ7-BJ8	1
i1AH/BJ8-C	Verdeck PVC farbig Reisverschluss Heckfester	top, coloured, PVC	BJ7-BJ8	1
i2AH/BJ7	Verdeckgestänge	top frame assembly	BJ7-BJ8	1
i3AH/BJ8	Verdeck Mohair schwarz	top, black, Mohair	BJ7, BJ8	1
i4AH/BJ7	Verdeckabdeckung PVC schwarz	top stowage cover, black, PVC	BJ7	1
i4AH/BJ8	Verdeckabdeckung PVC schwarz	top stowage cover, black, PVC	BJ8	1
S5TR6	Griff Verdeck	handle, header rail	BJ7, BJ8	1
i5aAH/BJ8	Tasche für Schienen Spritzdecke	stowage bag, tonneau support rails	BJ7-BJ8	1
i5AH/BJ8	Tasche für Verdeckabdeckung	stowage bag, top stowage cover	BJ7-BJ8	1
i6AH/BJ7	Verdeckabdeckung Mohair schwarz	top stowage cover, black, Mohair	BJ7	1
i6AH/BJ8	Verdeckabdeckung Mohair schwarz	top stowage cover, black, Mohair	BJ8	1
i7AH/BJ7	Persenning PVC schwarz	tonneau cover, black, PVC	BJ7-BJ8	1
i7AH/BJ7-RHD	Persenning PVC schwarz Rechtslenker	tonneau cover, black, PVC, RHD	BJ7-BJ8	1
i8AH/BJ8-G	Verdeck-Riemen 3 m grau	webbing set, top frame, grey (3 meter)	BJ7-BJ8	1
i8AH/BJ7	Tasche für Persenning	stowage bag, tonneau	BJ7-BJ8	1
i9AH/BJ7	Persenning Mohair schwarz	tonneau cover, black, Mohair	BJ7-BJ8	1
i9AH/BJ7-RHD	Persenning Mohair schwarz Rechtslenker	tonneau cover, black, Mohair, RHD	BJ7-BJ8	1
i10AH/BJ8	Verdeck-Leiste Aluminium vorne	retaining rail, aluminium	BJ7-BJ8	1
i11AH/BJ8	Verdeck-Holz-Leiste vorne	header rail, wood	BJ7-BJ8	1
i12AH/BJ8	Leiste Verdeckgestänge hinten	trim rail, upper	BJ7, BJ8	1
i13aAH/BJ8	Clip an Wasserkanal	clip, canopy to rear trim rail	BJ7-BJ8	1
i13AH/BJ8	Leiste Wasserkanal am Verdeck	trim rail, top water channel	BJ7-BJ8	1
i13bAH/BJ8	Wasserabgangsrohr Verdeck	hose, water drain, hood	BJ7-BJ8	1
i14AH/BJ8	Satz Holzleisten (4) seitlich Verdeck	wood strip set (4 pieces)	BJ7-BJ8	1
i15AH/BJ8	Verdeckleisten Satz seitol. (4)	retainer set (4 pieces)	BJ7-BJ8	1
i26AH/BJ8	Verdeck-Leiste hinten	top anchor bar, rear	BJ7-BJ8	1
i26aTR	Halteblech Verdeckspannband	clip, web retaining	BJ7-BJ8	2
i28MGA-39	Verdeckverschluß vorne am Verdeckbalken	fastener, zinc plated	BJ7-<59371	2
i29MGA-39	Aufnahme Verdeckverschluß am Frontscheibenrahmen	catch, window toggle fastener	BJ7-BJ8	2
S31AH-3/8	Schraube selbstschneidend NO6x3/8"	screw	BJ7-BJ8	4
i32AH/BJ8	Feder Verdeckgestänge	spring	BJ7-BJ8	2
i33AH/BJ8	Hülle Feder Verdeckgestell	cover, spring	BJ7-BJ8	2
K34AH	Dichtgummi Schlauch/Spritzwand	seal hose/body	BJ7-BJ8	1
i41AH/BJ7	Stange Spritzdecke	support rail set, tonneau	BJ7>68691, BJ8	1
i110	Tenax Oberenteil	sail eyelet & washer	BJ7-BJ8	A/R
i111	Tenax Unterteil mit Schraubgewinde	stud, Lift the dot	BJ7-BJ8	A/R
i112	Tenax Unterteil Blechgewinde	stud, Lift the dot plate fixing	BJ7-BJ8	A/R
i113	Lift the dot Verdeckknopfunterteil Schraubgewinde	peg, tonneau fixing	BJ7-BJ8	A/R
i113TR	Halteclip	clip	BJ7-BJ8	A/R
i114	Lift the dot Verdeckknopfunterteil	peg, fastener	BJ7-BJ8	A/R
i115	Lift the dot Verdeckknopfunterteil Blechgewinde	peg, fastener plate fixing	BJ7-BJ8	A/R
i116	Lift the dot Verdeckknopfberteil	eyelet and washer, turnbuckle	BJ7-BJ8	A/R
i117	Mutter 3/16"	nut 3/16"	BJ7-BJ8	A/R
i118	Mutter M5 für I111	nut M5 to part i111	BJ7-BJ8	A/R
i120AH/BJ8	Verdeck-Verschlüsse	clamp set	BJ7-BJ8	1
i120aAH/BJ8	Haken Dachverschluss (Paar)	hook, pair	BJ7, BJ8	1
R125AH	Dichtung Verdeck zu Wasserkanal	seal, top to water channel	BJ7, BJ8	1
R134AH/BJ7	Dichtgummi Verdeck vorne	hood seal	BJ7-BJ8	1
R138AH/BJ7	Satz Dichtummis Verdeckgestänge zu Seitenscheiben	seal set, top frame/side window	BJ7-BJ8	1
R138AH/L	Verdeck-Schutzzecke LH	cap LH	BJ7-BJ8	3
R138AH/R	Verdeck-Schutzzecke RH	cap RH	BJ7-BJ8	3
M3/16"	Mutter 3/16" UNF	nut 3/16" UNF	BJ7-BJ8	
Z3/16"	Zahnscheibe 3/16"	washer 3/16", shakeproof	BJ7-BJ8	2

Abb. zeigt rechtsgelenkte Ausführung / fig.: RHD illustrated

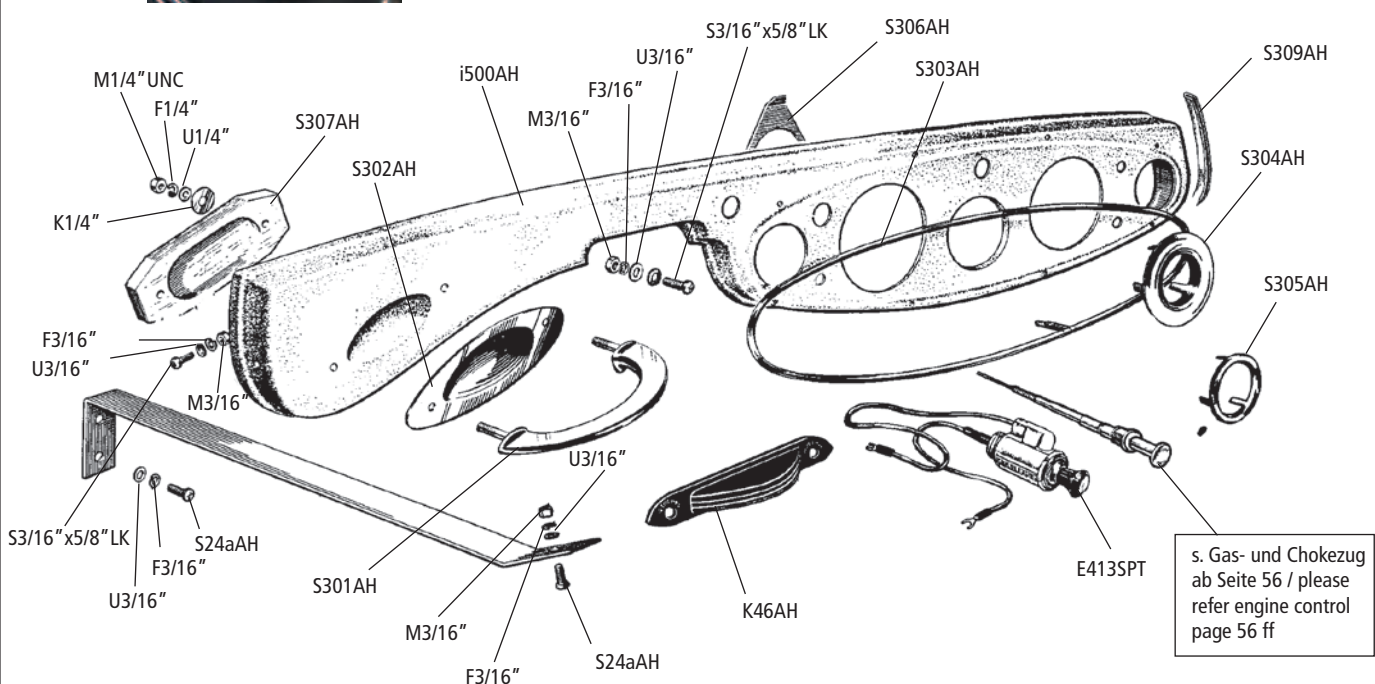
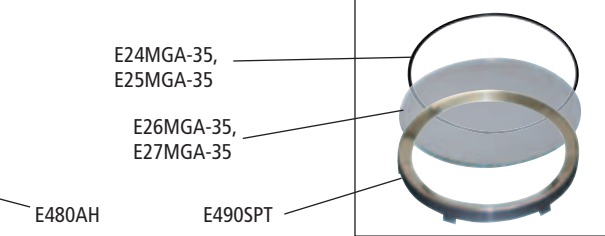
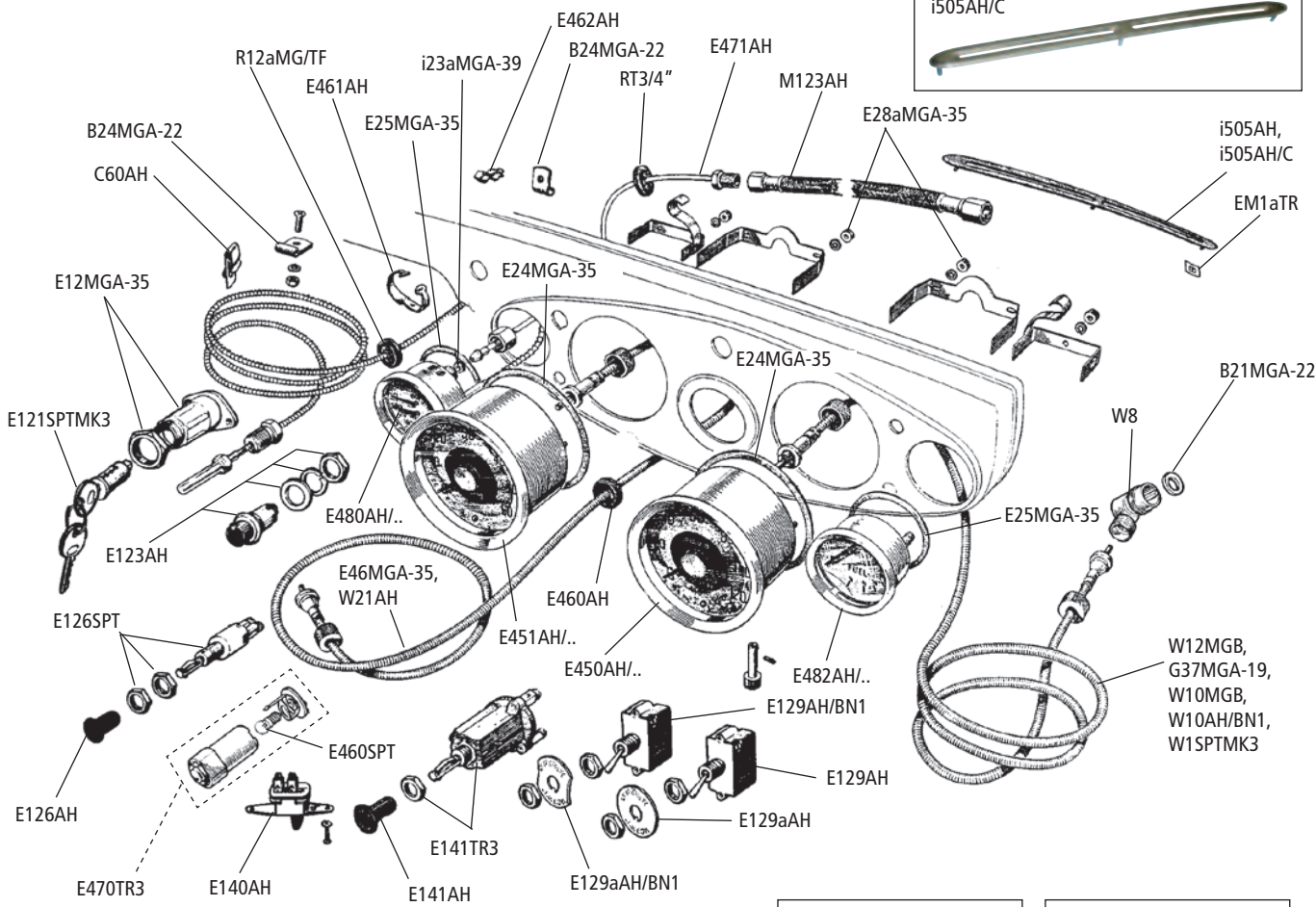

s. Gas- und Chokezug
ab Seite 56 / please
refer engine control
page 56 ff

No.	Bezeichnung	Description	Type	Anzahl/Req.
Tachowelle und Drehzahlmesserwelle / Speedometer and Tachometer				
W1SPTMK3	Tachowelle 69"	cable speedometer 69"	BN7>5588, BT7>6774	1
W8	Winkelantrieb Tachowelle Overdrive	angle drive, speedometer/O/D	BN4, BN6, BN7, BT7, BJ7	1
W8AH/BN1	Winkelantrieb - benutze W8 Winkelantrieb & Tachowelle W10MGB	angle drive, speedometer - please use no. W8 and W10MGB	BN1, BN2	1
W10AH/BN1	Tachowelle	cable, speedometer	BN1, BN2	1
W10MGB	Tachowelle Schaltgetriebe	cable, speedometer	BN7, BT7, BJ7	1
W12MGB	Tachowelle 48"	cable, speedometer 48"	BN4, BN6, BN7	1
B21MGA-22	Kupferscheibe 7/16"	washer, copper	BN1, BN2, BN4, BN6, BN7, BT7, BJ7	1
W21AH	Drehzahlmesserwelle 29" LHD	cable, tachometer 29" LHD	BN1, BN2	1
W21AH	Drehzahlmesserwelle 29" RHD	cable, tachometer 29" RHD	BN4, BN6, BN7, BT7, BJ7	1
E24MGA-35	Instrumenten-Dichtring „groß“	ring, sealing	BN1, BN2, BN4, BN6, BN7, BT7, BJ7	2
E26MGA-35	Instrumenten-Glass „groß“	glass	BN1, BN2, BN4, BN6, BN7, BT7, BJ7	2
E28aMGA-35	Rändelmutter Instrumentenbefestigung	nut, thumb	BN1, BN2, BN4, BN6, BN7, BT7, BJ7	4
G37MGA-19	Tachowelle 63"	cable, speedometer 63"	BN4, BN6, BN7<5588, BT7<6774	1
E46MGA-35	Drezahlmesserwelle 40" RHD	cable, tachometer 40" RHD	BN1, BN2	1
E46MGA-35	Drezahlmesserwelle 40" LHD	cable, tachometer 40" LHD	BN4, BN6, BN7, BT7, BJ7	1
E450AH/BN1	Tachometer Instandsetzung SN6305/OD	speedometer, exchange, SN6305/OD	BN1-BN2	1
E450AH/BN4	Tachometer Instandsetzung ohne Overdrive SN6105/06	speedometer, exchange, w/o O/D SN6105/06	BN4, BN6	1
E450AH/BN4-OD	Tachometer Instandsetzung mit Overdrive SN6105/08	speedometer, exchange, O/D SN6105/08	BN4, BN6	1
E450AH/BJ7	Tachometer Instandsetzung ohne Overdrive SN6155/19 3.45:1	speedometer, exchange, w/o O/D SN6155/19 3.45:1	BN7, BT7, BJ7	1
E450AH/BJ7-OD	Tachometer Instandsetzung mit Overdrive SN6155/21 3.909:1	speedometer, exchange, O/D SN6155/21 3.909:1	BN7, BT7, BJ7	1
E451AH/BN1	Drezahlmesser Instandsetzung RN2301/00	tachometer, exchange, RN2301/00	BN1, BN2, 100M	1
E451AH/BN4	Drezahlmesser Instandsetzung RN2301/03	tachometer, exchange, RN2301/03	BN4, BN6, BN7, BT7, BJ7	1
E460AH	Gummitülle	grommet	BN1, BN2, BN4, BN6, BN7, BT7, BJ7	1
E490SPT/100	Chromrand für Instrumente Ø 100 mm	bezel, tacho & speedometer, Ø 100 mm	BN1, BN2, BN4, BN6, BN7, BT7, BJ7	2

Armaturenbrett / Dashboard and Fittings

EM1aTR	Halteclip für Chrombuchstaben	nut, spire	BN1, BN2, BN4, BN6, BN7, BT7, BJ7	6
S24aAH	Chromschraube 3/16"x1/2"UNF No.10	screw 3/16"x1/2"UNF	BN1, BN2, BN4, BN6, BN7, BT7, BJ7	1
K46AH	Schieberblende Heizung	panel, heater control	BN4, BN6, BN7, BT7, BJ7	1
E116SPT	Warnblinkanlage zum Nachrüsten	hazard warning unit	BN1, BN2, BN4, BN6, BN7, BT7, BJ7	1
S301AH	Haltegriff Armaturenbrett	grab handle	BN1, BN2, BN4, BN6, BN7, BT7, BJ7	1
S302AH	Chromschale Haltegriff	escutcheon, handle	BN1, BN2, BN4, BN6, BN7, BT7, BJ7	1
S303AH	Armaturen Umrandung incl. Halteclips	moulding, instrument panel	BN4, BN6, BN7, BT7, BJ7	1
S304AH	Umrandung Lenksäule nicht einstellbar	escutcheon, steering column	BN4, BN6, BN7, BT7, BJ7	8
S305AH	Umrandung einstellbare Lenksäule	escutcheon, adjustable steering	BN4, BN6, BN7, BT7, BJ7	1
S306AH	Halteplatte an Armaturenbrett	plate escutcheon retaining	BN1, BN2, BN4, BN6, BN7, BT7, BJ7	1
S307AH	Holzverstärkung für Armaturenbrettgriff	packing block, wood	BN1-BJ7	1
S309AH/S	Velours an Armaturenbrett schwarz	edge trim, dashboard, black	BN4, BN6, BN7, BT7, BJ7	A/R
S309AH/B	Velours an Armaturenbrett blau	edge trim, dashboard, blue	BN4, BN6, BN7, BT7, BJ7	A/R
S309AH/R	Velours an Armaturenbrett rot	edge trim, dashboard, red	BN4, BN6, BN7, BT7, BJ7	A/R
i500AH/BN1-L	Armaturenbrett LHD Aluminium	dash panel LHD, aluminum	BN1, BN2	1
i500AH/BN1-R	Armaturenbrett RHD Aluminium	dash panel RHD, aluminum	BN1, BN2	1
i500AH/BN4-L	Armaturenbrett LHD Aluminium	dash panel LHD, aluminum	BN4, BN6, BN7, BT7, BJ7	1
i500AH/BN4-R	Armaturenbrett RHD Aluminium	dash panel RHD, aluminum	BN4, BN6, BN7, BT7, BJ7	1
i505AH	Blende Lüftungschlitze zur Scheibe	mask assembly, demister	BN1, BN2, BN4, BN6, BN7, BT7, BJ7	2
i505AH/C	Blende Lüftungschlitze chrom zur Scheibe	mask assembly, demister, chrome	BN1, BN2, BN4, BN6, BN7, BT7, BJ7	2
i507AH/BN4-S	Armaturenbrett-Verkleidung oben schwarz	dash top, padded, black	BN4, BN6, BN7, BT7	1
i507AH/BN4-B	Armaturenbrett-Verkleidung oben blau	dash top, padded, blue	BN4, BN6, BN7, BT7	1
i507AH/BN4-R	Armaturenbrett-Verkleidung oben rot	dash top, padded, red	BN4, BN6, BN7, BT7	1
i507AH/BJ8	Armaturenbrett-Verkleidung oben schwarz	dash top, padded, black	BJ7	1

Abb. zeigt rechtsgelenkte Ausführung / fig.: RHD illustrated

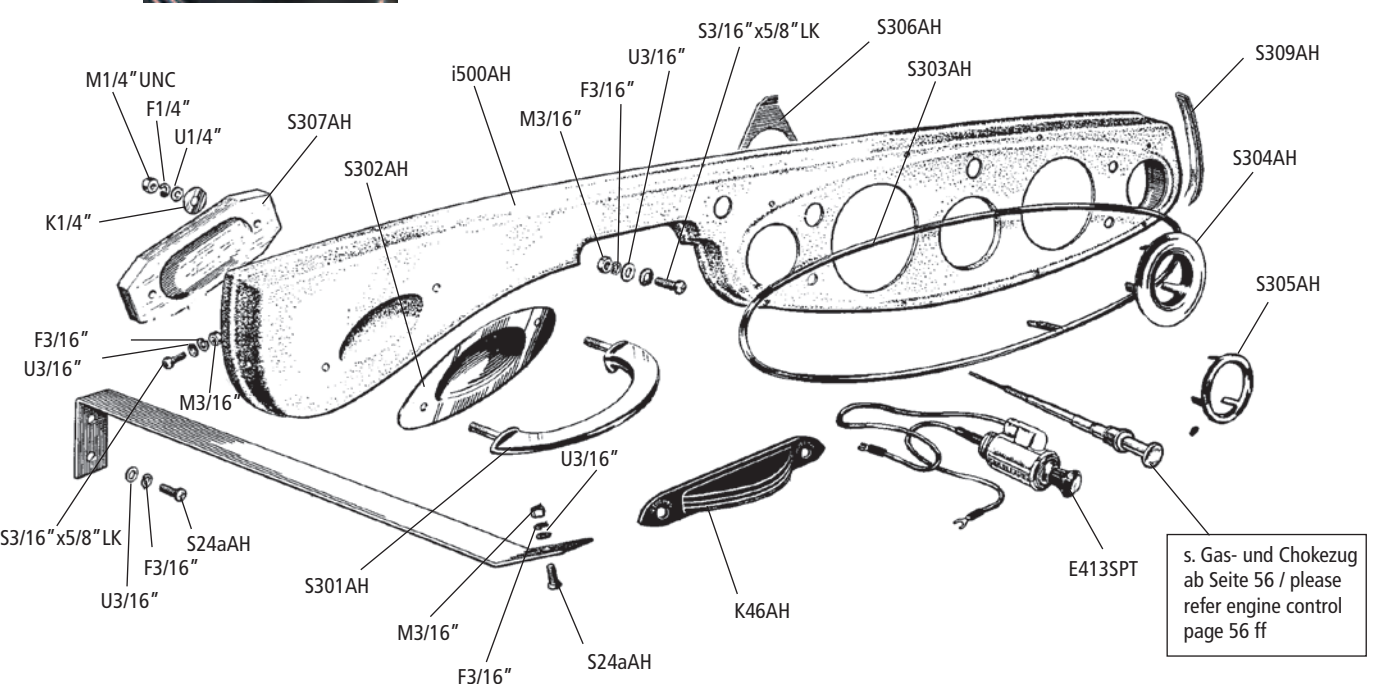
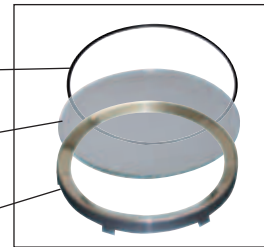
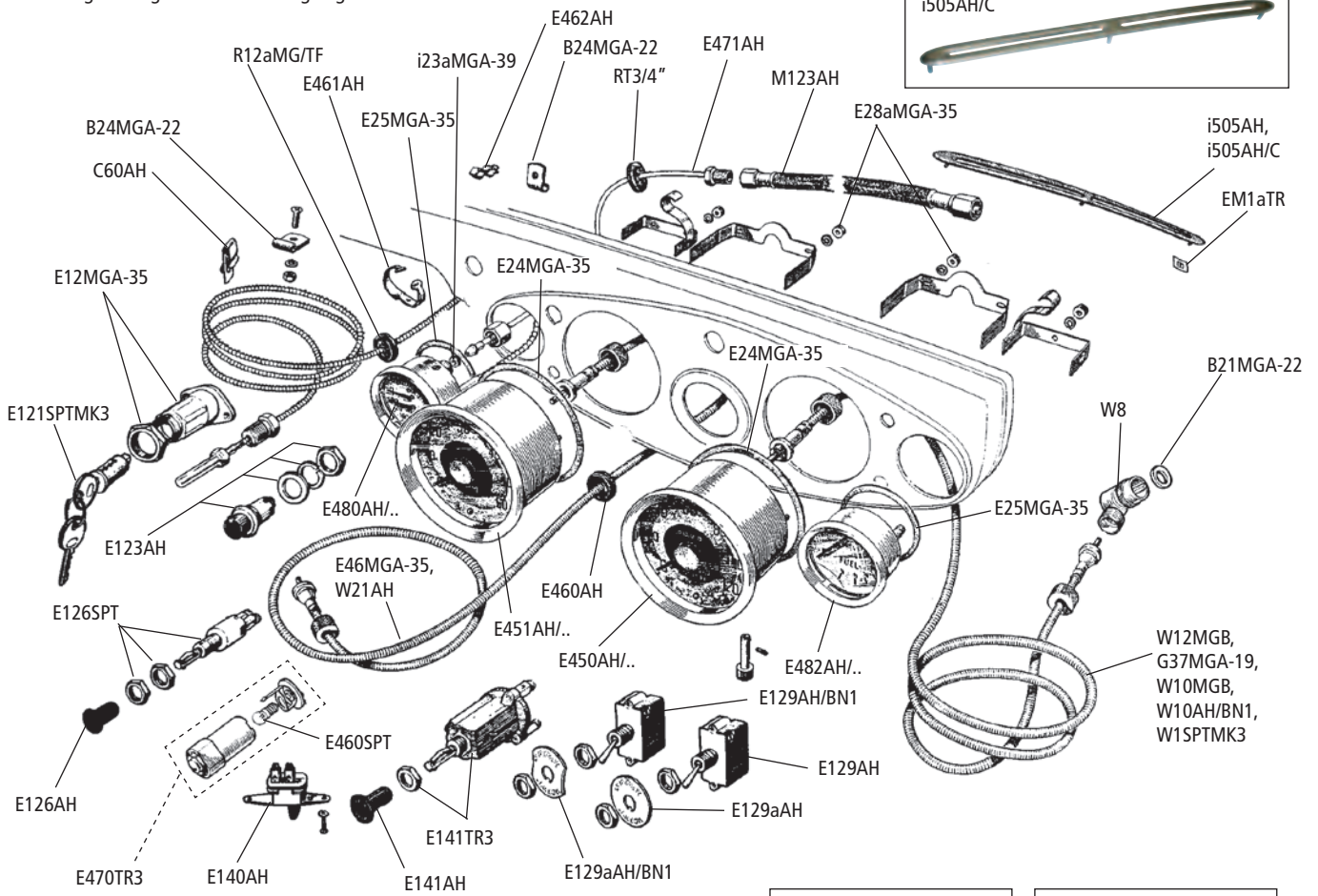

s. Gas- und Chokezug
ab Seite 56 / please
refer engine control
page 56 ff

No.	Bezeichnung	Description	Type	Anzahl/Req.
Schalter / Switch & Misc				
E12MGA-35	Elektroteil Zündschloß	switch body	BN1, BN2, BN4, BN6, BN7, BT7, BJ7	1
E121SPTMK3	Schließzylinder im Armaturenbrett	lock and two keys	BN1, BN2, BN4, BN6, BN7, BT7, BJ7	1
E123AH	Anlassertaster Armaturenbrett	switch, starter solenoid push	BN1, BN2, BN4, BN6, BN7, BT7, BJ7	1
E126SPT	Zugschalter Scheibenwischer	switch, windscreen wiper	BN1, BN2, BN4, BN6, BN7, BT7, BJ7	1
E126AH	Knopf Scheibenwischerschalter	knob, wiper switch	BN1, BN2, BN4, BN6, BN7, BT7, BJ7	1
E129AH/BN1	Overdrive Schalter im Armaturenbrett	switch, overdrive	BN1	1
E129aAH/BN1	Umrandung Oerdriveschalter	escutcheon, overdrive switch	BN1	1
E129AH	Overdrive Schalter im Armaturenbrett	switch, overdrive	BN2, BN4, BN6, BN7, BT7, BJ7	1
E129aAH	Umrandung Oerdriveschalter	escutcheon, overdrive switch	BN2, BN4, BN6, BN7, BT7, BJ7	1
E140AH	Schalter Armaturenbeleuchtung	switch, panel light	BN1, BN2, BN4, BN6, BN7, BT7, BJ7	1
E141TR3	Lichtschalter	switch, head and sidelamp	BN1, BN2, BN4, BN6, BN7, BT7, BJ7	1
E141AH	Knopf Lichtschalter	knob, lighting switch	BN1, BN2, BN4, BN6, BN7, BT7, BJ7	1
E413SPT	Zigarettenanzünder	cigarette lighter	BN1, BN2, BN4, BN6, BN7, BT7, BJ7	1
E460SPT	Birne Armaturenbrettbeleucht. mit Schraubgewinde	bulb, dash lamps	BN1, BN2, BN4, BN6, BN7, BT7, BJ7	1
E470TR3	Kontrolleuchte grün Blinker im Armaturenbrett mit Chromring	warning lamp & bezel, flasher	BN1, BN2, BN4, BN6, BN7, BT7, BJ7	1

Instrumente Benzin, Öldruck, Wassertemperatur / Fuel and Oil/Water Gauges

R12AMG/TF	Gummidurchführung f. Temperaturinstrument	grommet	BN1, BN2, BN4, BN6, BN7, BT7, BJ7	1
i23aMGA-39	Dichtring Leder	washer, leather	BN1, BN2, BN4, BN6, BN7, BT7, BJ7	1
B24MGA-22	Klammer Bremsleitung	clip, pipe	BN1, BN2, BN4, BN6, BN7, BT7, BJ7	A/R
E25MGA-35	Instrumenten-Dichtring „klein“	ring, sealing	BN1, BN2, BN4, BN6, BN7, BT7, BJ7	2
E27MGA-35	Instrumenten-Glass „klein“	glass	BN1, BN2, BN4, BN6, BN7, BT7, BJ7	2
C60AH	Klammer Brems-/Kupplungsleitung	clip, thermo capillary tube	BN7, BT7, BJ7	2
M123AH	Schlauch Öldruckanzeige	hose, flexible	BN7, BT7, BJ7	1
E461AH	Kabelbinder 6“	strap 6“	BN1, BN2, BN4, BN6, BN7, BT7, BJ7	1
E471AH/BN1-L	Öldruckleitung Instrument LHD	pipe, oil gauge, LHD	BN1, BN2	1
E471AH/BN1-R	Öldruckleitung Instrument RHD	pipe, oil gauge, RHD	BN1, BN2	1
E471AH	Öldruckleitung Instrument LHD	pipe, oil gauge, LHD	BN4, BN6, BN7, BT7, BJ7	1
E471AH/RHD	Öldruckleitung Instrument RHD	pipe, oil gauge, RHD	BN4, BN6, BN7, BT7, BJ7	1
E462AH	Befestigungsclip Leitung RHD	clip, pipe, RHD	BN1, BN2, BN4, BN6, BN7, BT7, BJ7	2
E480AH	Öldruck/Wassertemp-Instrument – Neuteil	oil/water gauge – new production	BN1-BJ7	1
E480AH/BN1 *	Öldruck/Wassertemp-Instr. Instandsetzung	oil/water gauge, exchange,	BN1-BN2	1
E480AH/BN4 *	Öldruck/Wassertemp-Instr. Instandsetzung	oil/water gauge, exchange,	BN4<68959, BN6<2029	1
E480AH/BN6 *	Öldruck/Wassertemp-Instr. Instandsetzung	oil/water gauge, exchange,	BN4>68960<72849, BN6>2030	1
E480AH/BT7 *	Öldruck/Wassertemp-Instr. Instandsetzung	oil/water gauge, exchange,	BN4>72850, BN7, BT7<14298	1
E480AH/BJ7 *	Öldruck/Wassertemp-Instr. Instandsetzung	oil/water gauge, exchange,	BN7/BT7>14299, BJ7	1
E482AH/BN1	Benzinuhr Instandsetzung FG2530/19	fuel gauge, exchange, FG2530/19	BN1, BN2	1
E482AH/BN4	Benzinuhr Instandsetzung FG253030/03	fuel gauge, exchange, FG253030/03	BN4, BN6, BN7, BT7, BJ7	1
E490SPT/52	Chromrand für Instrumente Ø 52mm	bezel, for gauges Ø 52mm	BN4, BN6, BN7, BT7, BJ7	2
RT3/4“	Tülle	grommet	BN4-BJ7	1

E116SPT



* Hinweis / Note:

Original Öldruck/Wassertemperatur Instrumente sind nicht mehr lieferbar. Diese Instrumente können aufbereitet werden. Lieferzeit ca. 6-8 Wochen. Preis nach Aufwand. Bitte fragen Sie nach!

Tipp:

Unsere neu angefertigten Instrumente in hochwertiger Qualität als Alternative – s. Seite 133

Original oil/water instruments are no longer available. Please ask for our service to rebuild the gauges. Price on demand!

Alternative – our advice:

from new production: our high quality instruments – please refer page 133

Abb. zeigt rechtsgelenkte Ausführung / fig.: RHD illustrated

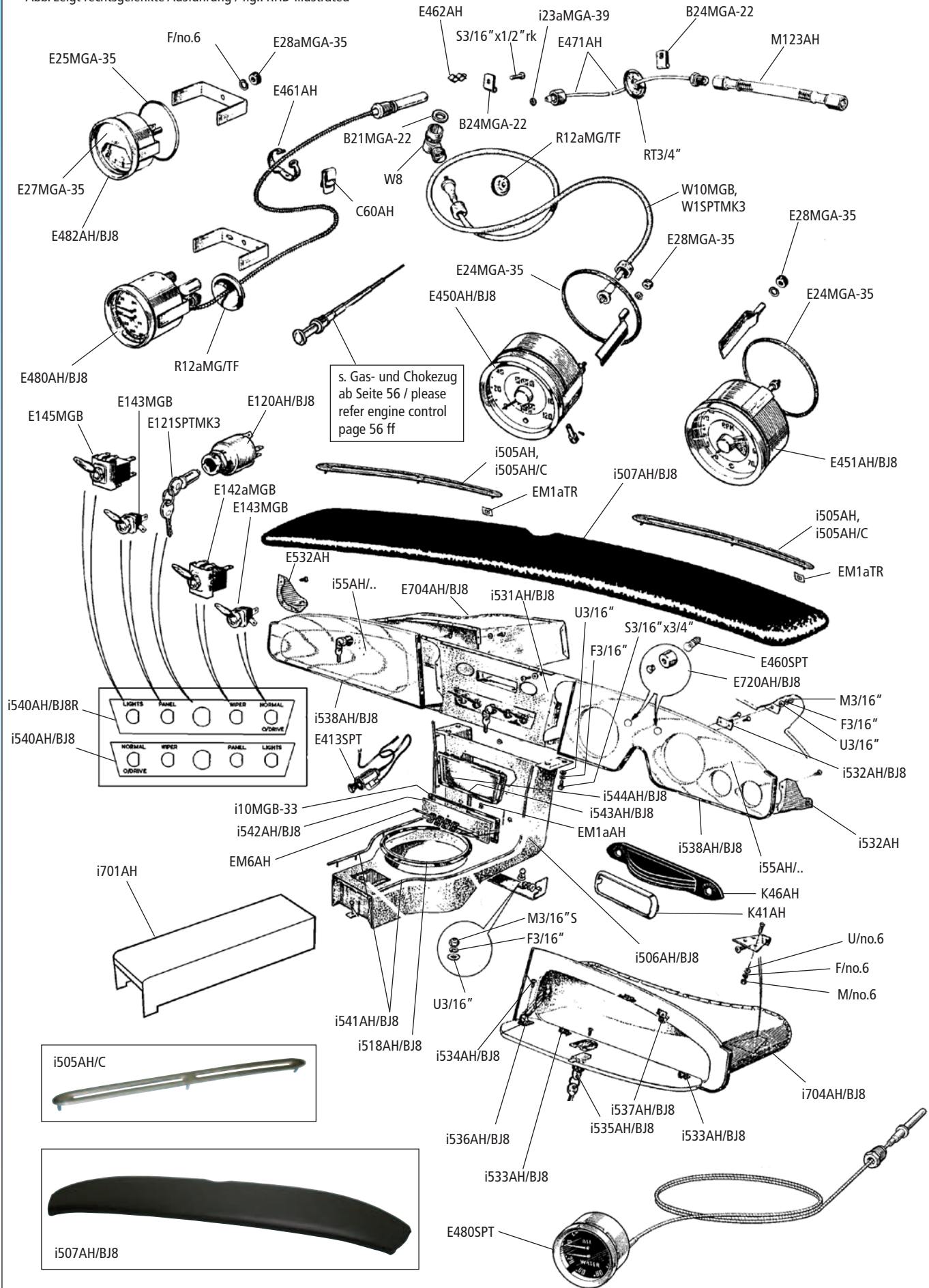

No.	Bezeichnung	Description	Type	Anzahl/Req.
Tachowelle und Drehzahlmesserwelle / Speedometer and Tachometer				
W1SPTMK3	Tachowelle mit Overdrive	speedometer, O/D	BJ8	1
W8	Winkelantrieb Tachowelle/Overdrive	angle drive, speedometer/OD	BJ8	1
W10MGB	Tachowelle ohne Overdrive	speedometer, w/o O/D	BJ8	1
B21MGA-22	Kupferscheibe 7/16"	washer, copper	BJ8	1
E24MGA-35	Instrumenten-Dichtring „groß“	ring, sealing	BJ8	1
E26MGA-35	Instrumenten-Glass „groß“	glass	BJ8	2
E28MGA-35	Rändelmutter Instrumentenbefestigung Tacho und Drehzahlmesser	nut, speedometer and tachometer	BJ8	4
E450AH/BJ8 *	Tachometer Instandsetzung ohne Overdrive SN6125/20 3.45:1	speedometer, exchange, w/o O/D SN6125/20 3.45:1	BJ8	1
E450AH/BJ8-OD *	Tachometer Instandsetzung mit Overdrive SN6125/22 3.909:1	speedometer, exchange, O/D SN6125/22 3.909:1	BJ8	1
E451AH/BJ8	Drehzahlmesser Instandsetzung RV12602/00	tachometer, exchange, RV12602/00	BJ8	1
E490SPT/100	Chromrand für Instrumente Ø 100mm	bezel, for gauges Ø 100mm	BJ8	2

Instrumente Benzin, Öldruck, Wassertemperatur / Fuel and Oil/Water Gauges

R12aMG/TF	Gummidurchführung f. Temperaturinstrument	grommet	BJ8	1
i23aMGA-39	Dichtring Leder	washe, leather	BJ8	1
B24MGA-22	Klammer Bremsleitung	clip, pipe	BJ8	1
E25MGA-35	Instrumenten-Dichtring „klein“	ring, sealing	BJ8	2
E27MGA-35	Instrumenten-Glass „klein“	glass	BJ8	2
E28aMGA-35	Rändelmutter Instrumentenbefestigung	nut	BJ8	4
C60AH	Klammer Brems-/Kupplungsleitung	clip pipe	BJ8	2
M123AH	Schlauch Öldruckanzeige	hose, flexible	BJ8	1
E461AH	Kabelbinder 6" (152mm)	strap 6"	BJ8	1
E462AH	Befestigungsclip Leitung	clip pipe	BJ8	2
E471AH	Öldruckleitung Instrument LHD	pipe, oil gauge LHD	BJ8	1
E471AH/BJ8RHD	Öldruckleitung Instrument RHD	pipe, oil gauge RHD	BJ8	1
E480AH/BJ8 *	Öldruck/Wassertemp. Instr. Instandsetzung, Fahrenheit	oil/water gauge, exchange, fahrenheit	BJ8	1
E480AH/BJ8-C *	Öldruck/Wassertemp. Instr. Instandsetzung, °Celsius	oil/water gauge, exchange, centigrad	BJ8	1
E482AH/BJ8	Benzinuhr Instandsetzung FG2333/10	fuel gauge, exchange, FG2333/10	BJ8	1
E490SPT/52	Chromrand für Instrumente Ø 52mm	bezel, for gauges Ø 52mm	BJ8	2
RT3/4"	Tülle Chokezug/Gaszug ø 19mm	grommet	BJ8	1

Schalter / Switch & Misc

E116SPT	Warnblinkanlage zum Nachrüsten	hazard warning unit	BJ8	1
E120AH/BJ8	Zündungs/Anlasser-Schalter	ignition switch	BJ8	1
E121SPTMK3	Schließzylinder im Armaturenbrett	lock and two keys	BJ8	1
E142aMGB	Scheibenwischerschalter einstufig	switch, windscreen wiper	BJ8	1
E143MGB	Schalter für OD Heizungsgebläse/Nebelschlußleuchte	switch, O/D / panel light	BJ8	1
E145MGB	Kippschalter	switch, head and sidelamp	BJ8	1
E460SPT	Birne Armaturenbrettbeleuchtung m. Schraubgewinde	bulb, dashlamps	BJ8	7/8
E720AH/BJ8	Blinker-Kontroll-Lampe	lens & cover, warning lamp	BJ8	2

* Beachten Sie bitte den Hinweis auf Seite 181. / Please pay attention to our note on page 181:



Abb. zeigt rechtsgelenkte Ausführung / fig.: RHD illustrated



No.	Bezeichnung	Description	Type	Anzahl/Req.
Armaturenbrett / Dashboard and Fittings				
EM1ATR	Halteclip	nut, spire	BJ8	6
EM1aAH	Klammer	fixing, badge	BJ8	2
EM6AH	Abzeichnen „3000“ + Pfeil	motif „3000“ + arrow	BJ8	1
i10MGB-33	Chromrand Radioöffnung	bezel, radio aperture surround	BJ8	1
B24MGA-21	Stopfen	plug	BJ8	1
K41AH	Blende Heizungsschieber	bezel, control panel aperture	BJ8	1
K46AH	Schieberblende Heizung	control panel, heater	BJ8	1
i55AH-WH	Armaturenbrett Wurzelholz LHD	dashboard set, walnut veneer LHD	BJ8	1
i55AH-WH/RHD	Armaturenbrett Wurzelholz RHD	dashboard set, walnut veneer RHD	BJ8	1
i55AH-ELM	Armaturenbrett Elm	dashboard set, Elm	BJ8	1
E413SPT	Zigarettenanzünder	cigarette lighter	BJ8	1
E480SPT	Doppelinstrument Wassertemp. + Öldruckinstr. schwarzes Ziffernblatt	double instrument water temperature + oil pressure	BJ8	1
i505AH	Blende Lüftungsschlitze zur Scheibe	finisher, defroster	BJ8	2
i505AH/C	Blende Lüftungsschlitze chrom zur Scheibe	finisher, defroster, chrome	BJ8	2
i506AH/BJ8	Mittelkonsole (unverkleidet)	console (untrimmed)	BJ8	1
i507AH/BJ8	Armaturenbrett-Verkleidung oben schwarz	dash top, padded, black	BJ8	1
i518AH/BJ8	Umrandung Schaltmuffe	bezel, gear lever	BJ8	1
i531AH/BJ8	Armaturenbrett Mittelteil	dash, panel center	BJ8	1
i532AH	Halter Armaturenbrett Paar	end bracket set	BJ8	1
i532AH/BJ8	Platte mit Stehbolzen für Armaturenbrett	stud plate	BJ8	2
i533AH/BJ8	Scharnier Handschuhfachdeckung + Armlehne	hinge, glove box	BJ8<26704	2
i534AH/BJ8	Schraube Umrandung + Scharniere Handschuhkastendeckel	screw	BJ8	2
i535AH/BJ8	Handschuhkastenschloß	lock, glove box (with 2 keys)	BJ8	1
i536AH/BJ8	Halter Handschuhfachdeckel	stay, glove box lid	BJ8	1
i537AH/BJ8	Anschlaggummi Handschuhfach-Deckel	buffer, lid	BJ8	1
i538AH/BJ8	Zierleisten (2) Armaturenbrett LHD	finisher set, dashboard LHD	BJ8	1
i538AH/BJ8-R	Zierleisten (2) Armaturenbrett RHD	finisher set, dashboard RHD	BJ8	1
i540AH/BJ8	Schalterleiste für Fahrzeuge mit Overdrive LHD	switch bezel, LHD with overdrive	BJ8	1
i540AH/BJ8-R	Schalterleiste für Fahrzeuge mit Overdrive RHD	switch bezel, RHD with overdrive	BJ8	1
i541AH/BJ8	Chrom-Zierleiste Konsole (Paar) Armlehne m. Scharnier	finisher pair, console, hinged arm rest	BJ8< 26704	1
i541aAH/BJ8	Chrom-Zierleiste Konsole (Paar) Armlehne feststehend	finisher pair, console, fixed arm rest	BJ8>26705	1
i542AH/BJ8	Abdeckblende, wenn kein Radio montiert	radio blanking plate	BJ8	1
i543AH/BJ8	Umrandung Lautsprecher	bezel, speaker surround	BJ8	1
i544AH/BJ8	Drahtnetz Radioblende	speaker mesh	BJ8	1
i701AH/F	Armlehne (unverkleidet) klappbar	base, arm rest, hinged	BJ8< 26705	1
i701AH	Armlehne (unverkleidet) feststehend	base, arm rest, fixed	BJ8>26706	1
E704AH/BJ8	Handschuhfach LHD	glove box, LHD	BJ8	1
E704AH/BJ8RHD	Handschuhfach RHD	glove box, RHD	BJ8	1

*** Hinweis**

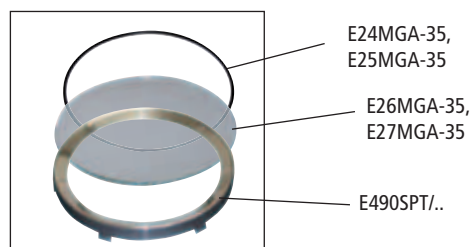
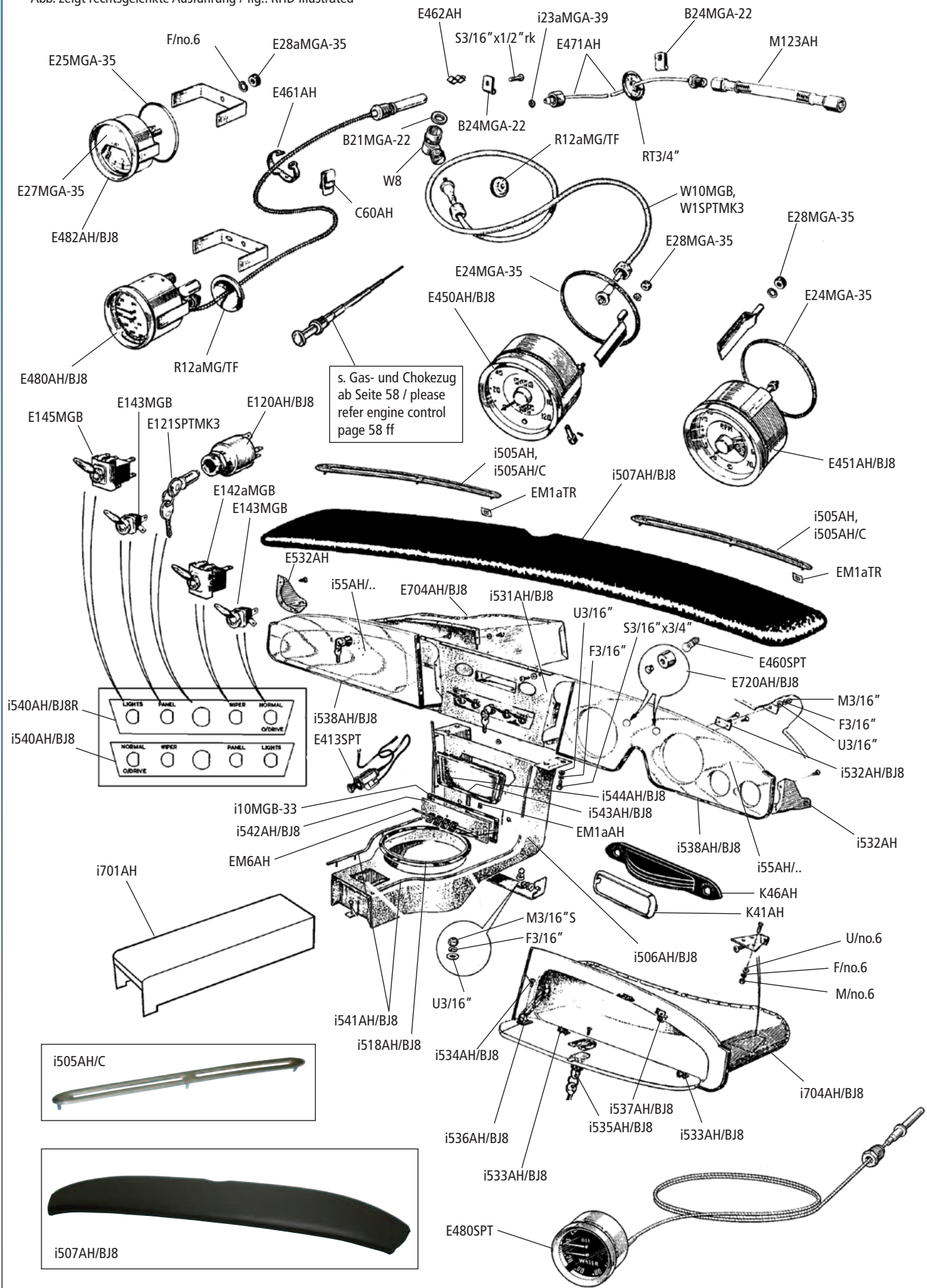
Original Tachometer bzw. Öldruck/Wassertemperatur Instrumente für BJ8 sind nicht mehr lieferbar. Diese Instrumente können aufbereitet werden. Lieferzeit ca. 6-8 Wochen. Preis nach Aufwand. Bitte fragen Sie nach!

Tipp:

Beachten Sie unsere neu angefertigten Instrumente in hochwertiger Qualität als Alternative – s. Seite 133

Note:

Original speedometer and oil/water instruments for BJ8 models are no longer available. Please ask for our service to rebuild the gauges. Price on demand!

Alternative – our advice:

from new production: our high quality instruments – please refer page 133

i55AH-ELM (Abb. zeigt linksgelenkte Ausführung / fig.: LHD illustrated)



E413SPT

Montageteile vorne / Front Body Fittings BN1, BN2

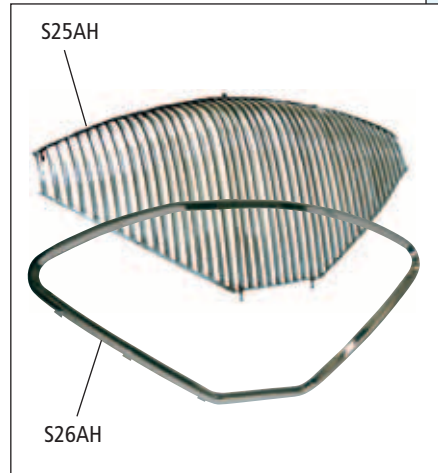
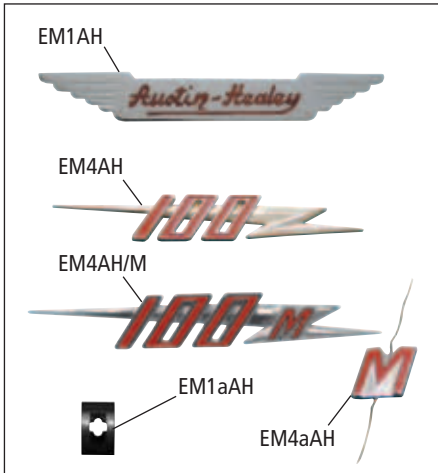
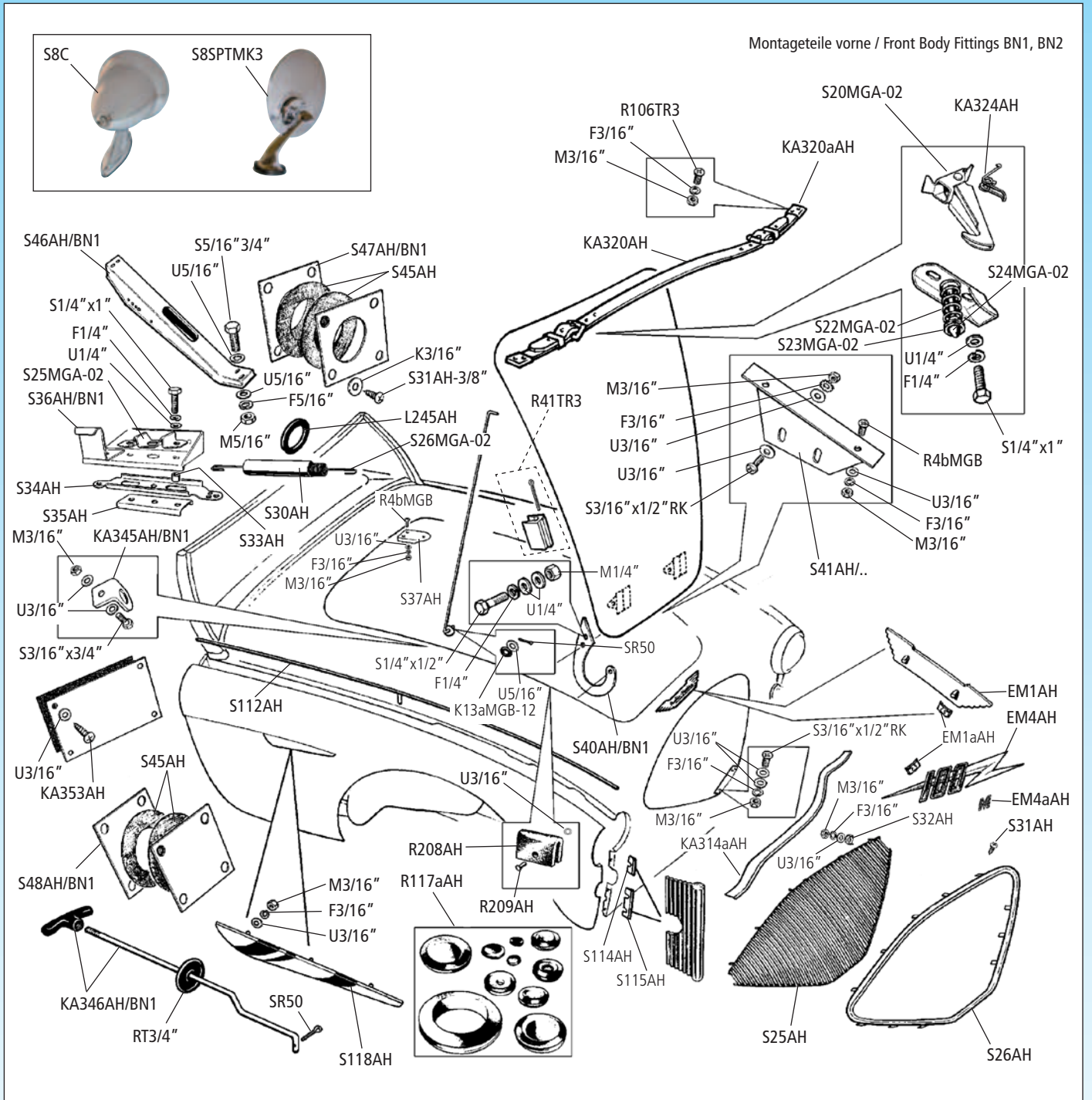

Montageteile vorne / Front Body Fittings BN1, BN2

No.	Bezeichnung	Description	Type	Anzahl/Qty.
EM1AH	Emblem vorne, geschraubt	front badge	BN1, BN2	1
EM1aAH	Klammer Schriftzüge	mounting clip	BN1, BN2	2
EM4AH	Emblem „100“ mit Pfeil Kühlergrill	front badge - "100" - radiator grille	BN1, BN2	1
EM4AH/M	Emblem „100/M“ mit Pfeil Kühlergrill	front badge - "100/M" - radiator grille	BN1, BN2 "Le Mans"	1
EM4aAH	Buchstabe „M“ Kühlergrill	front letter - "M" - radiator grille	BN1, BN2	1
R4bMGB	Senkkopfschraube kurz 3/16"x5/8"UNF	countersunk screw 3/16"x5/8"UNF	BN1, BN2	4
S8C	Sport-Spiegel	mirror, racing style	BN1, BN2	A/R
S8SPTMK3L	Außenspiegel rund „Lucas-Typ“ links	mirror, round, „Lucas style“ LH	BN1, BN2	1
S8SPTMK3R	Außenspiegel rund „Lucas-Typ“ rechts	mirror, round, „Lucas style“ RH	BN1, BN2	1
K13aMGB-12	Gummibüchse	ferrule, rubber	BN1, BN2	1
KA24AH/BN1	Typenschild	plate, chassis ID	BN1, BN2	1
KA41SPT	Blanko Typenschild deutsch	identification plate, blank (german)	BN1, BN2	1
S20MGA-02	Sicherungsbügel Motorhaube	hook assembly, hood	BN1, BN2	1
S22MGA-02	Feder Motorhaubenöffner	spring, striker pin	BN1, BN2	1
S23MGA-02	Federauflage Motorhaubenverschluss	striker pin	BN1, BN2	1
S24MGA-02	Zentrierstift Motorhaubenverschluss	cup	BN1, BN2	1
S25AH	Kühlergrill	grille	BN1, BN2	1
S25MGA-02	Falle Motorhaubeverschluss	plate, guide	BN1, BN2	1
S26AH	Umrandung Kühlergrill	frame, grille	BN1, BN2	1
S26MGA-02	Spannungsfeder Motorhaubenfalle	spring, tension, hood catch	BN1, BN2	1
S3/16"x1/2"RK	Rundkopf-Schraube 3/16 x 1 /2" UNF	screw 3/16 x 1 /2" UNF	BN1, BN2	4
S30AH	Abdeckung Feder Motorhaubenöffner	sleeve, spring	BN1, BN2	1
S31AH	Schraube selbstschneidend NO6x1/4"	screw, plate NO6x1/4"	BN1, BN2	12
S31AH-3/8	Schraube selbstschneidend NO6x3/8"	screw, plate NO6x3/8"	BN1, BN2	16
S32AH	Scheibe mit Krallen Kühlergrillbefestigung	U-clips	BN1, BN2	5
S33AH	Distanzrohr Motorhaubenöffner	tube, distance	BN1, BN2	2
S34AH	Schiebestück Motorhaubenfalle	slider, hood catch	BN1, BN2	1
S35AH	Halter für Schiebestück	slider support assembly	BN1, BN2	1
S36AH/BN1	Aufnahme für Falle Motorhaubenverschluss	support, hood latch	BN1, BN2	1
S37AH	Halter für Feder	retainer, tension spring	BN1, BN2	1
S40AH/BN1	Motorhaubenscharnier	arm, hood ringe	BN1, BN2	2
S41AH/100M	Halterung links	bracket, shroud LH	BN1, BN2	1
S41AH/BN1L	Halterung links	bracket, shroud LH	BN1, BN2	1
S41AH/BN1R	Halterung rechts	bracket, shroud RH	BN1, BN2	1
R41TR3	Haltegummi Motorhaube inkl. Splint	clip, rubber, hood prop rod incl. split pin	BN1, BN2	1
S45AH	Filz Abdichtung Verschlussdeckel Motorraum	felt, sealing and blanking plates	BN1, BN2	4
S46AH/BN1	Halter Lenksäule	bracket, steering column	BN1, BN2	1
S47AH/BN1	Abdeckplatte Lenksäulenabdichtung / Edelstahl	plate, steering column sealing, inner stainless steel	BN1, BN2	2
S48AH/BN1	Verschlussplatte Lenksäulendurchführung / Edelstahl	plate, steering column blanking, outer stainless steel	BN1, BN2	2
SR50	Splint	split pin	BN1, BN2	1
R106TR3	Chromschraube	screw, chrome	BN1, BN2	4
S112AH	Kederleiste Kotflügel	beading, front fender	BN1, BN2	2
S114AH	Keder oberhalb Blinker	beading, upper fender joint	BN1, BN2	2
S115AH	Keder unter Blinkleuchte	beading, lower fender joint	BN1, BN2	2
R117aAH	Gummi-Stopfen-Satz Spritzwand	grommet and plug set, bulkhead	BN1, BN2	1
S118AH/L	Zierblende Kotflügel links	flash LH	BN1, BN2	1
S118AH/R	Zierblende Kotflügel rechts	flash RH	BN1, BN2	1
R208AH	Anschlaggummi	buffer, rubber	BN1, BN2	6
R209AH	Stift für Anschlaggummi	rivet, buffer to hood surround	BN1, BN2	6
L245AH	Gummi-Durchführung Lenksäule	grommet, bulkhead, steering column	BN1, BN2	2
KA314aAH	Kederband	piping front apon	BN1, BN2	1
KA320aAH	Chrom-Halter Riemen Motorhaube Paar	fixing plate set, hood strap	BN1, BN2	1
KA320AH	Leder-Riemen Aluhaube	strap assembly, hood safety	BN1, BN2	1
KA324AH	Feder Motorhaubenhaken	spring	BN1, BN2	1
KA344AH/BN1	Aufstellstange Motorhaube	rod, hood prop	BN1, BN2	1
KA345AH/BN1	Halter Motorhaube-Aufstellstange	bracket, pivot, hood prop rod	BN1, BN2	1
KA346AH/BN1	Entriegelungstange Motorhaube incl. Griff	bracket incl. knob, hood lock support/rod	BN1, BN2	1
KA353AH	Schraube selbstschneidend	screw	BN1, BN2	2
RT3/4"	Tülle Chokezug/Gaszug Ø 19mm	grommet Ø 19mm	BN1, BN2	1

Montageteile vorne / Front Body Fittings BN4-BJ8

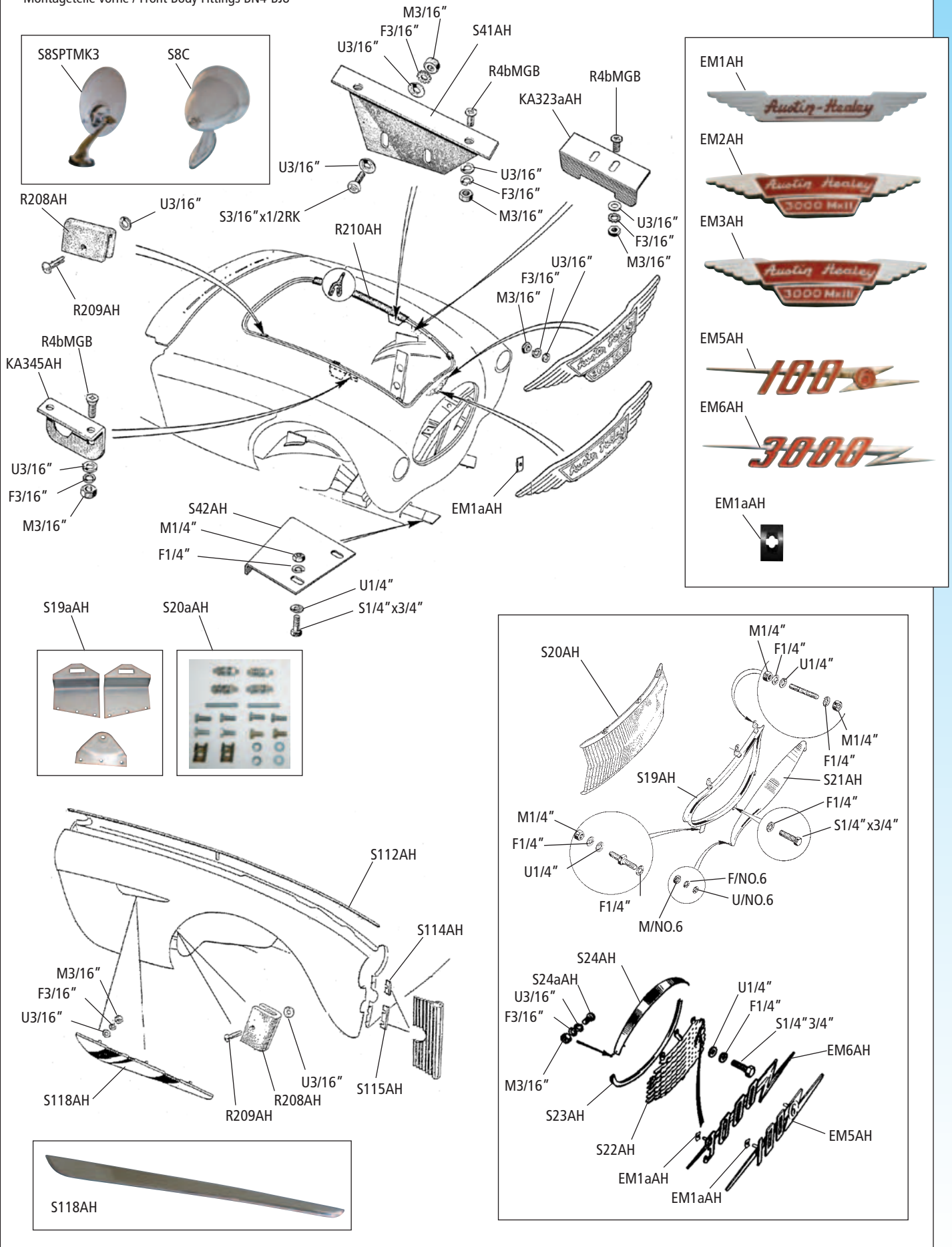

Montageteile vorne / Front Body Fittings BN4-BJ8

No.	Bezeichnung	Description	Type	Anzahl/Qty.
EM1AH	Abzeichen Motorhaube	front badge	BN4, BN6, BN7/BT7 < 13750	1
EM1aAH	Klammer Schriftzüge	mounting clip	BN4, BN6, BN7/BT7 < 13750	2
EM2AH	Abzeichen Motorhaube	front badge	BN7, BT7 ab 13751, BJ7	1
EM3AH	Abzeichen Motorhaube emailliert	front badge	BJ8	1
R4bMGB	Senkkopfschraube 3/16" x5/8" UNF	countersunk screw 3/16" x5/8" UNF	BN4, BN6, BN7, BT7, BJ7, BJ8	10
S19aAH	Halter Grill	shroud set	BN7/BT7 ab 13751 BJ7, BJ8	3
S41aHL	Halterung links	bracket, shroud support LH	BN4, BN6, BN7, BT7, BJ7, BJ8	1
S41aHR	Halterung rechts	bracket, shroud support RH	BN4, BN6, BN7, BT7, BJ7, BJ8	1
S42aHL	Halterung Rahmen links	bracket, shroud to chassis LH	BN4, BN6, BN7, BT7, BJ7, BJ8	1
S42aHR	Halterung Rahmen rechts	bracket, shroud to chassis RH	BN4, BN6, BN7, BT7, BJ7, BJ8	1
SR50	Splint	split pin	BN4-BJ8	
R208AH	Anschlaggummi	buffer, rubber	BN7, BT7 ab 13751	5/4
R209AH	Stift für Anschlaggummi	rivet, buffer to hood surround	BN7, BT7 ab 13751	5/4
R210AH	Kantenschutzgummi Motorhaube	strip, hood surround sealing	BN4-BJ8	1
KA323aAH	Halter Sicherungsbügel Motorhaube	bracket, pivot, hood prop rod	BN4, BN6, BN7, BT7, BJ7, BJ8	2
KA345AH	Halter Motorhaube-Aufstellstange	bracket, stay, hood rod prop	BN6, BN7, BT7, BJ7, BJ8	1
S3/16"x1/2"RK	Rundkopf-Schraube 3/16 x 1/2" UNF	screw 3/16 x 1/2" UNF	BN4, BN6, BN7, BT7, BJ7, BJ8	4
EM1aAH	Klammer Schriftzüge	mounting clip	BN4, BN6, BN7/BT7 < 13750	2
EM5AH	Abzeichen Kühlergrill „100/6“	front flash -"100/6" - radiator grille	BN4, BN6, BN7/BT7 < 13750	1
EM6AH	Abzeichen „3000“ mit Pfeil	front flash -"3000"	BN4, BN6, BN7/BT7 < 13750	1
S19AH	Umrandung Kühlergrill	surround, grille	BN7/BT7 ab 13751 BJ7, BJ8	1
S20AH	Kühlergrill Mittelteil	radiator grille centre	BN7/BT7 ab 13751 BJ7, BJ8	1
S20aAH	Kühlergrill Befestigungssatz	mounting kit, grille	BN7/BT7 ab 13751 BJ7, BJ8	1
S21AH	Kühlergrill Oberteil	radiator grille top	BN7/BT7 ab 13751 BJ7, BJ8	1
S22AH	Kühlergrill Mittelteil	radiator grille centre	BN4, BN6, BN7/BT7 < 13750	1
S23AH	Zierleiste Grill unten	radiator grille bottom	BN4, BN6, BN7/BT7 < 13750	1
S24AH	Kühlergrill Oberteil	radiator grille topscrew 3/16"x1/2" UNF,	BN4, BN6, BN7/BT7 < 13750	1
S24aAH	Chromschraube 3/16"x1/2" UNF	chrome	BN4, BN6, BN7/BT7 < 13750	2
S8C	Sport-Spiegel	mirror, racing style	BN4-BJ8	2
S8SPTMK3L	Außenspiegel rund „Lucas-Typ“ links	mirror, round, „Lucas style“ LH	BN4-BJ8	1
S8SPTMK3R	Außenspiegel rund „Lucas-Typ“ rechts	mirror, round, „Lucas style“ RH	BN4-BJ8	1
S112AH	Kederleiste Kotflügel vorne	beading, front fender	BN4-BJ8	2
S114AH	Keder oberhalb Blinker	beading, upper fender joint	BN4-BJ8	2
S115AH	Keder unter Blinkleuchte	beading, lower fender joint	BN4-BJ8	2
S118AH/L	Zierblende Kotflügel links	flash LH	BN4-BJ8	1
S118AH/R	Zierblende Kotflügel rechts	flash RH	BN4-BJ8	1
R208AH	Anschlaggummi	buffer, rubber	BN4-BJ8	4
R209AH	Stift für Anschlaggummi	rivet, buffer to hood surround	BN4-BJ8	4

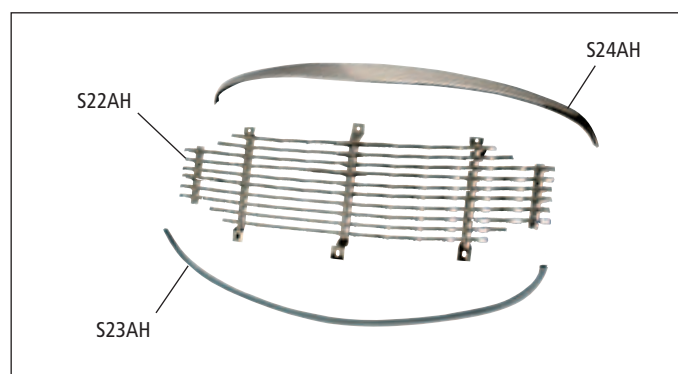
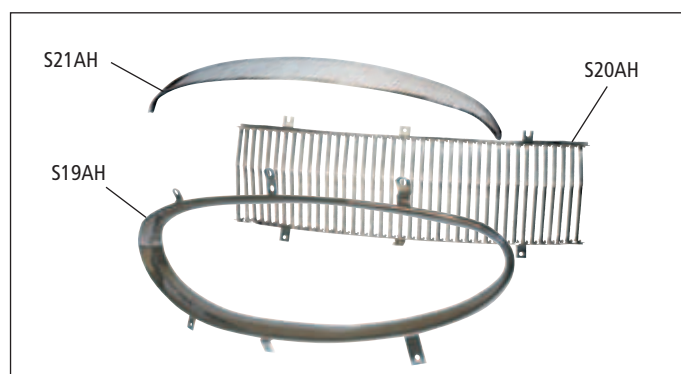

Montageteile vorne / Front Body Fittings BN4-BJ8

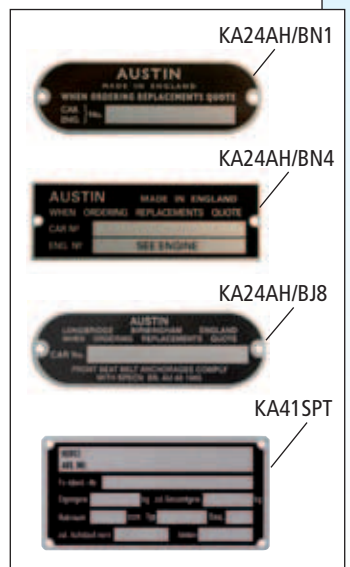
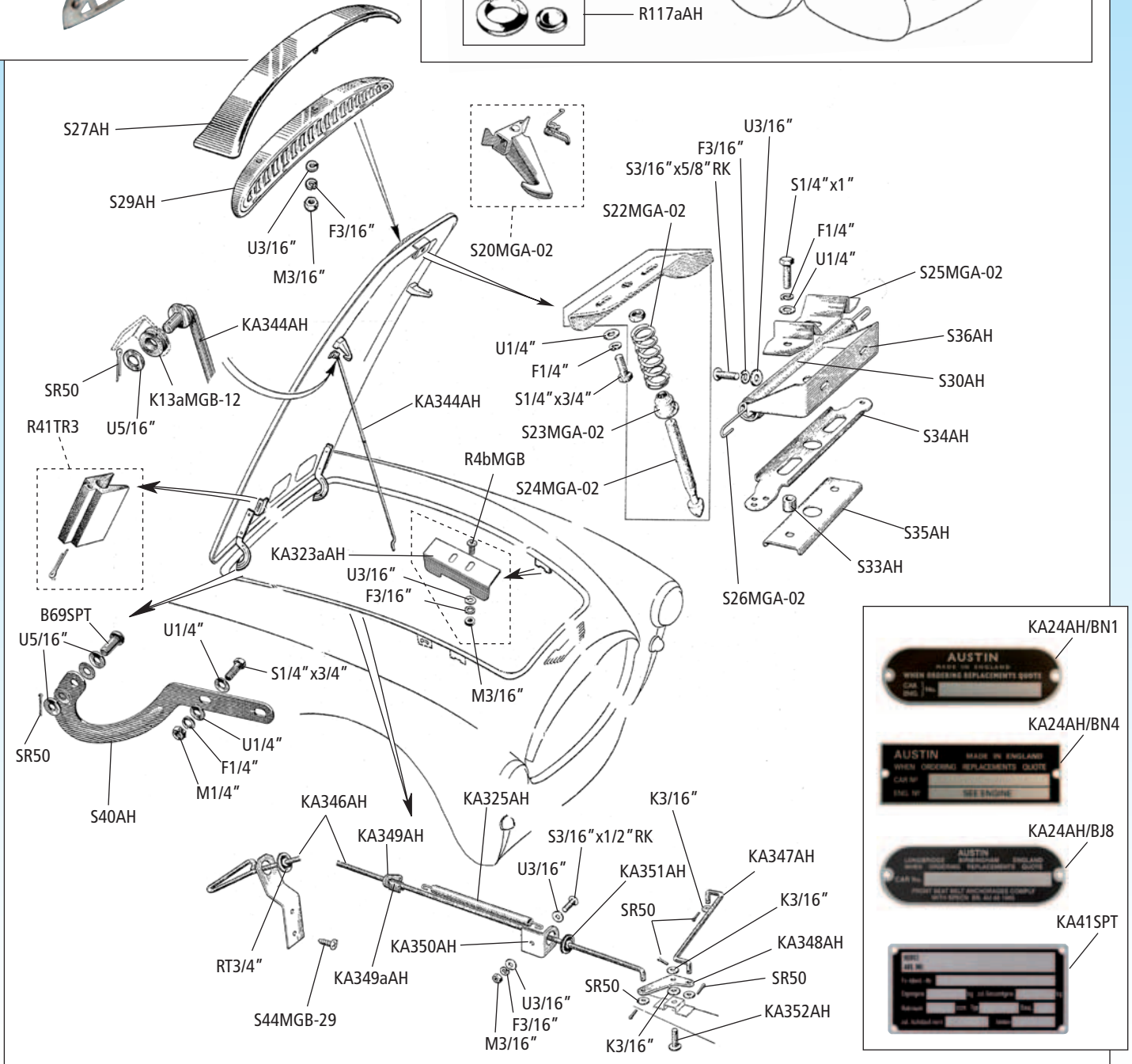
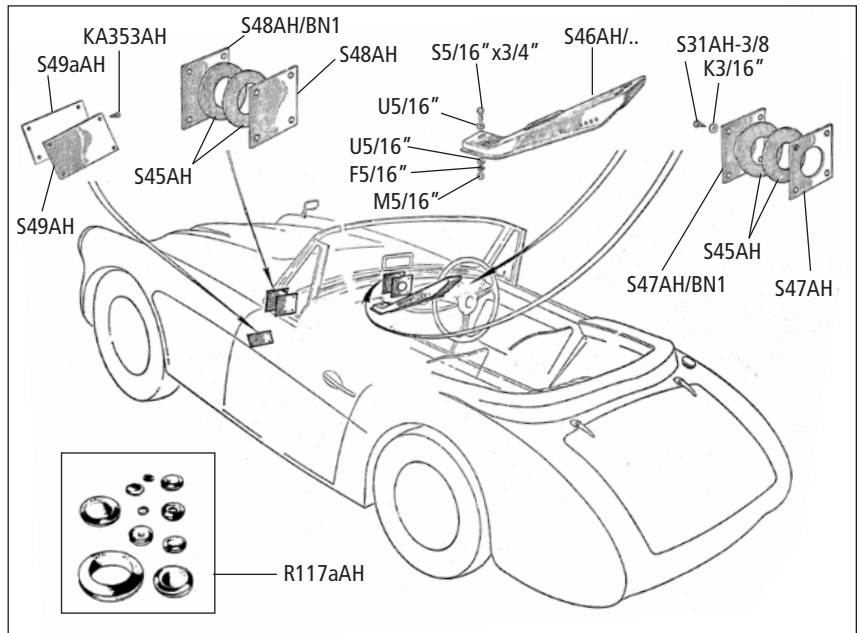

Montageteile vorne / Front Body Fittings BN4-BJ8

No.	Bezeichnung	Description	Type	Anzahl/Qty.
K13aMGB-12	Anschlaggummi	ferrule, rubber	BN4>68959,BN6,BN7,BT7,BJ7, BJ8	1
S20MGA-02	Sicherungsbügel Motorhaube	hook assembly, hood	BN4-BJ8	2
S27AH	Chrom-Blende auf Motorhaube	hood, grille	BN4 - BJ8	1
S28AH	Motorhaube-Gitter Mittelteil	grille, air intake	BN4, BN6, BN7/BT7<13750	1
S29AH	Motorhaube-Gitter Mittelteil	grille, air intake	BN7/BT7>13751 BJ7, BJ8	1
S40AHL	Scharnier Motorhaube links	hood hinge LH	BN4-BJ8	1
S40AHR	Scharnier Motorhaube rechts	hood hinge RH	BN4-BJ8	1
R41TR3	Haltegummi Motorhaube	rubber clip, hood rod prop	BN4-BJ8	1
SR50	Splint 1.6mm x32mm	cotter pin	BN4-BJ8	4
B69SPT	Bolzen 5/16"	clevis pin	BN4-BJ8	2
KA344AH	Aufstellstange Motorhaube	rod, hood prop	BN4>68959,BN6,BN7,BT7,BJ7, BJ8	1
S22MGA-02	Feder Motorhaubenöffner	spring, striker pin	BN4>68959,BN6,BN7,BT7,BJ7, BJ8	1
S23MGA-02	Federauflage Motorhaubenverschluss	cup	BN4>68959,BN6,BN7,BT7,BJ7, BJ8	1
S24MGA-02	Zentrierstift Motorhaubenverschluss	striker pin	BN4>68959,BN6,BN7,BT7,BJ7, BJ8	1
S25MGA-02	Falle Motorhaubenverschluss	plate, guide	BN4>68959,BN6,BN7,BT7,BJ7, BJ8	1
S26MGA-02	Spannungsfeder Motorhaubenfalle	spring, tension, hood latch	BN1-BJ8	1
S30AH	Abdeckung Feder Motorhaubenöffner	sleeve, spring	BN1-BJ8	1
S33AH	Distanz-Rohr Motorhaubenöffner	distance tube	BN1-BJ8	2
S34AH	Schiebestück Motorhaubenfalle	slider, hood catch	BN1-BJ8	1
S35AH	Halter für Schiebestück	slider, support assembly	BN4-BJ8	1
S36AH	Aufnahme für Falle Motorhaubenverschluss	bracket, hood latch support	BN4-BJ8	1
S44MGB-29	Rundkopfschraube 3/16"x1/2" UNF selbstschneidend	screw 3/16"x1/2" UNF		2
KA325AH	Feder Motorhaube	spring, anti-rattle	BN4-BJ8	1
KA346AH	Entriegelungstange Motorhaube	rod, hood latch remote control	BN4-BJ8	1
KA347AH	Entriegelungstange Motorhaube kurz	rod, connecting, lever to slider	BN4-BJ8	1
KA348AH	Entriegelungstange Umlenkung	lever	BN4-BJ8	1
KA349aAH	Halteclip an Halter Motorhaubenriegel	clip, retaining, ancor bracket	BJ7,BJ8	1
KA349AH	Halteplatte Feder Motorhaubenriegel	bracket, ancor	BN4-BJ8	1
KA350AH	Halter Zugstange Motorhaubenriegel	bracket, rod support, front	BN4-BJ8	1
KA351AH	Gummi Zugstange Motorhaubenriegel vorne	grommet, front support bracket	BN4-BJ8	1
KA352AH	Lagerstift 3/16"x7/8"	clevis pin, lever	BN4-BJ8	1
RT3/4"	Tülle Chokezug	grommet	BN4-BJ8	1
KA24AH/BN1	Typenschild	identification plate	BN1>219000, BN2, BN4 (Longbridge)	1
KA24AH/BN4	Typenschild	identification plate	BN4 (Abingdon Fahrzeuge),BN6, BN7, BT7	1
KA24AH/BJ8	Typenschild	identification plate	BJ7, BJ8	1
S31AH-3/8	Schraube selbstschneidend NO6x3/8"	screw NO6x3/8"	BN4-BJ8	16
KA41SPT	Blanko Typenschild deutsch	identification plate (german), blank	BN4-BJ8	1
S45AH	Filz Abdichtung Verschlussdeckel Motorraum	felt, sealing and blanking plates	BN4-BJ8	4
S46AH/BJ8	Halter Lenksäule	bracket, steering column	BN1-BJ8	1
S46AH/BN4	Halter Lenksäule	bracket, steering column	BJ7, BJ8 BN4,BN6,BN7,BT7	1
S47AH	Abdeckplatte Lenksäulenabdichtung Edelstahl	plate, steering column sealing, inner stainless steel	BN4-BJ8	1
S48AH	Verschlussplatte Lenksäulendurchführung Edelstahl	plate, steering column blanking, outer stainless steel	BN4-BJ8	1
S49aAH	Dichtung Verschlussplatte Pedalkasten	gasket, plate, pedal box	BN1, BN2, BN4-BJ8	1
S49AH	Verschlussplatte Pedalkasten Edelstahl	plate, pedal box blanking	BN4-BJ8	1
R117AAH	Gummi-Stopfen-Satz Spritzwand	grommet and plug kit, firewall	BN4-BJ8	1
KA353AH	Schraube selbstschneidend	screw, plate	BN1-BJ8	4

Montageteile Heck / Rear body fittings BN1, BN2

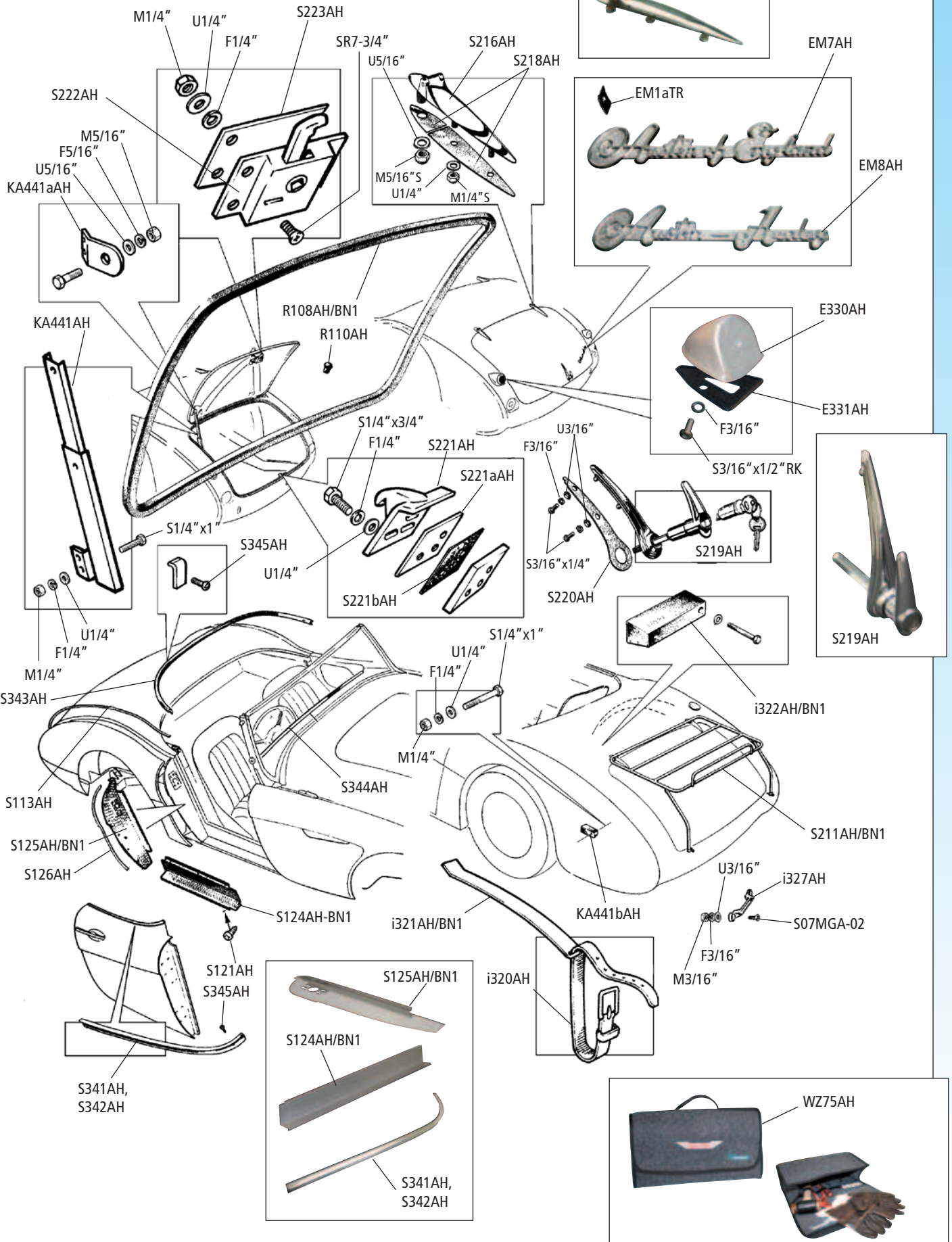

Montageteile Heck / Rear body fittings BN1, BN2

No.	Bezeichnung	Description	Type	Anzahl/Qty.
Fahrgastraum / Cockpit fittings				
S121AH	Satz Befestigungsschrauben für Türeinstieg	screw set, per side	BN1-BN2	2
S124AH-BN1/L	Schweller Verkleidung links	aluminium sell cover LH	BN1-BN2	1
S124AH-BN1/R	Schweller Verkleidung rechts	aluminium sell cover RH	BN1-BN2	1
S126AH	Paar Keder B-Säule	piping for pillow cover, pair	BN1-BN2	1
S341AH*	Zierleiste poliert auf Tür, rechts	door mouldng, polished RH	BN1-BN2	1
S342AH*	Zierleiste poliert auf Tür, links	door moulding polished LH	BN1-BN2	1
S343AH*	Zierleiste poliert auf Fahrgastraum, hinten	rear cockpit moulding	BN1-BN2	1
S344AH*	Zierleiste poliert auf Fahrgastraum, vorne	front cockpit moulding	BN1-BN2	1
S345AH	Befestigungsschraube für Zierleisten	srew, moulding attachment	BN1-BN2	22
Heck / Rear external fittings				
EM1aTR	Halteclip Embleme	fixing badge	BN1-BN2	3
EM7AH	Emblem "Austin of England" (BN1 früh)	badge "Austin of England" (BN1 early model)	BN1	1
EM8AH	Emblem "Austin Healey"	badge "Austin Healey"	BN1-BN2	1
S113AH	Keder Kotflügel hinten	beading rear wing	BN1-BN2	2
S211AH/BN1	Gepäckträger	luggage rack	BN1-BN2	1
S216AH/L	Kofferraumscharnier links	boot hinge LH	BN1-BN2	1
S216AH/R	Kofferraumscharnier rechts	boot hinge RH	BN1-BN2	1
S218AH	Kofferraumscharnier Unterlage	gasket boot hinge	BN1-BN2	2
S219AH	Kofferraumgriff und Schließzylinder	boot handle assembly with lock and 2 keys	BN1-BN2	1
S220AH	Unterlage Kofferraumgriff	boot handle gasket	BN1-BN2	1
E330AH/L	Gehäuse Reflektor links	reflector plinth LH	BN1-BN2	1
E330AH/R	Gehäuse Reflektor rechts	reflector plinth RH	BN1-BN2 wenn montiert / as fitted	1
E331AH	Gummiunterlage Gehäuse	plinth pad	BN1-BN2 wenn montiert / as fitted	2
Kofferraum Montageteile / Trunk internal fittings BN1, BN2				
S07MGA-02	Senkkopfschraube 3/16"x5/8" UNF	countersunk screw 3/16"x5/8" UNF	BN1-BN2	2
SR7-3/4"	Senkkopfschraube 1/4"x3/4" UNF	countersunk screw 1/4"x3/4" UNF	BN1-BN2	4
R108AH/BN1	Kofferraumdichtung, geklebt	boot seal (glues into channel)	BN1-BN2	1
R110AH	Gummi Anschlagstopfen	buffer boot lid	BN1-BN2	3
S221AH	Falle Kofferraumschloß	striker, boot lock	BN1-BN2	1
S221aAH	Unterlage Falle Kofferraumschloß	packing plate striker	BN1-BN2	1
S221bAH	Gewindeplatte für Falle Kofferraumschloß	plate, tapped	BN1-BN2	1
S222AH	Kofferraumschloß	boot lock	BN1-BN2	1
S223AH	Unterlage Kofferraumschloß	packing plate	BN1-BN2	1
i300AH/BN1	Kofferraum Ausstattungssatz	track lining kit	BN1-BN2	1
i320AH	Halteriemen Reserverad	stop assy spare wheel	BN1-BN2	1
i321AH/BN1	Reserverad Haltestange	retaining bar spare wheel	BN1-BN2	1
i322AH/BN1	Reserverad Halteklotz	block, spare wheel	BN1-BN2	1
i327AH	Chrom-Verschluss für Halteriemen	stuble, chrome strap retaining	BN1-BN2	1
KA441AH	Aufstellstange Kofferraumdeckel	stay boot lid	BN1-BN2	1
KA441aAH	Halter Aufstellstange	stay bracket	BN1-BN2	1
KA441bAH	Distanzstück Aufstellstange	block packing stay	BN1-BN2	1
WZ75AH	Werkzeugtasche (ohne Inhalt)	tool bag (w/o content)		

* Die Zierleisten werden poliert und mit etwas Überlänge geliefert. Die Zierleisten sind entsprechend anzupassen.

* These mouldings are supplied polished and slightly over-length. They must be trimmed to fit your particular car.

Weitere Teppichsätze s. Seite 216 /
More interior trim / carpets on page 216.



Montageteile Heck / Rear body fittings BN4, BN6, BN7, BT7, BJ8

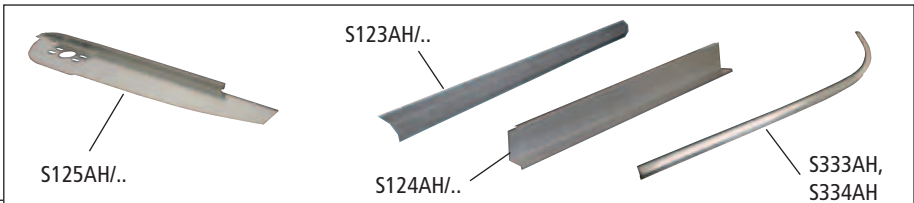
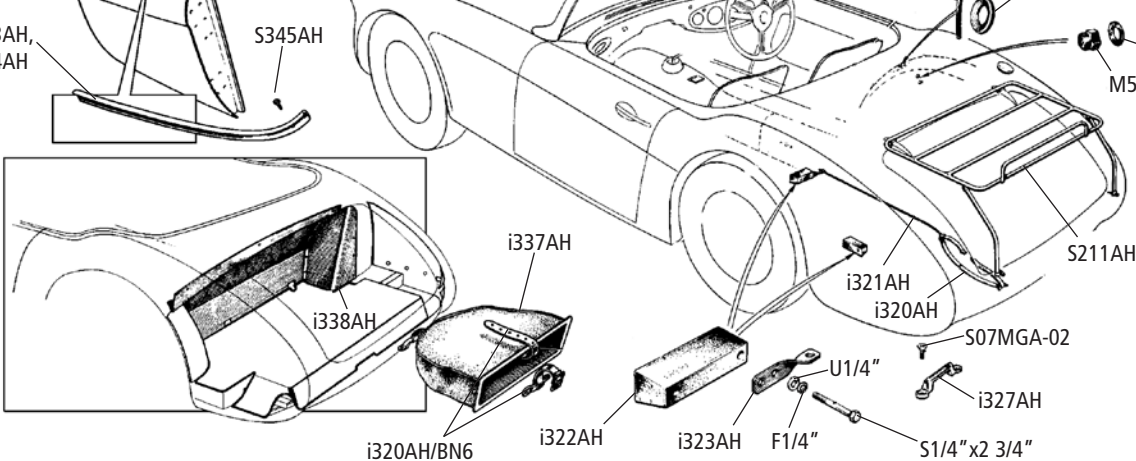
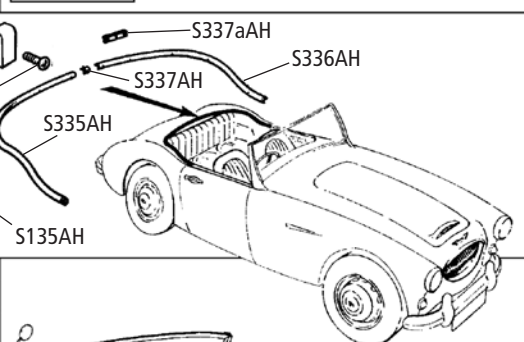
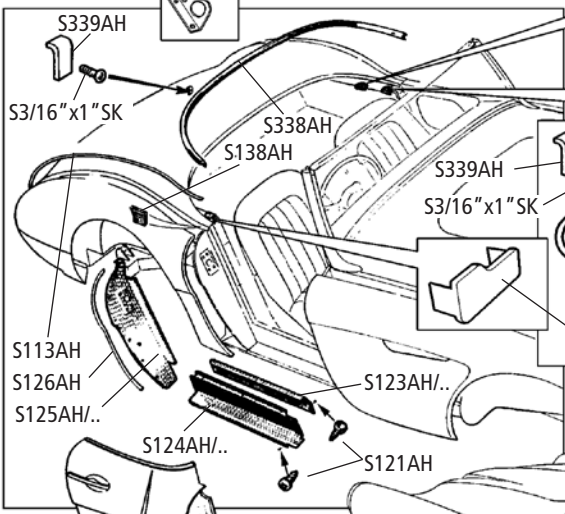
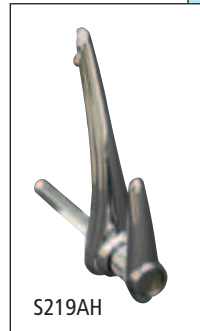
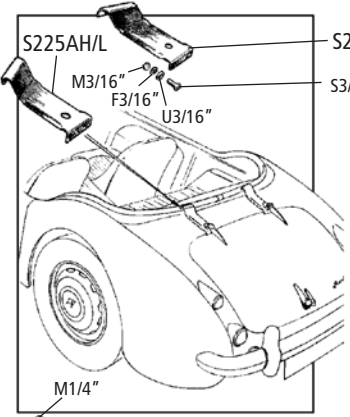
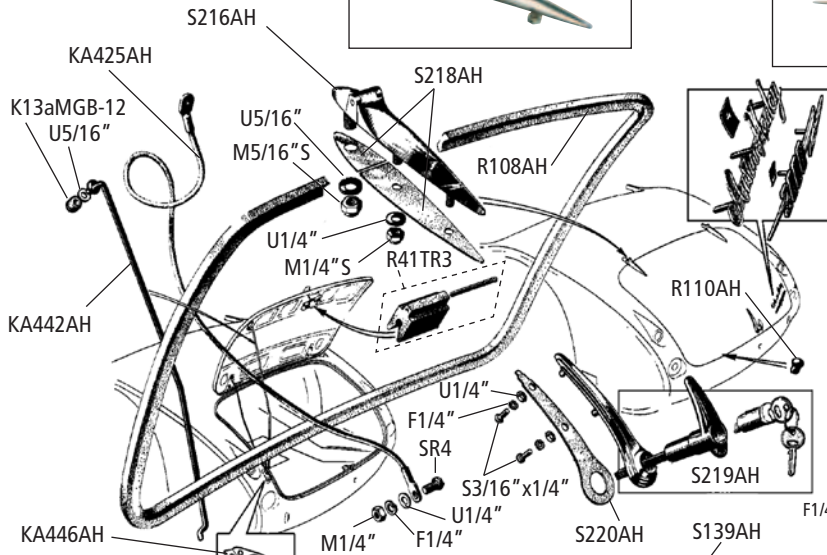
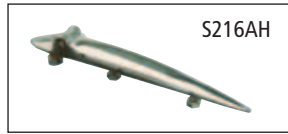
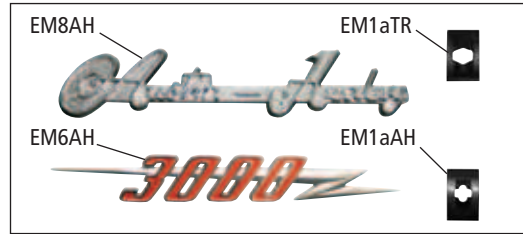

Montageteile Heck / Rear body fittings BN4, BN6, BN7, BT7, BJ7, BJ8

No.	Bezeichnung	Description	Type	Anzahl/Qty.
Fahrgastraum / Cockpit fittings				
K9SPT	Schlauchschelle	clip, drain tube	BJ7,BJ8	2/3
K34AH	Dichtgummi Ablaufschlauch	grommet, drain tube	BJ7,BJ8	2/3
S121AH	Satz Befestigungsschrauben für Türeinstieg	screw set per side	BN1-BJ8	2
S123AH/L	Abdeckleiste Türeinstiegskante links	aluminium carpet strip LH	BN4-BJ8	1
S123AH/R	Abdeckleiste Türeinstiegskante rechts	aluminium carpet strip RH	BN4-BJ8	1
S124AH-BN4/L	Aluminium Schweller Verkleidung links	aluminium sill cover LH	BN4<68959 (long bridge car)	1
S124AH-BN4/R	Aluminium Schweller Verkleidung rechts	aluminium sill cover RH	BN4<68959 (long bridge car)	1
S124AH-BJ8/L	Aluminium Schweller Verkleidung links	aluminium sill cover LH	BN4>68960,BN6,BT7,BJ7,BJ8	1
S124AH-BJ8/R	Aluminium Schweller Verkleidung rechts	aluminium sill cover RH	BN4>68960,BN6,BT7,BJ7,BJ8	1
S125AH-BN4/L	Aluminium Verkleidung B-Säule links	aluminium shut pillar cover LH	BN4<68959 (long bridge car)	1
S125AH-BN4/R	Aluminium Verkleidung B-Säule rechts	aluminium shut pillar cover RH	BN4<68959 (long bridge car)	1
S125AH-BN6/L	Aluminium Verkleidung B-Säule links	aluminium shut pillar cover LH	BN4>68960,BN6,BT7,BJ7,BJ8	1
S125AH-BN6/R	Aluminium Verkleidung B-Säule rechts	aluminium shut pillar cover RH	BN4>68960,BN6,BT7,BJ7,BJ8	1
S125AH-BJ8/L	Aluminium Verkleidung B-Säule links	aluminium shut pillar cover LH	BJ7,BJ8	1
S125AH-BJ8/R	Aluminium Verkleidung B-Säule rechts	aluminium shut pillar cover RH	BJ7,BJ8	1
S126AH	Paar Keder B-Säulenverkleidung	piping for pillar cover, pair	BN4,BN6,BN7,BT7,BJ7,BJ8	1
S135AH	Paar Abdeckkappen B-Säule	cap, slut pillar, pair	BN4<68959 (long bridge car)	1
S137AH	Paar Chromkappen Türdichtgummis	cap, door seal, pair	BN4>68960,BN6,BT7	1
S138AH/L	Endstück Verkleidung seitlich links	finish rear quarter panel LH	BJ7,BJ8	1
S138AH/R	Endstück Verkleidung seitlich rechts	finish rear quarter panel RH	BJ7,BJ8	1
S139AH	Paar Umrandung Gestängeverkleidung	plank, bar socket finish, pair	BN6,BN7	1
M5/16"-H	Chrom Hutmutter für Sicherheitsgurte	chrome nut for seat belt	BN7,BT7,BJ7,BJ8	4
S140AH	Ablaufschlauch Wasserkanal Fahrgastraum	drain tube, cockpit water channel	BJ7,BJ8	2/3
S333AH*	Zierleiste poliert auf Tür oben rechts	door moulding top, polished RH	BN4,BN6,BN7,BT7	1
S334AH*	Zierleiste poliert auf Tür oben links	door moulding top, polished LH	BN4,BN6,BN7,BT7	1
S345AH*	Befestigungsschraube für Zierleiste auf Tür	screw, moulding	BN4,BN6,BN7,BT7	6
S335AH*	Zierleiste poliert Fahrgastraum hinten rechts	moulding, polished, rear cockpit RH	BN4,BT7	1
S336AH*	Zierleiste poliert Fahrgastraum hinten links	moulding, polished, rear cockpit LH	BN4,BT7	1
S337AH*	Zierleiste Fahrgastraum hinten Mitte	moulding, polished, rear cockpit center	BN4,BT7	1
S337aAH	Verbindung Zierleiste Fahrgastraum hi. Mitte	plate, joint center moulding	BN4,BT7	1
S338AH*	Zierleiste Fahrgastraum hinten	moulding, polished, rear cockpit	BN6,BN7	1
S339AH	Gewindeplatte Zierleiste hinten	plate, tapped rear moulding	BN4,BN6,BN7,BT7	A/R
S3/16"x1"sk	Senkkopfschraube 3/16"x1" UNF	screw, moulding 3/16"x1" UNF	BN4,BN6,BN7,BT7	A/R

* Die Zierleisten werden poliert und mit etwas Überlänge geliefert. Die Zierleisten sind entsprechend anzupassen.

* These mouldings are supplied polished and slightly over-length. They must be trimmed to fit your particular car.

Heck / Rear external fittings (BN4,BN6,BN7,BT7,BJ7,BJ8)

EM1AAH	Halteclip Embleme	fixing badge	BN7, BT7, BJ7, BJ8	2
EM1ATR	Halteclip Embleme	fixing badge	BN4, BN6, BN7, BT7, BJ7, BJ8	2
EM6AH	Emblem "3000"	badge "3000"	BN7, BT7, BJ7, BJ8	1
EM8AH	Emblem "Austin Healey"	badge "Austin Healey"	BN4, BN6, BN7, BT7, BJ7, BJ8	1
K13AMGB-12	Gummibuchse Aufsteller	bush, prop rod	BN4-BJ8	1
R41TR3	Haltegummi Haubenaufsteller	rubber clip, prop rod	BN4-BJ8	1
R108AH	Kofferraum Dichtgummi (geklebt)	boot seal (glued into channel)	BN4-BJ8	1
R110AH	Gummi Anschlagstopfen	buffer boot lid	BN4-BJ8	3
S211AH	Gepäckträger	luggage rack	BN4-BJ8	1
S216AH/L	Kofferraumscharnier links	boot hinge LH	BN4-BJ8	1
S216AH/R	Kofferraumscharnier rechts	boot hinge RH	BN4-BJ8	1
S218AH	Unterlage Kofferraumscharnier	gasket boot hinge	BN4-BJ8	2
S219AH	Kofferraumgriff incl. Schließzylinder	boot handle assembly with lock and 2 keys	BN4-BJ8	1
S220AH	Unterlage Kofferraumgriff	gasket, boot handle	BN4-BJ8	1
KA425AH	Fangband Kofferraumdeckel	cable, track lid control	BN4-BJ8	1
KA442AH	Haltestange Kofferraumdeckel	prop rod, track lid	BN4-BJ8	1
SR4	Rundkopfschraube 1/4" x 1" UNF	pan head screw 1/4"x1" UNF	BN4-BJ8	1

Kofferraum Montageteile / Trunk internal fittings BN4, BN6, BN7, BT7, BJ7, BJ8

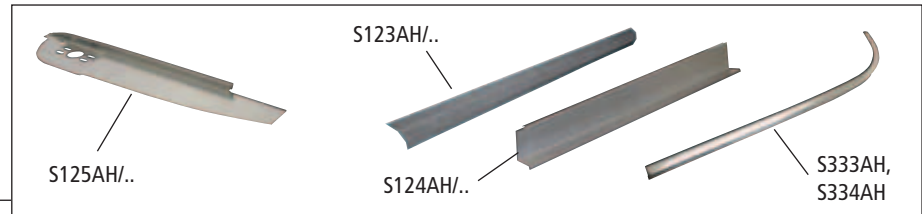
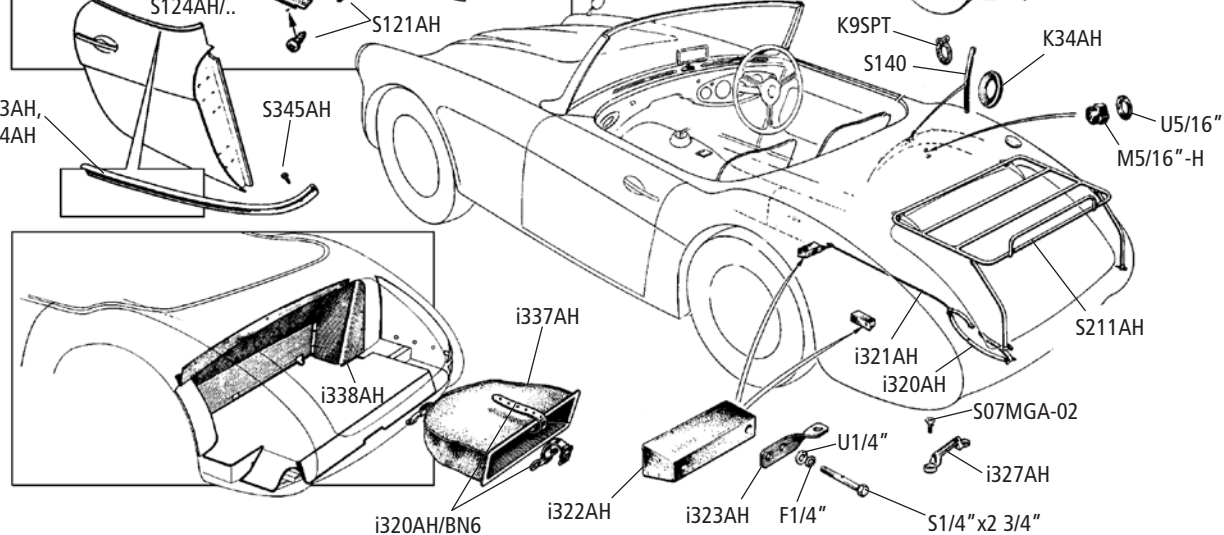
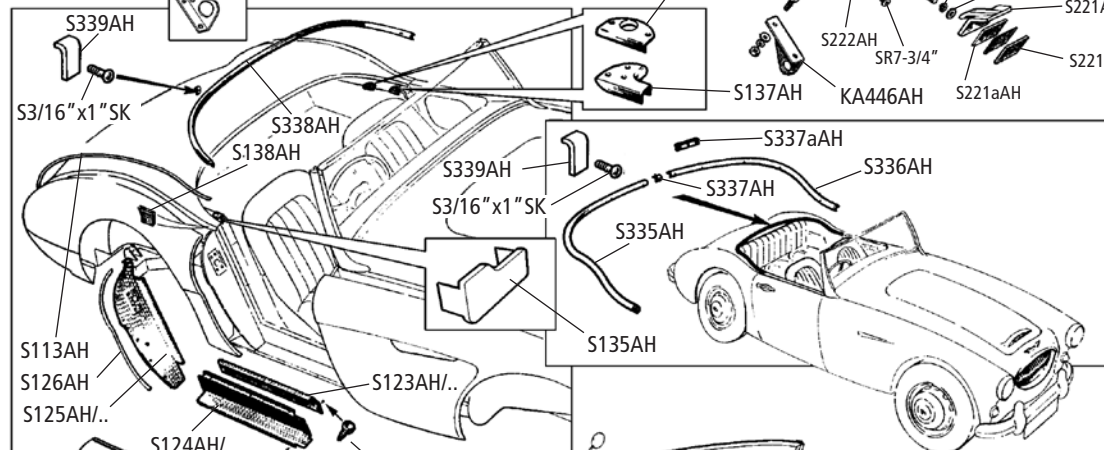
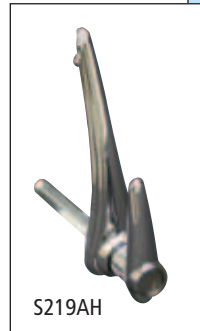
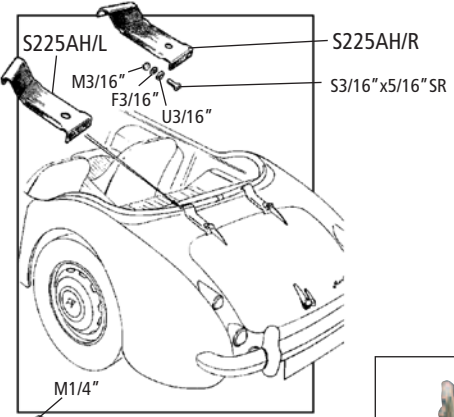
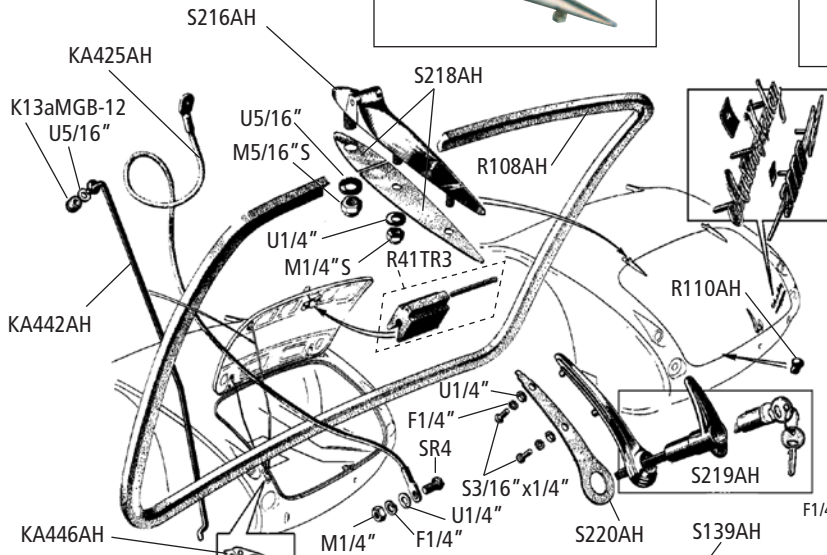
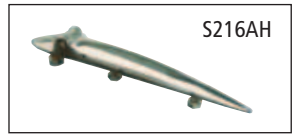

Kofferraum Montageteile / Trunk internal fittings BN4, BN6, BN7, BT7, BJ7, BJ8

No.	Bezeichnung	Description	Type	Anzahl/Qty.
Fahrgastraum / Cockpit fittings				
I337AH	Reserverad-Abdeckung	spare tire cover	BN6,BN7	1
S221AH	Falle Kofferraumschloss	striker, boot lock	BN4-BJ8	1
S221AAH	Unterlage Falle-Kofferraumschloss	packing plate, striker	BN4-BJ8	1
S221BAH	Gewindeplatte für Falle Kofferraumschloss	plate, tapped	BN4-BJ8	1
S222AH	Kofferraumschloss	boot lock	BN4-BJ8	1
S223AH	Unterlage Kofferraumschloss	packing plate	BN4-BJ8	1
S225AH/L	Versteifung links	bracket, reinforced LH	BN4, BT7	1
S225AH/R	Versteifung rechts	bracket, reinforced RH	BN4, BT7	1
I300AH/BN6	Kofferraum Ausstattungssatz	track lining kit	BN6,BN7	1
I300AH/BJ8	Kofferraum Ausstattungssatz	track lining kit	BN4,BT7,BJ7,BJ8	1
I320AH	Halteriemen Reserverad	strip securing spare wheel	BN4,BT7,BJ7,BJ8	1
I320AH/BN6	Halteriemen Reserverad	strip securing spare wheel	BN6,BN7	1
I321AH	Reserverad Haltestange	rod, retaining spare wheel	BN4,BT7,BJ7,BJ8	1
I322AH	Reserverad Halteklötz	block, spare wheel	BN4,BT7,BJ7,BJ8	2
I323AH	Halterung Reserveradbefestigung	bracket, rod retaining spare wheel	BN4,BT7,BJ7,BJ8	1
I327AH	Chrom-Verschluss Halteriemen	staple, chrome, strip retaining	BN4-BJ8	1
I338AH	Abdeckung Benzin-Einfüllrohr	panel, fuel pipe cover, black	BN4,BT7,BJ7,BJ8	1
KA446AH	Halter für Aufstellstange	bracket, stay prop rod	BN4-BJ8	1
WZ75AH	Werkzeugtasche*	tool bag*	BN4-BJ8	1
SR7-3/4"	Senkkopfschraube 1/4"x3/4" UNF	countersunk screw 1/4"x3/4" UNF	BN4-BJ8	4
S3/16"x5/16SK	Senkkopfschraube 3/16"x5/16" UNF	countersunk screw 3/16"x5/16" UNF	BN4-BT7	4
S07MGA-02	Senkkopfschraube 3/16"x5/8" UNF	countersunk screw 3/16"x5/8" UNF	BN4-BJ8	4

i300AH/BN6

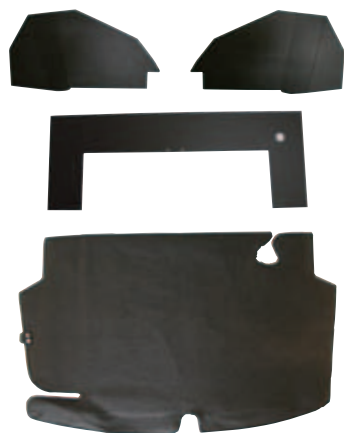

i300AH/BJ8



Weitere Teppichsätze siehe Seite 216 /
More interior trim / carpets on page 216.

Stoßstange / Bumper BN1, BN2

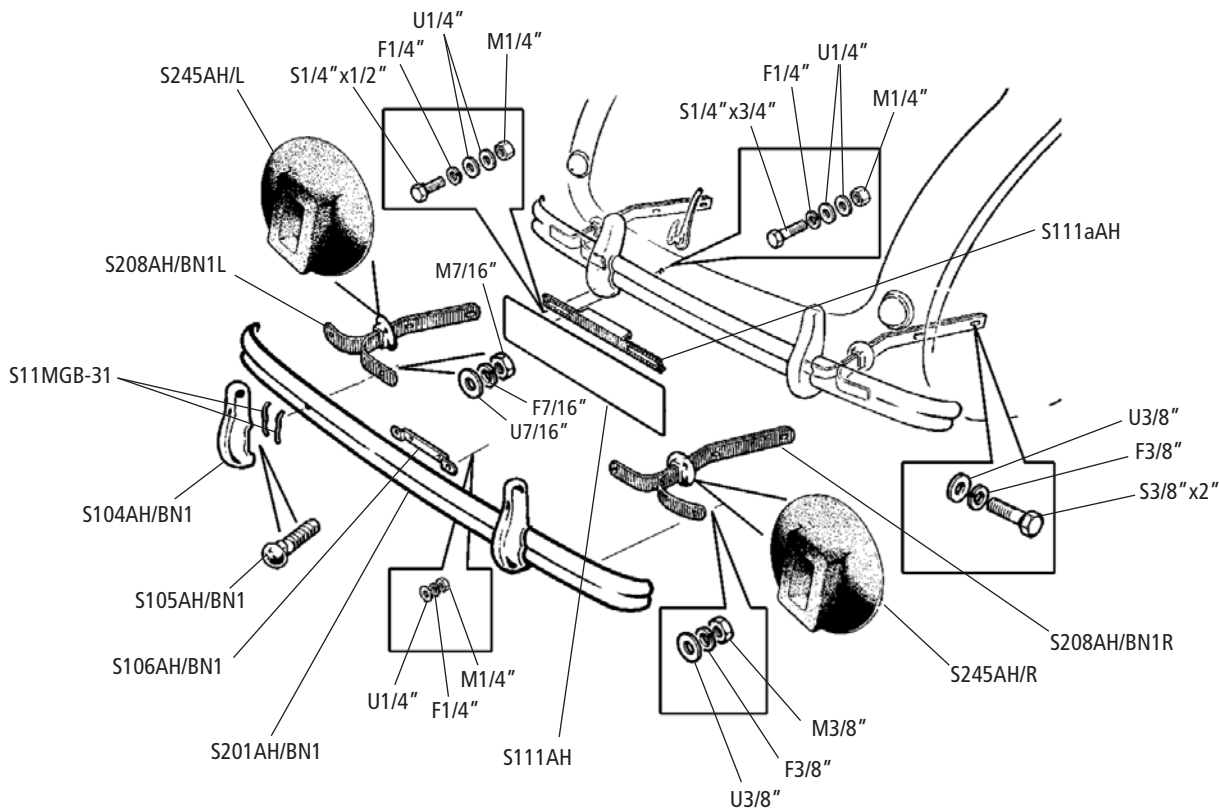
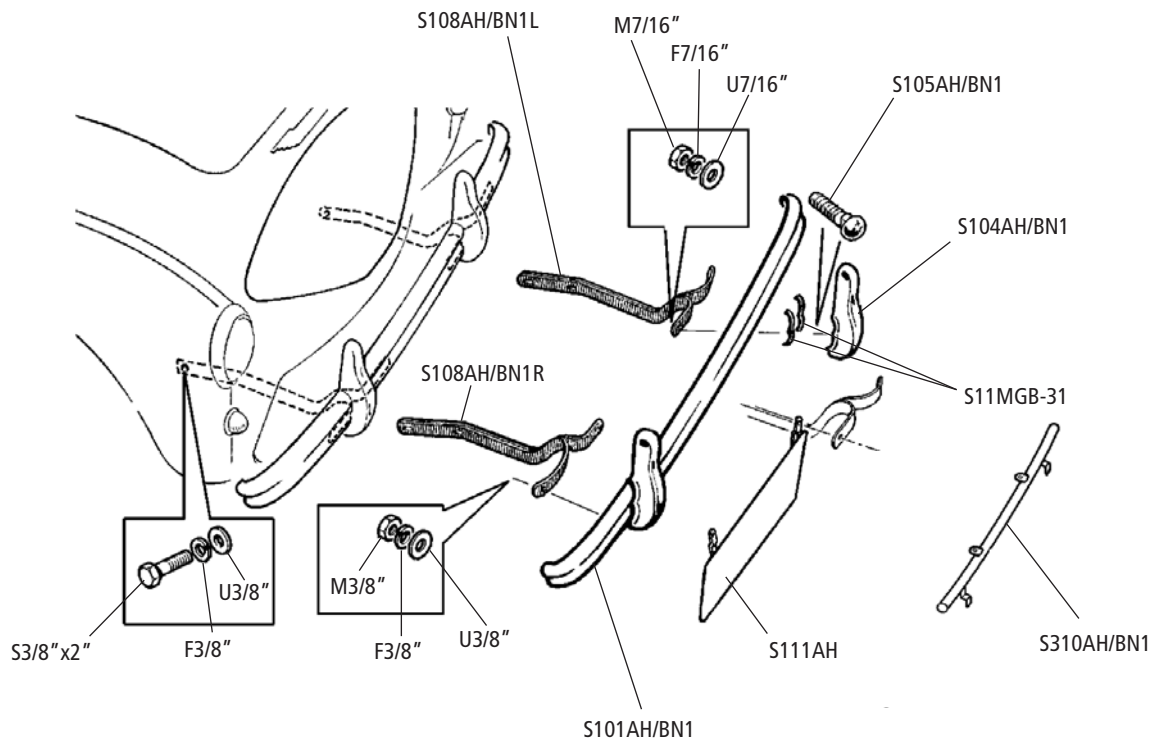

No.	Bezeichnung	Description	Type	Anzahl/Qty.
Stoßstange / Bumper BN1, BN2				
S11MGB-31	Gummidichtung Stoßstange/Horn, per Meter	packing for overriders, per meter	BN1-BN2	2
S101AH/BN1	Stoßstange vorne	bumper, front	BN1-BN2	1
S104AH/BN1	Stoßstangenhorn vorne/hinten	overrider, front/rear	BN1-BN2	2
S105AH/BN1	Schraube Stoßstangenhornbefestigung vorne/hinten	bolt, front/rear overrider mounting	BN1-BN2	2
S106AH/BN1	Halter Kennzeichenleuchte	bracket, number plate lamp	BN1-BN2	1
S108AH/BN1L	Stoßstangenhalter vorne links	bumper bracket, front LH	BN1-BN2	1
S108AH/BN1R	Stoßstangenhalter vorne rechts	bumper bracket, front RH	BN1-BN2	1
S111AH	Nummernschildträger vorne und hinten	support, front & rear number plate	BN1-BN2	1
S111aAH	Halter Nummernschildträger hinten	bracket, rear number plate	BN1-BN2	1
S201AH/BN1	Stoßstange hinten	bumper, rear	BN1-BN2	1
S208AH/BN1L	Stoßstangenhalter hinten links	bumper bracket, rear LH	BN1-BN2	1
S208AH/BN1R	Stoßstangenhalter hinten rechts	bumper bracket, rear RH	BN1-BN2	1
S245AH/L	Gummi Halter Stoßstange hinten links	grommet, spring bar, rear LH	BN1-BN2	1
S245AH/R	Gummi Halter Stoßstange hinten rechts	grommet, spring bar, rear RH	BN1-BN2	1

Abzeichenstange / Badge bar

S33dMGB-31	Halteclip für S311AH, S312AH	badge clip, to no. S311AH, S312AH	BN1-BJ8
S310AH/BN1	Abzeichenstange	badge bar	BN1-BN2
S311AH	Halteplatte für Embleme	badge plate	BN1-BJ8
S312AH	Healey Warwick Abzeichen	Healey Warwick Badge	BN1-BJ8
S313AH	Healey Warwick Abzeichen	Healey Warwick Badge	BN1-BJ8

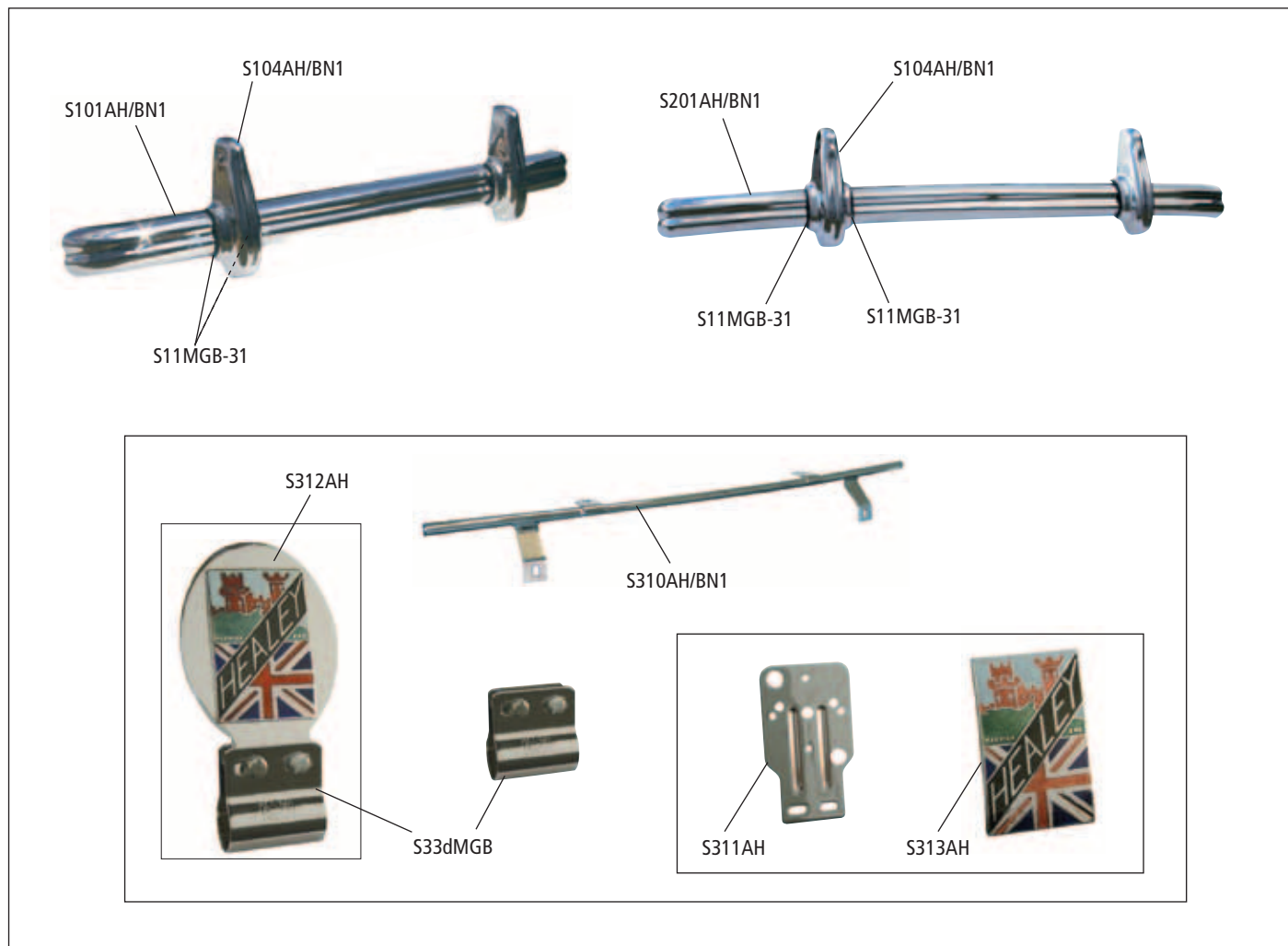

Stoßstange / Bumper BN4, BN6, BN7, BT7, BJ7, BJ8

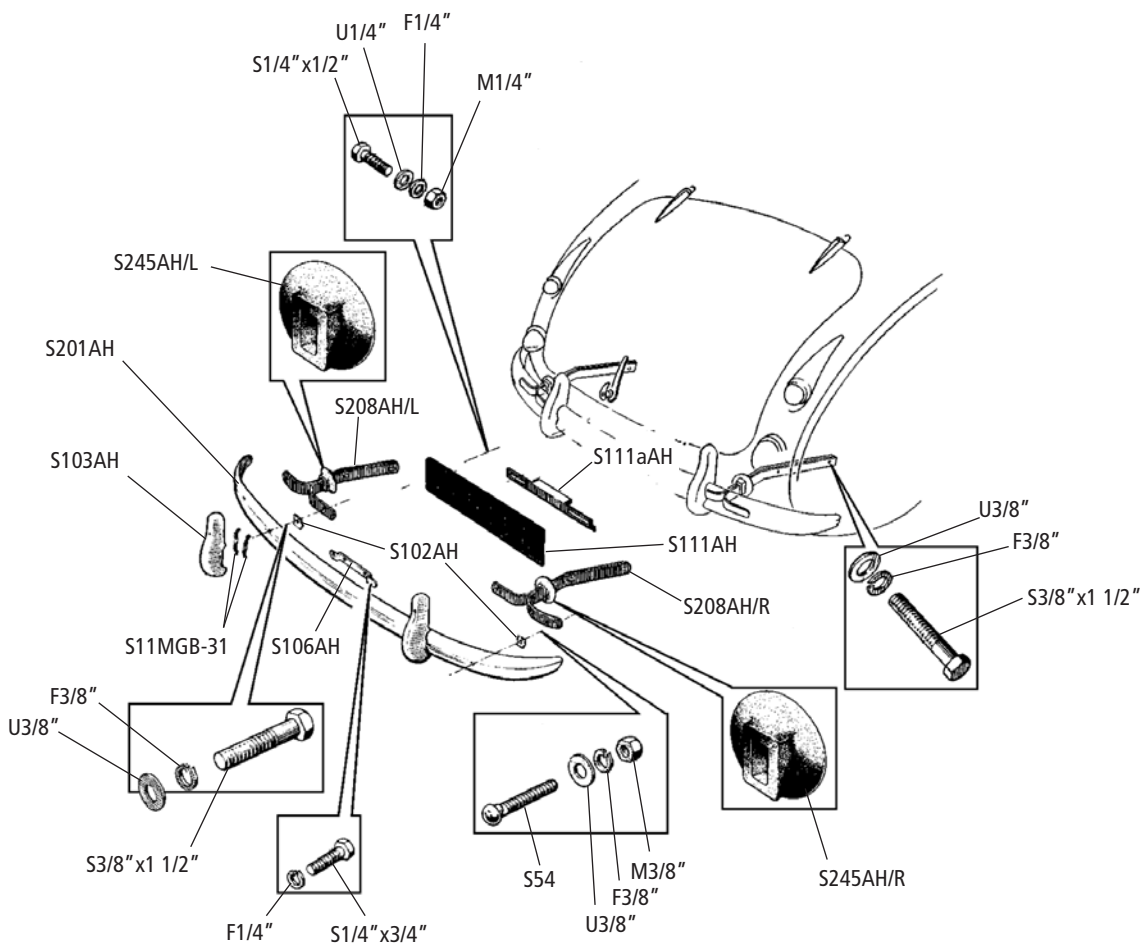
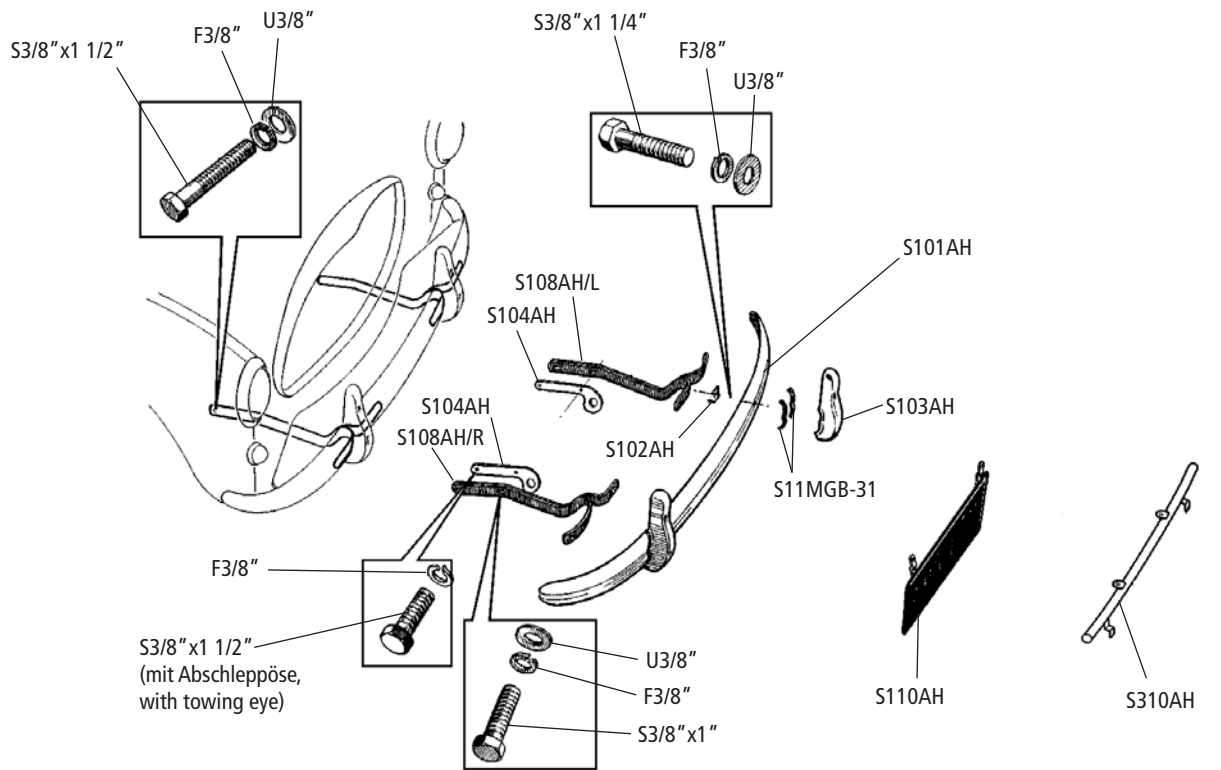

No.	Bezeichnung	Description	Type	Anzahl/Qty.
Stoßstange / Bumper BN4, BN6, BN7, BT7, BJ7, BJ8				
S11MGB-31	Gummidichtung Stoßstange/Horn per Meter	packing for overriders, per meter	BN4-BJ8	2
S101AH	Stoßstange vorne	bumper, front	BN4-BJ8	1
S102AH	Unterlage Halterung zu Stoßstange	packing, spring bar to bumper	BN4-BJ8	2
S103AH	Stoßstangenhorn vorne/hinten	overrider, front/rear	BN4-BJ8	2
S104AH	Abschleppöse	towing eye	BN4-BJ8	2
S106AH	Halter Kennzeichenleuchte	bracket, number plate lamp	BN4-BJ8	1
S108AH/L	Stoßstangenhalter vorne links	bumper bracket, front LH	BN4-BJ8	1
S108AH/R	Stoßstangenhalter vorne rechts	bumper bracket, front RH	BN4-BJ8	1
S110AH	Nummernschild Träger vorne	support, front number plate	BN4-BJ8	1
S111aAH	Halter Nummernschildträger hinten	bracket, rear number plate	BN4-BJ8	1
S111AH	Nummernschild Träger hinten	support, rear number plate	BN4-BJ8	1
S201AH	Stoßstange hinten	bumper, rear	BN4-BJ8	1
S208AH/L	Stoßstangenhalter hinten links	bumper bracket, rear LH	BN4-BJ8	1
S208AH/R	Stoßstangenhalter hinten rechts	bumper bracket, rear RH	BN4-BJ8	1
S245AH/L	Gummi Halter Stoßstange hinten links	grommet, spring bar, rear LH	BN4-BJ8	1
S245AH/R	Gummi Halter Stoßstange hinten rechts	grommet, spring bar, rear RH	BN4-BJ8	1
S3/8"X11/2"	Schraube 3/8"x1 1/2" UNF mit Abschleppöse	bolt 3/8"x1 1/2" UNF with towing eye	BN4-BJ8	4

Abzeichenstange / Badge bar

S33dMGB-31	Halteclip für S311AH, S312AH	badge clip, to no. S311AH, S312AH	BN4-BJ8
S310AH	Abzeichenstange	badge bar	BN4-BJ8
S311AH	Halteplatte für Embleme	badge plate	BN4-BJ8
S312AH	Healey Warwick Abzeichen	Healey Warwick Badge	BN4-BJ8
S313AH	Healey Warwick Abzeichen	Healey Warwick Badge	BN4-BJ8

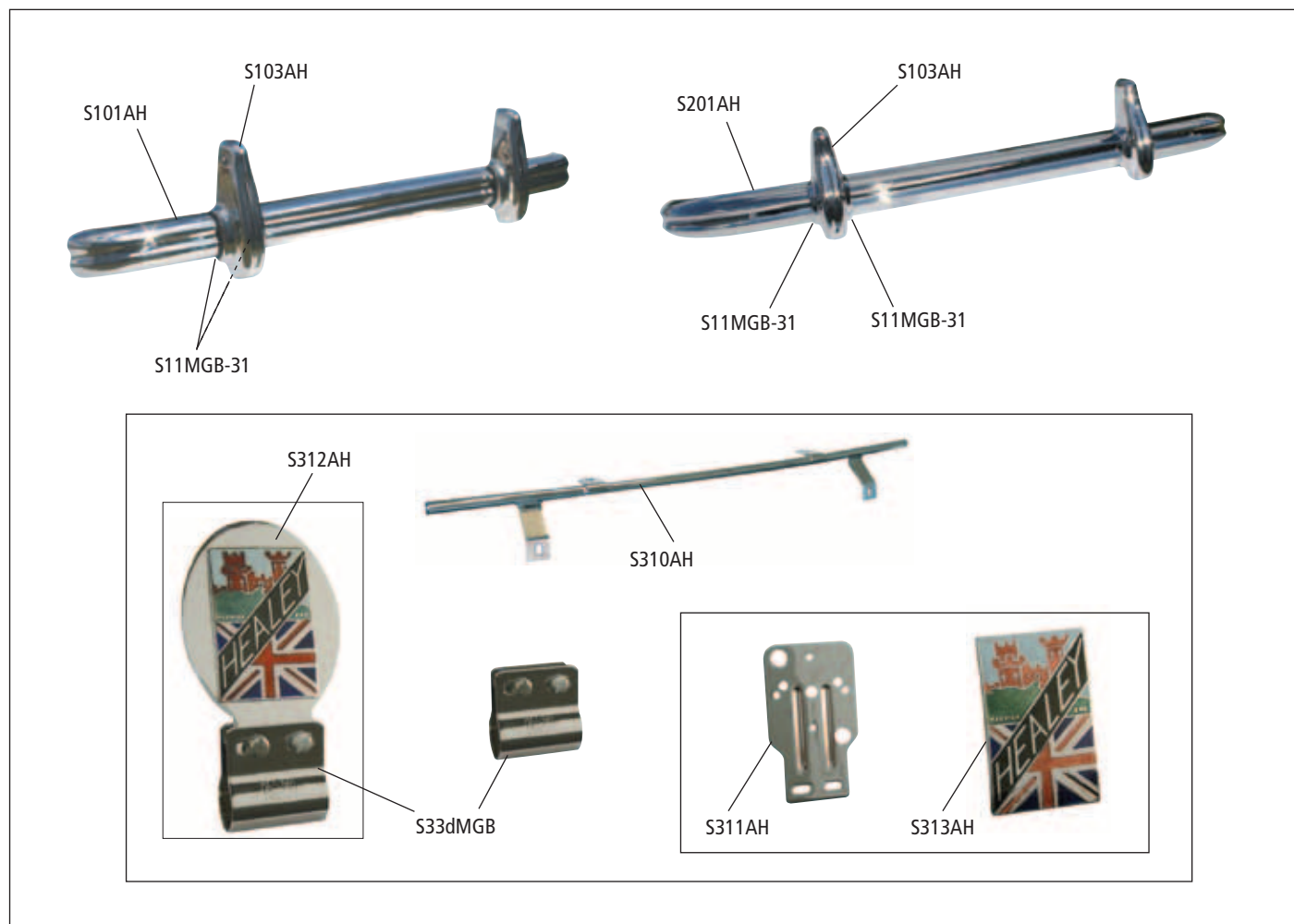

Sitzgestelle, -polster, -bezüge / Seat frames, foams and fittings BN1-BN2

i100AH/BN1..

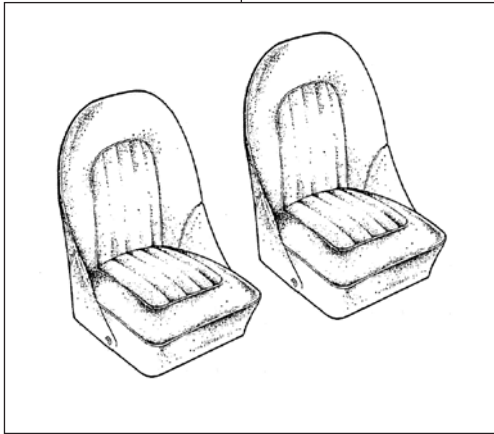

i102AH/BN1

i106AH

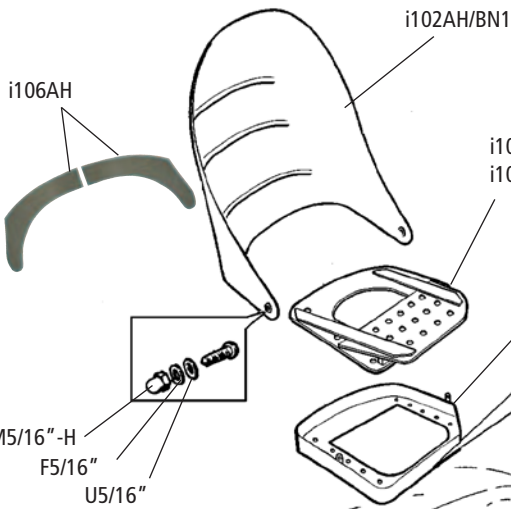

i103AH/BN1L
i103AH/BN1R

i104AH/BN1L
i104AH/BN1R



i76SPT

i113TR

i105AHL

M1/4"

F1/4"

K3/8"

F3/8"

i107AH

i105AHR

i105AH

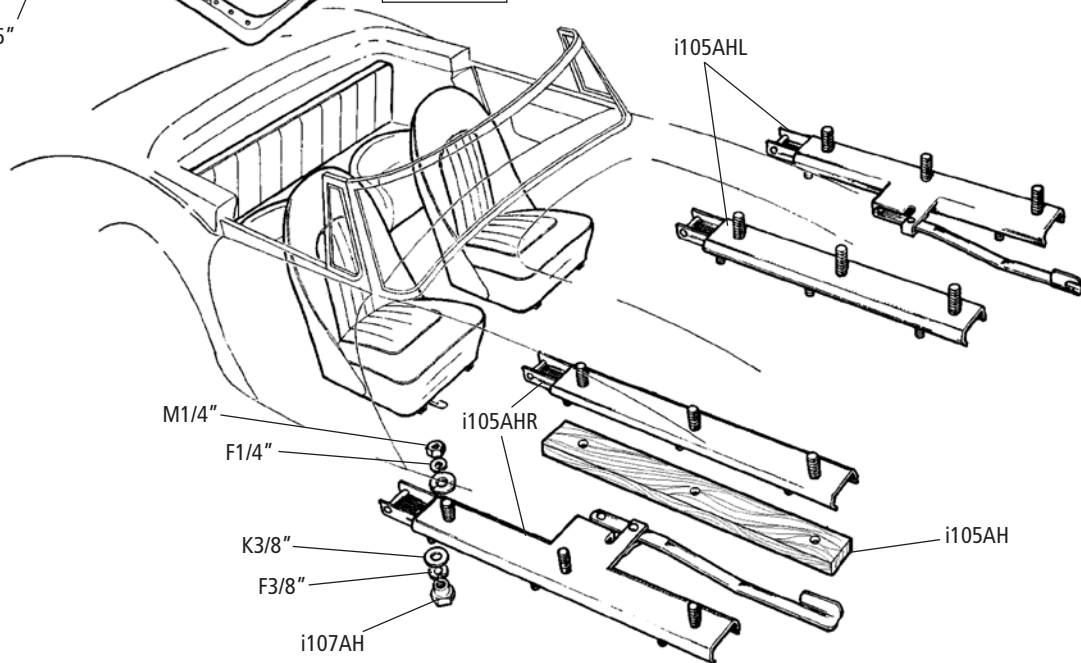

Sitzgestelle, -polster, -bezüge / Seat frames, foams and fittings BN1-BN2

No.	Bezeichnung	Description	Type	Anzahl/Qty.
i76SPT	Beckengurt universal	seat belt, static	BN1-BN2	2
i101AH	Schaumeinlage Rückenlehne	foam, seat back	BN1-BN2	2
i101AH/L	Schaumeinlage Sitz links	seat foam LH	BN1-BN2	1
i101AH/R	Schaumeinlage Sitz rechts	seat foam RH	BN1-BN2	1
i102AH/BN1	Metall-Gestell Sitzrücken	seat back, metal	BN1-BN2	2
i103AH/BN1L	Holz-Gestell Sitzschale links	seat base, wood, LH	BN1-BN2	1
i103AH/BN1R	Holz-Gestell Sitzschale rechts	seat base, wood, RH	BN1-BN2	1
i104AH/BN1L	Rahmen Sitz links	frame, seat base LH	BN1-BN2	1
i104AH/BN1R	Rahmen Sitz rechts	frame, seat base, RH	BN1-BN2	1
i105AH	Holz-Unterlage Sitzschiene	packing piece, seat slide	BN1-BN2	4
i105AH/L	Sitzschienen (2) (1 Sitz) links	seat slide set (2) (one seat), LH	BN1-BN2	1
i105AH/R	Sitzschienen (2) (1 Sitz) rechts	seat slide set (2) (one seat), RH	BN1-BN2	1
i106AH	Umrandung für Sitz	tack strip set	BN1-BN2	2
i107AH	T-Mutter für Sitzschiene	T nut	BN1-BN2	12
M5/16"-H	Chrom Hutmutter 5/16" UNF	dome nut, chrome 5/16" UNF	BN1-BN2	4
i100AH/BN1	Sitzbezüge (2) „Vinyl“ schwarz/weiss	front seat upholstery (2) „Vinyl“ black/white	BN1	1
i100AH/BN1-L	Sitzbezüge (2) „Voll Leder“ schwarz/weiss	front seat upholstery (2) „Leather“ black/white	BN1	1
i100AH/BN1-LF	Sitzbezüge (2) „Leather faced“ schwarz/weiss	front seat upholstery (2) „Leather faced“ black/white	BN1	1
i100AH/BN1-C	Sitzbezüge (2) „Vinyl“ farbig	front seat upholstery (2) „Vinyl“ coloured	BN1-BN2	1
i100AH/BN1-LC	Sitzbezüge (2) farbig „Voll Leder“	front seat upholstery (2) coloured „Leather“	BN1-BN2	1
i100AH/BN1-LFC	Sitzbezüge (2) „Leather faced“ farbig	front seat upholstery (2) „Leather faced“ coloured	BN1-BN2	1
i113TR	Halteclip Sitzbezug flach	clip, seat covering to seat frame	BN1-BN2	A/R

Hinweis:

Sitzbezüge in „Vinyl“ und „Leather faced“ sind in schwarz ab Lager lieferbar.
Sitzbezüge aus „Voll Leder“ auf Anfrage!
Farbige Sitzbezüge und Innenausstattungssteile auf Anfrage!

Note:

Seat upholstery „Vinyl“ and „Leather faced“ available from stock.
Seat upholstery „Leather“ on request!
Coloured seat upholstery and interior trim parts on request!



Sitzgestelle, -polster, -bezüge / Seat frames, foams and fittings BN4<68959

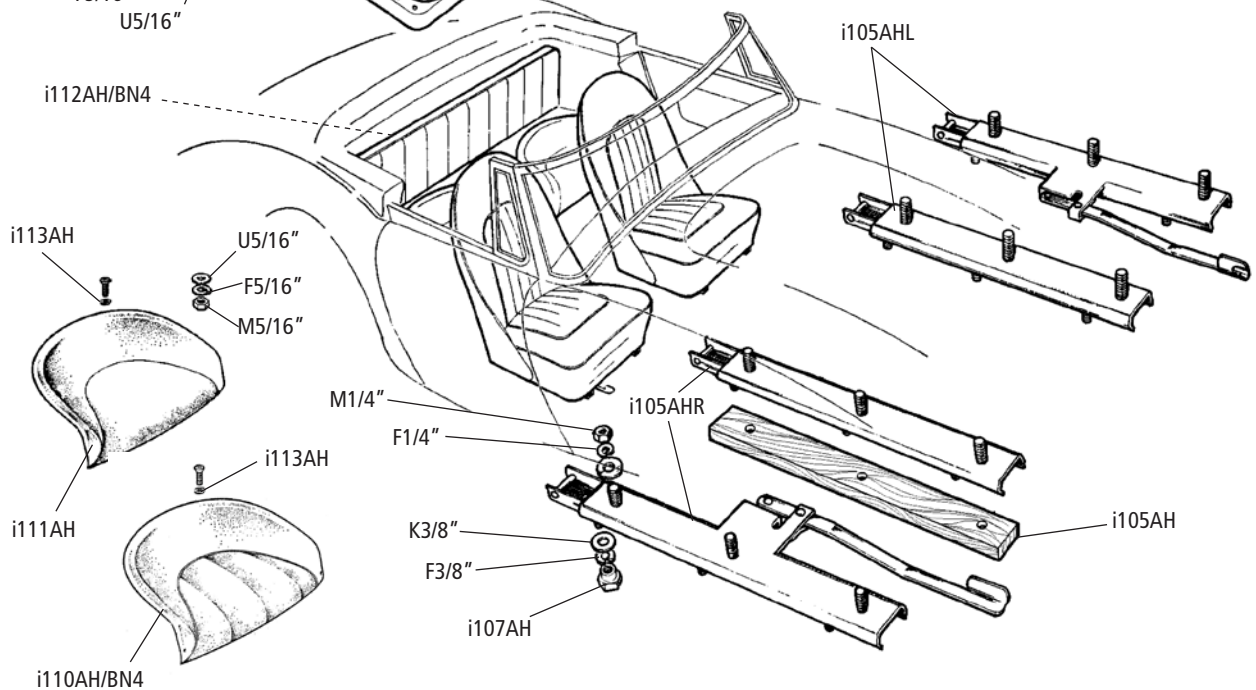
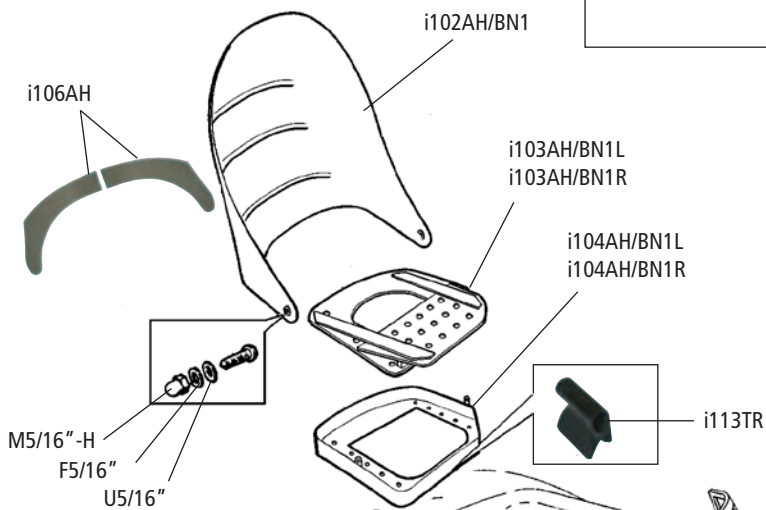
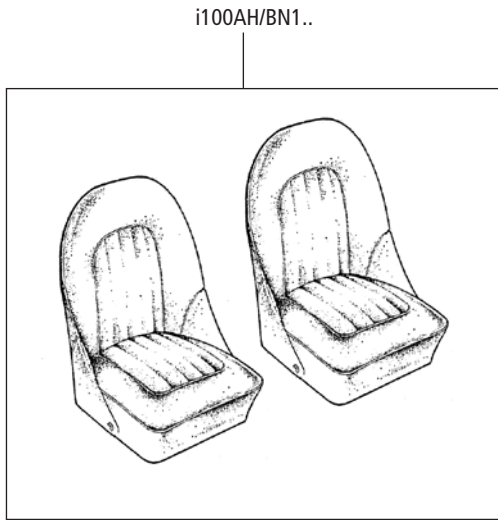

Sitzgestelle, -polster, -bezüge / Seat frames, foams and fittings BN4<68959

No.	Bezeichnung	Description	Type	Anzahl/Qty.
i76SPT	Beckengurt universal	seat belt, static	BN4<68959	2
i101AH	Schaumeinlage Rückenlehne	foam, seat back	BN4<68959	2
i101AH/L	Schaumeinlage Sitz links	seat foam LH	BN4<68959	1
i101AH/R	Schaumeinlage Sitz rechts	seat foam RH	BN4<68959	1
i102AH/BN1	Metall-Gestell Sitzrücken	seat back, metal	BN4<68959	2
i103AH/BN1L	Holz-Gestell Sitzschale links	seat base, wood, LH	BN4<68959	1
i103AH/BN1R	Holz-Gestell Sitzschale rechts	seat base, wood, RH	BN4<68959	1
i104AH/BN1L	Rahmen Sitz links	frame, seat base LH	BN4<68959	1
i104AH/BN1R	Rahmen Sitz rechts	frame, seat base, RH	BN4<68959	1
i105AH	Holz-Unterlage Sitzschiene	packing piece, seat slide	BN4<68959	4
i105AH/L	Sitzschienen (2) (1 Sitz) links	seat slide set (2) (one seat), LH	BN4<68959	1
i105AH/R	Sitzschienen (2) (1 Sitz) rechts	seat slide set (2) (one seat), RH	BN4<68959	1
i106AH	Umrandung für Sitz	tack strip set	BN4<68959	2
i107AH	T-Mutter für Sitzschiene	T nut	BN4<68959	12
i111AH	Notsitzschale	seat pan	BN4<68959	2
M5/16"-H	Chrom Hutmutter 5/16" UNF	dome nut, chrome 5/16" UNF	BN4<68959	4
i100AH/BN1	Sitzbezüge (2) „Vinyl“ schwarz/weiss	front seat upholstery (2) „Vinyl“ black/white	BN4<68959	1
i100AH/BN1-L	Sitzbezüge (2) „Voll Leder“ schwarz/weiss	front seat upholstery (2) „Leather“ black/white	BN4<68959	1
i100AH/BN1-LF	Sitzbezüge (2) „Leather faced“ schwarz/weiss	front seat upholstery (2) „Leather faced“ black/white	BN4<68959	1
i100AH/BN1-C	Sitzbezüge (2) „Vinyl“ farbig	front seat upholstery (2) „Vinyl“ coloured	BN4<68959	1
i100AH/BN1-LC	Sitzbezüge (2) farbig „Voll Leder“	front seat upholstery (2) coloured „Leather“	BN4<68959	1
i100AH/BN1-LFC	Sitzbezüge (2) „Leather faced“ farbig	front seat upholstery (2) „Leather faced“ coloured	BN4<68959	1
i110AH/BN4	Rücksitzbezug „Vinyl“ schwarz/weiss	rear seat upholstery „Vinyl“, black/white	BN4<68959	1
i110AH/BN4-L	Rücksitzbezug „Voll Leder“ schwarz/weiss	rear seat upholstery „Leather“, black/white	BN4<68959	1
i110AH/BN4-LF	Rücksitzbezug „Leather faced“ schwarz/weiss	rear seat upholstery „Leather faced“, black/white	BN4<68959	1
i110AH/BN4-C	Rücksitzbezug „Vinyl“ farbig	rear seat upholstery „Vinyl“, coloured	BN4<68959	1
i110AH/BN4-LC	Rücksitzbezug „Voll Leder“ farbig	rear seat upholstery „Leather“, coloured	BN4<68959	1
i110AH/BN4-LFC	Rücksitzbezug „Leather faced“ farbig	rear seat upholstery „Leather faced“, coloured	BN4<68959	1
i112AH/BN4	Rückwand unverkleidet	back panel, untrimmed	BN4<68959	1
i113TR	Halteclip Sitzbezug flach	clip, seat covering to seat frame	BN4<68959	A/R

Sitzbezüge, Polster und Gestelle für BN4>68960 siehe nachfolgende Seiten.

Seat framers, foams and fittings BN4>68960 on next pages.

Hinweis:

Sitzbezüge in „Vinyl“ und „Leather faced“ sind in schwarz ab Lager lieferbar.
Sitzbezüge aus „Voll Leder“ auf Anfrage!
Farbige Sitzbezüge und Innenausstattungssteile auf Anfrage!

Note:

Seat upholstery „Vinyl“ and „Leather faced“ available from stock.
Seat upholstery „Leather“ on request!
Coloured seat upholstery and interior trim parts on request!

Sitzgestelle, -polster, -bezüge / Seat frames, foams and fittings BN4>68960 + BT7

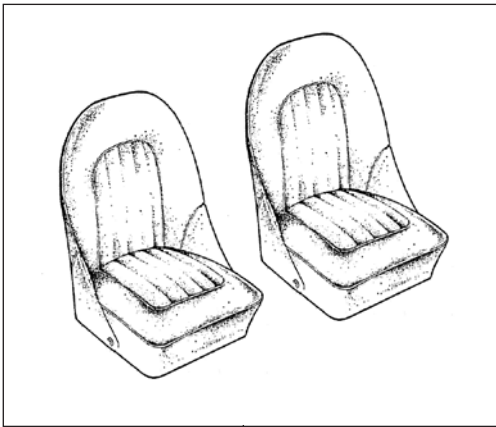

i100AH/BN4..



i111AH



i76SPT

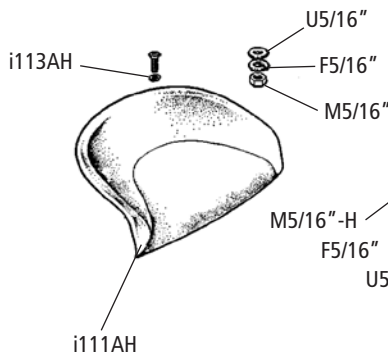

U5/16"
F5/16"
M5/16"
M5/16"-H
F5/16"
U5/16"

i113TR

i104AHL
i104AHR

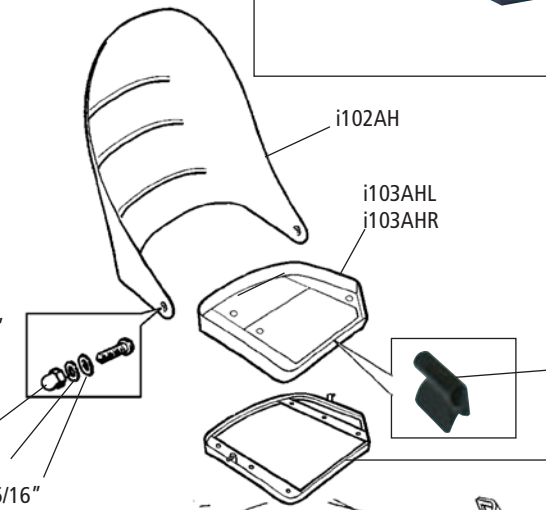

i102AH

i103AHL
i103AHR

i105AHL

i110AH/BN4

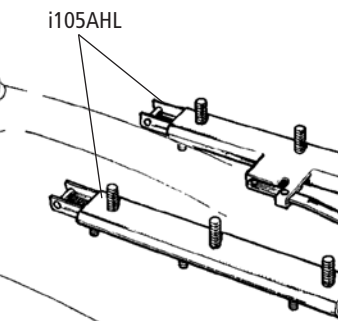

M1/4"

F1/4"

K3/8"

F3/8"

i107AH

i105AH

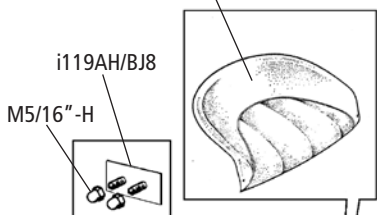

i119AH/BJ8

M5/16"-H

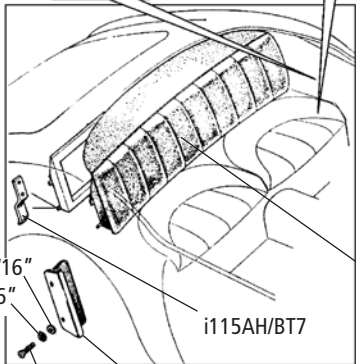

i110AH
i112AH

i115AH/BT7

S3/16"x5/8" LK

i116AH/BT7

Sitzgestelle, -polster, -bezüge / Seat frames, foams and fittings BN4>68960 + BT7

No.	Bezeichnung	Description	Type	Anzahl/Qty.
i76SPT	Beckengurt universal	seat belt, static	BN4>68960 + BT7	2
i101AH	Schaumfüllung Rückenlehne	foam, seat back	BN4>68960 + BT7	2
i101AH/L	Schaumeinlage Sitz links	seat foam LH	BN4>68960 + BT7	1
i101AH/R	Schaumeinlage Sitz rechts	seat foam RH	BN4>68960 + BT7	1
i102AH	Rückenlehne Sitz Metallteil	seat back, metal	BN4>68960 + BT7	2
i103AHL	Sitzschale links	seat base, metal, LH	BN4>68960 + BT7	1
i103AHR	Sitzschale rechts	seat base, metal, RH	BN4>68960 + BT7	1
i104AHL	Rahmen Sitz links	frame, seat base LH	BN4>68960 + BT7	1
i104AHR	Rahmen Sitz rechts	frame, seat base, RH	BN4>68960 + BT7	1
i105AH	Holz-Unterlage Sitzschiene	packing piece, seat slide	BN4>68960 + BT7	4
i105AH/L	Sitzschienen (2) (1 Sitz) links	seat slide set (2) (one seat), LH	BN4>68960 + BT7	1
i105AH/R	Sitzschienen (2) (1 Sitz) rechts	seat slide set (2) (one seat), RH	BN4>68960 + BT7	1
i107AH	T-Mutter für Sitzschiene	T nut	BN4>68960 + BT7	12
i111AH	Notsitzschale	seat pan	BN4, BT7	2
i112AH/BT7	Rückwand unverkleidet	back panel, untrimmed	BN4>68960 , BT7	1
i113AH	Conus Unterlagscheibe	washer, cup	BN4, BT7	8
i115AH/BT7	Satz Halter für Rückwand	plate & peg kit	BN4>68960 , BT7	1
i116AH/BT7	Paar Führungen Rückwand	channel, seat back retaining	BN4>68960 , BT7	2
i119AH/BJ8	Sicherheitsgurt Befestigung	seat belt mounting	BT7	2
M5/16"-H	Chrom Hutmutter 5/16" UNF	dome nut, chrome 5/16" UNF	BN4>68960 + BT7	4
S3/16"X5/8"LK	Linsenkopf-Schraube	screw	BN4>68960 + BT7	4
i100AH/BN4	Sitzbezüge (2) „Vinyl“ schwarz/weiss	front seat upholstery (2) „Vinyl“ black/white	BN4>68960 + BT7	1
i100AH/BN4-L	Sitzbezüge (2) „Voll Leder“ schwarz/weiss	front seat upholstery (2) „Leather“ black/white	BN4>68960 + BT7	1
i100AH/BN4-LF	Sitzbezüge (2) „Leather faced“ schwarz/weiss	front seat upholstery (2) „Leather faced“ black/white	BN4>68960 + BT7	1
i100AH/BN4-C	Sitzbezüge (2) „Vinyl“ farbig	front seat upholstery (2) „Vinyl“ coloured	BN4>68960 + BT7	1
i100AH/BN4-LC	Sitzbezüge (2) „Voll Leder“ farbig	front seat upholstery (2) „Leather“ coloured	BN4>68960 + BT7	1
i100AH/BN4-LFC	Sitzbezüge (2) „Leather faced“ farbig	front seat upholstery (2) „Leather faced“ coloured	BN4>68960 + BT7	1
i110AH/BN4	Rücksitzbezug „Vinyl“ schwarz/weiss	rear seat upholstery „Vinyl“, black/white	BN4>68960 + BT7	1
i110AH/BN4-L	Rücksitzbezug „Voll Leder“ schwarz/weiss	rear seat upholstery „Leather“, black/white	BN4>68960 + BT7	1
i110AH/BN4-LF	Rücksitzbezug „Leather faced“ schwarz/weiss	rear seat upholstery „Leather faced“, black/white	BN4>68960 + BT7	1
i110AH/BN4-C	Rücksitzbezug „Vinyl“ farbig	rear seat upholstery „Vinyl“, coloured	BN4>68960 + BT7	1
i110AH/BN4-LC	Rücksitzbezug „Voll Leder“ farbig	rear seat upholstery „Leather“, coloured	BN4>68960 + BT7	1
i110AH/BN4-LFC	Rücksitzbezug „Leather faced“ farbig	rear seat upholstery „Leather faced“, coloured	BN4>68960 + BT7	1
i113TR	Halteclip Sitzbezug	clip, seat covering to seat frame	BN4>68960 + BT7	A/R

Hinweis:

Sitzbezüge in „Vinyl“ und „Leather faced“ sind in schwarz ab Lager lieferbar.
Sitzbezüge aus „Voll Leder“ auf Anfrage!
Farbige Sitzbezüge und Innenausstattungssteile auf Anfrage!

Note:

Seat upholstery „Vinyl“ and „Leather faced“ available from stock.
Seat upholstery „Leather“ on request!
Coloured seat upholstery and interior trim parts on request!

Sitzgestelle, -polster, -bezüge / Seat frames, foams and fittings BN6, BN7

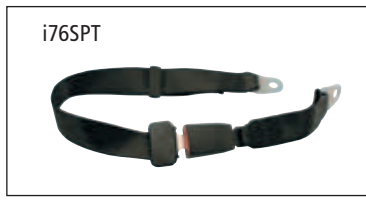
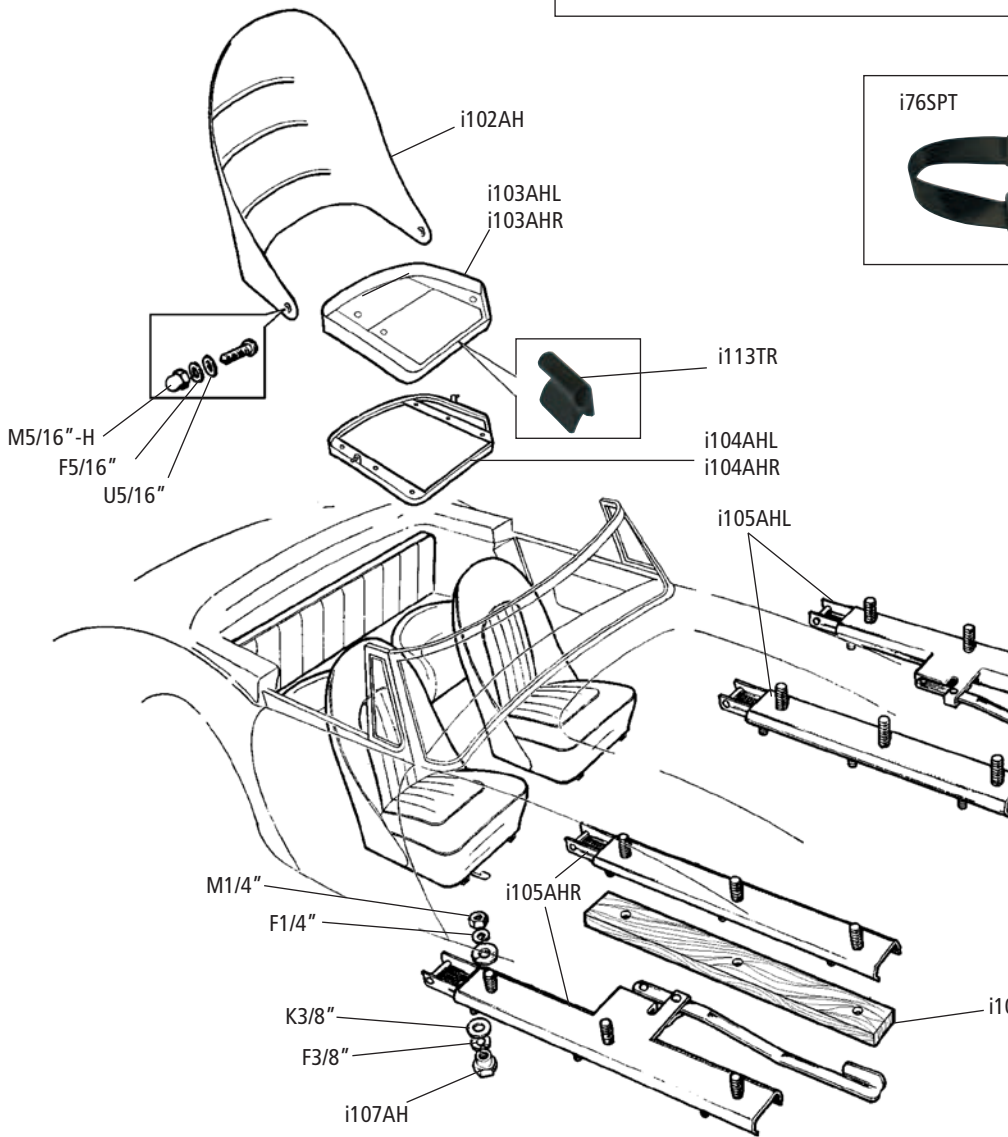
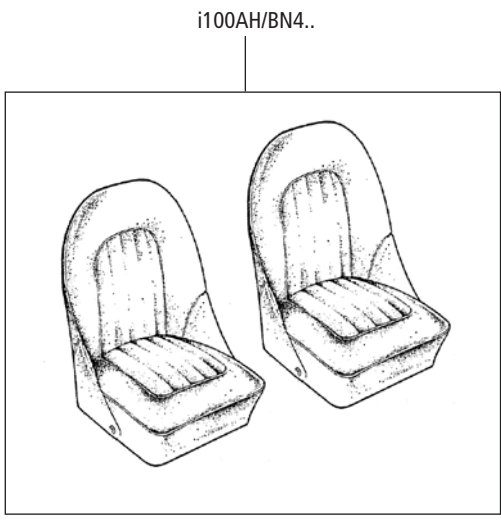

Sitzgestelle, -polster, -bezüge / Seat frames, foams and fittings BN6, BN7

No.	Bezeichnung	Description	Type	Anzahl/Qty.
i76SPT	Beckengurt universal	seat belt, static	BN6, BN7	2
i101AH	Schaumfüllung Rückenlehne	foam, seat back	BN6, BN7	2
i101AH/L	Schaumeinlage Sitz links	seat foam LH	BN6, BN7	1
i101AH/R	Schaumeinlage Sitz rechts	seat foam RH	BN6, BN7	1
i102AH	Rückenlehne Sitz Metallteil	seat back, metal	BN6, BN7	2
i103AHL	Sitzschale links	seat base, metal, LH	BN6, BN7	1
i103AHR	Sitzschale rechts	seat base, metal, RH	BN6, BN7	1
i104AHL	Rahmen Sitz links	frame, seat base LH	BN6, BN7	1
i104AHR	Rahmen Sitz rechts	frame, seat base, RH	BN6, BN7	1
i105AH	Holz-Unterlage Sitzschiene	packing piece, seat slide	BN6, BN7	4
i105AH/L	Sitzschienen (2) (1 Sitz) links	seat slide set (2) (one seat), LH	BN6, BN7	1
i105AH/R	Sitzschienen (2) (1 Sitz) rechts	seat slide set (2) (one seat), RH	BN6, BN7	1
i107AH	T-Mutter für Sitzschiene	T nut	BN6, BN7	12
M5/16"-H	Chrom Hutmutter 5/16" UNF	dome nut, chrome 5/16" UNF	BN6, BN7	4
S3/16"X5/8"LK	Linsenkopf-Schraube	screw	BN6, BN7	4
i100AH/BN4	Sitzbezüge (2) „Vinyl“ schwarz/weiss	front seat upholstery (2) „Vinyl“ black/white	BN6, BN7	1
i100AH/BN4-L	Sitzbezüge (2) „Voll Leder“ schwarz/weiss	front seat upholstery (2) „Leather“ black/white	BN6, BN7	1
i100AH/BN4-LF	Sitzbezüge (2) „Leather faced“ schwarz/weiss	front seat upholstery (2) „Leather faced“ black/white	BN6, BN7	1
i100AH/BN4-C	Sitzbezüge (2) „Vinyl“ farbig	front seat upholstery (2) „Vinyl“ coloured	BN6, BN7	1
i100AH/BN4-LC	Sitzbezüge (2) „Voll Leder“ farbig	front seat upholstery (2) „Leather“ coloured	BN6, BN7	1
i100AH/BN4-LFC	Sitzbezüge (2) „Leather faced“ farbig	front seat upholstery (2) „Leather faced“ coloured	BN6, BN7	1
i113TR	Halteclip Sitzbezug	clip, seat covering to seat frame	BN6, BN7	A/R

Hinweis:

Sitzbezüge in „Vinyl“ und „Leather faced“ sind in schwarz ab Lager lieferbar.
Sitzbezüge aus „Voll Leder“ auf Anfrage!
Farbige Sitzbezüge und Innenausstattungssteile auf Anfrage!

Note:

Seat upholstery „Vinyl“ and „Leather faced“ available from stock.
Seat upholstery „Leather“ on request!
Coloured seat upholstery and interior trim parts on request!

Sitzgestelle, -polster, -bezüge / Seat frames, foams and fittings BJ7

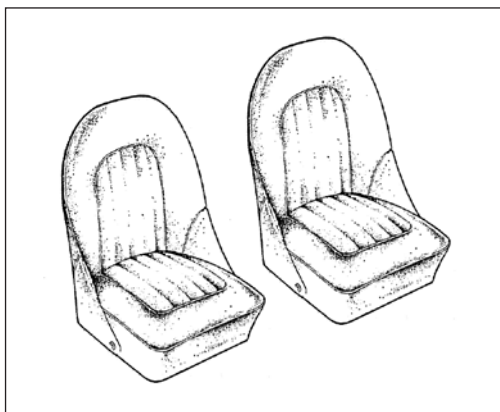

i100AH/BJ7..

i113AH

i110AH/BJ7

i113AH

U5/16"

F5/16"

M5/16"

i111AH



i111AH

i112AH/BJ7

M3/16"

i117AH/BJ7

M1/4"

F1/4"

K3/8"

F3/8"

i107AH

i105AH

i105AHL

i105AHR

S3/16"x1/2" RK

i116AH/BJ7

F3/16"

U3/16"

R41TR3

U1/4"

F1/4"

M1/4"

S3/16"x1/2" RK

U3/16"

F3/16"

M3/16"

SR4

U1/4"

F1/4"

M1/4"

R41TR3

SR4

i115AH/BJ7

i76SPT



Sitzgestelle, -polster, -bezüge / Seat frames, foams and fittings BJ7

No.	Bezeichnung	Description	Type	Anzahl/Qty.
i76SPT	Beckengurt universal	seat belt, static	BJ7	2
i101AH	Schaumfüllung Rückenlehne	foam, seat back	BJ7	2
i101AH/L	Schaumeinlage Sitz links	seat foam LH	BJ7	1
i101AH/R	Schaumeinlage Sitz rechts	seat foam RH	BJ7	1
i102AH	Rückenlehne Sitz Metallteil	seat back, metal	BJ7	2
i103AHL	Sitzschale links	seat base LH	BJ7	1
i103AHR	Sitzschale rechts	seat base RH	BJ7	1
i104AHL	Rahmen Sitz links	frame, seat base LH	BJ7	1
i104AHR	Rahmen Sitz rechts	frame, seat base, RH	BJ7	1
i105AH	Holz-Unterlage Sitzschiene	packing piece, seat slide	BJ7	4
i105AH/L	Sitzschienen (2) (1 Sitz) links	seat slide set (2) (one seat), LH	BJ7	1
i105AH/R	Sitzschienen (2) (1 Sitz) rechts	seat slide set (2) (one seat), RH	BJ7	1
i107AH	T-Mutter für Sitzschiene	T nut	BJ7	12
i113AH	Conus Unterlagscheibe	washer, cup	BJ7	8
i111AH	Notsitzschale	seat pan	BJ7	2
i112AH/BJ7	Rückwand unverkleidet	back panel, untrimmed	BJ7	1
i115AH/BJ7	Satz Halter für Rückwand	bracker, seat back	BJ7	1
i116AH/BJ7	Scharnier	hinge	BJ7	2
i327AH	Halterung verchromt	staple, breeching	BJ7	2
M5/16"-H	Chrom Hutmutter 5/16" UNF	dome nut, chrome 5/16" UNF	BJ7	4
R41TR3	Haltegummi	stop, seat back, rubber	BJ7	2
S3/16"X1/2"RK	Schraube 3/16" x 1/2"	screw 3/16" x 1/2"	BJ7	4
SR4	Rundkopfschraube	screw	BJ7	4
i100AH/BN4	Sitzbezüge (2) Vinyl schwarz/weiss	front seat upholstery (2) Vinyl black/white	BJ7	1
i100AH/BN4-L	Sitzbezüge (2) „Voll Leder“ schwarz/weiss	front seat upholstery (2) „Leather“ black/white	BJ7	1
i100AH/BN4-LF	Sitzbezüge (2) „Leather faced“ schwarz/weiss	front seat upholstery (2) „Leather faced“ black/white	BJ7	1
i100AH/BN4-C	Sitzbezüge (2) „Vinyl“ farbig	front seat upholstery (2) „Vinyl“ coloured	BJ7	1
i100AH/BN4-LC	Sitzbezüge (2) „Voll Leder“ farbig	front seat upholstery (2) „Leather“ coloured	BJ7	1
i100AH/BN4-LFC	Sitzbezüge (2) „Leather faced“ farbig	front seat upholstery (2) „Leather faced“ coloured	BJ7	1
i110AH/BJ7	Rücksitzbezug „Vinyl“ schwarz/weiss	rear seat upholstery Vinyl, black/white	BJ7	1
i110AH/BJ7-L	Rücksitzbezug „Voll Leder“ schwarz/weiss	rear seat upholstery „Leather“, black/white	BJ7	1
i110AH/BJ7-LF	Rücksitzbezug „leather faced“ schwarz/weiss	rear seat upholstery „Leather faced“, black/white	BJ7	1
i110AH/BJ7-C	Rücksitzbezug „Vinyl“ farbig	rear seat upholstery „Vinyl“, coloured	BJ7	1
i110AH/BJ7-LC	Rücksitzbezug „Voll Leder“ farbig	rear seat upholstery „Leather“, coloured	BJ7	1
i110AH/BJ7-LFC	Rücksitzbezug „Leather faced“ farbig	rear seat upholstery „Leather faced“, coloured	BJ7	1
i113TR	Halteclip Sitzbezug	clip, seat covering to seat frame	BJ7	A/R

Hinweis:

Sitzbezüge in „Vinyl“ und „Leather faced“ sind in schwarz ab Lager lieferbar.
Sitzbezüge aus „Voll Leder“ auf Anfrage!
Farbige Sitzbezüge und Innenausstattungssteile auf Anfrage!

Note:

Seat upholstery „Vinyl“ and „Leather faced“ available from stock.
Seat upholstery „Leather“ on request!
Coloured seat upholstery and interior trim parts on request!

Sitzgestelle, -polster, -bezüge / Seat frames, foams and fittings BJ8

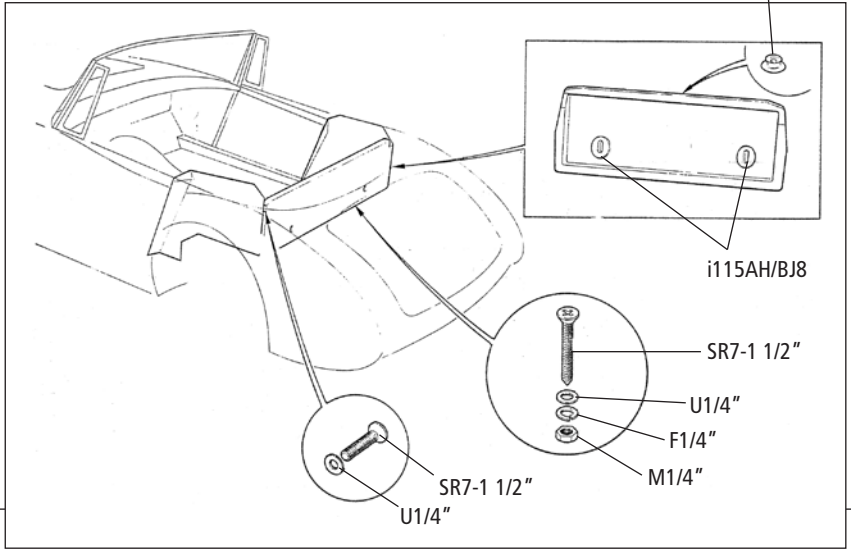
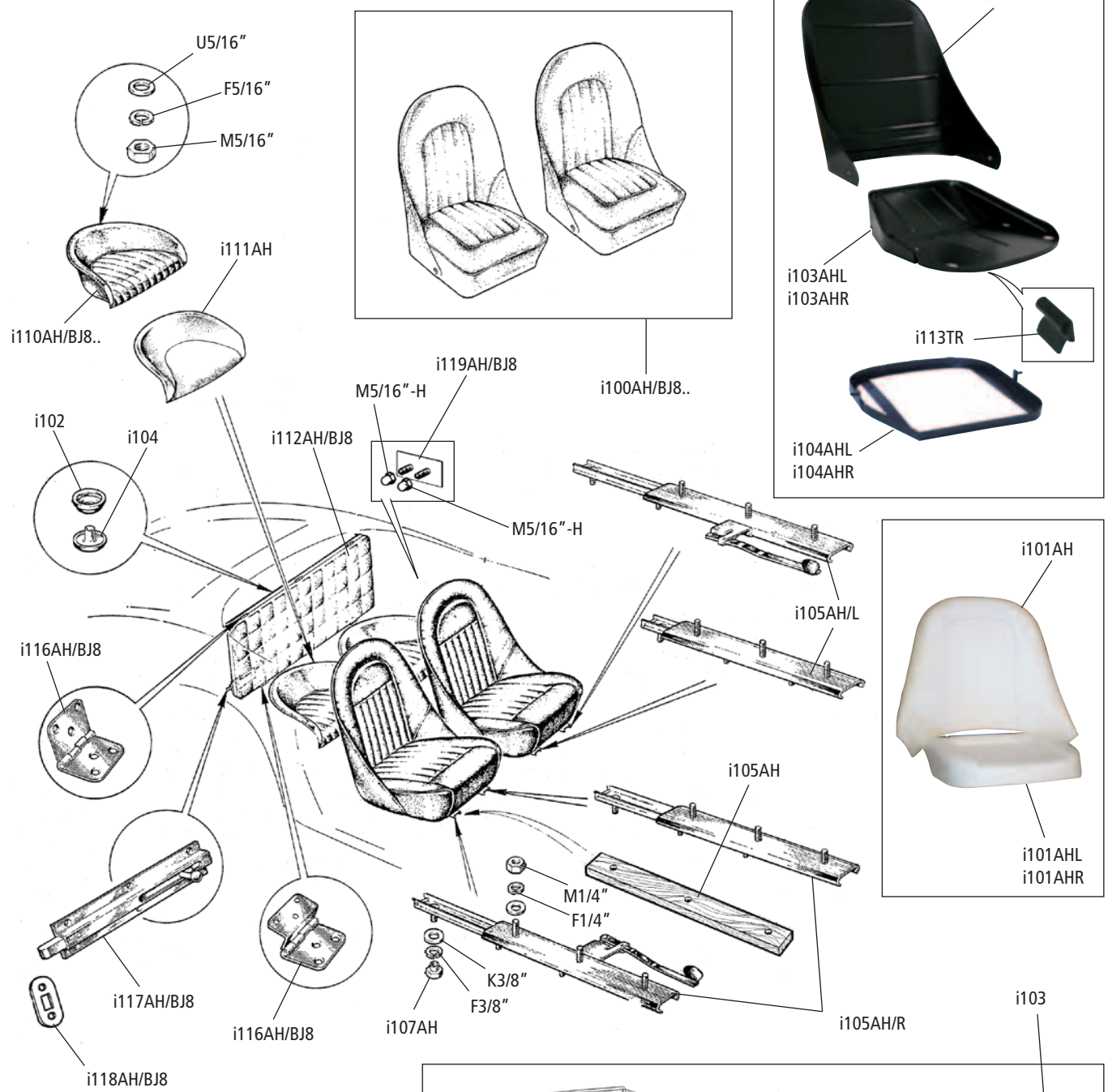

Sitzgestelle, -polster, -bezüge / Seat frames, foams and fittings BJ8

No.	Bezeichnung	Description	Type	Anzahl/Qty.
i76SPT	Beckengurt universal	seat belt, static	BJ8	2
i101AH	Schaumfüllung Rückenlehne	foam, seat back	BJ8	2
i101AH/L	Schaumeinlage Sitz links	seat foam LH	BJ8	1
i101AH/R	Schaumeinlage Sitz rechts	seat foam RH	BJ8	1
i102AH	Rückenlehne Sitz Metallteil	seat back, metal	BJ8	2
i103AHL	Sitzschale links	seat base LH	BJ8	1
i103AHR	Sitzschale rechts	seat base RH	BJ8	1
i104AHL	Rahmen Sitz links	frame, seat base LH	BJ8	1
i104AHR	Rahmen Sitz rechts	frame, seat base, RH	BJ8	1
i105AH	Holz-Unterlage Sitzschiene	packing piece, seat slide	BJ8	4
i105AH/L	Sitzschienen (2) (1 Sitz) links	seat slide set (2) (one seat), LH	BJ8	1
i105AH/R	Sitzschienen (2) (1 Sitz) rechts	seat slide set (2) (one seat), RH	BJ8	1
i107AH	T-Mutter für Sitzschiene	T nut	BJ8	12
i111AH	Notsitzschale	seat pan	BJ8	2
i112AH/BJ8	Rückwand unverkleidet	back panel, untrimmed	BJ8	1
i115AH/BJ8	Führungsplatte	plate	BJ8	2
i116AH/BJ8	Satz Scharniere Rückwand	hinge set, rear seat	BJ8	1
i117AH/BJ8	Riegel Rückwand	slide bolt	BJ8	2
i118AH/BJ8	Gegenplatte Riegel Rückwand	escutcheon, for bolt	BJ8	2
i119AH/BJ8	Sicherheitsgurt Befestigung	seat belt mounting, rear	BJ8	2
i102	Druckknopf Oberteil	washer, cup	BJ8	2
i103	Druckknopf Unterteil	snap stud	BJ8	2
i104	Druckknopf Unterteil	snap assembly, stud	BJ8	2
i113AH	Conus Unterlagscheibe	washer, cup	BJ8	8
M5/16"-H	Chrom Hutmutter 5/16" UNF	dome nut, chrome 5/16" UNF	BJ8	4
SR7-1 1/2"	Senkkopfschraube	countersunk screw	BJ8	
i100AH/BJ8	Sitzbezüge (2) Vinyl schwarz/weiß	front seat upholstery (2) Vinyl black/white	BJ8	1
i100AH/BJ8-L	Sitzbezüge (2) „Voll Leder“ schwarz/weiß	front seat upholstery (2) „Leather“ black/white	BJ8	1
i100AH/BJ8-LF	Sitzbezüge (2) „Leather faced“ schwarz / weiß	front seat upholstery (2) „Leather faced“ black/white	BJ8	1
i100AH/BJ8-C	Sitzbezüge (2) „Vinyl“ farbig	front seat upholstery (2) „Vinyl“ coloured	BJ8	1
i100AH/BJ8-LC	Sitzbezüge (2) „Voll Leder“ farbig	front seat upholstery (2) „Leather“ coloured	BJ8	1
i100AH/BJ8-LFC	Sitzbezüge (2) „Leather faced“ farbig	front seat upholstery (2) „Leather faced“ coloured	BJ8	1
i110AH/BJ8	Rücksitzbezug „Vinyl“ schwarz	rear seat upholstery Vinyl, black	BJ8	1
i110AH/BJ8-L	Rücksitzbezug „Voll Leder“ schwarz	rear seat upholstery, black „Leather“	BJ8	1
i110AH/BJ8-LF	Rücksitzbezug „Leather faced“ schwarz	rear seat upholstery, black „Leather faced“	BJ8	1
i110AH/BJ8-C	Rücksitzbezug „Vinyl“ farbig	rear seat upholstery „Vinyl“, coloured	BJ8	1
i110AH/BJ8-LC	Rücksitzbezug „Voll Leder“ farbig	rear seat upholstery „Leather“, coloured	BJ8	1
i110AH/BJ8-LFC	Rücksitzbezug „Leather faced“ farbig	rear seat upholstery „Leather faced“, coloured	BJ8	1
i113TR	Halteclip Sitzbezug	clip, seat covering to seat frame	BJ8	A/R

Hinweis:

Sitzbezüge in „Vinyl“ und „Leather faced“ sind in schwarz ab Lager lieferbar.

Sitzbezüge aus „Voll Leder“ auf Anfrage!

Farbige Sitzbezüge und Innenausstattungssteile auf Anfrage!

Note:

Seat upholstery „Vinyl“ and „Leather faced“ available from stock.

Seat upholstery „Leather“ on request!

Coloured seat upholstery and interior trim parts on request!

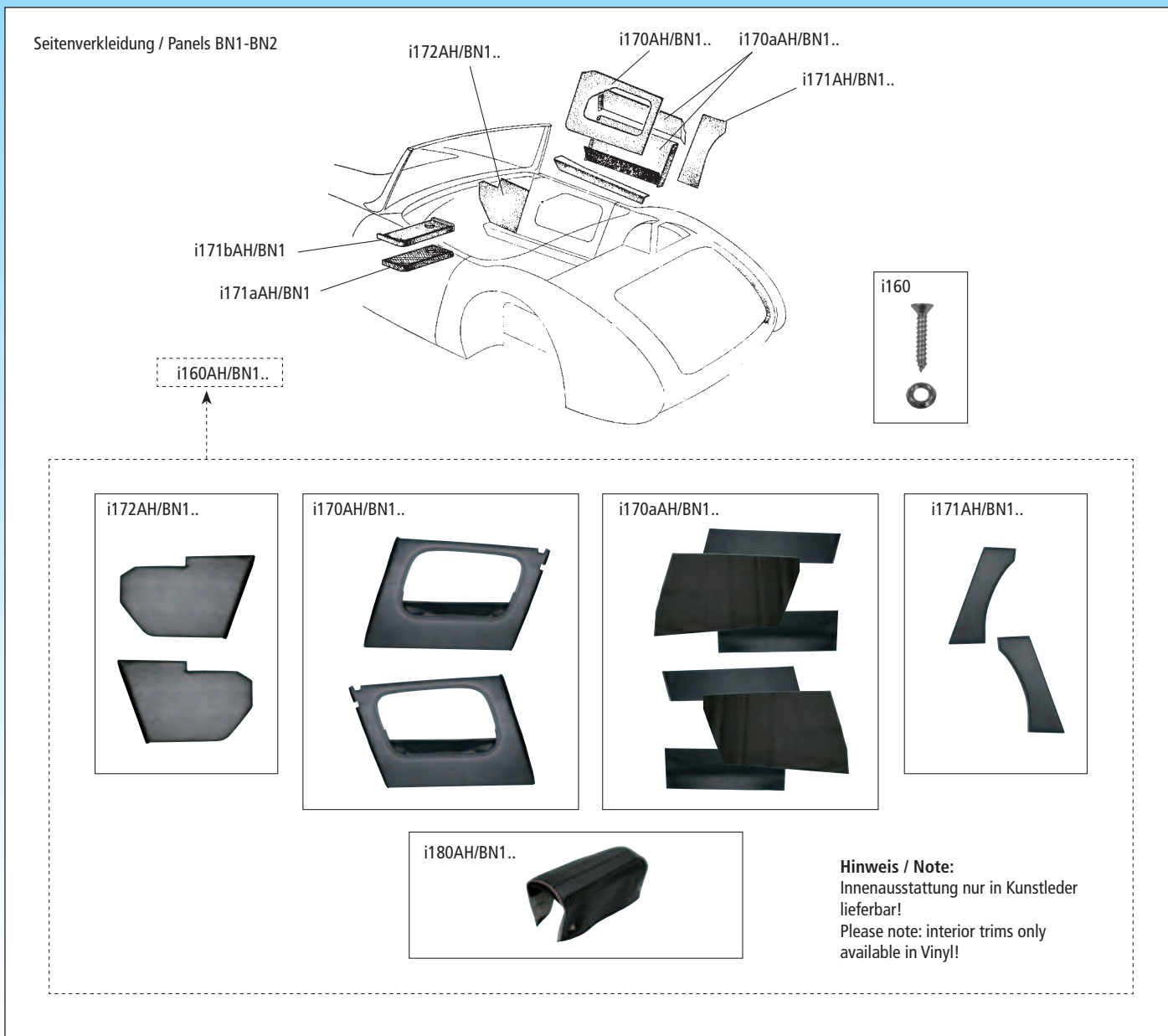

No.	Bezeichnung	Description	Type	Anzahl/Req.
i170AH/BN1	Türverkleidung Paar schwarz „Vinyl“	door panels black, pair „Vinyl“	BN1-BN2	1
i170AH/BN1-C	Türverkleidung Paar farbig „Vinyl“	door panels coloured, pair „Vinyl“	BN1-BN2	1
i170aAH/BN1	Türablage innen Paar schwarz „Vinyl“	door liners black, pair „Vinyl“	BN1-BN2	1
i170aAH/BN1-C	Türablage innen Paar farbig „Vinyl“	door liners coloured, pair „Vinyl“	BN1-BN2	1
i171AH/BN1	Seitenverkleidung hinten Paar schwarz „Vinyl“	rear quarter panels black, pair „Vinyl“	BN1-BN2	1
i171AH/BN1-C	Seitenverkleidung hinten Paar farbig „Vinyl“	rear quarter panels coloured, pair „Vinyl“	BN1-BN2	1
i171aAH/BN1	Armaturenbrett-Ablagefach unbekleidet	parcel shelf, untrimmed	BN1-BN2	1
i171bAH/BN1	Bezug Ablagefach schwarz	cover assembly, parcel shelf, black	BN1-BN2	1
i172AH/BN1	Seitenteil vorne Paar schwarz „Vinyl“	footwell panels black, pair „Vinyl“	BN1-BN2	1
i172AH/BN1-C	Seitenteil vorne Paar farbig „Vinyl“	footwell panels coloured, pair „Vinyl“	BN1-BN2	1
i180AH/BN1	Armlehne schwarz „Vinyl“	armrest black „Vinyl“	BN1-BN2	1
i180AH/BN1-C	Armlehne farbig „Vinyl“	armrest coloured „Vinyl“	BN1-BN2	1

Innenausstattungsätze / Interior trim sets

i160AH/BN1	Innenausstattungsatz schwarz „Vinyl“	interior trim set, black „Vinyl“	BN1-BN2	1
i160AH/BN1-C	Innenausstattungsatz farbig „Vinyl“	interior trim set, coloured „Vinyl“	BN1-BN2	1
i160	Schraube und Rosette	screw and rosette	BN1-BN2	20

Seitenverkleidung / Panels BN4 < 68959

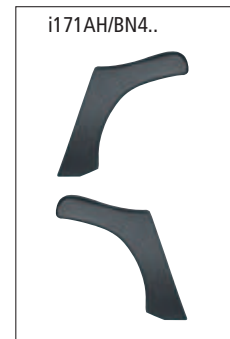
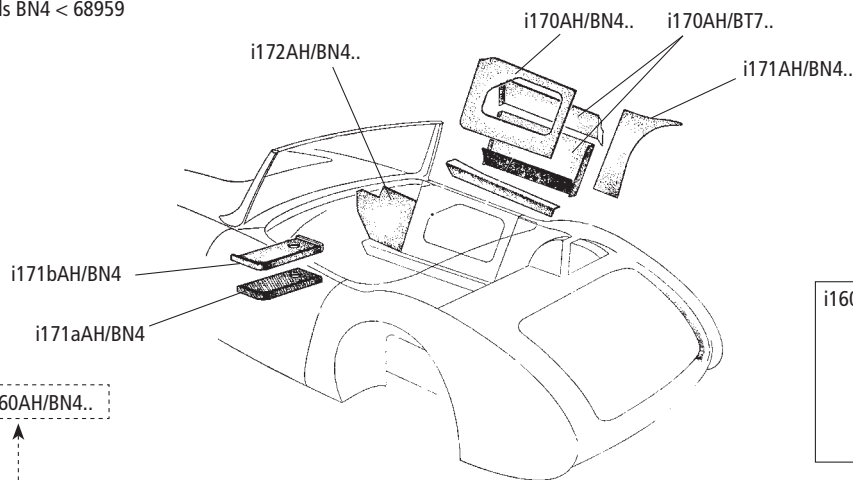

Hinweis / Note:
Innenausstattung nur in Kunstleder
lieferbar!
Please note: interior trims only
available in Vinyl!

No.	Bezeichnung	Description	Type	Anzahl/Req.
i172AH/BN4	Seitenteil vorne Paar schwarz „Vinyl“	footwell panels black, pair „Vinyl“	BN4<68959	1
i172AH/BN4-C	Seitenteil vorne Paar farbig „Vinyl“	footwell panels coloured, pair „Vinyl“	BN4<68959	1
i170AH/BN4	Türverkleidung Paar schwarz „Vinyl“	door panels black, pair „Vinyl“	BN4<68959	1
i170AH/BN4-C	Türverkleidung Paar farbig „Vinyl“	door panels coloured, pair „Vinyl“	BN4<68959	1
i170AH/BT7	Türablage Paar schwarz „Vinyl“	door liners black, pair „Vinyl“	BN4<68959	1
i170AH/BT7-C	Türablage Paar farbig „Vinyl“	door liners coloured, pair „Vinyl“	BN4<68959	1
i171AH/BN4	Seitenverkleidung hinten Paar schwarz „Vinyl“	rear quarter panels black, pair „Vinyl“	BN4<68959	1
i171AH/BN4-C	Seitenverkleidung hinten Paar farbig „Vinyl“	rear quarter panels coloured, pair „Vinyl“	BN4<68959	1
i180AH/BN1	Armlehne schwarz „Vinyl“	armrest black „Vinyl“	BN4<68959	1
i180AH/BN1-C	Armlehne farbig „Vinyl“	armrest coloured „Vinyl“	BN4<68959	1
i171aAH/BN4-L	Armaturenbrett-Ablagefach, unbekleidet LHD	parcel shelf, untrimmed, LHD	BN4<68959	1
i171aAH/BN4-R	Armaturenbrett-Ablagefach, unbekleidet RHD	parcel shelf, untrimmed, RHD	BN4<68959	1
i171bAH/BN4	Bezug Ablagefach, schwarz	cover assembly, parcel shelf, black	BN4<68959	1

Innenausstattungssätze / Interior trim sets

i160AH/BN4	Innenausstattungssatz schwarz „Vinyl“	interior trim set, black „Vinyl“	BN4<68959	1
i160AH/BN4-C	Innenausstattungssatz farbig „Vinyl“	interior trim set, coloured „Vinyl“	BN4<68959	1
i160	Schraube und Rosette	screw and rosette	BN4<68959	20

Seitenverkleidung / Panels BN4 > 68960 + BT7

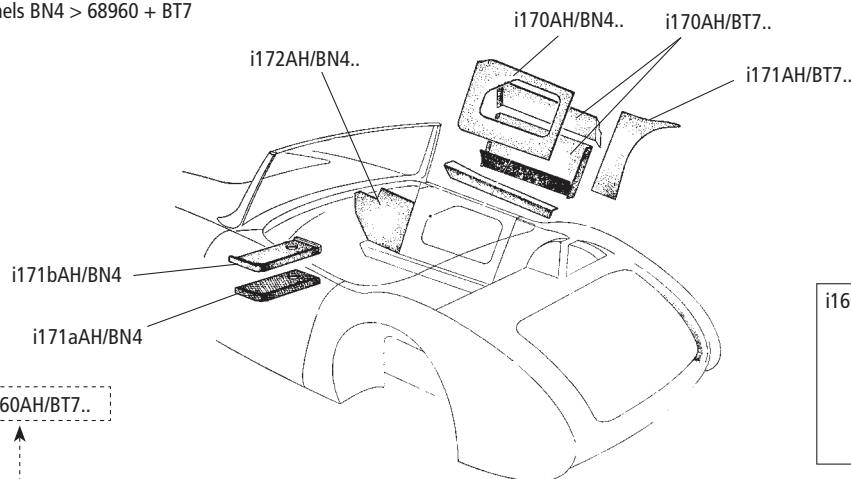

i172AH/BN4..

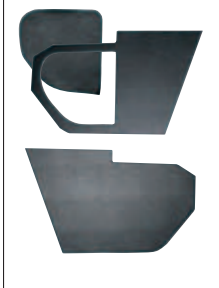

i170AH/BN4..



i170AH/BT7..



i171AH/BT7..

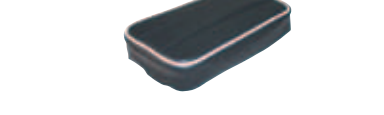

i180AH/BN4..

**Hinweis / Note:**

Innenausstattung nur in Kunstleder lieferbar!

Please note: interior trims only available in Vinyl!

No.	Bezeichnung	Description	Type	Anzahl/Req.
i172AH/BN4	Seitenteil vorne Paar schwarz „Vinyl“	footwell panels black, pair „Vinyl“	BN4>68860 + BT7	1
i172AH/BN4-C	Seitenteil vorne Paar farbig „Vinyl“	footwell panels coloured, pair „Vinyl“	BN4>68860 + BT7	1
i170AH/BN4	Türverkleidung Paar schwarz „Vinyl“	door panels black, pair „Vinyl“	BN4>68860 + BT7	1
i170AH/BN4-C	Türverkleidung Paar farbig „Vinyl“	door panels coloured, pair „Vinyl“	BN4>68860 + BT7	1
i170AH/BT7	Türablage Paar schwarz „Vinyl“	door liners black, pair „Vinyl“	BN4>68860 + BT7	1
i170AH/BT7-C	Türablage Paar farbig „Vinyl“	door liners coloured, pair „Vinyl“	BN4>68860 + BT7	1
i171AH/BT7	Seitenverkleidung hinten Paar schwarz „Vinyl“	rear quarter panels black, pair „Vinyl“	BN4>68860 + BT7	1
i171AH/BT7-C	Seitenverkleidung hinten Paar farbig „Vinyl“	rear quarter panels coloured, pair „Vinyl“	BN4>68860 + BT7	1
i180AH/BN4	Armlehne schwarz „Vinyl“	armrest black „Vinyl“	BN4>68860 + BT7	1
i180AH/BN4-C	Armlehne farbig „Vinyl“	armrest coloured „Vinyl“	BN4>68860 + BT7	1
i171aAH/BN4-L	Armaturen Brett-Ablagefach, unbekleidet, LHD	parcel shelf, untrimmed, LHD	BN4>68860 + BT7	1
i171aAH/BN4-R	Armaturen Brett-Ablagefach, unbekleidet, RHD	parcel shelf, untrimmed, RHD	BN4>68860 + BT7	1
i171bAH/BN4	Bezug Ablagefach, schwarz	cover assembly, parcel shelf, black	BN4>68860 + BT7	1

Innenausstattungsätze / Interior trim sets

i160AH/BT7	Innenausstattungsatz schwarz „Vinyl“	interior trim set, black „Vinyl“	BN4>68860 + BT7	1
i160AH/BT7-C	Innenausstattungsatz farbig „Vinyl“	interior trim set, coloured „Vinyl“	BN4>68860 + BT7	1
i160	Schraube und Rosette	screw and rosette	BN4>68860 + BT7	20

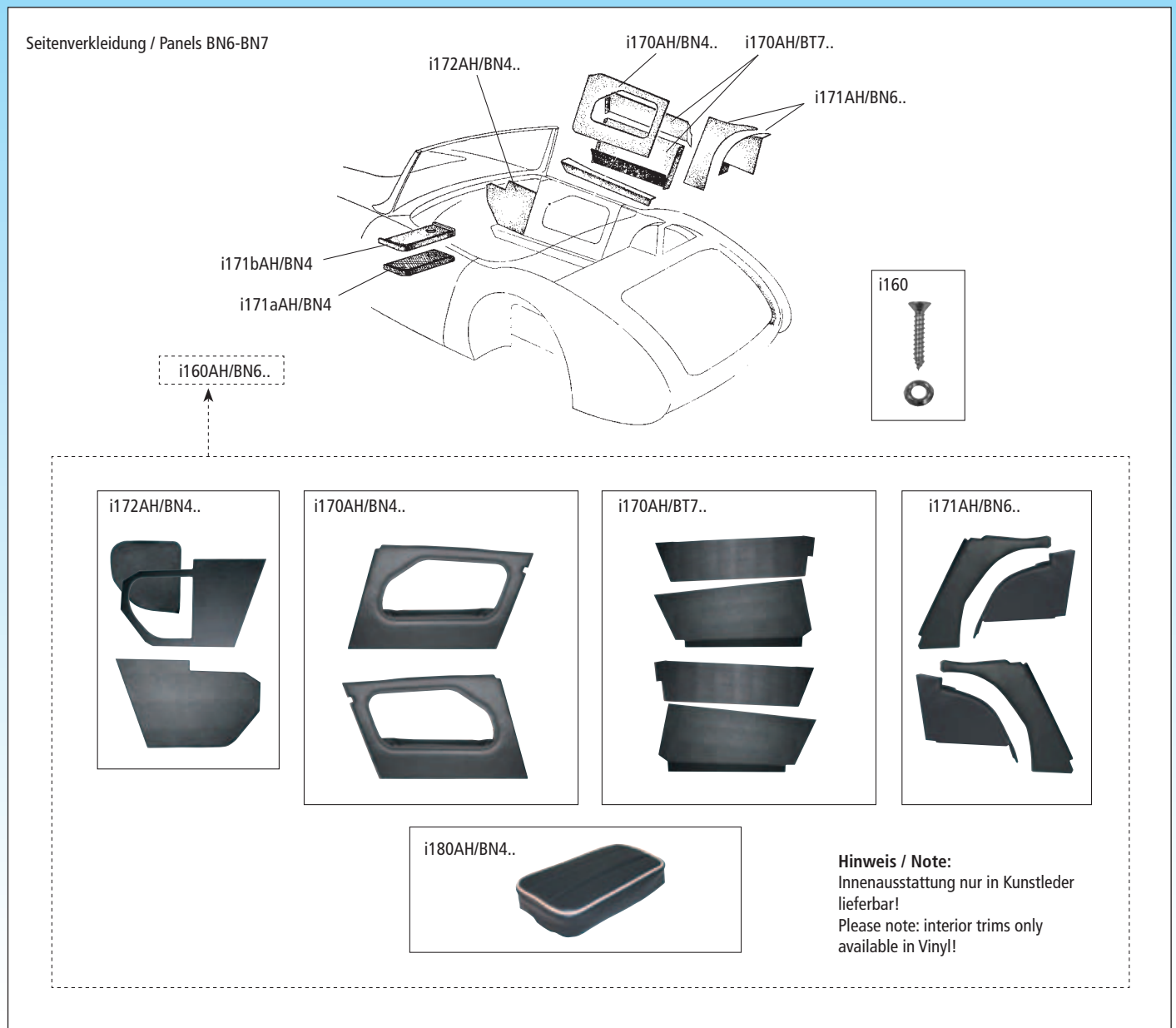

No.	Bezeichnung	Description	Type	Anzahl/Req.
i172AH/BN4	Seitenteil vorne Paar schwarz „Vinyl“	footwell panels black, pair „Vinyl“	BN6-BN7	1
i172AH/BN4-C	Seitenteil vorne Paar farbig „Vinyl“	footwell panels coloured, pair „Vinyl“	BN6-BN7	1
i170AH/BN4	Türverkleidung Paar schwarz „Vinyl“	door panels black, pair „Vinyl“	BN6-BN7	1
i170AH/BN4-C	Türverkleidung Paar farbig „Vinyl“	door panels coloured, pair „Vinyl“	BN6-BN7	1
i170AH/BT7	Türablage Paar schwarz „Vinyl“	door liners black, pair „Vinyl“	BN6-BN7	1
i170AH/BT7-C	Türablage Paar farbig „Vinyl“	door liners coloured, pair „Vinyl“	BN6-BN7	1
i171AH/BN6	Seitenverkleidung hinten Paar schwarz „Vinyl“	rear quarter panels black, pair „Vinyl“	BN6-BN7	1
i171AH/BN6-C	Seitenverkleidung hinten Paar farbig „Vinyl“	rear quarter panels coloured, pair „Vinyl“	BN6-BN7	1
i180AH/BN4	Armlehne schwarz „Vinyl“	armrest black „Vinyl“	BN6-BN7	1
i180AH/BN4-C	Armlehne farbig „Vinyl“	armrest coloured „Vinyl“	BN6-BN7	1
i171aAH/BN4-L	Armaturenbrett-Ablagefach, unbekleidet, LHD	parcel shelf, untrimmed, LHD	BN6-BN7	1
i171aAH/BN4-R	Armaturenbrett-Ablagefach, unbekleidet, RHD	parcel shelf, untrimmed, RHD	BN6-BN7	1
i171bAH/BN4	Bezug Ablagefach, schwarz	cover assembly, parcel shelf, black	BN6-BN7	1

Innenausstattungsätze / Interior trim sets

i160AH/BN6	Innenausstattungsatz schwarz „Vinyl“	interior trim set, black „Vinyl“	BN6-BN7	1
i160AH/BN6-C	Innenausstattungsatz farbig „Vinyl“	interior trim set, coloured „Vinyl“	BN6-BN7	1
i160	Schraube und Rosette	screw and rosette	BN6-BN7	20

Seitenverkleidung / Panels BJ7

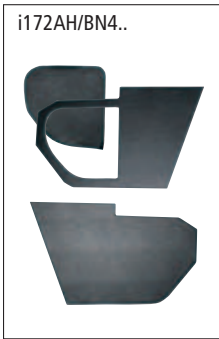
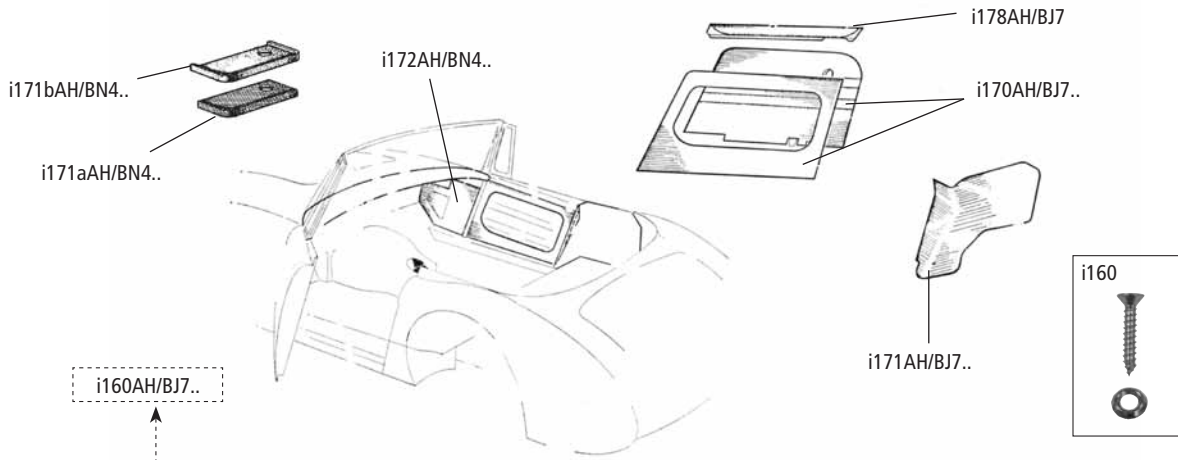

Hinweis / Note:
 Innenausstattung nur in Kunstleder
 lieferbar!
 Please note: interior trims only
 available in Vinyl!

No.	Bezeichnung	Description	Type	Anzahl/Req.
i172AH/BN4	Seitenteil vorne Paar schwarz „Vinyl“	footwell panels black, pair „Vinyl“	BJ7	1
i172AH/BN4-C	Seitenteil vorne Paar farbig „Vinyl“	footwell panels coloured, pair „Vinyl“	BJ7	1
i170AH/BJ7	Türverkleidung Paar schwarz „Vinyl“	door panels black, pair „Vinyl“	BJ7	1
i170AH/BJ7-C	Türverkleidung Paar farbig „Vinyl“	door panels coloured, pair „Vinyl“	BJ7	1
i171AH/BJ7	Seitenverkleidung hinten Paar schwarz „Vinyl“	door liners black, pair „Vinyl“	BJ7	1
i171AH/BJ7-C	Seitenverkleidung hinten Paar farbig „Vinyl“	door liners coloured, pair „Vinyl“	BJ7	1
i180AH/BN4	Armlehne schwarz/weiß „Vinyl“	armrest black „Vinyl“	BJ7	1
i180AH/BN4-C	Armlehne farbig „Vinyl“	armrest coloured „Vinyl“	BJ7	1
i171aAH/BN4-L	Armaturenblett-Ablage LHD unlackiert	parcel shelf, untrimmed, LHD	BJ7	1
i171aAH/BN4-R	Armaturenblett-Ablage RHD unlackiert	parcel shelf, untrimmed, RHD	BJ7	1
i171bAH/BN4	Bezug Ablagefach schwarz	cover assembly, parcel shelf, black	BJ7	1
i178AHBJ7	Türauflagen Paar schwarz	door capping coloured, pair	BJ7	1

Innenausstattungsätze / Interior trim sets

i160AH/BJ7	Innenausstattungsatz schwarz „Vinyl“	interior trim set, black „Vinyl“	BJ7	1
i160AH/BJ7-C	Innenausstattungsatz farbig „Vinyl“	interior trim set, coloured „Vinyl“	BJ7	1
i160	Schraube und Rosette	screw and rosette	BJ7	20

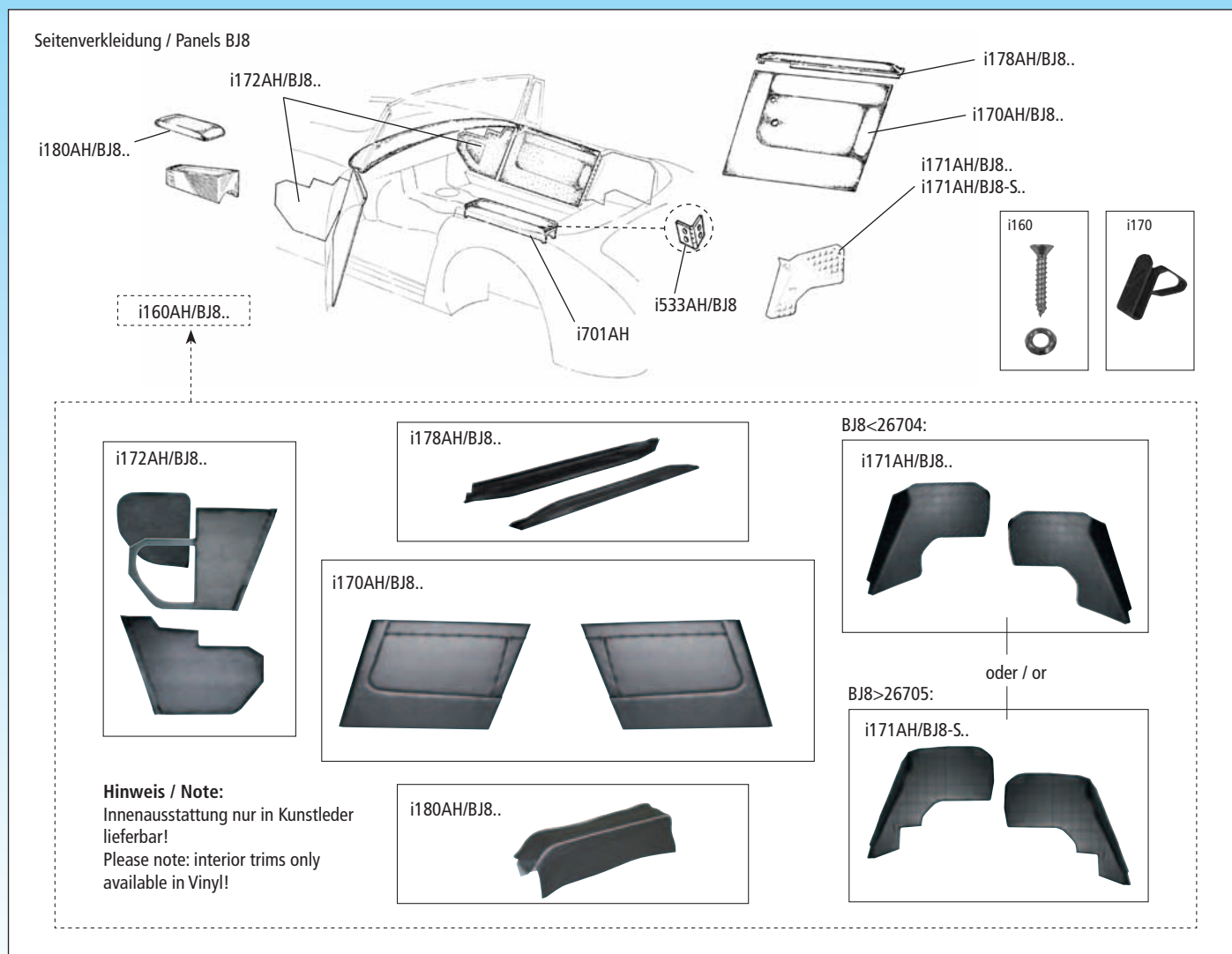

No.	Bezeichnung	Description	Type	Anzahl/Req.
i172AH/BJ8	Seitenteil vorne Paar schwarz „Vinyl“	footwell panels black, pair „Vinyl“	BJ8	1
i172AH/BJ8-C	Seitenteil vorne Paar farbig „Vinyl“	footwell panels coloured, pair „Vinyl“	BJ8	1
i170AH/BJ8	Türverkleidung Paar schwarz „Vinyl“	door panels black, pair „Vinyl“	BJ8	1
i170AH/BJ8-C	Türverkleidung Paar farbig „Vinyl“	door panels coloured, pair „Vinyl“	BJ8	1
i171AH/BJ8	Seitenverkleidung hinten Paar schwarz „Vinyl“	rear quarter panels black, pair „Vinyl“	BJ8<26704	1
i171AH/BJ8-C	Seitenverkleidung hinten Paar farbig „Vinyl“	rear quarter panels coloured, pair „Vinyl“	BJ8<26704	1
i171AH/BJ8-S	Seitenverkleidung hinten Paar schwarz „Vinyl“	rear quarter panels black, pair „Vinyl“	BJ8>26705	1
i171AH/BJ8-SC	Seitenverkleidung hinten Paar farbig „Vinyl“	rear quarter panels coloured, pair „Vinyl“	BJ8>26705	1
i180AH/BJ8	Armlehnenbezug schwarz „Vinyl“	armrest cover black „Vinyl“	BJ8	1
i180AH/BJ8-C	Armlehnenbezug farbig „Vinyl“	armrest cover coloured „Vinyl“	BJ8	1
i180AH/BJ8-L	Armlehnenbezug schwarz „Leder“	armrest cover black „Leather“	BJ8	1
i180AH/BJ8-LC	Armlehnenbezug farbig „Leder“	armrest cover coloured „Leathet“	BJ8	1
i533AH/BJ8	Scharnier Armlehne	hinge, armrest	BJ8<26705	2
i701AH	Armlehne unverkleidet, spät, feststehend	armrest, fixed, untrimmed, late model	BJ8>26704	1
i178AHBJ8	Türauflagen Paar schwarz	door capping black, pair	BJ8	1
i178AHBJ8-C	Türauflagen Paar farbig	door capping coloured, pair	BJ8	1
Innenausstattungsätze / Interior trim sets				
i160AH/BJ8	Innenausstattungsatz schwarz „Vinyl“	interior trim set, black „Vinyl“	BJ8<26704	1
i160AH/BJ8-C	Innenausstattungsatz farbig „Vinyl“	interior trim set, coloured „Vinyl“	BJ8<26704	1
i160AH/BJ8-S	Innenausstattungsatz schwarz „Vinyl“	interior trim set, black „Vinyl“	BJ8>26705	1
i160AH/BJ8-SC	Innenausstattungsatz farbig „Vinyl“	interior trim set, coloured „Vinyl“	BJ8>26705	1
i160	Schrauben + Rosetten	screw and rosette	BJ8	20
i170	Klammer Türverkleidung	clip, door panel	BJ8	20

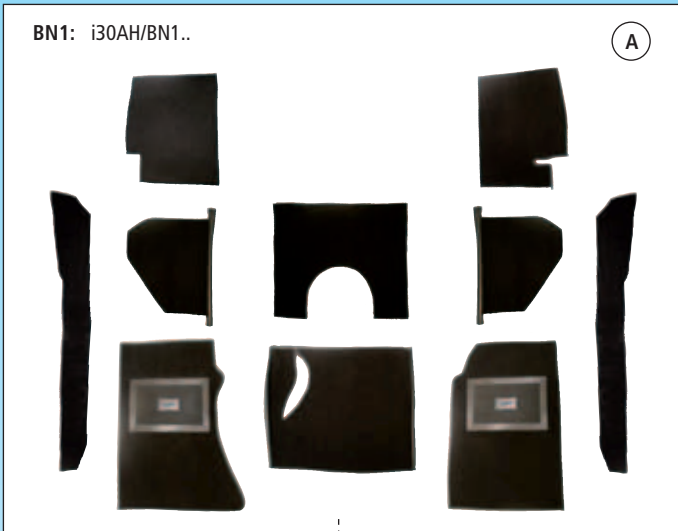

A: Teppichsatz u. Getriebetunnel-Teppich
 B: Bodenbelag "Haduras" unter u. hinter den Sitzen

A: carpet set & carpet gearbox cover
 B: rear cover set "Haduras" below / behind the seats



No.	Bezeichnung	Description	Type	Anzahl/Req.
i30AH/BJ8	Teppichsatz schwarz Mittelschaltung	carpet set black centrechange	BJ8>26705	1
i30AH/BJ8-C	Teppichsatz farbig* Mittelschaltung	carpet set coloured* centrechange	BJ8>26705	1
i30AH/BJ7	Teppichsatz schwarz Mittelschaltung	carpet set black centrechange	BT7>15881, BJ7-BJ8<26704	1
i30AH/BJ7-C	Teppichsatz farbig* Mittelschaltung	carpet set coloured* centrechange	BT7>15881, BJ7-BJ8<26704	1
i30AH/BN4	Teppichsatz schwarz Seitenschaltung	carpet set black side change	BN4+BT7<15880	1
i30AH/BN4-C	Teppichsatz farbig* Seitenschaltung	carpet set coloured* side change	BN4+BT7<15880	1
i30AH/BN7	Teppichsatz schwarz Mittelschaltung	carpet set black centrechange	BN7>16039	1
i30AH/BN7-C	Teppichsatz farbig* Mittelschaltung	carpet set coloured* centrechange	BN7>16039	1
i30AH/BN6	Teppichsatz schwarz Seitenschaltung	carpet set black side change	BN6+BN7<16038	1
i30AH/BN6-C	Teppichsatz farbig* Seitenschaltung	carpet set coloured* side change	BN6+BN7<16038	1
i30AH/BN2	Teppichsatz schwarz Seitenschaltung	carpet set black side change	BN2	1
i30AH/BN2-C	Teppichsatz farbig* Seitenschaltung	carpet set coloured* side change	BN2	1
i30AH/BN1	Teppichsatz schwarz Dreigang-Getriebe	carpet set black 3-speed gearbo	BN1	1
i30AH/BN1-C	Teppichsatz farbig* Dreigang-Getriebe	carpet set coloured* 3-speed gearbox	BN1	1
i31AH/BN1	Bodenbelag hinten schwarz „Haduras“	rear cover set, black „Haduras“	BN1-BN2	1

BJ7 > 15881, BJ7-BJ8 < 26704: i30AH/BJ7..



plus 2 /2 Seat



BJ8 > 26705: i30AH/BJ8..



plus 2 /2 Seat



Schema Teppichsätze /
scheme carpet set:

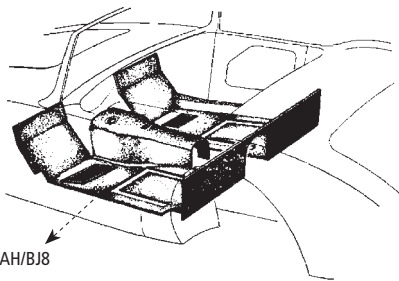

i30AH/BN1-i30AH/BJ8

* farbige Teppichsätze auf Bestellung, in blau oder rot lieferbar.
Beachten Sie bitte die längeren Lieferzeiten (ca. 6-8 Wochen)

– Weitere Hinweise auf der folgenden Seite!

* coloured carpet sets on demand, available in blue or red.
Please note longer time of delivery (ca. 6-8 weeks)

– Please refer to our notes on the next page!



No.	Bezeichnung	Description	Type	Anzahl/Req.
i31AH	Paar Schmutzmatten Velour mit Logo	overmats, pair, velour with logo	BN1-BJ8	1
i103	Druckknopfunterteil	stud, carpet fixing base (on floor panel etc)	BN1-BJ8	ca. 16
i222AH	Bekleidungssatz Reserveradablage schwarz (mit Reserveradhülle)	rear deck kit black (with spare wheel cover)	BN1-BN2	1
i223AH	Bekleidungssatz Reserveradablage schwarz (ohne Reserveradhülle)	rear deck kit black (without spare wheel cover)	BN6-BN7	1
i225AH/BN1	Getriebetunnel GFK	gearbox cover	BN1	1
i225AH/BN2	Getriebetunnel GFK	gearbox cover	BN2	1
i225AH/BJ8	Getriebetunnel Mittelschaltung GFK	gearbox cover centrechange	BN7>16039,BT7>15881,BJ7,BJ8	1
i225AH/BN4	Getriebetunnel für Seitenschaltung GFK	gearbox cover side change	BN4,BN6,BN7<16038,BT7<15880	1
i226AH	Dichtsatz Getriebetunnel	sealing set gearbox cover	BT7>15881,BJ7,BJ8	A/R
i229AH	Dämm-Material, pro qm	insulatio material, per qm	BN1-BJ8	ca. 3 qm
i230AH	Satz (2) Gummifußmatten mit Emblem	pair (2) rubber floor mats with logo	BN1-BJ8	1
i150	Teppich Druckknopf Ober- u. Unterteil	carpet button durable dot and metal socket	BN1-BJ8	ca. 16

Anmerkung:

Teppichbodensatz - für den gesamten Fahrzeuginnenraum (ohne Kofferraum BN1-BJ8 und ohne Reserveradablage BN1/BN2 - siehe hierzu Art.Nr. i222AH bzw. i223AH). Montagefertig, Boden- und Getriebetunnelteppiche mit farblich passendem Vinylleder sauber eingefasst, ohne Befestigungsmaterial. Gefertigt aus original Teppichmaterial - 100% Nylon, mit Gummirücken.

Note:

Complete car carpet set (without boot-lining set BN1-BJ8 and without rear deck trim BN1/BN2, - see no. i222AH resp. i223AH), ready for installation, floor and gearbox carpets bounded with colour matching vinyl, supplied without hardware. Made from original carpet material - 100% nylon, rubber backed.

Weitere Abdeckungs- und Kofferraum Montageteile für 100-4 Modelle auf Seite 189 bzw. für BN4-BJ8 Modelle auf S. 193.

More spare tire cover and track lining kits for 100-4 models on page 189, for BN4-BJ8 models on page 193.



i15AH-BN1
i15AH-BJ.8



i26AH/L



i26AH



EM10AH/BN1



EM140AH



EM104AH



EM107AH



EM106AH



EM10AH/BN4



EM22MGA



EM36AH



EM36AHgrün



EM10AH/BJ8



EM32SPT



EM33SPT



WZ75AH



WZ70AH



WZ80AH

No.	Bezeichnung	Description	Anzahl/Req.
Car Cover - Staubschutzabdeckung		Car Cover - dust protection	
Hochwertige Staubschutzabdeckung mit Austin-Healey Logo, atmungsaktiv, vliesähnlicher Innenstoff für optimalen Lackschutz, mit Stautasche		Top quality dust protection car cover with Austin-Healey logo, breathability, soft lining comparable to fleece, car cover comes with bag	
I15AH-BN1/b	Car Cover Austin Healey 100/4 BN1-BN2 blau mit Logo + Tasche	Car Cover Austin Healey 100/4 BN1-BN2 blue with logo + bag	
I15AH-BN1/g	Car Cover Austin Healey 100/4 BN1-BN2 grün mit Logo + Tasche	Car Cover Austin Healey 100/4 BN1-BN2 green with logo + bag	
I15AH-BJ8/g	Car Cover Austin Healey BN6-BJ8 grün mit Logo + Tasche	Car Cover Austin Healey BN6-BJ8 green with logo + bag	
I15AH-BJ8/b	Car Cover Austin Healey BN6-BJ8 blau mit Logo + Tasche	Car Cover Austin Healey BN6-BJ8 blue with logo + bag	
Pin & Aufnäher		Pin & Sew on batch	
EM104AH	Pin Austin Healey rund rot/schwarz	Pin Austin Healey round red/black	
EM106AH	Pin Austin Healey mit Flügel rot/silber	Pin Austin Healey with wings red/silver	
EM107AH	Pin Union Jack Flagge	Pin Union Jack	
EM140AH	Aufnäher Austin Healey, Ø ca. 7,5 cm	Sew on batch Austin Healey, Ø ca. 7,5 cm	
Schlüsselanhänger, Embleme, Aufkleber		Key fobs, Badges, Decal	
EM10AH/BN1	Aufkleber Satz BN1-BN2	decal set BN1-BN2	1
EM10AH/BN4	Aufkleber Satz BN4, BN6, BN7, BT7	decal set BN4, BN6, BN7, BT7	1
EM10AH/BJ8	Aufkleber Satz BJ7, BJ8	decal set BJ7, BJ8	1
EM32SPT	Union Jack-Fahne emailiert 5 x 2,5 cm (BN1-BJ8)	Union jack enamel badge 5 x 2,5 cm (BN1-BJ8)	1
EM33SPT	Aufkleber Union Jack-Fahne 7,5 x 4,5 cm (BN1-BJ8)	decal Union jack 7,5 x 4,5 cm (BN1-BJ8)	1
EM22MGA-50	Schlüsselanhänger Union-Jack	Key fob Union-Jack	
EM36AH	Schlüsselanhänger Austin Healey rot/schwarz	Key fob Austin Healey red/black	
EM36AHgrün	Schlüsselanhänger Austin Healey silber/grün	Key fob Austin Healey silver/green	
Schaltknöpfe		Gear lever knobs	
i26AH	Holz-Schaltknopf 100/4	Wooden gear lever knob 100/4	
i26AH/L	Lederschaltknopf 100/4	Leather gear lever knob 100/4	
Diverses		Miscellaneous	
WZ70AH	Werkstattschürze mit Austin-Healey logo	Shop apron with Austin-Healey Logo	
WZ75AH	Werkzeugtasche mit Logo (ohne Inhalt)	Tool bag with Logo (w/o content)	
WZ80AH	Kotflügelschoner mit Austin-Healey Logo + Einstelldaten	Wing protector with Austin-Healey Logo + technical data	

Radio Retro Style – modernste Technik im klassischen Design

– auch für den externen Anschluss digitaler Musikquellen

- mit Uhr, Eingang:
- USB,
- SD-Karte
- 2x AUX 3,5 mm Klinke

– modern sound for your classic car with aux input for digital playback possibilities

- radio with clock, connecting inputs:
- USB,
- SD-card
- 2x AUX 3,5 mm

Hinweis: Anschluss nur bei Fahrzeugen mit Minus an Karosserie möglich! / **Note:** Car must be negative ground!



No.	Bezeichnung	Description	Type	Anzahl/Req.
E600chrom	Retro Sound „Classic Style“ Auto Radio Front chrom ohne Blende	Retro Sound „Classic Style“ Auto Radio chrome w/o cover	BN1-BJ8	1
E600schwarz	Retro Sound „Classic Style“ Auto Radio Front schwarz ohne Blende	Retro Sound „Classic Style“ Auto Radio black w/o cover	BN1-BJ8	1
E610chrom	Radio Blende chrom, mit Knöpfen chrom „Classic Style“ für Art. E600..	radio cover chrome, with chrome knobs „Classic Style“ to art. no. E600..	BN1-BJ8	1
E610schwarz	Radio Blende schwarz, mit Knöpfen schwarz „Classic Style“ für Art. E600..	radio cover black, with black knobs, „Classic Style“ to art. no. E600..	BN1-BJ8	1
E610sch/chrom	Radio Blende schwarz mit Chromrand, mit Knöpfen chrom „Classic Style“ für Art. E600..	radio cover black with chrome line, with chrome knobs „Classic Style“ to art. no. E600..	BN1-BJ8	1



Li1AH

Li6AH



CD-AH/BN1-BN6



CD-AH3000



Li20AH



Li21AH



Li22AH

in deutscher Sprache!

Li52AH



Li13D

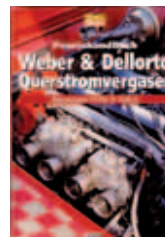

Li14D



Li13MGA-49



Li14MGA-49



Li40AH



Li41AH



Li42AH



Li43AH



Li15MGA



Li81AH



Li82AH

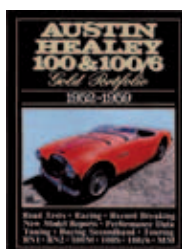

Li85AH

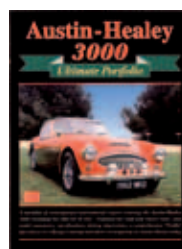

Li86AH / Li87AH

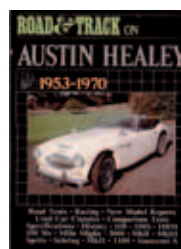

Li88AH

No.	Bezeichnung	Description
Original Ersatzteilkatalog		Original Spare Parts List
Li1AH	Ersatzteilkatalog BN1-BN2, englisch	Spare Parts List BN1-BN2, english
Li6AH	Ersatzteilkatalog BJ7-BJ8, englisch	Spare Parts List BJ7-BJ8, english
Original Werkstatthandbuch		Original Workshop Manual
Li20AH	Werkstatthandbuch BN1-BN2, englisch	Workshop Manual BN1-BN2, english
Li21AH	Werkstatthandbuch BN4-BJ8, englisch	Workshop Manual BN4-BJ8 english
Li22AH	Werkstatthandbuch Austin Healey 3000 BN7,BT7,BJ7 BJ8, deutsch	Workshop Manual Austin Healey 3000 BN7,BT7,BJ7 BJ8, german
Original Bedienungsanleitung		Original Owners Handbook
Li40AH	Bedienungsanleitung BN1-BN2, englisch	Owners handbook BN1-BN2, english
Li41AH	Bedienungsanleitung BN4-BN6, englisch	Owners handbook BN4-BN6, english
Li42AH	Bedienungsanl. BN7-BT7-BJ7, englisch	Owners handbook BN7-BT7-BJ7, english
Li43AH	Bedienungsanleitung BJ8, englisch	Owners handbook BJ8, english
Li52AH	Bedienungsanleitung AH3000 MK2-3 (BJ7,BJ8), deutsch mit englischen Ergänzungen	Owners handbook AH3000 MK2-3 (BJ7,BJ8), german with engl. supplements
Sonstige Literatur		Other Literature
Li82AH	Die Healeys Collectors Guide 100/4 bis MKIII, deutsch	Die Healeys Collectors Guide 100/4 - MKIII models, german
Li81AH	Das Original: Austin Healey, deutsch	Das Original: Austin Healey, german
Li85AH	Austin Healey 100 & 100/6 Gold Portfolio 1952-1959, englisch	Austin Healey 100 & 100/6 Gold Portfolio 1952-1959, english
Li86AH	Austin Healey 3000 Ultimate Portfolio Hard Cover, englisch	Austin Healey 3000 Ultimate Portfolio Hard Cover, english
Li87AH	Austin Healey 3000 Ultimate Portfolio Soft Cover, englisch	Austin Healey 3000 Ultimate Portfolio Soft Cover, english
Li88AH	Road & Track On Austin Healey 1953-1970, englisch	Road & Track On Austin Healey 1953-1970, english
Li13MGA-49	SU Carburettors "Haynes", englisch	SU Carburettors "Haynes", english
Li13D	Su-Vergaser Praxishandbuch, deutsch	SU Carburettors practical guide, german
Li14MGA-49	Weber Carburettors "Haynes", englisch	Weber Carburettors "Haynes", english
Li14D	Weber & Dellorto Querstromvergaser, deutsch	Weber & Dellorto Carburettors, german
Li15MGA	Weber Carburettor Manual "Haynes Techbook", englisch	Weber Carburettor Manual "Haynes Techbook", english
CD-ROM		CD-ROM
CD-AH/BN1-BN6	CD-Rom: Ersatzteilkatalog, Werkstatthandbuch u. Betriebsanleitung Austin Healey BN1-BN6, englisch	CD-Rom: Spare parts catalogue, workshop manual + owners handbook Austin Healey BN1-BN6, english
CD-AH3000	CD-Rom: Ersatzteilkatalog, Werkstatthandbuch u. Betriebsanleitung Austin Healey 3000, englisch	CD-Rom: Spare parts catalogue, workshop manual + owners handbook Austin Healey 3000, english

Steckschlüssel (Nüsse) - 1/2" Antrieb / Socket wrench inserts 1/2" drive

No.	Größe / Dimension	No.	Größe / Dimension
WZ5	7/16"	WZ13	25/32"
WZ6	1/2"	WZ14	13/16"
WZ7	9/16"	WZ15	7/8"
WZ8	19/32"	WZ16	15/16"
WZ9	5/8"	WZ17	31/32"
WZ10	21/32"	WZ18	1"
WZ11	11/16"	WZ18a	1 1/8"
WZ12	3/4"		

Ring-, Gabelschlüssel / Ring & flat wrenches

No.	Größe / Dimension	No.	Größe / Dimension
WZ19	7/16"	WZ24	3/4"
WZ20	1/2"	WZ25	13/16"
WZ21	9/16"	WZ26	7/8"
WZ22	5/8"	WZ27	15/16"
WZ23	11/16"	WZ28	1"

No.	Beschreibung	Description
WZ2	Steckschlüssel-Satz 12-tlg.	Socket wrench 12-pieces
WZ3	Ring/Gabelschlüssel-Satz, 9-tlg. (Schlüssel 3/8" bis 3/4")	Ring- / flat wrench set, 9 pcs. (dimension 3/8" to 3/4")
WZ3/R-14	Ring/Gabelschlüssel-Satz, 14-tlg. in Rolltasche (1/4" bis 3/4")	Ring- / flat wrench set, 14 pcs. in tool bag (dim. 1/4" to 3/4")
WZ4	Inbusschlüssel-Satz	Hexagon wrench set
WZ40	Inbusschlüssel 3/16"	Hexagon wrench set 3/16"
WZ04MGA-53	Zoll-Fühlerlehre (0.0015" - 0.0025")	Feeler gauge (0.0015" - 0.0025")
WZ16MGA-53	Einstellschlüssel SU-Vergaser	Adjusting tool SU-carburettor
WZ19MGA-53	Fettpresse, klein	Grease gum, small
	Hochwertiger Gewinde-schneider Satz 1/8" - 1/2" im Holzkoffer:	Taps & Dies set 1/8" - 1/2" high quality tool in wooden box:
WZ50/UNC	- für Grobgewinde UNC	- for UNC
WZ50/UNF	- für Feingewinde UNF	- for UNF
WZ50/BSF	Gewindebohrer Satz BSF	screw tap set BSF
WZ55	Magnetische Schale	Magnetic tray
WZ101	Einstellschlüssel für Einstell-exzenter Bremse, Schlüsselweite 1/4" + 5/16"	Tool for wheel cylinder adjuster, dimension 1/4" + 5/16"

No.	Beschreibung	Description
MD17SPT	Dauerplast. Universaldichtung „Marston“ 80 ml	Universal jointing compound „Marston“ 80 ml
MD17ASPT	Hochwertige Silikondicht-masse - schwarz „Hylosil“ 200 ml Schrauben Sicherung	Silicone sealant - black „Hylosil“ 200 ml
MD20/HF	„hochfest“ 50 ml Flasche Schrauben Sicherung	„Stud lock“ - 50 ml high strenght
MD20/MF	„mittelfest“ 50 ml Flasche Buchsen-und Lagerbefestigung	„Stud lock“ - 50 ml medium strenght
MD21/HF	50 ml Flasche „hochfest“	„Bush & Bearing lock“ 50 ml high strenght

Wir vertreiben ausschließlich hochwertiges Qualitätswerkzeug von führenden Herstellern (FACOM, HAZET, Stahlwille usw.) mit **lebenslanger Garantie** bei sachgemäßer Handhabung.

We sell only high-quality tools made by the leading manufacturers (FACOM, HAZET, Stahlwille etc...) **with lifetime warranty** if properly used.



RAVENOL®



RV3010-5

RV3010-1



RV3004



RV3002



RV3059



RV3057



RV3025



RV3009

RV3030

RV3031

RV3033

RV3034

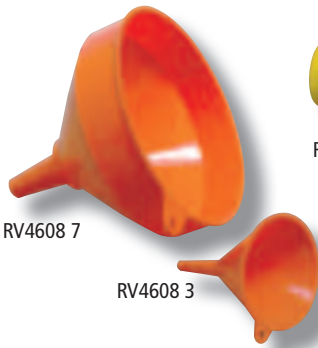

RV4608 7

RV4608 3



RV2004



RV3005



RV4617 0



RV4605 3



IUC *

* Produktverpackung kann abweichen / Picture similar to product

No.	Beschreibung	Description
-----	--------------	-------------

RAVENOL Pumpflaschen / RAVENOL pump aerosol 500 ml

RV3002	Kaltreiniger (lösemittelfrei) zur hochwirksamen Reinigung von Motor- und Maschinenteilen, lackierten und Kunststoffteilen, Fliesen uvm.	Cleaner of all kind of engines, mechanical parts. It quickly penetrates grease, dirt, oil and grime, and swiftly removes contaminants. Product w/o solvent
RV3004	Teerentferner bei Teer- und Ölverschmutzungen auf Chrom und Lack	Cleaner of tar and fats from car lacquers and chrome
RV3025	Glasklar - ideal für alle Glas- und Spiegelflächen innen und außen	Cleaner for all kinds of car glass, mirrors and other hard, glossy surfaces
RV3057	Felgen-Reiniger zur Reinigung von Stahlfelgen, Rahmen, Motorteilen uvm.	Cleaner of steel wheels, car chassis, engine parts ..
RV3059	Insektenentferner auf Glas-, Lack-, Chrom- und Kunststoffflächen	Cleaner of dirt, insects and bird droppings from car lacquer, polish chrome and metall surfaces

RAVENOL Spraydosen / RAVENOL aerosol can 400 ml

RV3009	Rostlöser mit MoS ₂ , bei festgefressenen Schrauben, Quietsch- und Knarrgeräuschen	Effective remedy for rusted and corroded parts and threads, eliminating squeaks, contains MoS ₂
RV3030	Bremsenreiniger für Bremsen- und Kupplungsteile	Brake cleaner for brake and clutch parts
RV3031	Cockpit-Spray zur Reinigung und Pflege von Kunststoff, Kunst- und Naturleder	Cockpit panel cleaner, restores, penetrates and protects all plastic, vinyl and plexiglas surfaces
RV3033	Silikon Spray für die Gummi- und Kunststoffpflege	Silikon spray lubricant. Used for plastics and rubber.
RV3034	Motorstarter für alle Benzin- und Dieselmotoren geeignet	Motor Starter. For petrol and Diesel engines.

Diverses / Divers

RV3005	Autoshampoo - reinigungsintensiv, umweltschonend, 1 Liter	Universal concentrated liquid detergent excellent for thoroughly cleaning cars, 1 litre
RV3010-1	Destilliertes Wasser - entionisiert für Fahrzeugbatterien, Dampfbügeleisen, Aquarien, 1 Liter	Special water for antifreeze, dilution and use in accumulators, 1 litre
RV3010-5	Destilliertes Wasser, 5 Liter	Special water (like above) 5 litres
RV4605 3	Messkanne, 1 Liter	Pot, 1 litre
RV4608 3	Trichter Ø 100 mm	Funnel Ø 100 mm
RV4608 7	Trichter Ø 250 mm	Funnel Ø 250 mm
RV4617 0	Mehrzweckwanne, 7 Liter	Pot, universal, 7 litres
RV2004	Super EP-Langzeitfett, für Gleit- und Wälzlager, 400 gr. Patrone	Super EP Long-life grease for all plain and rolling bearings subjected to heavy loads, cartridge 400 g.
IUC	BASTUCK Inox-Ultra-Clean, Edelstahl- und Chromreiniger, 200 ml	BASTUCK Inox-Ultra-Clean, for stainless steel and chrome parts, 200 ml

Umrechnungstabelle / Conversion Table

Zoll / Inch	1/4"	5/16"	3/8"	7/16"	1/2"	9/16"	5/8"	3/4"	7/8"	1"
Milli- meter	6,35	7,94	9,53	11,12	12,70	14,29	15,88	19,05	22,23	25,40

Zuordnungsübersicht

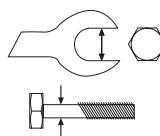

Schlüsselweite (Kopfgröße) / Dimension ▽ = Schaft-Ø / Shaft Ø	7/16"	1/2"	9/16"	5/8"	3/4"
	▽ 1/4"	▽ 5/16"	▽ 3/8"	▽ 7/16"	▽ 1/2"

Schrauben / Bolts BSF (Artikel-Nr = Schaft-Ø x Länge / Part No. = Shaft diameter x length)

Länge / Length:

Schaft-Ø / Shaft diam.:		1/2"	5/8"	3/4"	1"	1 1/4"	1 1/2"
		▽	▽	▽	▽	▽	▽
1/4"	Art.-Nr. / Part No :	S1/4x1/2"BSF	S1/4x5/8"BSF	S1/4x3/4"BSF	S1/4x1"BSF	S1/4x1 1/4"BSF"	S1/4x1 1/2"BSF
5/16"	Art.-Nr. / Part No :			S5/16x3/4"BSF	S5/16x1"BSF	S5/16x1 1/4"BSF	S5/16x1 1/2"BSF
3/8"	Art.-Nr. / Part No :				S3/8x1"BSF	S3/8x1 1/4"BSF	S3/8x1 1/2"BSF
7/16"	Art.-Nr. / Part No :				S7/16x1"BSF	S7/16x1 1/4"BSF	S7/16x1 1/2"BSF
Schaft-Ø / Shaft diam.:		1 3/4"	2"	2 1/4"	2 1/2"	2 3/4"	3"
		▽	▽	▽	▽	▽	▽
1/4"	Art.-Nr. / Part No :	S1/4x1 3/4"BSF	S1/4x2"BSF		S1/4x2 1/2"BSF		S1/4x3"BSF
5/16"	Art.-Nr. / Part No :	S5/16x1 3/4"BSF	S5/16x2"BSF		S5/16x2 1/2"BSF	S5/16x2 3/4"BSF	S5/16x3"BSF
3/8"	Art.-Nr. / Part No :	S3/8x1 3/4"BSF	S3/8x2"BSF		S3/8x2 1/2"BSF	S3/8x2 3/4"BSF	S3/8x3"BSF
7/16"	Art.-Nr. / Part No :	S7/16x1 3/4"BSF	S7/16x2"BSF		S7/16x2 1/2"BSF		
1/2"	Art.-Nr. / Part No :	S1/2x1 3/4"BSF	S1/2x2"BSF	S1/2x2 1/4"BSF	S1/2x2 1/2"BSF		

Viele Schrauben und Muttern für Austin-Healey 100/4 und englische Vorkriegsfahrzeuge ab Lager lieferbar!

Wide range of screws, bolts and nuts for Austin Healey 100/4 and english historical cars (pre-war models) available from stock!

*) Tpi = turns per inch / Mutterumdrehung pro Zoll

Muttern / Nuts BSF (Artikel-Nr = Größe Innen-Ø / Part No. = Dimension of inner diameter)

Sechskantmutter / Standard hex nuts

M2BA

M1/4"BSF

M5/16"BSF

M3/8"BSF

M7/16"BSF

M1/2"BSF

M9/16"BSF



Schlitzmutter / Slotted nuts

M1/4"BSF-G

M5/16"BSF-G

M3/8"BSF-G

M7/16"BSF-G

M1/2"BSF-G

M9/16"BSF-G

VA41MG/TDR (5/8" BSF Rechtsgewinde / RH thread)

VA41MG/TDL (5/8" BSF Linksgewinde / LH thread)



Kronenmutter / Castellated nuts

M3/8"BSF-K

M7/16"BSF-K

M1/4"BSF-K

M1/2"BSF-K



Stopmutter (Nyloc) / Self-locking nuts (nyloc)

M5/16"BSFS

M3/8"BSFS

M1/2"BSFS

M9/16"BSFS



Stopmutter (Metall) / Self-locking nuts (metal)

M1/4"BSFS-M

M5/16"BSFS-M

M7/16"BSFS-M



Hutmutter / Dome nuts

M2BA-H

M1/4"BSF-H

M5/16"BSF-H22 (22 Tpi) *

M5/16"BSF-H26 (26 Tpi) *

M3/8"BSF-H



Messingmutter / Brass nuts

M5BA-BR

M2BA-BR

M1/4"BSF-BR

M5/16"BSF-BR

M3/8"BSF-BR



Schrauben / Bolts UNF / UNC (Artikel-Nr = Schaft-Ø x Länge / Part No. = Shaft diameter x length)

Schaft-Ø / Shaft diam.:	Länge / Length:							
	1/2"	3/4"	1"	1 1/4"	1 1/2"	1 3/4"	2"	2 1/4"
3/16"	Art.-Nr. / Part No : S3/16"x1/2"	S3/16"x3/4"	S3/16"x1"	S3/16"x1 1/4"	S3/16"x1 1/2"			
1/4"	Art.-Nr. / Part No : S1/4"x1/2"	S1/4"x3/4"	S1/4"x1"	S1/4"x1 1/4"	S1/4"x1 1/2"	S1/4"x1 3/4"	S1/4"x2"	
5/16"	Art.-Nr. / Part No : S5/16"x1/2"	S5/16"x3/4"	S5/16"x1"	S5/16"x1 1/4"	S5/16"x1 1/2"	S5/16"x1 3/4"	S5/16"x2"	S5/16"x2 1/4"
3/8"	Art.-Nr. / Part No : S3/8"x1/2"	S3/8"x3/4"	S3/8"x1"	S3/8"x1 1/4"	S3/8"x1 1/2"	S3/8"x1 3/4"	S3/8"x2"	S3/8"x2 1/4"
7/16"	Art.-Nr. / Part No :		S7/16"x1"	S7/16"x1 1/4"	S7/16"x1 1/2"	S7/16"x1 3/4"	S7/16"x2"	S7/16"x2 1/4"
1/2"	Art.-Nr. / Part No :				S1/2"x1 1/2"	S1/2"x1 3/4"	S1/2"x2"	S1/2"x2 1/4"
Schaft-Ø / Shaft diam.:	2 1/2"	2 3/4"	3"	3 1/4"	3 1/2"	4"	4 1/4"	4 1/2"
1/4"	Art.-Nr. / Part No : S1/4"x2 1/2"							
5/16"	Art.-Nr. / Part No : S5/16"x2 1/2"	S5/16"x2 3/4"	S5/16"x3"	S5/16"x3 1/4"	S5/16"x3 1/2"			
3/8"	Art.-Nr. / Part No : S3/8"x2 1/2"	S3/8"x2 3/4"	S3/8"x3"	S3/8"x3 1/4"	S3/8"x3 1/2"			
7/16"	Art.-Nr. / Part No : S7/16"x2 1/2"	S7/16"x2 3/4"	S7/16"x3"	S7/16"x3 1/4"	S7/16"x3 1/2"	S7/16"x4"		
1/2"	Art.-Nr. / Part No : S1/2"x2 1/2"	S1/2"x2 3/4"		S1/2"x3 1/4"		S1/2"x4"		
9/16"	Art.-Nr. / Part No :						S9/16"x4 1/4"	S9/16"x4 1/2"

Muttern und Unterlegscheiben / Nuts & washers UNF / UNC (Artikel-Nr = Größe Innen-Ø / Part No. = Dimension of inner diameter)

Innen-Ø / Inner diameter	Mutter / Nut UNF, UNC	1/2 Mutter / 1/2 nut UNF	Selbstsichernde Mutter / Stop nut UNF	Unterlegscheibe / Washer plain	Zahnscheibe / Washer star	Federring / Washer spring	Karoseriescheibe / Washer reinforcing
3/16"	Art.-Nr. / Part No : M3/16"		M3/16"S	U3/16"	Z3/16"	F3/16"	K3/16"
1/4"	Art.-Nr. / Part No : M1/4"	HM1/4"S	M1/4"S	U1/4"	Z1/4"	F1/4"	K1/4"
5/16"	Art.-Nr. / Part No : M5/16"	HM5/16"S	M5/16"S	U5/16"	Z5/16"	F5/16"	K5/16"
3/8"	Art.-Nr. / Part No : M3/8"	HM3/8"S	M3/8"S	U3/8"	Z3/8"	F3/8"	K3/8"
7/16"	Art.-Nr. / Part No : M7/16"	HM7/16"S	M7/16"S	U7/16"	Z7/16"	F7/16"	
1/2"	Art.-Nr. / Part No : M1/2"	HM1/2"S	M1/2"S	U1/2"	Z1/2"	F1/2"	
9/16"	Art.-Nr. / Part No : M9/16"	HM9/16"S	M9/16"S	U9/16"		F9/16"	
5/8"	Art.-Nr. / Part No : M5/8"	HM5/8"S	M5/8"S	U5/8"		F5/8"	

No.	Bezeichnung	Description
SR1	Sechskant-Blechschaube 6,5 x 20 mm	hexagon palte screw 6,5 x 20 mm
SR2	Blechmutter für SR1 - 6,5 mm	plate nut for SR1
SR3	Rundkopf-Blechschaube 6,3 x 22	binding screw 6,3 x 22
SR4	Rundkopfschraube 1/4"x1"UNF	binding screw 1/4"x1"UNF
SR7	Senkkopfschraube 1/4"x1/2"UNF	countersunk screw 1/4"x1/2"UNF
SR7-3/4"	Senkkopfschraube 1/4"x3/4"UNF	countersunk screw 1/4"x3/4"UNF
SR7-1 3/4"	Senkkopfschraube 1/4"x1 3/4"UNF	countersunk screw 1/4"x1 3/4"UNF
SR7-1"	Senkkopfschraube 1/4"x1"UNF	countersunk screw 1/4"x1"UNF
SR9	Senkkopfschraube 5/16"x1"UNF	countersunk screw 5/16"x1"UNF
SR10	Inbusschraube 1/4"x3/4"UNF	inbus screw 1/4"x3/4"UNF
SR11	Sechskant-Blechschaube 5,5 x 15 mm	hexagon palte screw 5,5 x 15 mm
SR12	Blechmutter 5,5 mm für SR11	plate nut 5,5 mm for SR11
SR13	Senkkopfschraube 3/16"x3/4"	countersunk screw 3/16"x3/4"
SR14	Linsenkopfschraube 3/16"x3/4"	mushroom headed screw 3/16"x3/4"
SR50	Splint 1,5 mm	split pin 1,5 mm
SR51	Splint 2,5 mm	split pin 2,5 mm
SR52	Splint 3,2 mm	split pin 3,2 mm
SR60	Kupferdichtring - 1/4" Innendurchmesser	copper washer - 1/4" inner diameter
SR61	Kupferdichtring - 5/16" Innendurchmesser	copper washer - 5/16" inner diameter
SR62	Kupferdichtring - 3/8" Innendurchmesser	copper washer - 3/8" inner diameter
SR64	Kupferdichtring - 1/2" Innendurchmesser	copper washer - 1/2" inner diameter
S500UNF	Satz UNF Schrauben/Muttern/Scheiben, 500-teilig	ensemble 500 pieces bolts/washers/nuts UNF



Seriennummern

Wichtig bei der Bestellung von Ersatzteilen ist die korrekte Zuordnung Ihres Fahrzeuges durch das Baujahr und die Seriennummer. Da es bei der Produktion zu einigen Änderungen innerhalb einer Baureihe gekommen ist, ermöglichen nur die Angaben über Fahrzeug- (Fahrgestell)nummer, Motornummer und Karosserienummer eine exakte Identifizierung - oft gibt die Modellbezeichnung des Wagens nicht zwangsläufig die korrekte Baureihe an. Soweit es uns möglich war, haben wir bei der Artikelbeschreibung die Fahrgestellnummern aufgelistet. In manchen Fällen wurden aber statt dessen die Motornummer oder Karosserienummer zur Bestimmung herangezogen.

Fig.1: Die Fahrzeugnummer (Fahrgestellnummer) und die Karosserienummer befinden sich eingeschlagen auf einer Platte an der rechten Seite der Spritzwand.

Fig.2: Die Motornummer ist an der vorderen linken Seite des Motorblocks eingeschlagen (nur 100-6 und 3000 Modelle). Bei 100-4 Modellen findet sich diese an der rechten Seite des Blocks.

Fig.3: Die Getriebenummer ist an der rechten Seite am Getriebegehäuse unterhalb des Ölmeßstabes eingeschlagen (außer BN1).

Fig.4: Die Nummer des Overdrive-Getriebes ist auf einer oben am Gehäuse befindlichen Platte eingeschlagen.

Fig.5: Die Nummer der Hinterachse ist an der Achse auf der linken Seite hinten eingeschlagen (BN7-BJ8)

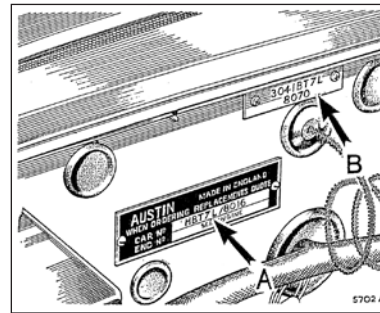

Fig. 1

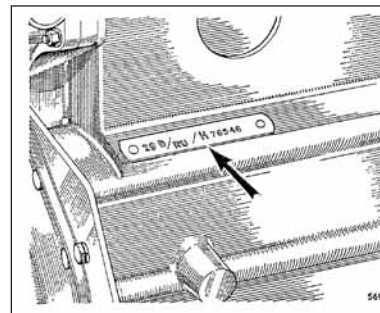

Fig. 2

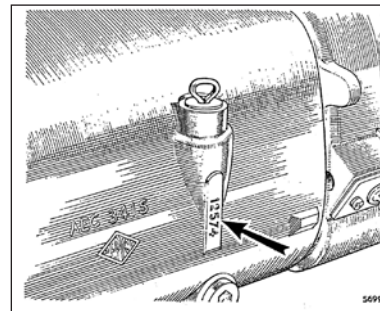

Fig. 3

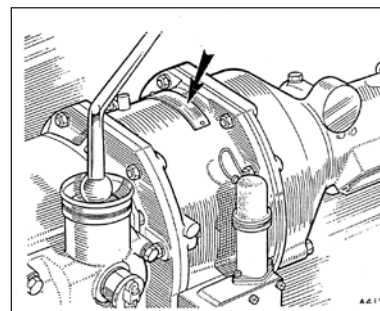

Fig. 4

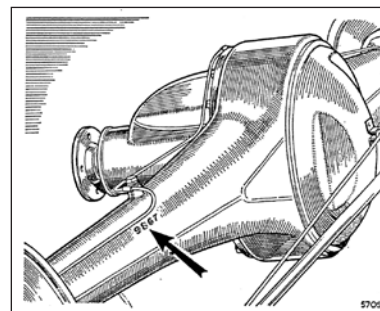

Fig. 5

Identification Numbers

When ordering parts, it is essential that your car is identified exactly, by model year and serial number. Since many part changes were made during model years, the car number, engine number and body number provide the only positive identification. Quite often a car's title will not show the correct model year. Wherever possible, we have listed part applications by car number. In some cases, we had to use the enginenumbers or body numbers.

Fig. 1: The Car Number and the Body Number are stamped on plates on the right-hand side of the firewall.

Fig. 2: The Engine Number is stamped on a plate secured to the front left-hand side of the cylinder block. (100-6 and 3000 only.) The 100-4 is numbered on the right-hand side of the block.

Fig. 3: The Gearbox Number is stamped on the right-hand side of the gearbox below the oil level dipstick (except BN1).

Fig. 4: The Overdrive Number is stamped on a plate secured to the top of the unit.

Fig. 5: The Rear Axle Number is stamped on the rear left-hand side of the axle (BN7-BJ8)

Seriennummer Präfix Code

Die Ziffernreihenfolge der Fahrgestellnummer beinhaltet eine Reihe an Informationen über den Wagen wie Fahrzeugmodell, Motortyp, Karosserietyp, Baureihe und, wenn zutreffend, Linkslenkung

Serial Number Prefix Letter Code

The car number prefix comprises a series of letters and numbers, presenting in code the make, the engine type, the body type, the series and, where applicable, left-hand drive.

1st Prefix Letter - Name H – Healey	2nd Prefix Letter - Motornummer / Engine Type B
3rd Prefix Letter - Karosserietyp / Body Type J – Convertible	
4th Prefix Letter - Baureihe / Series of model 7 – 7th series 8 – 8th series	5th Prefix Letter - (Kennzeichnung nur, wenn von standardmäßiger Rechtslenkung abweichend / used to denote car is different to standard right-hand drive) L – Left-hand drive
<p style="text-align: center;">H - B J 7 - 101</p> <p style="text-align: right;"> Seriennummer / Serial Number 7. Baureihe / 7th Series Roadster / Convertible 2000-2999 ccm Healey </p>	

Identifikations Tabelle / Identification Chart

Baujahr / Year	Modell / Model	Anfangsnummer / Starting Number		Endnummer / Finishing Number		Besonderheiten / Remarks
		Fahrgestell-Nr. / Chassis No.	Motor-Nr. / Engine No.	Fahrgestell-Nr. / Chassis No.	Motor-Nr. / Engine No.	
1953-55	100-4 BN1	133234	136894	228026	unbek. / unknown	3 Gang / 3 speed
1955-56	100-4 BN2	228047	*	*	233455	4 Gang / 4 speed
1956-59	100-6 BN4	22598	**	**	unbek. / unknown	4 Sitzler / 4 seater
1957-59	100-6 BN6	501	60949	4650	26D-H77766	2 Sitzler, 6 port-Zylinderkopf / 2 seater, 6-port cylinder head
1959-61	3000 BN7 MK1	101	29D-H-101	13750	29D-H-26212	2 Sitzler, waagerechte Grillstäbe / 2 seater, horizontal grille slats
1959-61	3000 BT7 MK1	101	29D-H-101	13750	29D-H-26212	4 Sitzler, waagerechte Grillstäbe / 4 seater, horizontal grille slats
1961-62	3000 BN7 MK2	13751	29E-H-101	18888	29E-H-5799	2 Sitzler, vertikale Grillstäbe, 3x 1 1/2" Vergaser / 2 seater, vertical grille slats, 3x 1 1/2" carburetors
1961-62	3000 BT7 MK2	13751	29E-H-101	19853	29E-E5799	4 Sitzler, vertikale Grillstäbe, 3x 1 1/2" Vergaser / 4 seater, vertical grille slats, 3x 1 1/2" carburetors
1962-63	3000 BJ7	17551	29F-101 29FF-101	25314	29F-6188	Kurbelfenster, 2x 1 3/4" Vergaser / roll-up windows, 2x 1 3/4" carburetors
1963-68	3000 BJ8	25315	29F-H-101 29FF-H-101 29KFA-224	43026	29FF-164	Kurbelfenster, 2x 2" Vergaser, Holzarmaturenbrett / roll-up windows, 2x 2" carburetors, wood veneered dash

* bei BN2 wird eine Fahrgestell-/Motornummer benutzt / BN2 uses car/engine numbers

** bei BN2 wird eine Fahrgestell-/Motornummer benutzt / BN2 uses car/engine numbers

Technische Daten / Technical Data

Wichtige Anzugsdrehmomente / Important torque wrench settings

Fahrzeug-Modell / Model	100-4 (BN1, BN2)	100-6 (BN4-BJ6)	3000 (BN7, BT7)	3000 (BJ7, BJ8)
Radmuttern (Stahlfelge) / Road wheel (Steel wheel)	-	8,5 mkg	8,5 mkg	8,5 mkg
Zylinderkopf / Cylinder head	9,61 mkg	10,4 mkg	10,4 mkg	10,4 mkg
Pleuellagerdeckel / Rod bearing	7,6 mkg	6,91 mkg	6,91 mkg	6,91 mkg
Hauptlagerdeckel / Main bearing	10,4 mkg	10,4 mkg	10,4 mkg	10,4 mkg
Schwungrad an Kurbelwelle / Flywheel crankshaft	5,5 mkg	6,91 mkg	6,91 mkg	6,91 mkg

Einstelldaten Motor / Motor data

Fahrzeug-Modell / Model	100-4 (BN1, BN2)	100-6 (BN4-BJ6)	3000 (BN7, BT7)	3000 (BJ7, BJ8)
Unterbrecherabstand / Contact breaker gap	0,40 mm	0,40 mm	0,40 mm	0,40 mm
Zündzeitpunkt / Ignition timing	6 ° v.o.T. / BTDC	6 ° v.o.T. / BTDC	5 ° v.o.T. / BTDC 12 ° v.o.T. / BTDC (MK2)	10 ° v.o.T. / BTDC
Zündfolge / Engine firing order	1-3-4-2	1-5-3-6-2-4	1-5-3-6-2-4	1-5-3-6-2-4
Zündkerze Elektrodenabstand / Spark plug gap	0,6 mm	0,6 mm	0,6 mm	0,6 mm
Leerlaufdrehzahl / Idle speed	600 rpm	500 rpm	500 rpm	500 rpm
Ventilspiel (kalt) / Valve rocker clearance (cold)	0,30 mm	0,30 mm	0,30 mm	0,38 mms

Schmierung & Füllmengen / Lubrication & Capacities

Fahrzeug-Modell / Model	100-4 (BN1, BN2)	100-6 (BN4-BJ6)	3000 (BN7, BT7)	3000 (BJ7, BJ8)	empfohlenes Öl / recommend. oil
Kühlsystem / Cooling system	10,8 l	10,8 l	10,8 l	10,8 l	
Motor / Oil sump	6,7 l	6,7 l	7,25 l	7,25 l	20W50
Getriebe (mit OD) / Gearbox (with OD)	2,98 l	2,98 l	3,27 l	4,2 l	20W50
Hinterachse	1,7 l	1,7 l	1,7 l	1,7 l	Hypoid 80W90